

# **SEMESTER - 1**

COURSE CODE	COURSE NAME	CATEGORY	L	T	P	CREDITS
22MAT101	LINEAR ALGEBRA AND CALCULUS	BS	3	1	0	4

**Preamble:** This course introduces students to some basic mathematical ideas and tools which are at the core of any engineering course. A brief course in Linear Algebra familiarises students with some basic techniques in matrix theory which are essential for analysing linear systems. The calculus of functions of one or more variables taught in this course are useful in modelling and analysing physical phenomena involving continuous change of variables or parameters and have applications across all branches of engineering.

**Prerequisite:** A basic course in one-variable calculus and matrix theory.

**Course Outcomes:** After the completion of the course the student will be able to

<b>CO 1</b>	solve systems of linear equations, diagonalize matrices and characterise quadratic forms
<b>CO 2</b>	compute the partial and total derivatives and maxima and minima of multivariable functions
<b>CO 3</b>	compute multiple integrals and apply them to find areas and volumes of geometrical shapes, mass and centre of gravity of plane laminas
<b>CO 4</b>	perform various tests to determine whether a given series is convergent, absolutely convergent or conditionally convergent
<b>CO 5</b>	determine the Taylor and Fourier series expansion of functions and learn their applications.

**Mapping of course outcomes with program outcomes**

	PO 1	PO 2	PO 3	PO 4	PO 5	PO 6	PO 7	PO 8	PO 9	PO 10	PO 11	PO 12
CO 1	3	3	3	3	2	1			1	2		2
CO 2	3	3	3	3	2	1			1	2		2
CO 3	3	3	3	3	2	1			1	2		2
CO 4	3	2	3	2	1	1			1	2		2
CO 5	3	3	3	3	2	1			1	2		2

**Assessment Pattern**

Bloom's Category	Continuous Assessment Tests		End Semester Examination (Marks)
	Test 1 (Marks)	Test 2 (Marks)	
Remember	10	10	20
Understand	20	20	40
Apply	20	20	40
Analyse			
Evaluate			
Create			

### Mark distribution

Total Marks	CIE marks	ESE marks	ESE Duration
150	50	100	3 hours

### Continuous Internal Evaluation Pattern:

Attendance : 10 marks

Continuous Assessment Test (2 numbers) : 25 marks

Assignment/Quiz/Course project : 15 marks

**Assignments:** Assignment should include specific problems highlighting the applications of the methods introduced in this course in science and engineering.

**End Semester Examination Pattern:** There will be two parts; Part A and Part B. Part A contain 10 questions with 2 questions from each module, having 3 marks for each question. Students should answer all questions. Part B contains 2 questions from each module of which student should answer any one. Each question can have maximum 2 sub-divisions and carry 14 marks.

### Course Level Assessment Questions

**Course Outcome 1 (CO1):** Solve systems of linear equations, diagonalize matrices and characterise quadratic forms

1. A is a real matrix of order  $3 \times 3$  and  $X = \begin{bmatrix} x \\ y \\ z \end{bmatrix}$ . What can you say about the solution of  $AX = 0$  if rank of A is 1? 2? 3?

2. Given  $A = \begin{bmatrix} 3 & 0 & 2 \\ 0 & 2 & 0 \\ -2 & 0 & 0 \end{bmatrix}$ , find an orthogonal matrix  $P$  that diagonalizes A.

3. Find out what type of conic section the following quadratic form represents

$$17x^2 - 30x_1x_2 + 17x_2^2 = 128$$

4. The matrix  $A = \begin{bmatrix} -2 & 2 & -3 \\ 2 & 1 & -6 \\ -1 & -2 & 0 \end{bmatrix}$  has an eigen value 5 with corresponding Eigen vector  $X = \begin{bmatrix} 1 \\ 2 \\ -1 \end{bmatrix}$ . Find  $A^5 X$

**Course Outcome 2 (CO2):** compute the partial and total derivatives and maxima and minima of multivariable functions

1. Find the slope of the surface  $z = x^2y + 5y^3$  in the x-direction at the point (1,-2)

- Given the function  $w = xy + z$ , use chain rule to find the instantaneous rate of change of  $w$  at each point along the curve  $x = \cos t, y = \sin t, z = t$
- Determine the dimension of rectangular box open at the top, having a volume 32 cubic ft and requiring the least amount of material for its construction.

**Course Outcome 3 (CO3):** compute multiple integrals and apply them to find areas and volumes of geometrical shapes, mass and centre of gravity of plane laminas.

- Evaluate  $\iint_D (x + 2y) dA$  where  $D$  is the region bounded by the parabolas  $y = 2x^2$  and  $y = 1 + x^2$
- Explain how you would find the volume under the surface  $z = f(x, y)$  and over a specific region  $D$  in the  $xy$  plane using (i) double integral (ii) triple integral?
- Find the mass and centre of gravity of a triangular lamina with vertices  $(0,0), (2,1), (0,3)$  if the density function is  $f(x, y) = x + y$
- Use spherical coordinates to evaluate  $\iiint_B (x^2 + y^2 + z^2)^3 dV$  where  $B$  is the unit ball defined by  $B = \{(x, y, z): x^2 + y^2 + z^2 \leq 1\}$

**Course Outcome 4 (CO4):** perform various tests to determine whether a given series is convergent, absolutely convergent or conditionally convergent.

- What is the difference between a sequence and a series and when do you say that they are convergent? Divergent?
- Determine whether the series  $\sum_{n=1}^{\infty} \frac{5}{2n^2 + 4n + 3}$  converges or diverges.
- Is the series  $\sum_{n=1}^{\infty} \frac{(-1)^{n-1}}{n}$  convergent? Absolutely convergent? Conditionally convergent?

**Course Outcome 5 (CO5):** determine the Taylor and Fourier series expansion of functions and learn their applications.

- Assuming the possibility of expansion find the Maclaurin series expansion of  $f(x) = (1 + x)^k$  for  $|x| < 1$  where  $k$  is any real number. What happens if  $k$  is a positive integer?
- Use Maclaurin series of  $\ln(1 + x), -1 < x \leq 1$  to find an approximate value of  $\ln 2$ .
- Find the Fourier series of the function  $f(x) = x^2, -2 \leq x < 2, f(x + 4) = f(x)$ . Hence using Parseval's identity prove that  $1 + \frac{1}{2^4} + \frac{1}{3^4} + \dots = \frac{\pi^4}{90}$
- Expand the function  $f(x) = x$  ( $0 < x < 1/2$ ) into a (i) Fourier sine series (ii) Fourier cosine series.



Model Question paper

QP CODE:

PAGES:3

Reg No: \_\_\_\_\_

Name : \_\_\_\_\_

APJ ABDUL KALAM TECHNOLOGICAL UNIVERSITY FIRST SEMESTER B.TECH DEGREE EXAMINATION,  
MONTH & YEAR

Course Code: MAT 101

Max. Marks: 100

Duration: 3 Hours

LINEAR ALGEBRA AND CALCULUS

(2019-Scheme)

(Common to all branches)

PART A

(Answer all questions, each question carries 3 marks)

1. Determine the rank of the matrix  $A = \begin{bmatrix} 1 & 2 & -1 \\ -2 & -4 & 2 \\ 3 & 6 & -3 \end{bmatrix}$ .
2. Write down the eigen values of  $A = \begin{bmatrix} 2 & 0 \\ 0 & -1 \end{bmatrix}$ . What are the eigen values of  $P^{-1}AP$  where  $P = \begin{bmatrix} -4 & 2 \\ 3 & -1 \end{bmatrix}$ ?
3. Find  $f_x(1,3)$  and  $f_y(1,3)$  for the function  $f(x,y) = 2x^3y^2 + 2y + 4x$ .
4. Show that the function  $u(x,t) = \sin(x - ct)$  is a solution of the equation  $\frac{\partial^2 u}{\partial t^2} = c^2 \frac{\partial^2 u}{\partial x^2}$ .
5. Use double integral to find the area of the region enclosed between the parabolas  $y = \frac{1}{2}x^2$  and the line  $y = 2x$ .
6. Use polar coordinates to evaluate the area of the region bounded by  $x^2 + y^2 = 4$ , the line  $y = x$  and the y axis in the first quadrant
7. Test the convergence of the series  $\sum_{k=1}^{\infty} \frac{k}{k+1}$ .
8. Test the convergence of the alternating series  $\sum_{k=1}^{\infty} (-1)^{k+1} \frac{1}{k}$  using Leibnitz test.
9. Find the Taylor series expansion of  $\sin \pi x$  about  $x = \frac{1}{2}$ .
10. Find the values to which the Fourier series of

$f(x) = x$  for  $-\pi < x < \pi$ , with  $f(x + 2\pi) = f(x)$  converges (10x3=30)

**PART B**

(Answer **one full** question from each module, each question carries **14** marks)

**Module - I**

11. (a) Solve the following system of equations

$$\begin{aligned}y + z - 2w &= 0 \\2x - 3y - 3z + 6w &= 2 \\4x + y + z - 2w &= 4\end{aligned}$$

- (b) Find the eigen values and eigen vectors of the matrix  $\begin{bmatrix} -2 & 2 & -3 \\ 2 & 1 & -6 \\ -1 & -2 & 0 \end{bmatrix}$

12. (a) Diagonalize the matrix  $\begin{bmatrix} -1 & 2 & -2 \\ 2 & 4 & 1 \\ 2 & 1 & 4 \end{bmatrix}$

- (b) What kind of conic section the quadratic form  $3x_1^2 + 22x_1x_2 + 3x_2^2 = 0$  represents? Transform it to principal axes.

**Module - II**

13. (a) Find the local linear approximation to  $f(x, y) = \sqrt{x^2 + y^2}$  at the point (3, 4). Use it to approximate  $f(3.04, 3.98)$

- (b) Let  $w = \sqrt{x^2 + y^2 + z^2}$ ,  $x = \cos\theta$ ,  $y = \sin\theta$ ,  $z = \tan\theta$ . Use chain rule to find  $\frac{dw}{d\theta}$  when  $\theta = \frac{\pi}{4}$ .

14. (a) Let  $z = f(x, y)$  where  $x = r\cos\theta$ ,  $y = r\sin\theta$ , prove that

$$\left(\frac{\partial z}{\partial x}\right)^2 + \left(\frac{\partial z}{\partial y}\right)^2 = \left(\frac{\partial z}{\partial r}\right)^2 + \frac{1}{r^2}\left(\frac{\partial z}{\partial \theta}\right)^2.$$

- (b) Locate all relative maxima, relative minima and saddle points

$$f(x, y) = xy + \frac{a^3}{x} + \frac{b^3}{y} \quad (a \neq 0, b \neq 0).$$

**Module - III**

15. (a) Evaluate  $\iint_D (2x^2y + 9y^3) dx dy$  where D is the region bounded by  $y = \frac{2}{3}x$  and  $y = 2\sqrt{x}$

- (b) Evaluate  $\int_0^4 \int_{\sqrt{y}}^2 e^{x^3} dx dy$  changing the order of integration.

16. (a) Find the volume of the solid bounded by the cylinder  $x^2 + y^2 = 4$  and the planes  $y + z = 4$  and  $z = 0$ .

- (b) Evaluate  $\iiint \sqrt{1 - x^2 - y^2 - z^2} dx dy dz$ , taken throughout the volume of the sphere  $x^2 + y^2 + z^2 = 1$ , by transforming to spherical polar coordinates

**Module - IV**

17. (a) Test the convergence of the series

$$(i) \quad \sum_{k=1}^{\infty} \frac{k^k}{k!} \quad (ii) \quad \sum_{k=2}^{\infty} \left(\frac{4k-5}{2k+1}\right)^k$$

- (b) Determine the convergence or divergence of the series  $\sum_{k=1}^{\infty} (-1)^k \frac{(2k-1)!}{3^k}$

18. (a) Check whether the series  $\sum_{k=1}^{\infty} (-1)^{k+1} \frac{(2k)!}{(3k-2)!}$  is absolutely convergent, conditionally convergent or divergent.

(b) Test the convergence of the series  $1 + \frac{1.2}{1.3} + \frac{1.2.3}{1.3.5} + \frac{1.2.3.4}{1.3.5.7} + \dots$

### Module - V

19. (a) Obtain the Fourier series of for  $f(x) = e^{-x}$ , in the interval  $0 < x < 2\pi$ . with  $f(x + 2\pi) = f(x)$ . Hence deduce the value of  $\sum_{n=2}^{\infty} \frac{(-1)^n}{1+n^2}$ .

(b) Find the half range sine series of  $f(x) = \begin{cases} \frac{2kL}{x} & \text{if } 0 < x < \frac{L}{2} \\ \frac{2k(L-x)}{L} & \text{if } \frac{L}{2} < x < L \end{cases}$

20. (a) Expand  $(1+x)^{-2}$ . as a Taylor series about  $x = 0$  and state the region of convergence of the series.

(b) Find the Fourier series for  $f(x) = x^2$  in the interval  $-\pi < x < \pi$

with  $f(x + 2\pi) = f(x)$ . Hence show that  $\frac{1}{1^4} + \frac{1}{2^4} + \frac{1}{3^4} + \dots = \frac{\pi^4}{90}$ . (14X5=70)

### Syllabus

#### Module 1 (Linear algebra)

(Text 2: Relevant topics from sections 7.3, 7.4, 7.5, 8.1, 8.3, 8.4)

Systems of linear equations, Solution by Gauss elimination, row echelon form and rank of a matrix, fundamental theorem for linear systems (homogeneous and non-homogeneous, without proof), Eigen values and eigen vectors. Diagonalization of matrices, orthogonal transformation, quadratic forms and their canonical forms.

#### Module 2 (multivariable calculus-Differentiation)

(Text 1: Relevant topics from sections 13.3, 13.4, 13.5, 13.8)

Concept of limit and continuity of functions of two variables, partial derivatives, Differentials, Local Linear approximations, chain rule, total derivative, Relative maxima and minima, Absolute maxima and minima on closed and bounded set.

#### Module 3 (multivariable calculus-Integration)

(Text 1: Relevant topics from sections 14.1, 14.2, 14.3, 14.5, 14.6, 14.8)

Double integrals (Cartesian), reversing the order of integration, Change of coordinates (Cartesian to polar), finding areas and volume using double integrals, mass and centre of gravity of inhomogeneous laminas using double integral. Triple integrals, volume calculated as triple integral, triple integral in cylindrical and spherical coordinates (computations involving spheres, cylinders).

#### Module 4 (sequences and series)

(Text 1: Relevant topics from sections 9.1, 9.3, 9.4, 9.5, 9.6)

Convergence of sequences and series, convergence of geometric series and p-series(without proof), test of convergence (comparison, ratio and root tests without proof); Alternating series and Leibnitz test, absolute and conditional convergence.

#### Module 5 (Series representation of functions)

(Text 1: Relevant topics from sections 9.8, 9.9. Text 2: Relevant topics from sections 11.1, 11.2, 11.6 )

Taylor series (without proof, assuming the possibility of power series expansion in appropriate domains), Binomial series and series representation of exponential, trigonometric, logarithmic functions (without proofs of convergence); Fourier series, Euler formulas, Convergence of Fourier series (without proof), half range sine and cosine series, Parseval's theorem (without proof).

#### Text Books

1. H. Anton, I. Biven, S. Davis, "Calculus", Wiley, 10<sup>th</sup> edition, 2015.
2. Erwin Kreyszig, Advanced Engineering Mathematics, 10<sup>th</sup> Edition, John Wiley & Sons, 2016.

#### Reference Books

1. J. Stewart, Essential Calculus, Cengage, 2<sup>nd</sup> edition, 2017
2. G.B. Thomas and R.L. Finney, Calculus and Analytic geometry, 9<sup>th</sup> Edition, Pearson, Reprint, 2002.
3. Peter V. O'Neil, Advanced Engineering Mathematics, Cengage, 7<sup>th</sup> Edition, 2012
4. Veerarajan T., Engineering Mathematics for first year, Tata McGraw-Hill, New Delhi, 2008.
5. B.S. Grewal, Higher Engineering Mathematics, Khanna Publishers, 36<sup>th</sup> Edition, 2010.

#### Course Contents and Lecture Schedule

No	Topic	No. of Lectures
<b>1</b>	<b>Linear Algebra (10 hours)</b>	
1.1	Systems of linear equations, Solution by Gauss elimination	1
1.2	Row echelon form, finding rank from row echelon form, fundamental theorem for linear systems	3
1.3	Eigen values and eigen vectors	2
1.4	Diagonalization of matrices, orthogonal transformation, quadratic forms	4

	and their canonical forms.	
<b>2</b>	<b>Multivariable calculus-Differentiation (8 hours)</b>	
2.1	Concept of limit and continuity of functions of two variables, partial derivatives	2
2.2	Differentials, Local Linear approximations	2
2.3	Chain rule, total derivative	2
2.4	Maxima and minima	2
<b>3</b>	<b>Multivariable calculus-Integration (10 hours)</b>	
3.1	Double integrals (Cartesian)-evaluation	2
3.2	Change of order of integration in double integrals, change of coordinates (Cartesian to polar),	2
3.3	Finding areas and volumes, mass and centre of gravity of plane laminas	3
3.4	Triple integrals	3
<b>4</b>	<b>Sequences and series (8 hours)</b>	
4.1	Convergence of sequences and series, geometric and p-series	2
4.2	Test of convergence( comparison, ratio and root )	4
4.3	Alternating series and Leibnitz test, absolute and conditional convergence	2
<b>5</b>	<b>Series representation of functions (9 hours)</b>	
5.1	Taylor series, Binomial series and series representation of exponential, trigonometric, logarithmic functions;	3
5.2	Fourier series, Euler formulas, Convergence of Fourier series(Dirichlet's conditions)	3
5.3	Half range sine and cosine series, Parseval's theorem.	3

COURSE CODE	COURSE NAME	CATEGORY	L	T	P	CREDITS
22PHT102	ENGINEERING PHYSICS B	BS	3	1	0	4

**Preamble:** The aim of the Engineering Physics program is to offer students a solid background in the fundamentals of Physics and to impart that knowledge in engineering disciplines. The program is designed to develop scientific attitudes and enable the students to correlate the concepts of Physics with the core programmes

**Prerequisite:** Higher secondary level Physics, Mathematical course on vector calculus, differential equations and linear algebra

**Course Outcomes:** After the completion of the course the student will be able to

CO 1	Compute the quantitative aspects of waves and oscillations in engineering systems.
CO 2	Apply the interaction of light with matter through interference, diffraction and identify these phenomena in different natural optical processes and optical instruments.
CO 3	Analyze the behaviour of matter in the atomic and subatomic level through the principles of quantum mechanics to perceive the microscopic processes in electronic devices.
CO 4	Apply the knowledge of ultrasonics in non-destructive testing and use the principles of acoustics to explain the nature and characterization of acoustic design and to provide a safe and healthy environment
CO 5	Apply the comprehended knowledge about laser and fibre optic communication systems in various engineering applications

#### Mapping of course outcomes with program outcomes

	PO 1	PO 2	PO 3	PO 4	PO 5	PO 6	PO 7	PO 8	PO 9	PO 10	PO 11	PO 12
CO 1	3	2						1	2			1
CO 2	3	2						1	2			1
CO 3	3	2						1	2			1
CO 4	3							1	2			1
CO 5	3	2						1	2			1

#### Assessment Pattern

Bloom's Category	Continuous Assessment Tests		End Semester Examination (Marks)
	Test 1 (Marks)	Test 2 (Marks)	
Remember	15	15	30
Understand	25	25	50

Apply	10	10	20
Analyse			
Evaluate			
Create			

### Mark distribution

Total Marks	CIE MARKS	ESE MARKS	ESE Duration
150	50	100	3 hours

### Continuous Internal Evaluation Pattern:

Attendance	: 10 marks
Continuous Assessment Test (2 numbers)	: 25 marks
Assignment/Quiz/Course project	: 15 marks

**End Semester Examination Pattern:** There will be two parts; Part A and Part B. Part A contain 10 questions with 2 questions from each module, having 3 marks for each question. Students should answer all questions. Part B contains 2 questions from each module of which student should answer any one. Each question can have maximum 2 sub-divisions and carry 14 marks.

### Course Level Assessment Questions

#### Course Outcome 1 (CO1):

1. Explain the effect of damping force on oscillators.
2. Distinguish between transverse and longitudinal waves.
3. (a) Derive an expression for the fundamental frequency of transverse vibration in a stretched string.  
(b) Calculate the fundamental frequency of a string of length 2 m weighing 6 g kept stretched by a load of 600 kg.

#### Course Outcome 2 (CO2):

1. Explain colours in thin films.
2. Distinguish between Fresnel and Fraunhofer diffraction.
3. (a) Explain the formation of Newton's rings and obtain the expression for radii of bright and dark rings in reflected system. Also explain how it is used to determine the wavelength of a monochromatic source of light.  
(b) A liquid of refractive index  $\mu$  is introduced between the lens and glass plate. What happens to the fringe system? Justify your answer.

#### Course Outcome 3 (CO3):

1. Give the physical significance of wave function?

2. What are excitons ?
3. (a) Solve Schrodinger equation for a particle in a one dimensional box and obtain its energy eigen values and normalised wave functions.  
(b) Calculate the first three energy values of an electron in a one dimensional box of width  $1 \text{ \AA}$  in electron volt.

**Course Outcome 4 (CO4):**

1. Explain reverberation and reverberation time.
2. How ultrasonic waves are used in non-destructive testing.
3. (a) With a neat diagram explain how ultrasonic waves are produced by a piezoelectric oscillator.  
(b) Calculate frequency of ultrasonic waves that can be produced by a nickel rod of length 4 cm. (Young's Modulus = 207 G Pa, Density =  $8900 \text{ Kg /m}^3$ )

**Course Outcome 5 (CO 5):**

1. Distinguish between spontaneous emission and stimulated emission.
2. Explain optical resonators.
3. (a) Explain the construction and working of Ruby Laser.  
(b) Calculate the numerical aperture and acceptance angle of a fibre with a core refractive index of 1.54 and a cladding refractive index of 1.50 when the fibre is inside water of refractive index 1.33.



**Model Question paper**

QP CODE:

PAGES:3

Reg No: \_\_\_\_\_

Name : \_\_\_\_\_

**APJ ABDUL KALAM TECHNOLOGICAL UNIVERSITY FIRST SEMESTER B.TECH DEGREE EXAMINATION,  
MONTH & YEAR**

**Course Code: PHT 110**

**Course Name: Engineering Physics B**

**Max.Marks: 100**

**Duration: 3 Hours**

**PART A**

**Answer all Questions. Each question carries 3 Marks**

1. Compare electrical and mechanical oscillators.
2. Distinguish between longitudinal and transverse waves.
3. Write a short note on antireflection coating.
4. Diffraction of light is not as evident in daily experience as that of sound waves. Give reason.
5. State and explain Heisenberg's Uncertainty principle. With the help of it explain natural line broadening.
6. Explain surface to volume ratio of nanomaterials.
7. Define sound intensity level. Give the values of threshold of hearing and threshold of pain.
8. Describe the method of non-destructive testing using ultra sonic waves
9. Explain the condition of population inversion
10. Distinguish between step index and graded index fibre. (10x3=30)

**PART B**

**Answer any one full question from each module. Each question carries 14 Marks**

**Module 1**

11. (a) Derive the differential equation of damped harmonic oscillator and deduce its solution. Discuss the cases of over damped, critically damped and under damped cases. (10)

(b) The frequency of a tuning fork is 500 Hz and its Q factor is  $7 \times 10^4$ . Find the relaxation time. Also calculate the time after which its energy becomes 1/10 of its initial undamped value. (4)

12. (a) Derive an expression for the velocity of propagation of a transverse wave in a stretched string. Deduce laws of transverse vibrations. (10)

(b) The equation of transverse vibration of a stretched string is given by  $y = 0.00327 \sin(72.1x - 2.72t)$  m, in which the numerical constants are in S.I. units. Evaluate (i) Amplitude (ii) Wavelength (iii) Frequency and (iv) Velocity of the wave. (4)

### Module 2

13. (a) Explain the formation of Newton's rings and show that the radius of dark ring is proportional to the square root of natural numbers. How can we use Newton's rings experiment to determine the refractive index of a liquid? (10)

(b) Two pieces of plane glass are placed together with a piece of paper between two at one end. Find the angle of the wedge in seconds if the film is viewed with a monochromatic light of wavelength  $4800 \text{ \AA}$ . Given  $\beta = 0.0555 \text{ cm}$ . (4)

14. (a) Explain the diffraction due to a plane transmission grating. Obtain the grating equation. (10)

(b) A grating has 6000 lines per cm. Find the angular separation of the two yellow lines of mercury of wavelengths 577 nm and 579 nm in the second order. (4)

### Module 3

15. (a) Derive time dependent and independent Schrodinger equations. (10)

(b) An electron is confined to one dimensional potential box of length  $2 \text{ \AA}$ . Calculate the energies corresponding to the first and second quantum states in eV. (4)

16. (a) Classify nanomaterials based on dimensionality of quantum confinement and explain the following nanostructures. (i) nano sheets (ii) nano wires (iii) quantum dots. (10)

(b) Find the de Broglie wavelength of electron whose kinetic energy is 15 eV. (4)

### Module 4

17. (a) Explain reverberation and reverberation time? What is the significance of Reverberation time. Explain the factors affecting the acoustics of a building and their corrective measures? (10)

(b) The volume of a hall is  $3000 \text{ m}^3$ . It has a total absorption of  $100 \text{ m}^2$  sabine. If the hall is filled with audience who add another  $80 \text{ m}^2$  sabine, then find the difference in reverberation time. (4)

18. (a) With a neat diagram explain how ultrasonic waves are produced by piezoelectric oscillator. Also discuss the piezoelectric method of detection of ultrasonic waves. (10)

- (b) An ultrasonic source of 0.09 MHz sends down a pulse towards the sea bed which returns after 0.55 sec. The velocity of sound in sea water is 1800 m/s. Calculate the depth of the sea and the wavelength of the pulse. (4)

**Module 5**

19. (a) Outline the construction and working of Ruby laser. (8)
- (b) What is the principle of holography? How is a hologram recorded? (6)
20. (a) Define numerical aperture of an optic fibre and derive an expression for the NA of a step index fibre with a neat diagram. (10)
- (b) An optical fibre made with core of refractive index 1.5 and cladding with a fractional index difference of 0.0006. Find refractive index of cladding and numerical aperture. (4)

(14x5=70)

## SYLLABUS

### ENGINEERING PHYSICS B (FOR NON-CIRCUIT BRANCHES)

#### Module 1

##### Oscillations and Waves

Harmonic oscillations, Damped harmonic motion-Derivation of differential equation and its solution, Over damped, Critically damped and Under damped Cases, Quality factor-Expression, Forced oscillations-Differential Equation-Derivation of expressions for amplitude and phase of forced oscillations, Amplitude Resonance-Expression for Resonant frequency, Quality factor and Sharpness of Resonance, Electrical analogy of mechanical oscillators

Wave motion- Derivation of one dimensional wave equation and its solution, Three dimensional wave equation and its solution (no derivation), Distinction between transverse and longitudinal waves, Transverse vibration in a stretched string, Statement of laws of vibration

#### Module 2

##### Wave Optics

Interference of light-Principle of superposition of waves, Theory of thin films - Cosine law (Reflected system), Derivation of the conditions of constructive and destructive Interference, Interference due to wedge shaped films -Determination of thickness and test for optical planeness, Newton's rings - Measurement of wavelength and refractive index, Antireflection coatings

Diffraction of light, Fresnel and Fraunhofer classes of diffraction, Diffraction grating-Grating equation, Rayleigh criterion for limit of resolution, Resolving and Dispersive power of a grating with expression (no derivation)

#### Module 3

##### Quantum Mechanics & Nanotechnology

Introduction for the need of Quantum mechanics, Wave nature of Particles, Uncertainty principle, Applications-Absence of electrons inside a nucleus and Natural line broadening Mechanism, Formulation of time dependent and independent Schrodinger wave equations-Physical Meaning of wave function, Particle in a one dimensional box- Derivation for normalised wave function and energy eigen values, Quantum Mechanical Tunnelling (Qualitative)

Introduction to nanoscience and technology, Increase in surface to volume ratio for nanomaterials, Quantum confinement in one dimension, two dimension and three dimension-Nano sheets, Nano wires and Quantum dots, Properties of nanomaterials-mechanical, electrical and optical, Applications of nanotechnology (qualitative ideas)

#### Module 4

##### Acoustics & Ultrasonics

Acoustics, Classification of sound-Musical sound-Noise, Characteristics of Musical Sounds-Pitch or frequency-Loudness or Intensity-Measurement of Intensity level-Decibel-Quality or timbre, Absorption coefficient, Reverberation-Reverberation time-Significance- Sabine's formula (no derivation), Factors affecting architectural acoustics and their remedies

Ultrasonics-Production- Magnetostriction effect and Piezoelectric effect, Magnetostriction oscillator and Piezoelectric oscillator –Working, Detection of ultrasonic waves - Thermal and Piezoelectric

methods, Ultrasonic diffractometer- Expression for the velocity of ultrasonic waves in a liquid , Applications of ultrasonic waves -SONAR,NDT and Medical

## **Module 5**

### **Laser and Fibre optics**

Properties of laser, Absorption and emission of radiation, Spontaneous and stimulated emission, Einstein's coefficients (no derivation), Population inversion, Metastable states, basic components of laser, Active medium, Pumping mechanism, Optical resonant cavity, working principle, Construction and working of Ruby laser and Helium neon laser ,Construction and working of semiconductor laser(Qualitative) ,Applications of laser, Holography, Difference between hologram and photograph, Recording of hologram and reconstruction of image, Applications

Optic fibre-Principle of propagation of light, Types of fibres-Step index and Graded index fibres, Numerical aperture –Derivation, Fibre optic communication system (block diagram), Industrial, Medical and Technological applications, Fibre optic sensors-Intensity Modulated and Phase modulated sensors

### **Text Books**

1. M.N.Avadhanulu, P.G.Kshirsagar,TVS Arun Murthy "A Text book of Engineering Physics", S.Chand &Co., Revised Edition, 2019.
2. H.K.Malik , A.K. Singh, "Engineering Physics" McGraw Hill Education, Second Edition, 2017.

### **Reference Books**

1. Arthur Beiser, "Concepts of Modern Physics ", Tata McGraw Hill Publications, 6th Edition 2003
2. D.K. Bhattacharya, Poonam Tandon, "Engineering Physics", Oxford University Press, 2015
3. Md.N.Khan & S.Panigrahi "Principles of Engineering Physics 1&2", Cambridge University Press, 2016
4. Aruldhas G., "Engineering Physics", PHI Pvt. Ltd., 2015
5. Ajoy Ghatak, "Optics", Mc Graw Hill Education, Sixth Edition, 2017
6. T. Pradeep, "Nano:The Essentials", McGraw Hill India Ltd, 2007
7. B. B. Laud, "Lasers and Non linear optics", New age International Publishers, 2nd Edition ,2005
8. Premlet B., "Advanced Engineering Physics", Phasor Books,10<sup>th</sup> edition ,2017
9. I. Dominic and. A. Nahari, "A Text Book of Engineering physics", Owl Books Publishers, Revised edition, 2016

### Course Contents and Lecture Schedule

No	Topic	No. of Lectures
1	<b>Oscillations and Waves ( 9 hours)</b>	
1.1	Harmonic oscillations, Damped harmonic motion-Derivation of differential equation and its solution, Over damped, Critically damped and Under damped Cases, Quality factor-Expression	2 hrs
1.2	Forced oscillations-Differential Equation-Derivation of expressions for amplitude and phase of forced oscillations, Amplitude Resonance-Expression for Resonant frequency, Quality factor and Sharpness of Resonance, Electrical analogy of mechanical oscillators	3hrs
1.3	Wave motion- Derivation of one dimensional wave equation and its solution, Three dimensional wave equation and its solution (no derivation)	2 hrs
1.4	Distinction between transverse and longitudinal waves, Transverse vibration in a stretched string, Statement of laws of vibration	2 hrs
2	<b>Wave Optics (9 hours)</b>	
2.1	Interference of light-Principle of superposition of waves, Theory of thin films - Cosine law (Reflected system), Derivation of the conditions of constructive and destructive Interference	2 hrs
2.2	Interference due to wedge shaped films -Determination of thickness and test for optical planeness, Newton's rings - Measurement of wavelength and refractive index, Antireflection coatings	4 hrs
2.3	Diffraction of light, Fresnel and Fraunhofer classes of diffraction, Diffraction grating-Grating equation	2 hrs
2.4	Rayleigh criterion for limit of resolution, Resolving and Dispersive power of a grating with expression (no derivation)	1 hr
3	<b>Quantum Mechanics &amp; Nanotechnology (9hours)</b>	
3.1	Introduction for the need of Quantum mechanics, Wave nature of Particles, Uncertainty principle, Applications-Absence of electrons inside a nucleus and Natural line broadening mechanism	2 hrs
3.2	Formulation of time dependent and independent Schrodinger wave equations-Physical Meaning of wave function, Particle in a one dimensional box- Derivation for normalised wave function and energy eigen values, Quantum Mechanical Tunnelling (Qualitative)	4 hrs
3.3	Introduction to nanoscience and technology, Increase in surface to volume ratio for nanomaterials, Quantum confinement in one dimension, two dimension and three dimension-Nano sheets, Nano wires and Quantum dots	2 hrs
3.4	Properties of nanomaterials-mechanical, electrical and optical Applications of nanotechnology (qualitative ideas)	1 hr
4	<b>Acoustics &amp; Ultrasonics (9hrs)</b>	
4.1	Acoustics, Classification of sound-Musical sound-Noise, Characteristics	3 hrs

	of Musical Sounds-Pitch or frequency-Loudness or Intensity-Measurement of Intensity level-Decibel-Quality or timbre, Absorption coefficient, Reverberation-Reverberation time-Significance- Sabine's formula (no derivation)	
4.2	Factors affecting architectural acoustics and their remedies	1 hr
4.3	Ultrasonics-Production- Magnetostriction effect and Piezoelectric effect, Magnetostriction oscillator and Piezoelectric oscillator – Working, Detection of ultrasonic waves - Thermal and Piezoelectric methods	3hrs
4.4	Ultrasonic diffractometer- Expression for the velocity of ultrasonic waves in a liquid ,Applications of ultrasonic waves -SONAR,NDT and Medical.	2 hr
5	<b>Laser and Fibre optics ( 9hours)</b>	
5.1	Properties of laser, Absorption and emission of radiation, Spontaneous and stimulated emission, Einstein's coefficients (no derivation), Population inversion, Metastable states, basic components of laser, Active medium, Pumping mechanism, Optical resonant cavity, working principle	2 hrs
5.2	Construction and working of Ruby laser and Helium neon laser ,Construction and working of semiconductor laser(Qualitative) Applications of laser	3 hrs
5.3	Holography, Difference between hologram and photograph, Recording of hologram and reconstruction of image, Applications	1 hr
5.4	Optic fibre-Principle of propagation of light, Types of fibres-Step index and Graded index fibres, Numerical aperture –Derivation, Fibre optic communication system (block diagram), Industrial, Medical and Technological applications, Fibre optic sensors-Intensity Modulated and Phase modulated sensors	3 hrs

COURSE CODE	COURSE NAME	CATEGORY	L	T	P	CREDITS
22CYT103	ENGINEERING CHEMISTRY	BS	3	1	0	4

**Preamble:** To enable the students to acquire knowledge in the concepts of chemistry for engineering applications and to familiarize the students with different application oriented topics like spectroscopy, electrochemistry, instrumental methods etc. Also familiarize the students with topics like mechanism of corrosion, corrosion prevention methods, SEM, stereochemistry, polymers, desalination etc., which enable them to develop abilities and skills that are relevant to the study and practice of chemistry.

**Prerequisite:** Concepts of chemistry introduced at the plus two levels in schools

**Course outcomes:** After the completion of the course the students will be able to

<b>CO 1</b>	Apply the basic concepts of electrochemistry and corrosion to explore its possible applications in various engineering fields.
<b>CO 2</b>	Understand various spectroscopic techniques like UV-Visible, IR, NMR and its applications.
<b>CO 3</b>	Apply the knowledge of analytical method for characterizing a chemical mixture or a compound. Understand the basic concept of SEM for surface characterisation of nanomaterials.
<b>CO 4</b>	Learn about the basics of stereochemistry and its application. Apply the knowledge of conducting polymers and advanced polymers in engineering.
<b>CO 5</b>	Study various types of water treatment methods to develop skills for treating wastewater.

#### Mapping of course outcomes with program outcomes

	PO 1	PO 2	PO 3	PO 4	PO 5	PO 6	PO 7	PO 8	PO 9	PO 10	PO 11	PO 12
<b>CO 1</b>	1	2	1									
<b>CO 2</b>	1	1		1	2							
<b>CO 3</b>	1	1		1	2							
<b>CO 4</b>	2	1										
<b>CO 5</b>	1			1			3					



### Assessment Pattern

Bloom's Category	Continuous Assessment Tests		End Semester Examination
	1	2	
Remember	15	15	30
Understand	25	25	50
Apply	10	10	20
Analyse			
Evaluate			
Create			

**End Semester Examination Pattern:** There will be two parts- **Part A** and **Part B**. **Part A** contains **10** questions (**2** questions from each module), having **3** marks for each question. Students should answer **all** questions. **Part B** contains **2** questions from each module, of which student should answer any one. Each question can have maximum **2** subdivisions and carries **14** marks.

### Course Level Assessment Questions

#### Course Outcome 1 (CO 1):

1. What is calomel electrode? Give the reduction reaction (3 Marks)
2. List three important advantages of potentiometric titration (3 Marks)
3. (a) Explain how electroless plating copper and nickel are carried out (10 Marks)  
(b) Calculate the emf of the following cell at 30°C,  $Zn / Zn^{2+} (0.1M) // Ag^+ (0.01M) // Ag$ .  
Given  $E^0 Zn^{2+}/Zn = -0.76 V$ ,  $E^0 Ag^+/Ag = 0.8 V$ . (4 Marks)

#### Course Outcome 2 (CO 2)

1. State Beer Lambert's law (3 Marks)
2. List the important applications of IR spectroscopy (3 Marks)
3. (a) What is Chemical shift? What are factors affecting Chemical shift? How  $^1H$  NMR spectrum of  $CH_3COCH_2Cl$  interpreted using the concept of chemical shift. (10 Marks)  
(b) Calculate the force constant of HF molecule, if it shows IR absorption at  $4138\text{ cm}^{-1}$ . Given that atomic masses of hydrogen and fluorine are 1u and 19u respectively. (4 Marks)

#### Course Outcome 3 (CO 3):

1. Distinguish between TGA and DTA (3 Marks)
2. Give two differences between GSC and GLC (3 Marks)

3. (a) Explain the principle, instrumentation and procedure of HPLC (10 Marks)

(b) Interpret TGA of  $\text{CaC}_2\text{O}_4 \cdot \text{H}_2\text{O}$  (4 Marks)

**Course Outcome 4 (CO 4):**

1. Explain the geometrical isomerism in double bonds (3 Marks)

2. What are the rules of assigning R-S notation? (3 Marks)

3. (a) What are conducting polymers? How it is classified? Give the preparation of polyaniline (10 Marks)

(b) Draw the stereoisomers possible for  $\text{CH}_3\text{-(CHOH)}_2\text{-COOH}$  (4 Marks)

**Course Outcome 5 (CO 5):**

1. What is degree of hardness? (3 Marks)

2. Define BOD and COD (3 Marks)

3. (a) Explain the EDTA estimation of hardness (10 Marks)

(b) Standard hard water contains 20 g of  $\text{CaCO}_3$  per liter, 50 mL of this required 30 mL of EDTA solution, 50 mL of sample water required 20 mL of EDTA solution. 50 mL sample water after boiling required 14 mL EDTA solution. Calculate the temporary hardness of the given sample of water, in terms of ppm. (4 Marks)

**MODEL QUESTION PAPER**

**Total Pages:**

Reg No.: \_\_\_\_\_

Name: \_\_\_\_\_

**APJ ABDUL KALAM TECHNOLOGICAL UNIVERSITY**  
FIRST SEMESTER B.TECH DEGREE EXAMINATION

**Course Code: CYT100,**

**Course Name: ENGINEERING CHEMISTRY**

Max. Marks: 100

Duration: 3 Hours

**PART A**

**Answer all questions, each carries 3 marks**

- |   |  | Marks |
|---|--|-------|
| 1 | What is potentiometric titration? How the end point is determined graphically?   | (3)   |
| 2 | What is Galvanic series? How is it different from electrochemical series?  | (3)   |
| 3 | Which of the following molecules can give IR absorption? Give reason?<br>(a) $\text{O}_2$ (b) $\text{H}_2\text{O}$ (c) $\text{N}_2$ (d) $\text{HCl}$ | (3)   |
| 4 | Which of the following molecules show UV-Visible absorption? Give reason.<br>(a) Ethane            (b) Butadiene            (c) Benzene              | (3)   |

- 5 What are the visualization techniques used in TLC? (3)  
 6 Write the three important applications of nanomaterials. (3)  
 7 Draw the Fischer projection formula and find R-S notation of (3)

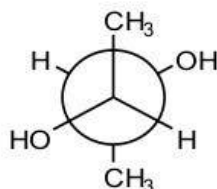

- 8 Write the structure of a) Polypyrrole b) Kevlar. (3)  
 9 What is break point chlorination? (3)  
 10 What is reverse osmosis? (3)

### PART B

**Answer any one full question from each module, each question carries 14 marks**

#### Module 1

- 11 a) Give the construction of Li-ion cell. Give the reactions that take place at the electrodes during charging and discharging. What happens to anodic material when the cell is 100% charged. (10)  
 b) Calculate the standard electrode potential of Cu, if its electrode potential at 25 °C is 0.296 V and the concentration of Cu<sup>2+</sup> is 0.015 M. (4)

**OR**

- 12 a) Explain the mechanism of electrochemical corrosion of iron in oxygen rich and oxygen deficient acidic and basic environments. (10)  
 b) Given below are reduction potentials of some species (4)

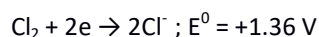

Use the above data to examine whether the acids, dil. HCl and dil. H<sub>2</sub>SO<sub>4</sub>, can be used to provide acid medium in redox titrations involving KMnO<sub>4</sub>.

#### Module 2

- 13 a) What is spin-spin splitting? Draw the NMR spectrum of (i) CH<sub>3</sub>CH<sub>2</sub>CH<sub>2</sub>Br (ii) CH<sub>3</sub>CH(Br)CH<sub>3</sub>. Explain how NMR spectrum can be used to identify the two isomers. (10)  
 b) A dye solution of concentration 0.08M shows absorbance of 0.012 at 600 nm; while a test solution of same dye shows absorbance of 0.084 under same conditions. Find the concentration of the test solution. (4)

**OR**

- 14 a) Explain the basic principle of UV-Visible spectroscopy. What are the possible electronic transitions? Explain with examples. (10)  
 b) Sketch the vibrational modes of CO<sub>2</sub> and H<sub>2</sub>O. Which of them are IR active? (4)

### Module 3

- 15 a) Explain the principle, instrumentation and procedure involved in gas chromatography. (10)  
b) Explain the DTA of  $\text{CaC}_2\text{O}_4 \cdot \text{H}_2\text{O}$  with a neat sketch. (4)

OR

- 16 a) Explain the various chemical methods used for the synthesis of nanomaterial (10)  
b) How TGA is used to analyse the thermal stability of polymers? (4)

### Module 4

- 17 a) What are conformers? Draw the *cis* and *trans* isomers of 1, 3-dimethylcyclohexane. (10)  
Which conformer (chair form) is more stable in each case?  
b) What is ABS? Give properties and applications. (4)

OR

- 18 a) Explain the various structural isomers with suitable example. (10)  
b) What is OLED? Draw a labelled diagram. (4)

### Module 5

- 19 a) What are ion exchange resins? Explain ion exchange process for removal of hardness of water? How exhausted resins are regenerated? (10)  
b) 50 mL sewage water is diluted to 2000 mL with dilution water; the initial dissolved oxygen was 7.7 ppm. The dissolved oxygen level after 5 days of incubation was 2.4 ppm. Find the BOD of the sewage. (4)

OR

- 20 a) What are the different steps in sewage treatment? Give the flow diagram. Explain the working of trickling filter. (10)  
b) Calculate the temporary and permanent hardness of a water sample which contains  $[\text{Ca}^{2+}] = 160 \text{ mg/L}$ ,  $[\text{Mg}^{2+}] = 192 \text{ mg/L}$  and  $[\text{HCO}_3^-] = 122 \text{ mg/L}$ . (4)

## Syllabus

### Module 1

#### Electrochemistry and Corrosion

Introduction - Differences between electrolytic and electrochemical cells - Daniel cell - redox reactions - cell representation. Different types of electrodes (brief) - Reference electrodes - SHE - Calomel electrode - Glass Electrode - Construction and Working. Single electrode potential - definition - Helmholtz electrical double layer - Determination of  $E^0$  using calomel electrode. Determination of pH using glass electrode. Electrochemical series and its applications. Free energy and EMF - Nernst Equation - Derivation - single electrode and cell (Numericals) - Application - Variation of emf with temperature. Potentiometric titration - Introduction - Redox titration only. Lithium ion cell - construction and working. Conductivity - Measurement of conductivity of a solution (Numericals).

Corrosion - Electrochemical corrosion - mechanism. Galvanic series - cathodic protection - electroless plating - Copper and Nickel plating.

## **Module 2**

### **Spectroscopic Techniques and Applications**

Introduction- Types of spectrum - electromagnetic spectrum - molecular energy levels - Beer Lambert's law (Numericals). UV-Visible Spectroscopy – Principle - Types of electronic transitions - Energy level diagram of ethane, butadiene, benzene and hexatriene. Instrumentation of UV-Visible spectrometer and applications. IR-Spectroscopy – Principle - Number of vibrational modes - Vibrational energy states of a diatomic molecule and -Determination of force constant of diatomic molecule (Numericals) –Applications. <sup>1</sup>H NMR spectroscopy – Principle - Relation between field strength and frequency - chemical shift - spin-spin splitting (spectral problems ) - coupling constant (definition) - applications of NMR- including MRI (brief).

## **Module 3**

### **Instrumental Methods and Nanomaterials**

Thermal analysis –TGA- Principle, instrumentation (block diagram) and applications – TGA of CaC<sub>2</sub>O<sub>4</sub>.H<sub>2</sub>O and polymers. DTA-Principle, instrumentation (block diagram) and applications - DTA of CaC<sub>2</sub>O<sub>4</sub>.H<sub>2</sub>O. Chromatographic methods - Basic principles and applications of column and TLC- Retention factor. GC and HPLC-Principle, instrumentation (block diagram) - retention time and applications.

Nanomaterials - Definition - Classification - Chemical methods of preparation - Hydrolysis and Reduction - Applications of nanomaterials - Surface characterisation -SEM – Principle and instrumentation (block diagram).

## **Module 4**

### **Stereochemistry and Polymer Chemistry**

Isomerism-Structural, chain, position, functional, tautomerism and matamerism - Definition with examples - Representation of 3D structures-Newman, Sawhorse, Wedge and Fischer projection of substituted methane and ethane. Stereoisomerism - Geometrical isomerism in double bonds and cycloalkanes (cis-trans and E-Z notations). R-S Notation – Rules and examples - Optical isomerism, Chirality, Enantiomers and Diastereoisomers-Definition with examples.Conformational analysis of ethane, butane, cyclohexane, mono and di methyl substituted cyclohexane.

Copolymers - Definition - Types - Random, Alternating, Block and Graft copolymers - ABS - preparation, properties and applications.Kevlar-preparation, properties and applications.Conducting polymers - Doping -Polyaniline and Polypyrrole - preparation properties and applications. OLED - Principle, construction and advantages.

## **Module 5**

### **Water Chemistry and Sewage Water Treatment**

Water characteristics - Hardness - Types of hardness- Temporary and Permanent - Disadvantages of hard water -Units of hardness- ppm and mg/L -Degree of hardness (Numericals) - Estimation of

hardness-EDTA method (Numericals). Water softening methods-Ion exchange process-Principle, procedure and advantages. Reverse osmosis – principle, process and advantages. Municipal water treatment (brief) - Disinfection methods - chlorination, ozone and UV irradiation.

Dissolved oxygen (DO) -Estimation (only brief procedure-Winkler's method), BOD and COD-definition, estimation (only brief procedure) and significance (Numericals). Sewage water treatment - Primary, Secondary and Tertiary - Flow diagram -Trickling filter and UASB process.

#### **Text Books**

1. B. L. Tembe, Kamaluddin, M. S. Krishnan, "Engineering Chemistry (NPTEL Web-book)", 2018.
2. P. W. Atkins, "Physical Chemistry", Oxford University Press, 10<sup>th</sup> edn., 2014.

#### **Reference Books**

1. C. N. Banwell, "Fundamentals of Molecular Spectroscopy", McGraw-Hill, 4<sup>th</sup> edn., 1995.
2. Donald L. Pavia, "Introduction to Spectroscopy", Cengage Learning India Pvt. Ltd., 2015.
3. B. R. Puri, L. R. Sharma, M. S. Pathania, "Principles of Physical Chemistry", Vishal Publishing Co., 47<sup>th</sup> Edition, 2017.
4. H. H. Willard, L. L. Merritt, "Instrumental Methods of Analysis", CBS Publishers, 7<sup>th</sup> Edition, 2005.
5. Ernest L. Eliel, Samuel H. Wilen, "Stereo-chemistry of Organic Compounds", WILEY, 2008.
6. Raymond B. Seymour, Charles E. Carraher, "Polymer Chemistry: An Introduction", Marcel Dekker Inc; 4th Revised Edition, 1996.
7. Muhammed Arif, Annette Fernandez, Kavitha P. Nair "Engineering Chemistry", Owl Books, 2019.
8. Ahad J., "Engineering Chemistry", Jai Publication, 2019.
9. Roy K. Varghese, "Engineering Chemistry", Crownplus Publishers, 2019.
10. Soney C. George, Rino Laly Jose, "Text Book of Engineering Chemistry", S. Chand & Company Pvt Ltd, 2019.

### Course Contents and Lecture Schedule

No	Topic	No. of Lectures (hrs)
<b>1</b>	<b>Electrochemistry and Corrosion</b>	<b>9</b>
<b>1.1</b>	Introduction - Differences between electrolytic and electrochemical cells- Daniel cell - redox reactions - cell representation. Different types of electrodes (brief) - Reference electrodes- SHE - Calomel electrode - Glass Electrode - Construction and Working.	<b>2</b>
<b>1.2</b>	Single electrode potential – definition - Helmholtz electrical double layer - Determination of $E^0$ using calomel electrode. Determination of pH using glass electrode. Electrochemical series and its applications. Free energy and EMF - Nernst Equation – Derivation - single electrode and cell (Numericals) -Application -Variation of emf with temperature.	<b>3</b>
<b>1.3</b>	Potentiometric titration - Introduction -Redox titration only. Lithiumion cell - construction and working. Conductivity- Measurement of conductivity of a solution (Numericals).	<b>2</b>
<b>1.4</b>	Corrosion-Electrochemicalcorrosion – mechanism. Galvanic series- cathodic protection - electroless plating –Copper and Nickel plating.	<b>2</b>
<b>2</b>	<b>Spectroscopic Techniques and Applications</b>	<b>9</b>
<b>2.1</b>	Introduction- Types of spectrum - electromagnetic spectrum - molecular energy levels - Beer Lambert’s law (Numericals).	<b>2</b>
<b>2.2</b>	UV-Visible Spectroscopy – Principle - Types of electronic transitions - Energy level diagram of ethane, butadiene, benzene and hexatriene. Instrumentation of UV-Visible spectrometer and applications.	<b>2</b>
<b>2.3</b>	IR-Spectroscopy – Principle - Number of vibrational modes -Vibrational energy states of a diatomic molecule and -Determination of force constant of diatomic molecule (Numericals) –Applications.	<b>2</b>
<b>2.4</b>	$^1\text{H}$ NMR spectroscopy – Principle - Relation between field strength and frequency - chemical shift - spin-spin splitting (spectral problems ) - coupling constant (definition) - applications of NMR- including MRI (brief).	<b>3</b>
<b>3</b>	<b>Instrumental Methods and Nanomaterials</b>	<b>9</b>
<b>3.1</b>	Thermal analysis –TGA- Principle, instrumentation (block diagram) and applications – TGA of $\text{CaC}_2\text{O}_4 \cdot \text{H}_2\text{O}$ and polymers. DTA-Principle, instrumentation (block diagram) and applications - DTA of $\text{CaC}_2\text{O}_4 \cdot \text{H}_2\text{O}$ .	<b>2</b>

<b>3.2</b>	Chromatographic methods - Basic principles and applications of column and TLC- Retention factor.	<b>2</b>
<b>3.3</b>	GC and HPLC-Principle, instrumentation (block diagram) - retention time and applications.	<b>2</b>
<b>3.4</b>	Nanomaterials - Definition - Classification - Chemical methods of preparation - Hydrolysis and Reduction - Applications of nanomaterials - Surface characterisation -SEM – Principle and instrumentation (block diagram).	<b>3</b>
<b>4</b>	<b>Stereochemistry and Polymer Chemistry</b>	<b>9</b>
<b>4.1</b>	Isomerism-Structural, chain, position, functional, tautomerism and matamerism - Definition with examples - Representation of 3D structures-Newman, Sawhorse, Wedge and Fischer projection of substituted methane and ethane. Stereoisomerism - Geometrical isomerism in double bonds and cycloalkanes (cis-trans and E-Z notations).	<b>2</b>
<b>4.2</b>	R-S Notation – Rules and examples - Optical isomerism, Chirality, Enantiomers and Diastereoisomers-Definition with examples.	<b>1</b>
<b>4.3</b>	Conformational analysis of ethane, butane, cyclohexane, mono and di methyl substituted cyclohexane.	<b>2</b>
<b>4.4</b>	Copolymers - Definition - Types - Random, Alternating, Block and Graft copolymers - ABS - preparation, properties and applications. Kevlar-preparation, properties and applications. Conducting polymers - Doping -Polyaniline and Polypyrrole - preparation properties and applications. OLED - Principle, construction and advantages.	<b>4</b>
<b>5</b>	<b>Water Chemistry and Sewage Water Treatment</b>	<b>9</b>
<b>5.1</b>	Water characteristics - Hardness - Types of hardness- Temporary and Permanent - Disadvantages of hard water -Units of hardness- ppm and mg/L -Degree of hardness (Numericals) - Estimation of hardness-EDTA method (Numericals). Water softening methods-Ion exchange process-Principle, procedure and advantages. Reverse osmosis – principle, process and advantages.	<b>3</b>
<b>5.2</b>	Municipal water treatment (brief) - Disinfection methods - chlorination, ozone andUV irradiation.	<b>2</b>
<b>5.3</b>	Dissolved oxygen (DO) -Estimation (only brief procedure-Winkler’s method), BOD and COD-definition, estimation (only brief procedure) and significance (Numericals).	<b>2</b>
<b>5.4</b>	Sewage water treatment - Primary, Secondary and Tertiary - Flow diagram - Trickling filter and UASB process.	<b>2</b>



COURSE CODE	COURSE NAME	CATEGORY	L	T	P	CREDITS
22EST104	ENGINEERING MECHANICS	ES	2	1	0	3

**Preamble:** Goal of this course is to expose the students to the fundamental concepts of mechanics and enhance their problem-solving skills. It introduces students to the influence of applied force system and the geometrical properties of the rigid bodies while stationary or in motion. After this course students will be able to recognize similar problems in real-world situations and respond accordingly.

**Prerequisite:** Nil

**Course Outcomes:** After completion of the course the student will be able to:

<b>CO 1</b>	Recall principles and theorems related to rigid body mechanics
<b>CO 2</b>	Identify and describe the components of system of forces acting on the rigid body
<b>CO 3</b>	Apply the conditions of equilibrium to various practical problems involving different force system.
<b>CO 4</b>	Choose appropriate theorems, principles or formulae to solve problems of mechanics.
<b>CO 5</b>	Solve problems involving rigid bodies, applying the properties of distributed areas and masses

**Mapping of course outcomes with program outcomes (Minimum requirement)**

	PO 1	PO 2	PO 3	PO 4	PO 5	PO 6	PO 7	PO 8	PO 9	PO 10	PO 11	PO 12
<b>CO 1</b>	2	2	-	-	-	-	-	-	-	-	-	-
<b>CO 2</b>	3	3	-	-	-	-	-	-	-	-	-	-
<b>CO 3</b>	3	3	-	-	-	-	-	-	-	-	-	-
<b>CO 4</b>	3	3	-	-	-	-	-	-	-	-	-	-
<b>CO 5</b>	3	3	-	-	-	-	-	-	-	-	-	-

**Assessment Pattern**

Bloom's Category	Continuous Assessment Tests		End Semester Examination (Marks)
	Test 1 (Marks)	Test 2 (Marks)	
Remember	10	10	15
Understand	10	10	15
Apply	30	30	70
Analyse			
Evaluate			
Create			

### Mark distribution

Total Marks	CIE marks	ESE marks	ESE Duration
150	50	100	3 hours

#### Continuous Internal Evaluation Pattern:

Attendance	: 10 marks
Continuous Assessment Test (2 numbers)	: 25 marks
Assignment/Quiz/Course project	: 15 marks

**End Semester Examination Pattern:** There will be two parts; Part A and Part B. Part A contain 10 questions with 2 questions from each module, having 3 marks for each question. Students should answer all questions. Part B contains 2 questions from each module of which student should answer any one. Each question can have maximum 2 sub-divisions and carry 14 marks.

#### Course Level Assessment Questions:

##### Part A

**Course Outcome 1 (CO1): (One question from each module to meet the course objective 1: To recall principles and theorems related to rigid body mechanics)**

1. Explain D'Alembert's principle
2. Distinguish static and dynamic friction
3. State and explain perpendicular axis theorem

**Course Outcome 2 (CO2) (One question from each module to meet the course objective 2: To identify and describe the components of system of forces acting on the rigid body)**

1. A simply supported beam AB of span 5 m is carrying point loads 5 kN, 3 kN and 2 kN at 1m, 3m and 4m respectively from support A. Calculate the support reaction at B.
2. A gymnast holding onto a bar, is suspended motionless in mid-air. The bar is supported by two ropes that attach to the ceiling. Diagram the forces acting on the combination of gymnast and bar
3. While you are riding your bike, you turn a corner following a circular arc. Illustrate the forces that act on your bike to keep you along the circular path ?

##### Part B

All the questions under this section shall assess the learning levels corresponding to the course outcomes listed below.

<b>CO 3</b>	To apply the conditions of equilibrium to various practical problems involving different force system.
<b>CO 4</b>	To choose appropriate theorems, principles or formulae to solve problems of mechanics.
<b>CO 5</b>	To solve problems involving rigid bodies, applying the properties of distributed areas and masses

1. Two rollers each of weight 100 N are supported by an inclined plane and a vertical wall. Find the reaction at the points of contact A, B, C. Assume all the surfaces to be smooth.

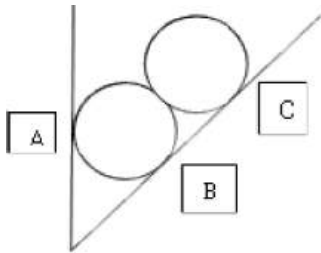

<b>Course outcome identifier</b>	<b>Description of course outcome</b>	<b>Learning level assessed</b>	<b>Marks allocated</b>
<b>CO 3</b>	To apply the conditions of equilibrium to various practical problems involving different force system.	Applying – (Sketch the free body diagram that represent equilibrium state of the body )	4
<b>CO 4</b>	To choose appropriate theorems, principles or formulae to solve problems of mechanics.	Applying (Choose the equations and formulae required for calculation)	4
<b>CO 5</b>	To solve problems involving rigid bodies, applying the properties of distributed areas and masses	Applying ( Solve the problem based on the descriptions given in CO3 and CO4)	6
Total			14

2. A cylindrical disc, 50 cm diameter and cm thickness, is in contact with a horizontal conveyer belts running at uniform speeds of 5 m/s. Assuming there is no slip at points of contact determine (i) angular velocity of disc (ii) Angular acceleration of disc if velocity of conveyer changes to 8 m/s. Also compute the moment acting about the axis of the disc in both cases.

Course outcome identifier	Description of course outcome	Learning level assessed	Marks allocated
CO 3	To apply the conditions of equilibrium to various practical problems involving different force system.	Applying – (Sketch the free body diagram that represent state of the body )	4
CO 4	To choose appropriate theorems, principles or formulae to solve problems of mechanics.	Applying (Choose the equations and formulae required for calculation)	4
CO 5	To solve problems involving rigid bodies, applying the properties of distributed areas and masses	Applying ( Solve the problem based on the descriptions given in CO3 and CO4)	6
Total			14

3. Determine the centroid of the given section

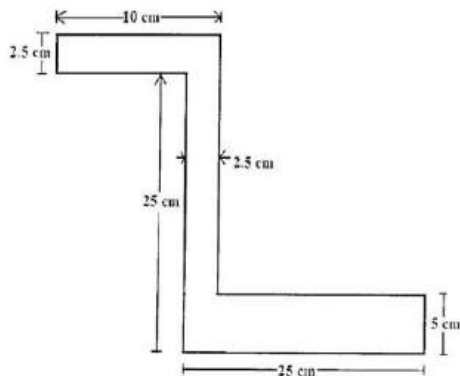

Course outcome identifier	Description of course outcome	Learning level assessed	Marks allocated
CO 3	To apply the conditions of equilibrium to various practical problems involving different force system.	Applying – (Illustrate the computation of centroid for the given geometrical shape)	4
CO 4	To choose appropriate theorems, principles or formulae to solve problems of mechanics.	Applying (Choose the equations and formulae required for calculation)	4
CO 5	To solve problems involving rigid bodies, applying the properties of distributed	Applying ( Solve the problem based on the descriptions	6

	areas and masses	given in CO3 and CO4)	
Total			14

4. A rectangular hole is made in a triangular section as shown. Find moment of inertia about the section x-x passing through the CG of the section and parallel to BC.

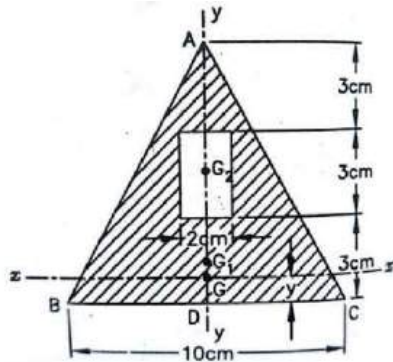

Course outcome identifier	Description of course outcome	Learning level assessed	Marks allocated
CO 3	To apply the conditions of equilibrium to various practical problems involving different force system.	Applying – (Illustrate the computation of moment of inertia for the given geometrical shape)	4
CO 4	To choose appropriate theorems, principles or formulae to solve problems of mechanics.	Applying (Choose the equations and formulae required for calculation)	4
CO 5	To solve problems involving rigid bodies, applying the properties of distributed areas and masses	Applying ( Solve the problem based on the descriptions given in CO3 and CO4)	6
Total			14

**Model Question Paper**

**QP CODE:**

Reg No.: \_\_\_\_\_

Name: \_\_\_\_\_

**APJ ABDUL KALAM TECHNOLOGICAL UNIVERSITY FIRST SEMESTER B.TECH DEGREE EXAMINATION,  
MONTH & YEAR**

**Course Code: EST 100**

**ENGINEERING MECHANICS**

Max. Marks: 100

Duration: 3 hours

**Part A**

(Answer all questions; each question carries 3 marks)

1. Explain D'Alembert's principle
2. Distinguish static and dynamic friction.
3. State and explain perpendicular axis theorem.
4. A simply supported beam AB of span 5 m is carrying point loads 5 kN, 3 kN and 2 kN at 1m, 3m and 4m respectively from support A. Calculate the support reaction at B.
5. A gymnast holding onto a bar, is suspended motionless in mid-air. The bar is supported by two ropes that attach to the ceiling. Diagram the forces acting on the combination of gymnast and bar
6. While you are riding your bike, you turn a corner following a circular arc. Illustrate the forces that act on your bike to keep you along the circular path ?
7. Compare damped and undamped free vibrations.
8. State the equation of motion of a rotating rigid body, rotating about its fixed axis.
9. Illustrate the significance of instantaneous centre in the analysis of rigid body undergoing rotational motion.
10. Highlight the principles of mechanics applied in the evaluation of elastic collision of rigid bodies.

**PART B**

(Answer **one full** question from each module, each question carries **14** marks)

**Module -I**

11. Two identical rollers each of weight 100 N are supported by an inclined plane, making an angle of  $30^\circ$  with the vertical, and a vertical wall. Find the reaction at the points of contact A, B, C. Assume all the surfaces to be smooth. (14 marks)

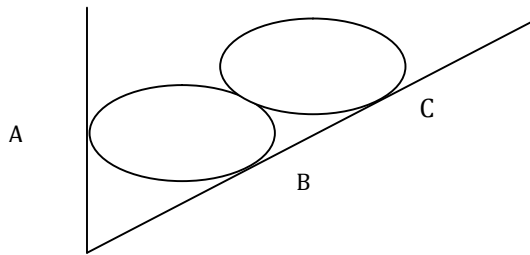

12. A string tied to a wall is made to pass over a pulley placed 2m away from it. A weight P is attached to the string such that the string stretches by 2m from the support on the wall to the location of attachment of weight. Determine the force P required to maintain 200 kg body in position for  $\theta = 30^\circ$ , The diameter of pulley B is negligible. (14 marks)

**Module – 2**

13. Two blocks A & B are resting against a wall and the floor as shown in figure below. Find the value of horizontal force P applied to the lower block that will hold the system in equilibrium. Coefficient of friction are : 0.25 at the floor, 0.3 at the wall and 0.2 between the blocks.

(14 marks)

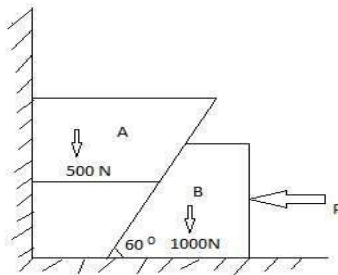

14. A beam is hinged at A and roller supported at B. It is acted upon by loads as shown below. Find the reactions at A & B. (14 marks)

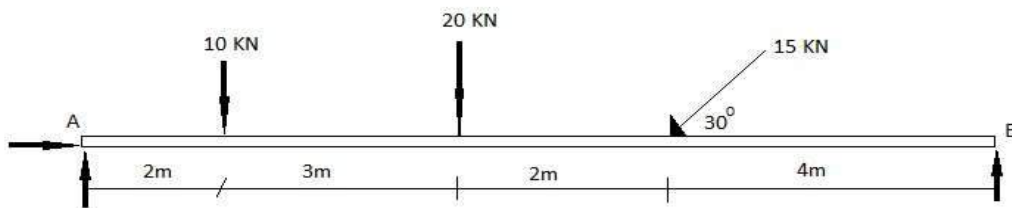

**Module – 3**

15. A rectangular hole is made in a triangular section as shown. Find moment of inertia about the section x-x passing through the CG of the section and parallel to BC. (14 marks)

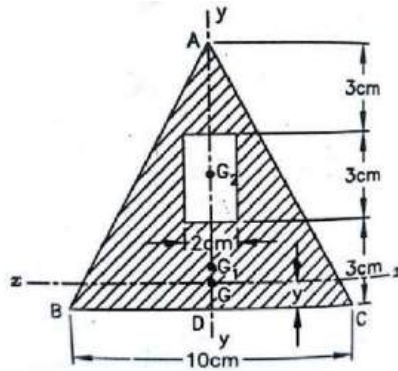

16. Support A has ball and socket connection. Roller support at B prevents motion in the  $-z$  direction. Corner C is tied to D by a rope. The triangle is weightless. Determine the unknown force components acting at A, B, and C. (14 marks)

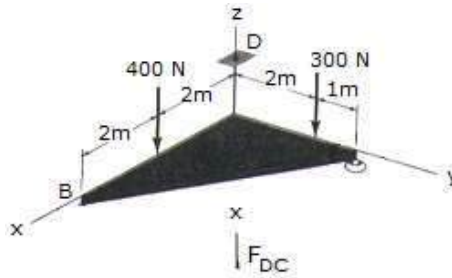

**Module - 4**

17. A cricket ball is thrown by a fielder from a height of 2m at an angle of  $30^\circ$  to the horizontal with an initial velocity of 20 m/s, hits the wickets at a height of 0.5 m from the ground. How far was the fielder from the wicket? (14 marks)

18. An engine of weight 500 kN pull a train weighing 1500 kN up an incline of 1 in 100. The train starts from rest and moves with constant acceleration against a resistance of 5 N/kN. It attains a maximum speed of 36 kmph in 1 km distance. Determine the tension in the coupling between train and engine and the traction force developed by the engine. (14marks)

**Module – 5**

19. A cylindrical disc, 50 cm diameter and 10 cm thickness having mass of 10 kg, is in contact with a horizontal conveyor belt running at uniform speeds of 5 m/s. Assuming there is no slip at points of contact determine (i) angular velocity of disc (ii) Angular acceleration of disc if velocity of conveyor changes to 8 m/s in 10 seconds. Also compute the moment acting about the axis of the disc in both cases. (14 marks)

20. A wheel rotating about fixed axis at 20 rpm is uniformly accelerated for 70 seconds during which time it makes 50 revolutions. Find the (i) angular velocity at the end of this interval and (ii) time required for the velocity to reach 100 revolutions per minute. (14 marks)



## SYLLABUS

### Module 1

Introduction to Engineering Mechanics-statics-basic principles of statics-Parallelogram law, equilibrium law, principles of superposition and transmissibility, law of action and reaction(review) free body diagrams.

Concurrent coplanar forces-composition and resolution of forces-resultant and equilibrium equations – methods of projections – methods of moments – Varignon’s Theorem of moments.

### Module 2

Friction – sliding friction - Coulomb’s laws of friction – analysis of single bodies –wedges, ladder-analysis of connected bodies .

Parallel coplanar forces – couple - resultant of parallel forces – centre of parallel forces – equilibrium of parallel forces – Simple beam subject to concentrated vertical loads. General coplanar force system - resultant and equilibrium equations.

### Module 3

Centroid of composite areas- – moment of inertia-parallel axis and perpendicular axis theorems. Polar moment of inertia, radius of gyration, mass moment of inertia-ring, cylinder and disc.

Theorem of Pappus Guldinus(demonstration only)

Forces in space - vectorial representation of forces, moments and couples –resultant and equilibrium equations – concurrent forces in space (simple problems only)

### Module 4

Dynamics – rectilinear translation - equations of kinematics(review)

kinetics – equation of motion – D’Alembert’s principle. – motion on horizontal and inclined surfaces, motion of connected bodies. Impulse momentum equation and work energy equation (concepts only).

Curvilinear translation - equations of kinematics –projectile motion(review), kinetics – equation of motion. Moment of momentum and work energy equation (concepts only).

### Module 5

Rotation – kinematics of rotation- equation of motion for a rigid body rotating about a fixed axis – rotation under a constant moment.

Plane motion of rigid body – instantaneous centre of rotation (concept only).

Simple harmonic motion – free vibration –degree of freedom- undamped free vibration of spring mass system-effect of damping(concept only)

### Text Books

1. Timoshenko and Young, Engineering Mechanics, McGraw Hill Publishers
2. Shames, I. H., Engineering Mechanics - Statics and Dynamics, Prentice Hall of India.
3. R. C. Hibbeler and Ashok Gupta, Engineering Mechanics, Vol. I statics, Vol II Dynamics, Pearson Education.

## References

1. Merriam J. L and Kraige L. G., Engineering Mechanics - Vols. 1 and 2, John Wiley.
2. Tayal A K, Engineering Mechanics – Statics and Dynamics, Umesh Publications
3. Bhavikkatti, S.S., Engineering Mechanics, New Age International Publishers
4. F.P.Beer and E.R.Johnston (2011), Vector Mechanics for Engineers, Vol.I-Statics, Vol.II-Dynamics, 9<sup>th</sup> Ed, Tata McGraw Hill
5. Rajasekaran S and Sankarasubramanian G, Engineering Mechanics - Statics and Dynamics, Vikas Publishing House Pvt Ltd.

## Course Contents and Lecture Schedule:

Module	Topic	Course outcomes addressed	No. of Hours
<b>1</b>	<b>Module 1</b>		<b>Total: 7</b>
1.1	Introduction to engineering mechanics – introduction on statics and dynamics - Basic principles of statics – Parellogram law, equilibrium law – Superposition and transmissibility, law of action and reaction (review the topics)	CO1 and CO2	1
1.2	Free body diagrams. Degree of freedom-types of supports and nature of reactions - exercises for free body diagram preparation – composition and resolution of forces, resultant and equilibrium equations (review the topics) - numerical exercises for illustration.	CO1 and CO2	1
1.3	Concurrent coplanar forces - analysis of concurrent forces -methods of projections – illustrative numerical exercise – teacher assisted problem solving.	CO1 and CO2	1
1.4	Analysis of concurrent forces -methods of moment-Varignon’s Theorem of Moments - illustrative numerical exercise– teacher assisted problem solving.	CO1 and CO2	1
1.5	Analysis of concurrent force systems – extended problem solving - Session I.	CO3,CO4 and CO5	1
1.6	Analysis of concurrent force systems – extended problem solving - Session II – learning review quiz.	CO3,CO4 and CO5	1
1.7	Analysis of concurrent force systems – extended problem solving - Session III.	CO3,CO4 and CO5	1
<b>2</b>	<b>Module 2</b>		<b>Total: 7</b>
2.1	Friction – sliding friction - Coulomb’s laws of friction – analysis of single bodies –illustrative examples on wedges and ladder-teacher	CO1 and CO2	1

	assisted problem solving tutorials using problems from wedges and ladder.		
2.2	Problems on friction - analysis of connected bodies. illustrative numerical exercise– teacher assisted problem solving.	CO3, CO4 and CO5	1
2.3	Problems on friction-extended problem solving	CO3,CO4 and CO5	1
2.4	Parallel coplanar forces – couple - resultant of parallel forces – centre of parallel forces – equilibrium of parallel forces – Simple beam subject to concentrated vertical loads.	CO1 and CO2	1
2.5	General coplanar force system - resultant and equilibrium equations - illustrative examples- teacher assisted problem solving.	CO1 and CO2	1
2.6	General coplanar force system-resultant and equilibrium equations - illustrative examples	CO3, CO4 and CO5	1
2.7	General coplanar force system - Extended problem solving - Quiz to evaluate learning level.	CO3, CO4 and CO5	1
<b>3</b>	<b>Module 3</b>		<b>Total: 7</b>
3.1	Centroid of simple and regular geometrical shapes – centroid of figures in combination - composite areas- examples for illustration – problems for practice to be done by self.	CO1 and CO2	1
3.2	Moment of inertia- parallel axis theorem –examples for illustration - problems for practice to be done by self.	CO1 and CO2	1
3.3	Moment of inertia - perpendicular axis theorem - example for illustration to be given as hand out and discussion on the solved example.	CO1 and CO2	1
3.4	Solutions to practice problems – problems related to centroid and moment of inertia - problems for practice to be done by self.	CO3, CO4 and CO5	1
3.5	Polar moment of inertia, Radius of gyration. Mass moment of inertia of ring, cylinder and uniform disc. Theorem of Pappus Guldinus - Demonstration	CO1 and CO2	1
3.6	Introduction to forces in space – vectorial representation of forces, moments and couples – simple problems to illustrate vector representations of forces, moments and couples to be done in class.	CO1,and CO2	1
3.7	Solution to practice problems - resultant and equilibrium equations for concurrent forces in space – concurrent forces in space - 2 simple problems to illustrate the application of resultant and equilibrium equations for concurrent forces in space.	CO3,CO4 and CO5	1
<b>4</b>	<b>Module 4</b>		<b>Total: 7</b>

4.1	Introduction to dynamics – review of rectilinear translation - equations of kinematics – problems to review the concepts – additional problems involving extended application as exercises .	CO1 and CO2	1
4.2	Solutions to exercises with necessary explanation given as hand out – introduction to kinetics – equation of motion – D’Alembert’s principle – illustration of the concepts using one numerical exercise from motion on horizontal and inclined surfaces.	CO1 and CO2	1
4.3	Motion of connected bodies - example for illustration to be given as hand out and discussion on the solved example – problems for practice to be done by self.	CO3, CO4 and CO5	1
4.4	Motion of connected bodies-extended problem solving.	CO3, CO4 & CO5	1
4.5	Curvilinear translation - Review of kinematics –projectile motion – simple problems to review the concepts – introduction to kinetics – equation of motion – illustration of the concepts using numerical exercises.	CO3, CO4 & CO5	1
4.6	Extended problem solving – rectilinear and curvilinear translation.	CO3, CO4 & CO5	1
4.7	Concepts on Impulse momentum equation and work energy equation (rectilinear translation – discussions to bring out difference between elastic and inelastic collisions). Concepts on Moment of momentum and work energy equation (curvilinear translation).	CO1 and CO2	1
<b>5</b>	<b>Module 5</b>		<b>Total: 7</b>
5.1	Rotation – kinematics of rotation- equation of motion for a rigid body rotating about a fixed axis – simple problems for illustration.	CO1 and CO2	1
5.2	Rotation under a constant moment – teacher assisted problem solving.	CO3,CO4 and CO5	1
5.3	Rotation under a constant moment - extended problem solving.	CO3, CO4 and CO5	1
5.4	Plane motion of rigid body- instantaneous centre of rotation (concept only).	CO1 and CO2	1
5.5	Introduction to harmonic oscillation –free vibrations - simple harmonic motion – differential equation and solution.  Degree of freedom – examples of single degree of freedom (SDOF) systems – Idealisation of mechanical systems as spring-mass systems (concept only).	CO1 and CO2	1

5.6	SDOF spring mass system –equation of motion – undamped free vibration response - concept of natural frequency. Free vibration response due to initial conditions. Simple problems on determination of natural frequency and free vibration response to test the understanding level.	CO1 and CO2	1
5.7	Free vibration analysis of SDOF spring-mass systems – Problem solving Effect of damping on free vibration response (concept only).	CO1and CO2	1

COURSE CODE	COURSE NAME	CATEGORY	L	T	P	CREDITS
22EST105	ENGINEERING GRAPHICS	ES	2	0	2	3

**Preamble:** To enable the student to effectively perform technical communication through graphical representation as per global standards.

**Prerequisite:** NIL

**Course Outcomes:** After the completion of the course the student will be able to

<b>CO 1</b>	Draw the projection of points and lines located in different quadrants
<b>CO 2</b>	Prepare multiview orthographic projections of objects by visualizing them in different positions
<b>CO 3</b>	Draw sectional views and develop surfaces of a given object
<b>CO 4</b>	Prepare pictorial drawings using the principles of isometric and perspective projections to visualize objects in three dimensions.
<b>CO 5</b>	Convert 3D views to orthographic views
<b>CO 6</b>	Obtain multiview projections and solid models of objects using CAD tools

#### Mapping of course outcomes with program outcomes

	PO 1	PO 2	PO 3	PO 4	PO 5	PO 6	PO 7	PO 8	PO 9	PO 10	PO 11	PO 12
<b>CO 1</b>	3											
<b>CO 2</b>	3											
<b>CO 3</b>	3	1										
<b>CO 4</b>	3									1		
<b>CO 5</b>	3									2		
<b>CO 6</b>	3				3					3		

#### Assessment Pattern

Bloom's Category	Continuous Assessment Tests		End Semester Examination (100 Marks)
	Test 1 (15 Marks)	Test 2 (15 Marks)	
Remember			
Understand	5		20
Apply	10	10	80
Analyse			
Evaluate			
Create			

### Mark distribution

Total Marks	CIE (Marks)	ESE (Marks)	ESE Duration
150	50	100	3 hours

### Continuous Internal Evaluation Pattern:

Attendance : 10 marks

CIA for section A carries 25 marks (15 marks for 1 test and Class work 10 marks)

CIA for section B carries 15 marks (10 marks for 1 test and Class work 5 marks)

### End Semester Examination Pattern:

ESE will be of 3 hour duration on A4 size answer booklet and will be for 100 marks. The question paper shall contain two questions from each module of Section A only. Student has to answer any one question from each module. Each question carries 20 marks.

### Course Level Assessment Questions

(Questions may be framed based on the outline given under each course outcome)

#### Course Outcome 1 (CO1):

1. Locate points in different quadrants as per given conditions.
2. Problems on lines inclined to both planes .
3. Find True length, Inclinations and Traces of lines.

#### Course Outcome 2 (CO2)

1. Draw orthographic views of solids and combination solids
2. Draw views of solids inclined to any one reference plane.
3. Draw views of solids inclined to both reference planes.

#### Course Outcome 3 (CO3):

1. Draw views of solids sectioned by a cutting plane
2. Find location and inclination of cutting plane given true shape of the section
3. Draw development of lateral surface of solids and also its sectioned views

#### Course Outcome 4 (CO4):

1. Draw Isometric views/projections of solids
2. Draw Isometric views/projections of combination of solids
3. Draw Perspective views of Solids

#### Course Outcome 5 (CO5):

1. Draw Orthographic views of solids from given three dimensional view

**Course Outcome 6 (CO6):**

1. Draw the given figure including dimensions using 2D software
2. Create 3D model using modelling software from the given orthographic views or 3D figure or from real 3D objects

**Model Question paper**

**QP CODE:**

**PAGES:3**

Reg No: \_\_\_\_\_

Name : \_\_\_\_\_

**APJ ABDUL KALAM TECHNOLOGICAL UNIVERSITY FIRST SEMESTER B.TECH DEGREE EXAMINATION,  
MONTH & YEAR**

**Course Code: EST 110**

**ENGINEERING GRAPHICS**

**Max.Marks:100**

**Duration: 3 Hours**

**PART A**

**Answer all Questions. Each question carries 3 Marks**

**Instructions: Retain necessary Construction lines**

**Show necessary dimensions**

**Answer any ONE question from each module**

**Each question carries 20 marks**

**MODULE I**

1. The end point A of a line is 20mm above HP and 10mm in front of VP. The other end of the line is 50mm above HP and 15mm behind VP. The distance between the end projectors is 70mm. Draw the projections of the line. Find the true length and true inclinations of the line with the principal planes. Also locate the traces of the line.
2. One end of a line is 20mm from both the principal planes of projection. The other end of the line is 50mm above HP and 40mm in front of VP. The true length of the line is 70mm. Draw the projections of the line. Find its apparent inclinations, elevation length and plan length. Also locate its traces.

**MODULE II**

3. A pentagonal pyramid of base side 25mm and height 40mm, is resting on the ground on one of its triangular faces. The base edge of that face is inclined  $30^\circ$  to VP. Draw the projections of the solid.





Time : 3 hours

EST110 ENGINEERING GRAPHICS

Max. Marks: 100

**SCHEME OF VALUATION**

1. Locating the points and drawing the projections of the line – 4 marks  
Finding true length by any one method – 6 marks  
Finding true inclination with VP – 2 marks  
Finding true inclination with HP – 2 marks  
Locating horizontal trace – 2 marks  
Locating vertical trace – 2 marks  
Dimensioning and neatness – 2 marks

Total = 20 marks

2. Locating the points and drawing true length of the line – 4 marks  
Finding projections by any method – 6 marks  
Finding length of elevation and plan – 2 marks  
Finding apparent inclinations – 2 marks  
Locating horizontal trace – 2 marks  
Locating vertical trace – 2 marks  
Dimensioning and neatness – 2 marks

Total = 20 marks

3. Drawing initial position plan and elevation – 4 marks  
First inclination views – 4 marks  
Second inclination views -8 marks  
Marking invisible edges – 2 marks  
Dimensioning and neatness – 2 marks

Total = 20 marks

*(Any one method or combination of methods for solving can be used.*

*If initial position is wrong then maximum 50% marks may be allotted for the answer)*

4. Drawing initial position plan and elevation – 4 marks  
First inclination views – 4 marks  
Second inclination views -8 marks  
Marking invisible edges – 2 marks  
Dimensioning and neatness – 2 marks

Total = 20 marks

*(Any one method or combination of methods for solving can be used*

*If initial position is wrong then maximum 50% marks may be allotted for the answer)*

5. Drawing initial position plan and elevation – 4 marks  
Locating section plane as per given condition – 5 marks  
Drawing true shape -5 marks  
Finding inclination of cutting plane – 2 marks  
Dimensioning and neatness – 2 marks

Total = 20 marks

6. Drawing initial position plan and elevation – 4 marks  
Development of the pyramid – 6 marks

Locating string in development -2 marks  
Locating string in elevation – 3 marks  
Locating string in plan – 3 marks  
Dimensioning and neatness – 2 marks

Total = 20 marks

7. Drawing initial positions – 4 marks  
Isometric View of Slab -6 marks  
Isometric View of Frustum – 10 marks  
Dimensioning and neatness – 2 marks

Total = 20 marks

*(Initial position is optional, hence redistribute if needed.  
Reduce 4 marks if Isometric scale is taken)*

8. Drawing initial positions – 4 marks  
Isometric scale – 4 marks  
Isometric projection of prism -5 marks  
Isometric projection of sphere – 5 marks  
Dimensioning and neatness – 2 marks

Total = 20 marks

*(Initial position is optional, hence redistribute if needed.*

9. Drawing the planes and locating the station point – 4 marks  
Locating elevation points – 2 marks  
Locating plan points – 2 marks  
Drawing the perspective view – 10 marks  
Dimensioning and neatness – 2 marks

Total = 20 marks

10. Drawing the elevation – 8marks  
Drawing the plan – 4 marks  
Drawing the side view – 4 marks  
Marking invisible edges – 2 marks  
Dimensioning and neatness – 2 marks

Total = 20 marks

## SYLLABUS

General Instructions:

- First angle projection to be followed
- Section A practice problems to be performed on A4 size sheets
- Section B classes to be conducted on CAD lab

### SECTION A

#### Module 1

Introduction : Relevance of technical drawing in engineering field. Types of lines, Dimensioning, BIS code of practice for technical drawing.

Orthographic projection of Points and Lines: Projection of points in different quadrants, Projection of straight lines inclined to one plane and inclined to both planes. Trace of line. Inclination of lines with reference planes True length of line inclined to both the reference planes.

#### Module 2

Orthographic projection of Solids: Projection of Simple solids such as Triangular, Rectangle, Square, Pentagonal and Hexagonal Prisms, Pyramids, Cone and Cylinder. Projection of solids in simple position including profile view. Projection of solids with axis inclined to one of the reference planes and with axis inclined to both reference planes.

#### Module 3

Sections of Solids: Sections of Prisms, Pyramids, Cone, Cylinder with axis in vertical position and cut by different section planes. True shape of the sections. Also locating the section plane when the true shape of the section is given.

Development of Surfaces: Development of surfaces of the above solids and solids cut by different section planes. Also finding the shortest distance between two points on the surface.

#### Module 4

Isometric Projection: Isometric View and Projections of Prisms, Pyramids, Cone , Cylinder, Frustum of Pyramid, Frustum of Cone, Sphere, Hemisphere and their combinations.

#### Module 5

Perspective Projection: Perspective projection of Prisms and Pyramids with axis perpendicular to the ground plane, axis perpendicular to picture plane.

Conversion of Pictorial Views: Conversion of pictorial views into orthographic views.

### SECTION B

*(To be conducted in CAD Lab)*

Introduction to Computer Aided Drawing: Role of CAD in design and development of new products, Advantages of CAD. Creating two dimensional drawing with dimensions using suitable software. (Minimum 2 exercises mandatory)

Introduction to Solid Modelling: Creating 3D models of various components using suitable modelling software. (Minimum 2 exercises mandatory)

**Text Books**

1. Bhatt, N.D., Engineering Drawing, Charotar Publishing House Pvt. Ltd.
2. John, K.C. Engineering Graphics, Prentice Hall India Publishers.

**Reference Books**

1. Anilkumar, K.N., Engineering Graphics, Adhyuth narayan Publishers
2. Agrawal, B. And Agrawal, C.M., Engineering Drawing, Tata McGraw Hill Publishers.
3. Benjamin, J., Engineering Graphics, Pentex Publishers- 3<sup>rd</sup> Edition, 2017
4. Duff, J.M. and Ross, W.A., Engineering Design and Visualisation, Cengage Learning.
5. Kulkarni, D.M., Rastogi, A.P. and Sarkar, A.K., Engineering Graphics with AutoCAD, PHI.
6. Luzaddff, W.J. and Duff, J.M., Fundamentals of Engineering Drawing, PHI.
7. Varghese, P.I., Engineering Graphics, V I P Publishers
8. Venugopal, K., Engineering Drawing and Graphics, New Age International Publishers.

**Course Contents and Lecture Schedule**

No	SECTION A	No. of Hours
1	<b>MODULE I</b>	
1.1	Introduction to graphics, types of lines, Dimensioning	1
1.2	Concept of principle planes of projection, different quadrants, locating points on different quadrants	2
1.3	Projection of lines, inclined to one plane. Lines inclined to both planes, trapezoid method of solving problems on lines.	2
1.4	Problems on lines using trapezoid method	2
1.5	Line rotation method of solving, problems on line rotation method	2
2	<b>MODULE II</b>	
2.1	Introduction of different solids, Simple position plan and elevation of solids	2
2.2	Problems on views of solids inclined to one plane	2
2.3	Problems on views of solids inclined to both planes	2
2.4	Practice problems on solids inclined to both planes	2

3	<b>MODULE III</b>	
3.1	Introduction to section planes. AIP and AVP. Principle of locating cutting points and finding true shape	2
3.2	Problems on sections of different solids	2
3.3	Problems when the true shape is given	2
3.4	Principle of development of solids, sectioned solids	2
4	<b>MODULE IV</b>	
4.1	Principle of Isometric View and Projection, Isometric Scale. Problems on simple solids	2
4.2	Isometric problems on Frustum of solids, Sphere and Hemisphere	2
4.3	Problems on combination of different solids	2
5	<b>MODULE V</b>	
5.1	Introduction to perspective projection, different planes, station point etc. Perspective problems on pyramids	2
5.2	Perspective problems on prisms	2
5.3	Practice on conversion of pictorial views into orthographic views	2
	<b>SECTION B</b> <i>(To be conducted in CAD lab)</i>	
1	Introduction to CAD and software. Familiarising features of 2D software. Practice on making 2D drawings	2
2	Practice session on 2D drafting	2
3	Introduction to solid modelling and software	2
4	Practice session on 3D modelling	2

COURSE CODE	COURSE NAME	CATEGORY	L	T	P	CREDITS
22EST106	BASICS OF CIVIL & MECHANICAL ENGINEERING	ES	4	0	0	4

**Preamble:**

Objective of this course is to provide an insight and inculcate the essentials of Civil Engineering discipline to the students of all branches of Engineering and to provide the students an illustration of the significance of the Civil Engineering Profession in satisfying the societal needs.

To introduce the students to the basic principles of mechanical engineering

**Prerequisite:** NIL

**Course Outcomes:** After completion of the course, the student will be able to

<b>CO 1</b>	Recall the role of civil engineer in society and to relate the various disciplines of Civil Engineering.
<b>CO 2</b>	Explain different types of buildings, building components, building materials and building construction
<b>CO 3</b>	Describe the importance, objectives and principles of surveying.
<b>CO 4</b>	Summarise the basic infrastructure services MEP, HVAC, elevators, escalators and ramps
<b>CO 5</b>	Discuss the Materials, energy systems, water management and environment for green buildings.
<b>CO 6</b>	Analyse thermodynamic cycles and calculate its efficiency
<b>CO 7</b>	Illustrate the working and features of IC Engines
<b>CO 8</b>	Explain the basic principles of Refrigeration and Air Conditioning
<b>CO 9</b>	Describe the working of hydraulic machines
<b>CO 10</b>	Explain the working of power transmission elements
<b>CO 11</b>	Describe the basic manufacturing, metal joining and machining processes

**Mapping of course outcomes with program outcomes**

	PO 1	PO 2	PO 3	PO 4	PO 5	PO 6	PO 7	PO 8	PO 9	PO 10	PO 11	PO 12
<b>CO1</b>	3	-	-	-	-	3	2	2	-	-	-	-
<b>CO2</b>	3	2	-	1	3	-	-	3	-	-	-	-
<b>CO3</b>	3	2	-	-	3	-	-	-	2	-	-	-

CO4	3	2	-	-	3	-	-	-	2	-	-	-
CO5	3	2	-	-	3	2	3	-	2	-	-	-
CO6	3	2										
CO7	3	1										
CO8	3	1										
CO9	3	2										
CO10	3	1										
CO11	3											

### Assessment Pattern

Bloom's Category	Basic Civil Engineering			Basic Mechanical Engineering		
	Continuous Assessment		End Semester Examination (marks)	Continuous Assessment		End Semester Examination (marks)
	Test 1 marks	Test 2 marks		Test 1 marks	Test 2 marks	
Remember	5	5	10	7.5	7.5	15
Understand	20	20	40	12.5	12.5	25
Apply				5	5	10
Analyse						
Evaluate						
Create						

### Mark distribution

Total Marks	CIE (Marks)	ESE (Marks)	ESE Duration
150	50	100	3 hours

### Continuous Internal Evaluation Pattern:

Attendance	: 10 marks
Continuous Assessment Test (2 numbers)	: 25 marks
Assignment/Quiz/Course project	: 15 marks

### End Semester Examination Pattern:

There will be two parts; Part I – Basic Civil Engineering and Part II – Basic Mechanical Engineering. Part I and PART II carries 50 marks each. For the end semester examination, part I contain 2 parts -



Part A and Part B. Part A contain 5 questions carrying 4 marks each (not exceeding 2 questions from each module). Part B contains 2 questions from each module out of which one to be answered. Each question carries 10 mark and can have maximum 2 sub-divisions. The pattern for end semester examination for part II is same as that of part I. **However, student should answer both part I and part 2 in separate answer booklets.**

**Course Level Assessment Questions:**

**Course Outcome CO1:** *To recall the role of civil engineer in society and to relate the various disciplines of Civil Engineering.*

1.Explain relevance of Civil engineering in the overall infrastructural development of the country.  
Course outcome 2 (CO2) (One question from each module and not more than two)

*Explain different types of buildings, building components, building materials and building construction*

1. Discuss the difference between plinth area and carpet area.

Course outcome 3 (CO3) (One question from each module and not more than two)

*Describe the importance, objectives and principles of surveying.*

1. Explain the importance of surveying in Civil Engineering

Course outcome 4 (CO4) (One question from each module and not more than two)

*Summarise the basic infrastructure services MEP, HVAC, elevators, escalators and ramps*

1. Explain the civil engineering aspects of elevators, escalators and ramps in buildings

Course outcome 5 (CO5) (One question from each module and not more than two)

*Discuss the Materials, energy systems, water management and environment for green buildings.*

1. Discuss the relevance of Green building in society

**Section II** *Answer any 1 full question from each module. Each full question carries 10 marks*

**Course Outcome 1 (CO1)** (Two full question from each module and each question can have maximum 2 sub-divisions)

*To recall the role of civil engineer in society and to relate the various disciplines of Civil Engineering*

**CO Questions**

1. **a** List out the types of building as per occupancy. Explain any two, each in about five sentences.  
**b.** Discuss the components of a building with a neat figure.
2. **a.** What are the major disciplines of civil engineering and explain their role in the infrastructural framework.

b. Explain the role of NBC, KBR & CRZ norms in building rules and regulations prevailing in our country.

**Course Outcome 2 (CO2) & Course Outcome 3 (CO3) (Two full question from each module and each question can have maximum 2 sub-divisions)**

*Explain different types of buildings, building components, building materials and building construction & Describe the importance, objectives and principles of surveying.*

**CO Questions**

1. a. What are the different kinds of cement available and what is their use.  
b. List the properties of good building bricks. Explain any five.
2. a. List and explain any five modern construction materials used for construction.  
b. Explain the objectives and principles of surveying

**Course outcome 4 (CO4) & Course outcome 5 (CO5) (Two full question from each module and each question can have maximum 2 sub-divisions)**

*Summarise the basic infrastructure services MEP, HVAC, elevators, escalators and ramps & Discuss the Materials, energy systems, water management and environment for green buildings.*

**CO Questions**

1. a. Draw the elevation and plan of one brick thick wall with English bond  
b. Explain the energy systems and water management in Green buildings
  
2. a. Draw neat sketch of the following foundations: (i) Isolated stepped footing;  
(ii) Cantilever footing; and (iii) Continuous footing.  
  
b. Discuss the civil engineering aspect of MEP and HVAC in a commercial building

**Course Outcome 6 (CO6):**

1. In an air standard Otto cycle the compression ratio is 7 and compression begins at 35°C, 0.1 MPa. The maximum temperature of the cycle is 1100°C. Find
  - i) Heat supplied per kg of air,
  - ii) Work done per kg of air,
  - iii) Cycle efficiencyTake  $C_p = 1.005 \text{ kJ/kgK}$  and  $C_v = 0.718 \text{ kJ/kgK}$
2. A Carnot cycle works with adiabatic compression ratio of 5 and isothermal expansion ratio of 2. The volume of air at the beginning of isothermal expansion is  $0.3 \text{ m}^3$ . If the maximum temperature and pressure is limited to 550K and 21 bar, determine the minimum temperature in the cycle and efficiency of the cycle.
3. In an ideal diesel cycle, the temperature at the beginning and end of compression is 65°C and 620°C respectively. The temperature at the beginning and end of the expansion is 1850°C and 850°C. Determine the ideal efficiency of the cycle.

4. Explain the concepts of CRDI and MPFI in IC Engines.

**Course Outcome 7 (CO7)**

1. With the help of a neat sketch explain the working of a 4 stroke SI engine
2. Compare the working of 2 stroke and 4 stroke IC engines
3. Explain the classification of IC Engines.

**Course Outcome 8(CO8):**

1. Explain the working of vapour compression refrigeration system.
2. With the help of suitable sketch explain the working of a split air conditioner.
3. Define: COP, specific humidity, relative humidity and dew point temperature.

**Course Outcome 9 (CO9):**

1. Explain the working of a single stage centrifugal pump with sketches.
2. With the help of a neat sketch, explain the working of a reciprocating pump.
3. A turbine is to operate under a head of 25 m at 200 rpm. The discharge is  $9 \text{ m}^3/\text{s}$ . If the overall efficiency of the turbine is 90%. Determine the power developed by the turbine.

**Course Outcome 10 (CO10):**

1. Explain the working of belt drive and gear drive with the help of neat sketches
2. Explain a single plate clutch.
3. Sketch different types of gear trains and explain.

**Course Outcome 11 (CO11):**

1. Describe the operations which can be performed using drilling machine.
2. Explain the functions of runners and risers used in casting.
3. With a neat sketch, explain the working and parts of a lathe.

**Model Question Paper**

**QP CODE: EST120**

page:3

Reg No: \_\_\_\_\_

Name: \_\_\_\_\_

**APJ ABDUL KALAM TECHNOLOGICAL UNIVERSITY FIRST SEMESTER B.TECH DEGREE EXAMINATION,  
MONTH & YEAR**

**Course Code: EST 120**

**Course Name: BASICS OF CIVIL AND MECHANICAL ENGINEERING**

Max. Marks: 100

Duration: 3 hours

**Answer both part I and part 2 in separate answer booklets**

**PART I: BASIC CIVIL ENGINEERING**

**PART A**

(Answer all questions. Each question carries 4 marks)

1. Explain relevance of Civil engineering in the overall infrastructural development of the country.
2. Discuss the difference between plinth area and carpet area.
3. Explain different types of steel with their properties.
4. What are the different kinds of cement available and what is their use?
5. Define bearing capacity of soil.

(5 x 4 = 20)

**Part B**

Answer one full question from each module.

**MODULE I**

- 6a. List out the types of building as per occupancy. Explain any two, each in about five sentences. (5)
- b. Discuss the components of a building with a neat figure. (5)

**OR**

- 7a. What are the major disciplines of civil engineering and explain their role in the infrastructural framework. (5)
- b. Explain the role of NBC, KBR & CRZ norms in building rules and regulations prevailing in our country. (5)

**MODULE II**

- 8a. What are the different kinds of cement available and what is their use. (5)
- b. List the properties of good building bricks. Explain any five. (5)

**OR**

- 9a. List and explain any five modern construction materials used for construction. (5)
- b. Explain the objectives and principles of surveying (5)

**MODULE III**

- 10a. Draw the elevation and plan of one brick thick wall with English bond (5)
- b. Explain the energy systems and water management in Green buildings (5)

**OR**

- 11a. Draw neat sketch of the following foundations: (i) Isolated stepped footing; (ii) Cantilever footing; and (iii) Continuous footing. (5)
- b. Discuss the civil engineering aspect of MEP and HVAC in a commercial building (5)

[10 x 3 = 30]

## PART II: BASIC MECHANICAL ENGINEERING

### PART A

Answer all questions. Each question carries 4 marks

1. Sketch the P-v and T-s diagram of a Carnot cycle and List the processes.
2. Illustrate the working of an epicyclic gear train.
3. Explain cooling and dehumidification processes.
4. Differentiate between soldering and brazing.
5. Explain the principle of Additive manufacturing.

4 x 5 = 20 marks

### Part B

Answer one full question from each module.

#### MODULE I

6. In an air standard Otto cycle the compression ratio is 7 and compression begins at 35°C, 0.1MPa. The maximum temperature of the cycle is 1100°C. Find
  - i) Heat supplied per kg of air,
  - ii) Work done per kg of air,
  - iii) Cycle efficiency

Take  $C_p = 1.005 \text{ kJ/kgK}$  and  $C_v = 0.718 \text{ kJ/kgK}$

10 marks

#### OR

7. a) Explain the working of a 4 stroke SI engine with neat sketches. 7 marks  
b) Explain the fuel system of a petrol engine. 3 marks

#### MODULE II

8. a) Explain the working of a vapour compression system with help of a block diagram. 7 marks  
b) Define: Specific humidity, relative humidity and dew point temperature. 3 marks

#### OR

9. With the help of a neat sketch, explain the working of a centrifugal pump. 10 marks

#### MODULE III

10. Explain the two high, three high, four high and cluster rolling mills with neat sketches. 10 marks

#### OR

11. a) Describe the arc welding process with a neat sketch. 6 marks  
b) Differentiate between up-milling and down-milling operations. 4 marks

## SYLLABUS

### Module 1

**General Introduction to Civil Engineering:** Relevance of Civil Engineering in the overall infrastructural development of the country. Responsibility of an engineer in ensuring the safety of built environment. Brief introduction to major disciplines of Civil Engineering like Transportation Engineering, Structural Engineering, Geo-technical Engineering, Water Resources Engineering and Environmental Engineering.

**Introduction to buildings:** Types of buildings, selection of site for buildings, components of a residential building and their functions.

**Building rules and regulations:** Relevance of NBC, KBR & CRZ norms (brief discussion only).

**Building area:** Plinth area, built up area, floor area, carpet area and floor area ratio for a building as per KBR.

### Module 2

**Surveying:** Importance, objectives and principles.

**Construction materials,** Conventional construction materials: types, properties and uses of building materials: bricks, stones, cement, sand and timber

**Cement concrete:** Constituent materials, properties and types.

Steel: Steel sections and steel reinforcements, types and uses.

**Modern construction materials:-** Architectural glass, ceramics, Plastics, composite materials, thermal and acoustic insulating materials, decorative panels, waterproofing materials. Modern uses of gypsum, pre-fabricated building components (brief discussion only).

### Module 3

**Building Construction:** Foundations: Bearing capacity of soil (definition only), functions of foundations, types – shallow and deep (brief discussion only). Load bearing and framed structures (concept only).

**Brick masonry:** - Header and stretcher bond, English bond & Flemish bond random rubble masonry.

**Roofs and floors:** - Functions, types; flooring materials (brief discussion only).

**Basic infrastructure services:** MEP, HVAC, elevators, escalators and ramps (Civil Engineering aspects only), fire safety for buildings.

**Green buildings:-** Materials, energy systems, water management and environment for green buildings. (brief discussion only).

### Module 4

**Analysis of thermodynamic cycles:** Carnot, Otto, Diesel cycles, Derivation of efficiency of these cycles, Problems to calculate heat added, heat rejected, net work and efficiency. IC Engines: CI, SI, 2-Stroke, 4-Stroke engines. Listing the parts of different types of IC Engines. Efficiencies of IC Engines(Definitions only), Air, Fuel, cooling and lubricating systems in SI and CI Engines, CRDI, MPFI. Concept of hybrid engines.

### Module 5

**Refrigeration:** Unit of refrigeration, reversed Carnot cycle, COP, vapour compression cycle (only description and no problems); Definitions of dry, wet & dew point temperatures, specific humidity and relative humidity, Cooling and dehumidification, Layout of unit and central air conditioners.

Description about working with sketches of: Reciprocating pump, Centrifugal pump, Pelton turbine, Francis turbine and Kaplan turbine. Overall efficiency, Problems on calculation of input and output power of pumps and turbines (No velocity triangles)

Description about working with sketches of: Belt and Chain drives, Gear and Gear trains, Single plate clutches.

### Module 6

**Manufacturing Process:** Basic description of the manufacturing processes – Sand Casting, Forging, Rolling, Extrusion and their applications.

Metal Joining Processes: List types of welding, Description with sketches of Arc Welding, Soldering and Brazing and their applications

Basic Machining operations: Turning, Drilling, Milling and Grinding.

Description about working with block diagram of: Lathe, Drilling machine, Milling machine, CNC Machine. Principle of CAD/CAM, Rapid and Additive manufacturing.

### Text Books:

1. Rangwala, S. C., Essentials of Civil Engineering, Charotar Publishing House
2. Mckay, W.B. and Mckay, J. K., Building Construction, Volumes 1 to 4, Pearson India Education Services

### References Books:

1. Chen W.F and Liew J Y R (Eds), The Civil Engineering Handbook. II Edition CRC Press (Taylor and Francis)
2. Chudley, R and Greeno R, Building construction handbook, Addison Wesley, Longman group, England
3. Chudley, R, Construction Technology, Vol. I to IV, Longman group, England Course Plan
4. Kandy A A, Elements of Civil Engineering, Charotar Publishing house
5. Mamlouk, M. S., and Zaniewski, J. P., Materials for Civil and Construction Engineering, Pearson Publishers
6. Rangwala S.C and Dalal K B Building Construction Charotar Publishing house
7. Clifford, M., Simmons, K. and Shipway, P., An Introduction to Mechanical Engineering Part I - CRC Press
8. Roy and Choudhary, Elements of Mechanical Engineering, Media Promoters & Publishers Pvt. Ltd., Mumbai.
9. Sawhney, G. S., Fundamentals of Mechanical Engineering, PHI
10. G Shanmugam, M S Palanichamy, Basic Civil and Mechanical Engineering, McGraw Hill Education; First edition, 2018
11. Benjamin, J., Basic Mechanical Engineering, Pentex Books, 9<sup>th</sup> Edition, 2018
12. Balachandran, P. Basic Mechanical Engineering, Owl Books

**Course Contents and Lecture Schedule:**

No	Topic	Course outcomes addressed	No. of Lectures
<b>1</b>	<b>Module I</b>		<b>Total: 7</b>
1.1	<i>General Introduction to Civil Engineering:</i> Relevance of Civil Engineering in the overall infrastructural development of the country. Responsibility of an engineer in ensuring the safety of built environment.	CO1	1
1.2	Brief introduction to major disciplines of Civil Engineering like Transportation Engineering, Structural Engineering, Geo-technical Engineering, Water Resources Engineering and Environmental Engineering.	CO1	2
1.3	<i>Introduction to buildings:</i> Types of buildings, selection of site for buildings, components of a residential building and their functions.	CO2	2
1.4	<i>Building rules and regulations:</i> Relevance of NBC, KBR & CRZ norms (brief discussion only)	CO2	1
1.5	<i>Building area:</i> Plinth area, built up area, floor area, carpet area and floor area ratio for a building as per KBR.	CO2	1
<b>2</b>	<b>Module 2</b>		<b>Total: 7</b>
2.1	<i>Surveying:</i> Importance, objectives and principles.	CO3	1
2.2	Bricks: - Classification, properties of good bricks, and tests on bricks	CO2	1
2.3	Stones: - <i>Qualities</i> of good stones, types of stones and their uses. Cement: - Good qualities of cement, types of cement and their uses.	CO2	1
2.4	Sand: - Classification, qualities of good sand and sieve analysis (basics only). Timber: - Characteristics, properties and uses.	CO2	1
2.5	Cement concrete: - Constituent materials, properties and types, Steel: - Steel sections and steel reinforcements, types and uses.	CO2	1



2.6	Modern construction materials: - Architectural glass, ceramics, plastics, composite materials, thermal and acoustic insulating materials, decorative panels, waterproofing materials, modern uses of gypsum, pre-fabricated building components (brief discussion only)	CO2	2
<b>3</b>	<b>Module 3</b>		<b>Total: 7</b>
3.1	Foundations: - Bearing capacity of soil (definition only), functions of foundations, types – shallow and deep (brief discussion only). Brick masonry: - Header and stretcher bond, English bond & Flemish bond– elevation and plan (one & one and a half brick wall only). Random rubble masonry.	CO2	2
3.2	Roofs: Functions, types; roofing materials (brief discussion only) Floors: Functions, types; flooring materials (brief discussion only)	CO2	2
3.3	<i>Basic infrastructure services:</i> MEP, HVAC, Elevators, escalators and ramps (Civil Engineering aspects only) fire safety for buildings	CO4	2
3.4	<i>Green buildings:-</i> Materials, energy systems, water management and environment for green buildings. (brief discussion only)	CO5	1
<b>4</b>	<b>MODULE 4</b>		
4.1	Analysis of thermodynamic cycles: Carnot, Otto, and Diesel cycle- Derivation of efficiency of these cycles, Problems to calculate heat added, heat rejected, net work and efficiency		4
4.2	IC Engines: CI, SI, 2-Stroke, 4-Stroke engines. Listing the parts of different types of IC Engines, efficiencies of IC Engines(Description only)		2
4.3	Air, Fuel, cooling and lubricating systems in SI and CI Engines, CRDI, MPFI. Concept of hybrid engines		2
<b>5</b>	<b>MODULE 5</b>		
5.1	Refrigeration: Unit of refrigeration, reversed Carnot cycle, COP, vapour compression cycle (only description and no problems)		1
5.2	Definitions of dry, wet & dew point temperatures, specific humidity and relative humidity, Cooling and dehumidification, Layout of unit and central air conditioners.		1

5.3	Description about working with sketches : Reciprocating pump, Centrifugal pump, Pelton turbine, Francis turbine and Kaplan turbine. Overall efficiency, Problems on calculation of input and output power of pumps and turbines (No velocity triangles)	4
5.4	Description about working with sketches of: Belt and Chain drives, Gear and Gear trains, Single plate clutches	3
6	<b>MODULE 6</b>	
6.1	Manufacturing Process: Basic description of the manufacturing processes – Sand Casting, Forging, Rolling, Extrusion and their applications.	2
6.2	Metal Joining Processes :List types of welding, Description with sketches of Arc Welding, Soldering and Brazing, and their applications	1
6.3	Basic Machining operations: Turning, Drilling, Milling and Grinding  Description about working with block diagrams of: Lathe, Drilling machine, Milling machine, CNC Machine	3
6.4	Principle of CAD/CAM, Rapid and Additive manufacturing	1

COURSE CODE	COURSE NAME	CATEGORY	L	T	P	CREDITS
22EST107	BASICS OF ELECTRICAL AND ELECTRONICS ENGINEERING	ES	4	0	0	4

**Preamble:**

This course aims to (1) equip the students with an understanding of the fundamental principles of electrical engineering (2) provide an overview of evolution of electronics, and introduce the working principle and examples of fundamental electronic devices and circuits (3) provide an overview of evolution of communication systems, and introduce the basic concepts in radio communication.

**Prerequisite:** Physics and Mathematics (Pre-university level)

**Course Outcomes:** After the completion of the course the student will be able to

<b>CO 1</b>	Apply fundamental concepts and circuit laws to solve simple DC electric circuits
<b>CO 2</b>	Develop and solve models of magnetic circuits
<b>CO 3</b>	Apply the fundamental laws of electrical engineering to solve simple ac circuits in steady state
<b>CO 4</b>	Describe working of a voltage amplifier
<b>CO 5</b>	Outline the principle of an electronic instrumentation system
<b>CO 6</b>	Explain the principle of radio and cellular communication

**Mapping of course outcomes with program outcomes**

	PO 1	PO 2	PO 3	PO 4	PO 5	PO 6	PO 7	PO 8	PO 9	PO 10	PO 11	PO 12
<b>CO 1</b>	3	1	-	-	-	-	-	-	-	-	-	2
<b>CO 2</b>	3	1	-	-	-	-	-	-	-	-	-	2
<b>CO 3</b>	3	1	-	-	-	-	-	-	-	-	-	2
<b>CO 4</b>	2	-	-	-	-	-	-	-	-	-	-	-
<b>CO 5</b>	2	-	-	-	-	-	-	-	-	-	-	2
<b>CO 6</b>	2	-	-	-	-	-	-	-	-	-	-	2

**Assessment Pattern**

Bloom's Category	Basic Electrical Engineering			Basic Electronics Engineering		
	Continuous Assessment Tests		End Semester Examination (Marks)	Continuous Assessment Tests		End Semester Examination (Marks)
	Test 1 (Marks)	Test 2 (Marks)		Test 1 (Marks)	Test 2 (Marks)	
Remember	0	0	10	10	10	20
Understand	12.5	12.5	20	15	15	30
Apply	12.5	12.5	20			
Analyse						
Evaluate						
Create						

### Mark distribution

Total Marks	CIE marks	ESE marks	ESE Duration
150	50	100	3 hours

#### Continuous Internal Evaluation Pattern:

Attendance	: 10 marks
Continuous Assessment Test (2 numbers)	: 25 marks
Assignment/Quiz/Course project	: 15 marks

**End Semester Examination Pattern:** There will be two parts; Part I – Basic Electrical Engineering and Part II – Basic Electronics Engineering. Part I and PART II carries 50 marks each. For the end semester examination, part I contain 2 parts - Part A and Part B. Part A contain 5 questions carrying 4 marks each (not exceeding 2 questions from each module). Part B contains 2 questions from each module out of which one to be answered. Each question carries 10 mark and can have maximum 2 sub-divisions. The pattern for end semester examination for part II is same as that of part I. **However, student should answer both part I and part 2 in separate answer booklets.**

#### Course Level Assessment Questions

##### Course Outcome 1 (CO1):

1. Solve problems based on current division rule.
2. Solve problems with Mesh/node analysis.
3. Solve problems on Wye-Delta Transformation.

##### Course Outcome 2 (CO2):

1. Problems on series magnetic circuits
2. Problems on parallel magnetic circuits
3. Problems on composite magnetic circuits

##### 4. Course Outcome 3 (CO3):

1. problems on self inductance, mutual inductance and coefficient of coupling
2. problems on rms and average values of periodic waveforms
3. problems on series ac circuits
4. Compare star and Delta connected 3 phase AC systems.

##### Course Outcome 4 (CO4): Describe working of a voltage amplifier

1. What is the need of voltage divider biasing in an RC coupled amplifier?

2. Define operating point in the context of a BJT amplifier.
3. Why is it required to have a voltage amplifier in a public address system?

**Course Outcome 5 (CO5):** Outline the principle of an electronic instrumentation system

1. Draw the block diagram of an electronic instrumentation system.
2. What is a transducer?
3. Explain the working principle of operation of digital multimeter.

**Course Outcome 6 (CO6):** Explain the principle of radio and cellular communication

1. What is the working principle of an antenna when used in a radio transmitter?
2. What is the need of two separate sections RF section and IF section in a super heterodyne receiver?
3. What is meant by a cell in a cellular communication?

### Model Question Paper

QP CODE:

Pages: 3

Reg No.: \_\_\_\_\_

Name: \_\_\_\_\_

**APJ ABDUL KALAM TECHNOLOGICAL UNIVERSITY FIRST SEMESTER B.TECH DEGREE EXAMINATION,  
MONTH & YEAR**

*Course Code: EST 130*

*Course Name: BASICS OF ELECTRICAL AND ELECTRONICS ENGINEERING*

Max. Marks: 100

Duration: 3 hours

**Answer both part I and part 2 in separate answer booklets**

#### PART I

#### BASIC ELECTRICAL ENGINEERING

#### PART A

*Answer all questions; each question carries 4 marks.*

1. Calculate the current through the  $4\ \Omega$  resistor in the circuit shown, applying current division rule:

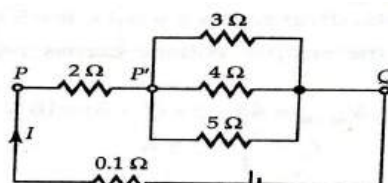

2. Calculate the RMS and average values of a purely sinusoidal current having peak value 15A.
3. An alternating voltage of  $(80+j60)V$  is applied to an RX circuit and the current flowing through the circuit is  $(-4+j10)A$ . Calculate the impedance of the circuit in rectangular and polar forms. Also determine if X is inductive or capacitive.
4. Derive the relation between line and phase values of voltage in a three phase star connected system.
5. Compare electric and magnetic circuits. (5x4=20)

**PART B**

*Answer one question from each module; each question carries 10 marks.*

**Module 1**

6. . Calculate the node voltages in the circuit shown, applying node analysis:

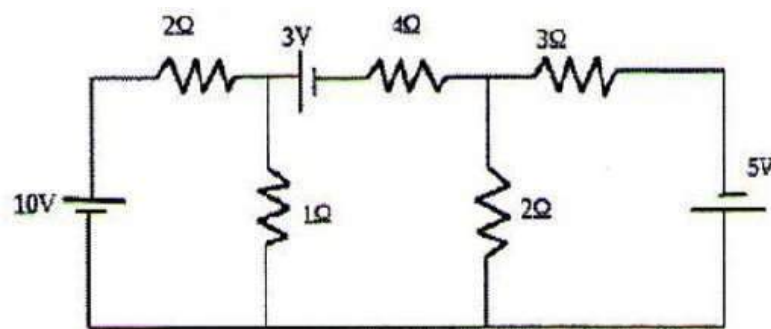

7. (a) State and explain Kirchhoff's laws. (4 marks)
- (b) Calculate the current through the galvanometer (G) in the circuit shown:

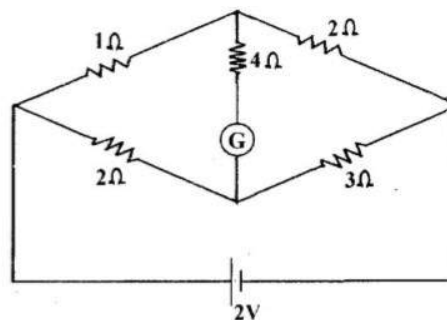

(6 marks)

### Module 2

8. (a) State and explain Faraday's laws of electromagnetic induction with examples. (4 marks)
- (b) Differentiate between statically and dynamically induced emf. A conductor of length 0.5m moves in a uniform magnetic field of flux density 1.1T at a velocity of 30m/s. Calculate the emf induced in the conductor if the direction of motion of the conductor is inclined at  $60^\circ$  to the direction of field. (6 marks)
9. (a) Derive the amplitude factor and form factor of a purely sinusoidal waveform. (5 marks)
- (b) A current wave is made up of two components-a 5A dc component and a 50Hz ac component, which is a sinusoidal wave with a peak value of 5A. Sketch the resultant waveform and determine its RMS and average values. (5 marks)

### Module 3

10. Draw the power triangle and define active, reactive and apparent powers in ac circuits. Two coils A and B are connected in series across a 240V, 50Hz supply. The resistance of A is  $5\Omega$  and the inductance of B is 0.015H. If the input from the supply is 3kW and 2kVAR, find the inductance of A and the resistance of B. Also calculate the voltage across each coil.
11. A balanced three phase load consists of three coils each having resistance of  $4\Omega$  and inductance 0.02H. It is connected to a 415V, 50Hz, 3-phase ac supply. Determine the phase voltage, phase current, power factor and active power when the loads are connected in (i) star (ii) delta.

(3x10=30)

### PART II

#### BASIC ELECTRONICS ENGINEERING

#### PART A

*Answer all questions; each question carries 4 marks.*

1. Give the specifications of a resistor. The colour bands marked on a resistor are Blue, Grey, Yellow and Gold. What are the minimum and maximum resistance values expected from that resistance?
2. What is meant by avalanche breakdown?
3. Explain the working of a full-wave bridge rectifier.
4. Discuss the role of coupling and bypass capacitors in a single stage RC coupled amplifier.
5. Differentiate AM and FM communication systems.

(5x4=20)

**PART B**

***Answer one question from each module; each question carries 10 marks.***

**Module 4**

6. a) Explain with diagram the principle of operation of an NPN transistor. (5)  
b) Sketch and explain the typical input-output characteristics of a BJT when connected in common emitter configuration. (5)

**OR**

7. a) Explain the formation of a potential barrier in a P-N junction diode. (5)  
b) What do you understand by Avalanche breakdown? Draw and explain the V-I characteristics of a P-N junction and Zener diode. (5)

**Module 5**

8. a) With a neat circuit diagram, explain the working of an RC coupled amplifier. (6)  
b) Draw the frequency response characteristics of an RC coupled amplifier and state the reasons for the reduction of gain at lower and higher frequencies. (4)

**OR**

9. a) With the help of block diagram, explain how an electronic instrumentation system. (6)  
b) Explain the principle of an antenna. (4)

**Module 6**

10. a) With the help of a block diagram, explain the working of Super heterodyne receiver. (6)  
b) Explain the importance of antenna in a communication system. (4)

**OR**

11. a) With neat sketches explain a cellular communication system. (5)  
b) Explain GSM communication with the help of a block diagram. (5)

*(3x10=30)*



## SYLLABUS

### MODULE 1: Elementary Concepts of Electric Circuits

**Elementary concepts of DC electric circuits:** Basic Terminology including voltage, current, power, resistance, emf; Resistances in series and parallel; Current and Voltage Division Rules; Capacitors & Inductors: V-I relations and energy stored. Ohms Law and Kirchhoff's laws-Problems; Star-delta conversion (resistive networks only-derivation not required)-problems.

**Analysis of DC electric circuits:** Mesh current method - Matrix representation - Solution of network equations. Node voltage methods-matrix representation-solution of network equations by matrix methods. Numerical problems.

### MODULE 2: Elementary Concepts of Magnetic circuits, Electromagnetic Induction and AC fundamentals

**Magnetic Circuits:** Basic Terminology: MMF, field strength, flux density, reluctance - comparison between electric and magnetic circuits- Series and parallel magnetic circuits with composite materials, numerical problems.

**Electromagnetic Induction:** Faraday's laws, problems, Lenz's law- statically induced and dynamically induced emfs - Self-inductance and mutual inductance, coefficient of coupling

**Alternating Current fundamentals:** Generation of alternating voltages-Representation of sinusoidal waveforms: frequency, period, Average, RMS values and form factor of waveforms-Numerical Problems.

### MODULE 3: AC Circuits

**AC Circuits:** Phasor representation of sinusoidal quantities. Trigonometric, Rectangular, Polar and complex forms. Analysis of simple AC circuits: Purely resistive, inductive & capacitive circuits; Inductive and capacitive reactance, concept of impedance. Average Power Power factor. Analysis of RL, RC and RLC series circuits-active, reactive and apparent power. Simple numerical problems.

**Three phase AC systems:** Generation of three phase voltages; advantages of three phase systems, star and delta connections (balanced only), relation between line and phase voltages, line and phase currents- Numerical problems

### MODULE 4

**Introduction to Semiconductor devices:** Evolution of electronics – Vacuum tubes to nano electronics. Resistors, Capacitors and Inductors (constructional features not required): types, specifications. Standard values, color coding. PN Junction diode: Principle of operation, V-I characteristics, principle of avalanche breakdown. Bipolar Junction Transistors: PNP and NPN structures, Principle of operation, relation between current gains in CE, CB and CC, input and output characteristics of common emitter configuration.

## MODULE 5

**Basic electronic circuits and instrumentation:** Rectifiers and power supplies: Block diagram description of a dc power supply, Working of a full wave bridge rectifier, capacitor filter (no analysis), working of simple zener voltage regulator. Amplifiers: Block diagram of Public Address system, Circuit diagram and working of common emitter (RC coupled) amplifier with its frequency response, Concept of voltage divider biasing. Electronic Instrumentation: Block diagram of an electronic instrumentation system.

## MODULE 6

**Introduction to Communication Systems:** Evolution of communication systems – Telegraphy to 5G. Radio communication: principle of AM & FM, frequency bands used for various communication systems, block diagram of super heterodyne receiver, Principle of antenna – radiation from accelerated charge. Mobile communication: basic principles of cellular communications, principle and block diagram of GSM.

### Text Books

1. D P Kothari and I J Nagrath, "Basic Electrical Engineering", Tata McGraw Hill, 2010.
2. D C Kulshreshtha, "Basic Electrical Engineering", Tata McGraw Hill, 2010.
3. ChinmoySaha, Arindham Halder and Debarati Ganguly, Basic Electronics - Principles and Applications, Cambridge University Press, 2018.
4. M.S.Sukhija and T.K.Nagsarkar, Basic Electrical and Electronics Engineering, Oxford University Press, 2012.
5. Wayne Tomasi and Neil Storey, A Textbook On Basic Communication and Information Engineering, Pearson, 2010.

### Reference Books

1. Del Toro V, "Electrical Engineering Fundamentals", Pearson Education.
2. T. K. Nagsarkar, M. S. Sukhija, "Basic Electrical Engineering", Oxford Higher Education.
3. Hayt W H, Kemmerly J E, and Durbin S M, "Engineering Circuit Analysis", Tata McGraw-Hill
4. Hughes, "Electrical and Electronic Technology", Pearson Education.
5. V. N. Mittle and Arvind Mittal, "Basic Electrical Engineering," Second Edition, McGraw Hill.
6. Parker and Smith, "Problems in Electrical Engineering", CBS Publishers and Distributors.
7. S. B. Lal Seksena and Kaustuv Dasgupta, "Fundamentals of Electrical Engineering", Cambridge University Press.
8. Anant Agarwal, Jeffrey Lang, Foundations of Analog and Digital Electronic Circuits, Morgan Kaufmann Publishers, 2005.
9. Bernard Grob, Basic Electronics, McGraw Hill.
10. A. Bruce Carlson, Paul B. Crilly, Communication Systems: An Introduction to Signals and Noise in Electrical Communication, Tata McGraw Hill, 5<sup>th</sup> Edition.

## COURSE CONTENTS AND LECTURE SCHEDULE

No	Topic	No. of Lectures
<b>1</b>	<b><i>Elementary Concepts of Electric Circuits</i></b>	
1.1	<p><b>Elementary concepts of DC electric circuits:</b></p> <p>Basic Terminology including voltage, current, power, resistance, emf; Resistances in series and parallel; Current and Voltage Division Rules; Capacitors &amp; Inductors: V-I relations and energy stored.</p> <p>Ohms Law and Kirchhoff's laws-Problems;</p> <p>Star-delta conversion (resistive networks only-derivation not required)-problems.</p>	<p>1</p> <p>2</p> <p>1</p>
1.2	<p><b>Analysis of DC electric circuits:</b> Mesh current method - Matrix representation - Solution of network equations.</p> <p>Node voltage methods-matrix representation-solution of network equations by matrix methods.</p> <p>Numerical problems.</p>	<p>1</p> <p>1</p> <p>2</p>
<b>2</b>	<b>Elementary Concepts of Magnetic circuits, Electromagnetic Induction and AC fundamentals</b>	
2.1	<p><b>Magnetic Circuits:</b> Basic Terminology: MMF, field strength, flux density, reluctance - comparison between electric and magnetic circuits-</p> <p>Series and parallel magnetic circuits with composite materials, numerical problems.</p>	<p>1</p> <p>2</p>
2.2	<p><b>Electromagnetic Induction:</b> Faraday's laws, problems, Lenz's law- statically induced and dynamically induced emfs -</p> <p>Self-inductance and mutual inductance, coefficient of coupling</p>	<p>1</p> <p>2</p>
2.3	<p><b>Alternating Current fundamentals:</b> Generation of alternating voltages- Representation of sinusoidal waveforms: frequency, period, Average, RMS values and form factor of waveforms-Numerical Problems.</p>	2
<b>3</b>	<b>AC Circuits</b>	

3.1	<p><b>AC Circuits:</b> Phasor representation of sinusoidal quantities. Trigonometric, Rectangular, Polar and complex forms.</p> <p>Analysis of simple AC circuits: Purely resistive, inductive &amp; capacitive circuits; Inductive and capacitive reactance, concept of impedance. Average Power, Power factor.</p> <p>Analysis of RL, RC and RLC series circuits-active, reactive and apparent power.</p> <p>Simple numerical problems.</p>	1 2 1 2
3.2	<p><b>Three phase AC systems:</b> Generation of three phase voltages; advantages of three phase systems, star and delta connections (balanced only), relation between line and phase voltages, line and phase currents- Numerical problems.</p>	2
<b>4</b>	<b>Introduction to Semiconductor devices</b>	
4.1	Evolution of electronics – Vacuum tubes to nano electronics (In evolutionary perspective only)	1
4.2	Resistors, Capacitors and Inductors: types, specifications. Standard values, color coding (No constructional features)	2
4.3	<b>PN Junction diode:</b> Principle of operation, V-I characteristics, principle of avalanche breakdown	2
4.4	<b>Bipolar Junction Transistors:</b> PNP and NPN structures, Principle of operation, relation between current gains in CE, CB and CC, input and output characteristics of common emitter configuration	3
<b>5</b>	<b>Basic electronic circuits and instrumentation</b>	
5.1	<b>Rectifiers and power supplies:</b> Block diagram description of a dc power supply, Working of a full wave bridge rectifier, capacitor filter (no analysis), working of simple zener voltage regulator	3
5.2	<b>Amplifiers:</b> Block diagram of Public Address system, Circuit diagram and working of common emitter (RC coupled) amplifier with its frequency response, Concept of voltage divider biasing	4
5.3	<b>Electronic Instrumentation:</b> Block diagram of an electronic instrumentation system	2
<b>6</b>	<b>Introduction to Communication Systems</b>	
6.1	Evolution of communication systems – Telegraphy to 5G	1

6.2	<b>Radio communication:</b> principle of AM & FM, frequency bands used for various communication systems, block diagram of super heterodyne receiver, Principle of antenna – radiation from accelerated charge	4
6.3	<b>Mobile communication:</b> basic principles of cellular communications, principle and block diagram of GSM.	2

#### **Suggested Simulation Assignments for Basic Electronics Engineering**

1. Plot V-I characteristics of Si and Ge diodes on a simulator
2. Plot Input and Output characteristics of BJT on a simulator
3. Implementation of half wave and full wave rectifiers
4. Simulation of RC coupled amplifier with the design supplied
5. Generation of AM signal

Note: The simulations can be done on open tools such as QUCS, KiCad, GNURadio or similar software to augment the understanding.

COURSE CODE	COURSE NAME	CATEGORY	L	T	P	CREDITS
22MNC108	LIFE SKILLS	MNC	2	0	2	-

**Preamble:** Life skills are those competencies that provide the means for an individual to be resourceful and positive while taking on life's vicissitudes. Development of one's personality by being aware of the self, connecting with others, reflecting on the abstract and the concrete, leading and generating change, and staying rooted in time-tested values and principles is being aimed at. This course is designed to enhance the employability and maximize the potential of the students by introducing them to the principles that underly personal and professional success, and help them acquire the skills needed to apply these principles in their lives and careers.

**Prerequisite:** None

**Course Outcomes:** After the completion of the course the student will be able to

<b>CO 1</b>	Define and Identify different life skills required in personal and professional life
<b>CO 2</b>	Develop an awareness of the self and apply well-defined techniques to cope with emotions and stress.
<b>CO 3</b>	Explain the basic mechanics of effective communication and demonstrate these through presentations.
<b>CO 4</b>	Take part in group discussions
<b>CO 5</b>	Use appropriate thinking and problem solving techniques to solve new problems
<b>CO 6</b>	Understand the basics of teamwork and leadership

#### Mapping of course outcomes with program outcomes

	PO 1	PO 2	PO 3	PO 4	PO 5	PO 6	PO 7	PO 8	PO 9	PO 10	PO 11	PO 12
<b>CO 1</b>						2		1	2	2	1	3
<b>CO 2</b>									3			2
<b>CO 3</b>						1			1	3		
<b>CO 4</b>										3		1
<b>CO 5</b>		3	2	1								
<b>CO 6</b>						1			3			

#### Mark distribution

Total Marks	CIE	ESE	ESE Duration
100	50	50	2 hours

## **Continuous Internal Evaluation**

**Total Marks: 50**

Attendance	: 10 marks
Regular assessment	: 15 marks
Series test (one test only, should include first three modules)	: 25 marks

### **Regular assessment**

➤ **Group Discussion (Marks: 9)**

Create groups of about 6 students each and engage them on a GD on a suitable topic for about 20 minutes. Parameters to be used for evaluation are as follows:

- Communication Skills : 3 marks
- Subject Clarity : 2 marks
- Group Dynamics : 2 marks
- Behaviours & Mannerisms : 2 marks

➤ **Presentation Skills (Marks: 6)**

Identify a suitable topic and ask the students to prepare a presentation (preferably a power point presentation) for about 10 minutes. Parameters to be used for evaluation are as follows:

- Communication Skills : 2 marks
- Platform Skills : 2 marks
- Subject Clarity/Knowledge : 2 marks

### **End Semester Examination**

**Total Marks: 50**

**Time: 2 hrs.**

#### **Part A: Short answer question (25 marks)**

There will be one question from each MODULE (five questions in total, five marks each). Each question should be written in about maximum of 400 words. Parameters to be used for evaluation are as follows:

- (i) Content Clarity/Subject Knowledge
- (ii) Presentation style
- (iii) Organization of content

#### **Part B: Case Study (25 marks)**

The students will be given a case study with questions at the end. The students have to analyze the case and answer the question at the end. Parameters to be used for evaluation are as follows:

- (i) Analyze the case situation
- (ii) Key players/characters of the case
- (iii) Identification of the problem (both major & minor if exists)
- (iv) Bring out alternatives
- (v) Analyze each alternative against the problem
- (vi) Choose the best alternative
- (vii) Implement as solution
- (viii) Conclusion

(ix) Answer the question at the end of the case

### **Course Level Assessment Questions**

#### **Course Outcome 1 (CO1):**

1. List 'life skills' as identified by WHO
2. What do you mean by effective communication?
3. What are the essential life skills required by a professional?

#### **Course Outcome 2 (CO2)**

1. Identify an effective means to deal with workplace stress.
2. How can a student apply journaling to stress management?
3. What is the PATH method? Describe a situation where this method can be used effectively.

#### **Course Outcome 3(CO3):**

1. Identify the communication network structure that can be observed in the given situations. Describe them.
  - (a) A group discussion on development.
  - (b) An address from the Principal regarding punctuality.
  - (c) A reporter interviewing a movie star.
  - (d) Discussing the answers of a test with a group of friends.
2. Elucidate the importance of non-verbal communication in making a presentation
3. Differentiate between kinesics, proxemics, and chronemics with examples.

#### **Course Outcome 4 (CO4):**

1. How can a participant conclude a group discussion effectively?
2. 'Listening skills are essential for effectively participating in a group discussion.' Do you agree? Substantiate your answer.

#### **Course Outcome 5 (CO5):**

1. Illustrate the creative thinking process with the help of a suitable example
2. Translate the following problem from verbal to graphic form and find the solution : *In a quiz, Ananth has 50 points more than Bimal, Chinmay has 60 points less than Ananth, and Dharini is 20 points ahead of Chinmay. What is the difference in points between Bimal and Dharini?*



3. List at least five ways in which the problem "How to increase profit?" can be redefined

**Course Outcome 6 (CO6):**

1. A group of engineers decided to brainstorm a design issue on a new product. Since no one wanted to disagree with the senior members, new ideas were not flowing freely. What group dynamics technique would you suggest to avoid this 'groupthink'? Explain the procedure.
2. "A group focuses on individual contribution, while a team must focus on synergy." Explain.
3. Identify the type of group formed / constituted in each of the given situations
  - a) A Police Inspector with subordinates reporting to him
  - b) An enquiry committee constituted to investigate a specific incident
  - c) The Accounts Department of a company
  - d) A group of book lovers who meet to talk about reading

**Syllabus**

**Module 1**

Overview of Life Skills: Meaning and significance of life skills, Life skills identified by WHO: Self-awareness, Empathy, Critical thinking, Creative thinking, Decision making, problem solving, Effective communication, interpersonal relationship, coping with stress, coping with emotion.

Life skills for professionals: positive thinking, right attitude, attention to detail, having the big picture, learning skills, research skills, perseverance, setting goals and achieving them, helping others, leadership, motivation, self-motivation, and motivating others, personality development, IQ, EQ, and SQ

**Module 2**

Self-awareness: definition, need for self-awareness; Coping With Stress and Emotions, Human Values, tools and techniques of SA: questionnaires, journaling, reflective questions, meditation, mindfulness, psychometric tests, feedback.

Stress Management: Stress, reasons and effects, identifying stress, stress diaries, the four A's of stress management, techniques, Approaches: action-oriented, emotion-oriented, acceptance-oriented, resilience, Gratitude Training,

Coping with emotions: Identifying and managing emotions, harmful ways of dealing with emotions, PATH method and relaxation techniques.

Morals, Values and Ethics: Integrity, Civic Virtue, Respect for Others, Living Peacefully. Caring, Sharing, Honesty, Courage, Valuing Time, Time management, Co operation, Commitment, Empathy, Self-Confidence, Character, Spirituality, Avoiding Procrastination, Sense of Engineering Ethics.

### **Module 3**

21<sup>st</sup> century skills: Creativity, Critical Thinking, Collaboration, Problem Solving, Decision Making, Need for Creativity in the 21st century, Imagination, Intuition, Experience, Sources of Creativity, Lateral Thinking, Myths of creativity, Critical thinking Vs Creative thinking, Functions of Left Brain & Right brain, Convergent & Divergent Thinking, Critical reading & Multiple Intelligence.

Steps in problem solving: Problem Solving Techniques, Six Thinking Hats, Mind Mapping, Forced Connections. Analytical Thinking, Numeric, symbolic, and graphic reasoning. Scientific temperament and Logical thinking.

### **Module 4**

Group and Team Dynamics: Introduction to Groups: Composition, formation, Cycle, thinking, Clarifying expectations, Problem Solving, Consensus, Dynamics techniques, Group vs Team, Team Dynamics, Virtual Teams. Managing team performance and managing conflicts, Intrapreneurship.

### **Module 5**

Leadership: Leadership framework, entrepreneurial and moral leadership, vision, cultural dimensions. Growing as a leader, turnaround leadership, managing diverse stakeholders, crisis management. Types of Leadership, Traits, Styles, VUCA Leadership, Levels of Leadership, Transactional vs Transformational Leaders, Leadership Grid, Effective Leaders.

## **Lab Activities**

### **Verbal**

Effective communication and Presentation skills.

Different kinds of communication; Flow of communication; Communication networks, Types of barriers; Miscommunication

Introduction to presentations and group discussions.

Learning styles: visual, aural, verbal, kinaesthetic, logical, social, solitary; Previewing, KWL table, active listening, REAP method

Note-taking skills: outlining, non-linear note-taking methods, Cornell notes, three column note taking.

Memory techniques: mnemonics, association, flashcards, keywords, outlines, spider diagrams and mind maps, spaced repetition.

Time management: auditing, identifying time wasters, managing distractions, calendars and checklists; Prioritizing - Goal setting, SMART goals; Productivity tools and apps, Pomodoro technique.

### **Non Verbal:**

Non-verbal Communication and Body Language: Forms of non-verbal communication; Interpreting body-language cues; Kinesics; Proxemics; Chronemics; Effective use of body language, Communication in a multi cultural environment.

### Reference Books

1. Shiv Khera, You Can Win, Macmillan Books, New York, 2003.
2. Barun K. Mitra, "Personality Development & Soft Skills", Oxford Publishers, Third impression, 2017.
3. ICT Academy of Kerala, "Life Skills for Engineers", McGraw Hill Education (India) Private Ltd., 2016.
4. Caruso, D. R. and Salovey P, "The Emotionally Intelligent Manager: How to Develop and Use the Four Key Emotional Skills of Leadership", John Wiley & Sons, 2004.
5. Kalyana, "Soft Skill for Managers"; First Edition; Wiley Publishing Ltd, 2015.
6. Larry James, "The First Book of Life Skills"; First Edition, Embassy Books, 2016.
7. Shalini Verma, "Development of Life Skills and Professional Practice"; First Edition; Sultan Chand (G/L) & Company, 2014.
8. Daniel Goleman, "Emotional Intelligence"; Bantam, 2006.
9. Remesh S., Vishnu R.G., "Life Skills for Engineers", Ridhima Publications, First Edition, 2016.
10. Butterfield Jeff, "Soft Skills for Everyone", Cengage Learning India Pvt Ltd; 1 edition, 2011.
11. Training in Interpersonal Skills: Tips for Managing People at Work, Pearson Education, India; 6 edition, 2015.
12. The Ace of Soft Skills: Attitude, Communication and Etiquette for Success, Pearson Education; 1 edition, 2013.

COURSE CODE	COURSE NAME	CATEGORY	L	T	P	CREDITS
22PHL109	ENGINEERING PHYSICS LAB	ES	0	0	2	1

**Preamble:** The aim of this course is to make the students gain practical knowledge to co-relate with the theoretical studies and to develop practical applications of engineering materials and use the principle in the right way to implement the modern technology.

**Prerequisite:** Higher secondary level Physics

**Course Outcomes:** After the completion of the course the student will be able to

<b>CO 1</b>	Develop analytical/experimental skills and impart prerequisite hands on experience for engineering laboratories
<b>CO 2</b>	Understand the need for precise measurement practices for data recording
<b>CO 3</b>	Understand the principle, concept, working and applications of relevant technologies and comparison of results with theoretical calculations
<b>CO 4</b>	Analyze the techniques and skills associated with modern scientific tools such as lasers and fiber optics
<b>CO 5</b>	Develop basic communication skills through working in groups in performing the laboratory experiments and by interpreting the results

#### Mapping of course outcomes with program outcomes

	PO 1	PO 2	PO 3	PO 4	PO 5	PO 6	PO 7	PO 8	PO 9	PO 10	PO 11	PO 12
<b>CO 1</b>	3				3			1	2			1
<b>CO 2</b>	3				3			1	2			1
<b>CO 3</b>	3				3			1	2			1
<b>CO 4</b>	3				3			1	2			1
<b>CO 5</b>	3				3			1	2			1

#### Mark distribution

Total Marks	CIE Marks	ESE Marks	ESE Duration(Internal)
100	100	-	1 hour

**Continuous Internal Evaluation Pattern:**

Attendance	: 20 marks
Class work/ Assessment /Viva-voce	: 50 marks
End semester examination (Internally by college)	: 30 marks

**End Semester Examination Pattern:** Written Objective Examination of one hour

**SYLLABUS****LIST OF EXPERIMENTS**

**(Minimum 8 experiments should be completed)**

1. CRO-Measurement of frequency and amplitude of wave forms
2. Measurement of strain using strain gauge and wheatstone bridge
3. LCR Circuit – Forced and damped harmonic oscillations
4. Melde’s string apparatus- Measurement of frequency in the transverse and longitudinal mode
5. Wave length measurement of a monochromatic source of light using Newton’s Rings method.
6. Determination of diameter of a thin wire or thickness of a thin strip of paper using air wedge method.
7. To measure the wavelength using a millimeter scale as a grating.
8. Measurement of wavelength of a source of light using grating.
9. Determination of dispersive power and resolving power of a plane transmission grating
10. Determination of the particle size of lycopodium powder
11. Determination of the wavelength of He-Ne laser or any standard laser using diffraction grating
12. Calculate the numerical aperture and study the losses that occur in optical fiber cable.
13. I-V characteristics of solar cell.
14. LED Characteristics.
15. Ultrasonic Diffractometer- Wavelength and velocity measurement of ultrasonic waves in a liquid
16. Deflection magnetometer-Moment of a magnet- Tan A position.

**Reference books**

1. S.L.Gupta and Dr.V.Kumar, “Practical physics with viva voice”, Pragati Prakashan Publishers, Revised Edition, 2009
2. M.N.Avadhanulu, A.A.Dani and Pokely P.M, “Experiments in Engineering Physics”, S.Chand&Co,2008
3. S. K. Gupta, “Engineering physics practicals”, Krishna Prakashan Pvt. Ltd., 2014
4. P. R. Sasikumar “Practical Physics”, PHI Ltd., 2011.

COURSE CODE	COURSE NAME	CATEGORY	L	T	P	CREDITS
22CYL110	ENGINEERING CHEMISTRY LAB	ES	0	0	2	1

**Preamble:** To impart scientific approach and to familiarize with the experiments in chemistry relevant for research projects in higher semesters

**Prerequisite:** Experiments in chemistry introduced at the plus two levels in schools

**Course outcomes:** After the completion of the course the students will be able to

<b>CO 1</b>	Understand and practice different techniques of quantitative chemical analysis to generate experimental skills and apply these skills to various analyses
<b>CO 2</b>	Develop skills relevant to synthesize organic polymers and acquire the practical skill to use TLC for the identification of drugs
<b>CO 3</b>	Develop the ability to understand and explain the use of modern spectroscopic techniques for analysing and interpreting the IR spectra and NMR spectra of some organic compounds
<b>CO 4</b>	Acquire the ability to understand, explain and use instrumental techniques for chemical analysis
<b>CO 5</b>	Learn to design and carry out scientific experiments as well as accurately record and analyze the results of such experiments
<b>CO 6</b>	Function as a member of a team, communicate effectively and engage in further learning. Also understand how chemistry addresses social, economical and environmental problems and why it is an integral part of curriculum

#### Mapping of course outcomes with program outcomes

	PO 1	PO 2	PO 3	PO 4	PO 5	PO 6	PO 7	PO 8	PO 9	PO 10	PO 11	PO 12
<b>CO 1</b>	3				2							3
<b>CO 2</b>	3				3							3
<b>CO 3</b>	3				3							3
<b>CO 4</b>	3				3							3
<b>CO 5</b>	3				1							3
<b>CO 6</b>	3				1							3

#### Mark distribution

Total Marks	CIE marks	ESE marks	ESE Duration(Internal)
100	100	-	1 hour



CO 7	2											
CO 8	2											

### Mark distribution

Total Marks	CIE	ESE	ESE Duration
100	70	30	1 hour

**Assessment Procedure:** Total marks allotted for the course is 100 marks. CIE shall be conducted for 70 marks and ESE for 30 marks. CIE should be done for the work done by the student and also viva voce based on the work done on each practical session. ESE shall be evaluated by written examination of one hour duration conducted internally by the institute.

### Continuous Internal Evaluation Pattern:

Attendance	: 20 marks
Class work/ Assessment /Viva-voce	: 50 marks
End semester examination (Internally by college)	: 30 marks

**End Semester Examination Pattern:** Written Objective Examination of one hour

## SYLLABUS

### PART 1

#### CIVIL WORKSHOP

- Exercise 1. Calculate the area of a built-up space and a small parcel of land- Use standard measuring tape and digital distance measuring devices
- Exercise 2. (a) Use screw gauge and vernier calliper to measure the diameter of a steel rod and thickness of a flat bar
- (b) Transfer the level from one point to another using a water level
- (c) Set out a one room building with a given plan and measuring tape
- Exercise 3. Find the level difference between any two points using dumpy level
- Exercise 4. (a) Construct a  $1\frac{1}{2}$  thick brick wall of 50 cm height and 60 cm length using English bond. Use spirit level to assess the tilt of walls.
- (b) Estimate the number of different types of building blocks to construct this wall.



Exercise 5. (a) Introduce the students to plumbing tools, different types of pipes, type of connections, traps, valves, fixtures and sanitary fittings.

(b) Install a small rainwater harvesting installation in the campus

**Reference Books:**

1. Khanna P.N, "Indian Practical Civil Engineering Handbook", Engineers Publishers.
2. Bhavikatti. S, "Surveying and Levelling (Volume 1)", I.K. International Publishing House
3. Arora S.P and Bindra S.P, " Building Construction", Dhanpat Rai Publications
4. S. C. Rangwala, "Engineering Materials," Charotar Publishing House.

**PART II**

**MECHANICAL WORKSHOP**

**LIST OF EXERCISES**

(Minimum EIGHT units mandatory and FIVE models from Units 2 to 8 mandatory)

UNIT 1:- General : Introduction to workshop practice, Safety precautions, Shop floor ethics, Basic First Aid knowledge.

Study of mechanical tools, components and their applications: (a) Tools: screw drivers, spanners, Allen keys, cutting pliers etc and accessories (b) bearings, seals, O-rings, circlips, keys etc.

UNIT 2:- Carpentry : Understanding of carpentry tools

Minimum any one model

1. T-Lap joint
2. Cross lap joint
3. Dovetail joint
4. Mortise joints

UNIT 3:- Foundry : Understanding of foundry tools

Minimum any one model

1. Bench Molding
2. Floor Molding
3. Core making
4. Pattern making

UNIT 4: - Sheet Metal : Understanding of sheet metal working tools

Minimum any one model

1. Cylindrical shape
2. Conical shape
3. Prismatic shaped job from sheet metal

UNIT 5: - Fitting : Understanding of tools used for fitting

Minimum any one model

1. Square Joint
2. V- Joint
3. Male and female fitting

UNIT 6: - Plumbing : Understanding of plumbing tools, pipe joints

Any one exercise on joining of pipes making use of minimum three types of pipe joints

UNIT 7: - Smithy: Understanding of tools used for smithy.

Demonstrating the forge-ability of different materials (MS, Al, alloy steel and cast steels) in cold and hot states.

Observing the qualitative difference in the hardness of these materials

Minimum any one exercise on smithy

1. Square prism
2. Hexagonal headed bolt
3. Hexagonal prism
4. Octagonal prism

UNIT 8: -Welding: Understanding of welding equipments

Minimum any one welding practice

Making Joints using electric arc welding. bead formation in horizontal, vertical and over head positions

UNIT 9: - Assembly: Demonstration only

Disassembling and assembling of

1. Cylinder and piston assembly
2. Tail stock assembly
3. Bicycle
4. Pump or any other machine

UNIT 10: - Machines: Demonstration and applications of the following machines

Shaping and slotting machine; Milling machine; Grinding Machine; Lathe; Drilling Machine.

UNIT 11: - Modern manufacturing methods: Power tools, CNC machine tools, 3D printing, Glass cutting.

**Course Contents and Lecture Schedule:**

No	Topic	No of Sessions
1	<b>INTRODUCTION</b>	
1.1	Workshop practice, shop floor precautions, ethics and First Aid knowledge. Studies of mechanical tools, components and their applications: (a) Tools: screw drivers, spanners, Allen keys, cutting pliers etc and accessories (b) bearings, seals, O-rings, circlips, keys etc	1
2	<b>CARPENTRY</b>	
2.1	Understanding of carpentry tools and making minimum one model	2

3	<b>FOUNDRY</b>	
3.1	Understanding of foundry tools and making minimum one model	2
4	<b>SHEET METAL</b>	
4.1	Understanding of sheet metal working tools and making minimum one model	2
5	<b>FITTING</b>	
5.1	Understanding of fitting tools and making minimum one model	2
6	<b>PLUMBING</b>	
6.1	Understanding of pipe joints and plumbing tools and making minimum one model	2
7	<b>SMITHY</b>	
7.1	Understanding of smithy tools and making minimum one model	2
8	<b>WELDING</b>	
8.1	Understanding of welding equipments and making minimum one model	2
9	<b>ASSEMBLY</b>	
9.1	Demonstration of assembly and disassembling of multiple parts components	1
10	<b>MACHINES</b>	
10.1	Demonstration of various machines	1
11	<b>MODERN MANUFACTURING METHODS</b>	
11.1	Demonstrations of: power tools, CNC Machine tools, 3D printing, Glass cutting	1

**Continuous Internal Evaluation Pattern:**

Attendance : 20 marks

Class work/ Assessment /Viva-voce : 50 marks

End semester examination (Internally by college) : 30 marks

**End Semester Examination Pattern:** Written Objective Examination of one hour

**SYLLABUS****LIST OF EXPERIMENTS (MINIMUM 8 MANDATORY)**

1. Estimation of total hardness of water-EDTA method
2. Potentiometric titration
3. Determination of cell constant and conductance of solutions.
4. Calibration of pH meter and determination of pH of a solution
5. Estimation of chloride in water
6. Identification of drugs using TLC
7. Determination of wavelength of absorption maximum and colorimetric estimation of  $\text{Fe}^{3+}$  in solution
8. Determination of molar absorptivity of a compound ( $\text{KMnO}_4$  or any water soluble food colorant)
9. Synthesis of polymers (a) Urea-formaldehyde resin (b) Phenol-formaldehyde resin
10. Estimation of iron in iron ore
11. Estimation of copper in brass
12. Estimation of dissolved oxygen by Winkler's method
13. (a) Analysis of IR spectra (minimum 3 spectra) (b) Analysis of  $^1\text{H}$  NMR spectra (minimum 3 spectra)
14. Flame photometric estimation of  $\text{Na}^+$  to find out the salinity in sand
15. Determination of acid value of a vegetable oil
16. Determination of saponification of a vegetable oil

**Reference Books**

1. G. Svehla, B. Sivasankar, "Vogel's Qualitative Inorganic Analysis", Pearson, 2012.
2. R. K. Mohapatra, "Engineering Chemistry with Laboratory Experiments", PHI Learning, 2017.
3. Muhammed Arif, "Engineering Chemistry Lab Manual", Owl publishers, 2019.
4. Ahad J., "Engineering Chemistry Lab manual", Jai Publications, 2019.
5. Roy K Varghese, "Engineering Chemistry Laboratory Manual", Crownplus Publishers, 2019.
6. Soney C George, Rino Laly Jose, "Lab Manual of Engineering Chemistry", S. Chand & Company Pvt Ltd, New Delhi, 2019.

COURSE CODE	COURSE NAME	CATEGORY	L	T	P	CREDITS
22ESL112	ELECTRICAL AND ELECTRONICS WORKSHOP	ES	0	0	2	1

**Preamble:** Electrical Workshop is intended to impart skills to plan and carry out simple electrical wiring. It is essential for the practicing engineers to identify the basic practices and safety measures in electrical wiring.

**Prerequisite:** NIL

**Course Outcomes:** After the completion of the course the student will be able to

<b>CO 1</b>	Demonstrate safety measures against electric shocks.
<b>CO 2</b>	Identify the tools used for electrical wiring, electrical accessories, wires, cables, batteries and standard symbols
<b>CO 3</b>	Develop the connection diagram, identify the suitable accessories and materials necessary for wiring simple lighting circuits for domestic buildings
<b>CO 4</b>	Identify and test various electronic components
<b>CO 5</b>	Draw circuit schematics with EDA tools
<b>CO 6</b>	Assemble and test electronic circuits on boards
<b>CO 7</b>	Work in a team with good interpersonal skills

#### Mapping of course outcomes with program outcomes

	PO 1	PO 2	PO 3	PO 4	PO 5	PO 6	PO 7	PO 8	PO 9	PO 10	PO 11	PO 12
<b>CO 1</b>	-	-	-	-	-	3	-	-	-	-	-	1
<b>CO 2</b>	2	-	-	-	-	-	-	-	-	1	-	-
<b>CO 3</b>	2	-	-	1	-	1	-	1	2	2	-	2
<b>CO 4</b>	3	-	-	-	-	-	-	-	-	-	-	2
<b>CO 5</b>	3	-	-	-	2	-	-	-	-	-	-	2
<b>CO 6</b>	3	-	-	-	2	-	-	-	-	-	-	1
<b>CO 7</b>	-	-	-	-	-	-	-	-	3	2	-	2

#### Mark distribution

Total Marks	CIE	ESE	ESE Duration(Internal)
100	100	-	1 hour

**Continuous Internal Evaluation Pattern:**

Attendance	: 20 marks
Class work/ Assessment /Viva-voce	: 50 marks
End semester examination (Internally by college)	: 30 marks

**End Semester Examination Pattern:** Written Objective Examination of one hour

**Syllabus**

**PART 1**

**ELECTRICAL**

**List of Exercises / Experiments**

1. a) Demonstrate the precautionary steps adopted in case of Electrical shocks.  
b) Identify different types of cables, wires, switches, fuses, fuse carriers, MCB, ELCB and MCCB with ratings.
2. Wiring of simple light circuit for controlling light/ fan point (PVC conduit wiring)
3. Wiring of light/fan circuit using Two way switches . (Staircase wiring)
4. Wiring of Fluorescent lamps and light sockets (6A) with a power circuit for controlling power device. (16A socket)
5. Wiring of power distribution arrangement using single phase MCB distribution board with ELCB, main switch and Energy meter.
6. a) Identify different types of batteries with their specifications.  
b) Demonstrate the Pipe and Plate Earthing Schemes using Charts/Site Visit.

**PART II**

**ELECTRONICS**

**List of Exercises / Experiments (Minimum of 7 mandatory)**

1. Familiarization/Identification of electronic components with specification (Functionality, type, size, colour coding, package, symbol, cost etc. [Active, Passive, Electrical, Electronic, Electro-mechanical], Wires, Cables, Connectors, Fuses, Switches, Relays, Crystals, Displays, Fasteners, Heat sink etc.)

# **SEMESTER - 2**

COURSE CODE	COURSE NAME	CATEGORY	L	T	P	CREDITS
22MAT201	VECTOR CALCULUS, DIFFERENTIAL EQUATIONS AND TRANSFORMS	ES	3	1	0	4

**Preamble:** This course introduces the concepts and applications of differentiation and integration of vector valued functions, differential equations, Laplace and Fourier Transforms. The objective of this course is to familiarize the prospective engineers with some advanced concepts and methods in Mathematics which include the Calculus of vector valued functions, ordinary differential equations and basic transforms such as Laplace and Fourier Transforms which are invaluable for any engineer's mathematical tool box. The topics treated in this course have applications in all branches of engineering.

**Prerequisite:** Calculus of single and multi variable functions.

**Course Outcomes:** After the completion of the course the student will be able to

CO 1	Compute the derivatives and line integrals of vector functions and learn their applications
CO 2	Evaluate surface and volume integrals and learn their inter-relations and applications.
CO 3	Solve homogeneous and non-homogeneous linear differential equation with constant coefficients
CO 4	Compute Laplace transform and apply them to solve ODEs arising in engineering
CO 5	Determine the Fourier transforms of functions and apply them to solve problems arising in engineering

#### Mapping of course outcomes with program outcomes

	PO 1	PO 2	PO 3	PO 4	PO 5	PO 6	PO 7	PO 8	PO 9	PO 10	PO 11	PO 12
CO 1	3	3	3	3	2	1			1	2		2
CO 2	3	3	3	3	2	1			1	2		2
CO 3	3	3	3	3	2	1			1	2		2
CO 4	3	3	3	3	2	1			1	2		2
CO 5	3	3	3	3	2	1			1	2		2

#### Assessment Pattern

Bloom's Category	Continuous Assessment Tests		End Semester Examination (Marks)
	Test 1 (Marks)	Test 2 (Marks)	
Remember	10	10	20
Understand	20	20	40
Apply	20	20	40
Analyse			
Evaluate			



Create			
--------	--	--	--

### Mark distribution

Total Marks	CIE (Marks)	ESE (Marks)	ESE Duration
150	50	100	3 hours

### Continuous Internal Evaluation Pattern:

Attendance : 10 marks

Continuous Assessment Test (2 numbers) : 25 marks

Assignment/Quiz/Course project : 15 marks

**Assignments:** Assignment should include specific problems highlighting the applications of the methods introduced in this course in science and engineering.

**End Semester Examination Pattern:** There will be two parts; Part A and Part B. Part A contain 10 questions with 2 questions from each module, having 3 marks for each question. Students should answer all questions. Part B contains 2 questions from each module of which student should answer any one. Each question can have maximum 2 sub-divisions and carry 14 marks.

### Course Level Assessment Questions

**Course Outcome 1 (CO1):** Compute the derivatives and line integrals of vector functions and learn their applications

1. How would you calculate the speed, velocity and acceleration at any instant of a particle moving in space whose position vector at time  $t$  is  $\mathbf{r}(t)$ ?
2. Find the work done by the force field  $F = (e^x - y^3)\mathbf{i} + (\cos y + x^3)\mathbf{j}$  on a particle that travels once around the unit circle centred at origin having radius 1.
3. When do you say that a vector field is conservative? What are the implications if a vector field is conservative?

**Course Outcome 2 (CO2):** Evaluate surface and volume integrals and learn their inter-relations and applications

1. Write any one application each of line integral, double integral and surface integral.
2. Use the divergence theorem to find the outward flux of the vector field  $F(x, y, z) = z\mathbf{k}$  across the

$$x^2 + y^2 + z^2 = a^2$$

3. State Greens theorem. Use Green's theorem to express the area of a plane region bounded by a curve as a line integral.

**Course Outcome 3 (CO3):** Solve homogeneous and non-homogeneous linear differential equation with constant coefficients

1. If  $y_1(x)$  and  $y_2(x)$  are solutions of  $y'' + py' + qy = 0$ , where  $p, q$  are constants, show that

$y_1(x) + y_2(x)$  is also a solution.

2. Solve the differential equation  $y'' + y = 0.001x^2$  using method of undetermined coefficient.

3. Solve the differential equation of  $y''' - 3y'' + 3y' - y = e^x - x - 1$ .

**Course Outcome 4 (CO4):** Compute Laplace transform and apply them to solve ODEs arising in engineering

1. What is the inverse Laplace Transform of  $(s) = \frac{3s-137}{s^2+2s+4}$ ?

2. Find Laplace Transform of Unit step function.

3. Solve the differential equation of  $y'' + 9y = \delta\left(t - \frac{\pi}{2}\right)$ ? Given  $y(0) = 2$ ,  $y'(0) = 0$

**Course Outcome 5 (CO5):** Determine the Fourier transforms of functions and apply them to solve problems arising in engineering

1. Find the Fourier integral representation of function defined by

$f(x) = e^{-x}$  for  $x > 0$  and  $f(x) = 0$  for  $x < 0$ .

2. What are the conditions for the existence of Fourier Transform of a function  $f(x)$ ?

3. Find the Fourier transform of  $f(x) = 1$  for  $|x| < 1$  and  $f(x) = 0$  otherwise.

### Model Question paper

QP CODE:

PAGES:3

Reg No: \_\_\_\_\_

Name : \_\_\_\_\_

APJ ABDUL KALAM TECHNOLOGICAL UNIVERSITY FIRST SEMESTER B.TECH DEGREE EXAMINATION,  
MONTH & YEAR

Course Code: MAT 102

Max. Marks: 100

Duration: 3 Hours

VECTOR CALCULUS, DIFFERENTIAL EQUATIONS AND TRANSFORMS

(2019-Scheme)

(Common to all branches)

## PART A

(Answer all questions. Each question carries 3 marks)

1. Is the vector  $\mathbf{r}$  where  $\mathbf{r} = x\mathbf{i} + y\mathbf{j} + z\mathbf{k}$  conservative. Justify your answer.
2. State Greens theorem including all the required hypotheses
3. What is the outward flux of  $\mathbf{F}(x, y, z) = x\mathbf{i} + y\mathbf{j} + z\mathbf{k}$  across any unit cube.
4. What is the relationship between Green's theorem and Stokes theorem?
5. Solve  $y'' + 4y' + 2.5y = 0$
6. Does the function  $y = C_1 \cos x + C_2 \sin x$  form a solution of  $y'' + y = 0$ ? Is it the general solution? Justify your answer.
7. Find the Laplace transform of  $e^{-t} \sinh 4t$
8. Find the Laplace inverse transform of  $\frac{1}{s(s^2 + \omega^2)}$ .
9. Given the Fourier transform  $\frac{1}{\sqrt{2}} e^{-\frac{\omega^2}{4}}$  of  $f(x) = e^{-x^2}$ , find the Fourier transform of  $x e^{-x^2}$
10. State the convolution theorem for Fourier transform

## PART B

(Answer one full question from each module. Each full question carries 14 marks)

### MODULE 1

11a) Prove that the force field  $\mathbf{F} = e^y \mathbf{i} + x e^y \mathbf{j}$  is conservative in the entire xy-plane

b) Use Greens theorem to find the area enclosed by the ellipse  $\frac{x^2}{a^2} + \frac{y^2}{b^2} = 1$

12 a) Find the divergence of the vector field  $\mathbf{F} = \frac{c}{(x^2 + y^2 + z^2)^{3/2}} (x\mathbf{i} + y\mathbf{j} + z\mathbf{k})$

b) Find the work done by the force field  $\mathbf{F}(x, y, z) = xy\mathbf{i} + yz\mathbf{j} + xz\mathbf{k}$  along C where

C is the curve  $\mathbf{r}(t) = t\mathbf{i} + t^2\mathbf{j} + t^3\mathbf{k}$

### MODULE II

13 a) Use divergence theorem to find the outward flux of the vector field

$\mathbf{F} = 2x\mathbf{i} + 3y\mathbf{j} + z^3\mathbf{k}$  across the unit cube bounded by or  $x = 0, y = 0, z = 0, x = 1, y = 1, z = 1$

b) Find the circulation of  $\mathbf{F} = (x - z)\mathbf{i} + (y - x)\mathbf{j} + (z - xy)\mathbf{k}$  using Stokes theorem around the triangle with vertices  $A(1,0,0), B(0,2,0)$  and  $C(0,0,1)$

14 a) Use divergence theorem to find the volume of the cylindrical solid bounded by  $x^2 + 4x + y^2 = 7, z = -1, z = 4$ , given the vector field  $\mathbf{F} = x\mathbf{i} + y\mathbf{j} + z\mathbf{k}$  across surface of the cylinder

b) Use Stokes theorem to evaluate  $\int_C \mathbf{F} \cdot d\mathbf{r}$  where  $\mathbf{F} = x^2\mathbf{i} + 3x\mathbf{j} - y^3\mathbf{k}$  where C is

the circle  $x^2 + y^2 = 1$  in the  $xy$ - plane with counterclockwise orientation looking down the positive  $z$ -axis

### MODULE III

- 15 a) Solve  $y'' + 4y' + 4y = x^2 + e^{-x} \cos x$   
b) Solve  $y''' - 3y'' + 3y' - y = e^x - x - 1$   
16 a) Solve  $y'' + 3y' + 3y = 30e^{-x}$  given  $y(0) = 3, y'(0) = -3, y''(0) = -47$   
b) Using method of variation of parameters, solve  $y'' + y = \sec x$

### MODULE IV

- 17 a) Find the inverse Laplace transform of  $F(s) = \frac{2(e^{-s} - e^{-3s})}{s^2 - 4}$   
b) Solve the differential equation  $y'' + 16y = 4\delta(t - 3\pi); y(0) = 2, y'(0) = 0$  using Laplace transform  
18 a) Solve  $y'' + 3y' + 2y = f(t)$  where  $f(t) = 1$  for  $0 < t < 1$  and  $f(t) = 1$  for  $t > 1$  using Laplace transform  
b) Apply convolution theorem to find the Laplace inverse transform of  $\frac{1}{s^2(s^2 + \omega^2)}$

### MODULE V

- 19 a) Find the Fourier cosine integral representation for  $f(x) = e^{-kx}$  for  $x > 0$  and  $k > 0$  and hence evaluate  $\int_0^\infty \frac{\cos wx}{k^2 + w^2}$  the function  
b) Does the Fourier sine transform  $f(x) = x^{-1} \sin x$  for  $0 < x < \infty$  exist? Justify your answer  
20 a) Find the Fourier transform of  $f(x) = |x|$  for  $|x| < 1$  and  $f(x) = 0$  otherwise  
b) Find the Fourier cosine transform of  $f(x) = e^{-ax}$  for  $a > 0$

## Syllabus

### Module 1 (Calculus of vector functions)

**(Text 1: Relevant topics from sections 12.1, 12.2, 12.6, 13.6, 15.1, 15.2, 15.3)**

Vector valued function of single variable, derivative of vector function and geometrical interpretation, motion along a curve-velocity, speed and acceleration. Concept of scalar and vector fields, Gradient and its properties, directional derivative, divergence and curl, Line integrals of vector fields, work as line integral, Conservative vector fields, independence of path and potential function (results without proof).

### Module 2 ( Vector integral theorems)

**(Text 1: Relevant topics from sections 15.4, 15.5, 15.6, 15.7, 15.8)**

Green's theorem (for simply connected domains, without proof) and applications to evaluating line integrals and finding areas. Surface integrals over surfaces of the form  $z = g(x, y)$ ,  $y = g(x, z)$  or  $x = g(y, z)$ , Flux integrals over surfaces of the form  $z = g(x, y)$ ,  $y = g(x, z)$  or  $x = g(y, z)$ , divergence theorem (without proof) and its applications to finding flux integrals, Stokes' theorem (without proof) and its applications to finding line integrals of vector fields and work done.

### Module- 3 ( Ordinary differential equations)

**(Text 2: Relevant topics from sections 2.1, 2.2, 2.5, 2.6, 2.7, 2.10, 3.1, 3.2, 3.3)**

Homogenous linear differential equation of second order, superposition principle, general solution, homogenous linear ODEs with constant coefficients-general solution. Solution of Euler-Cauchy equations (second order only). Existence and uniqueness (without proof). Non homogenous linear ODEs-general solution, solution by the method of undetermined coefficients (for the right hand side of the form  $x^n, e^{kx}, \sin ax, \cos ax, e^{kx} \sin ax, e^{kx} \cos ax$  and their linear combinations), methods of variation of parameters. Solution of higher order equations-homogeneous and non-homogeneous with constant coefficient using method of undetermined coefficient.

### Module- 4 (Laplace transforms)

**(Text 2: Relevant topics from sections 6.1, 6.2, 6.3, 6.4, 6.5)**

Laplace Transform and its inverse, Existence theorem (without proof), linearity, Laplace transform of basic functions, first shifting theorem, Laplace transform of derivatives and integrals, solution of differential equations using Laplace transform, Unit step function, Second shifting theorems. Dirac delta function and its Laplace transform, Solution of ordinary differential equation involving unit step function and Dirac delta functions. Convolution theorem (without proof) and its application to finding inverse Laplace transform of products of functions.

## Module-5 (Fourier Transforms)

### (Text 2: Relevant topics from sections 11.7,11.8, 11.9)

Fourier integral representation, Fourier sine and cosine integrals. Fourier sine and cosine transforms, inverse sine and cosine transform. Fourier transform and inverse Fourier transform, basic properties. The Fourier transform of derivatives. Convolution theorem (without proof)

### Text Books

1. H. Anton, I. Biven S.Davis, "Calculus", Wiley, 10<sup>th</sup> edition, 2015.
2. Erwin Kreyszig, "Advanced Engineering Mathematics", Wiley, 10<sup>th</sup> edition, 2015.

### Reference Books

1. J. Stewart, Essential Calculus, Cengage, 2<sup>nd</sup> edition, 2017
2. G.B. Thomas and R.L. Finney, Calculus and Analytic geometry, 9 th Edition, Pearson,Reprint, 2002.
3. Peter O Neil, Advanced Engineering Mathematics, 7th Edition, Thomson, 2007.
4. Louis C Barret, C Ray Wylie, "Advanced Engineering Mathematics", Tata McGraw Hill, 6<sup>th</sup> edition, 2003.
5. VeerarajanT."Engineering Mathematics for first year", Tata McGraw - Hill, 2008.
6. B.S. Grewal, Higher Engineering Mathematics, Khanna Publishers, 36<sup>th</sup> edition , 2010.
7. Srimanta Pal, Subodh C. Bhunia, "Engineering Mathematics", Oxford University Press, 2015.
8. Ronald N. Bracewell, "The Fourier Transform and its Applications", McGraw – Hill International Editions, 2000.

### Course Contents and Lecture Schedule

No	Topic	No. of Lectures
<b>1</b>	<b>Calculus of vector functions (9 hours)</b>	
1.1	Vector valued function of a scalar variable - derivative of vector valued function of scalar variable t-geometrical meaning	2
1.2	Motion along a curve-speed , velocity, acceleration	1
1.3	Gradient and its properties, directional derivative , divergent and curl	3
1.4	Line integrals with respect to arc length, line integrals of vector fields. Work done as line integral	2
1.5	Conservative vector field, independence of path, potential function	1

<b>2</b>	<b>Vector integral theorems( 9 hours)</b>	
2.1	Green's theorem and it's applications	2
2.2	Surface integrals , flux integral and their evaluation	3
2.3	Divergence theorem and applications	2
2.4	Stokes theorem and applications	2
<b>3</b>	<b>Ordinary Differential Equations (9 hours)</b>	
3.1	Homogenous linear equation of second order, Superposition principle, general solution	1
3.2	Homogenous linear ODEs of second order with constant coefficients	2
3.3	Second order Euler-Cauchy equation	1
3.4	Non homogenous linear differential equations of second order with constant coefficient-solution by undetermined coefficients, variation of parameters.	3
3.5	Higher order equations with constant coefficients	2
<b>4</b>	<b>Laplace Transform (10 hours)</b>	
4.1	Laplace Transform , inverse Transform, Linearity, First shifting theorem, transform of basic functions	2
4.2	Transform of derivatives and integrals	1
4.3	Solution of Differential equations, Initial value problems by Laplace transform method.	2
4.4	Unit step function --- Second shifting theorem	2
4.5	Dirac Delta function and solution of ODE involving Dirac delta function	2
4.6	Convolution and related problems.	1
<b>5</b>	<b>Fourier Transform (8 hours)</b>	
5.1	Fourier integral representation	1
5.2	Fourier Cosine and Sine integrals and transforms	2
5.3	Complex Fourier integral representation, Fourier transform and its inverse transforms, basic properties	3
5.4	Fourier transform of derivatives, Convolution theorem	2

COURSE CODE	COURSE NAME	CATEGORY	L	T	P	CREDITS
22PHT202	ENGINEERING PHYSICS B	ES	3	1	0	4

**Preamble:** The aim of the Engineering Physics program is to offer students a solid background in the fundamentals of Physics and to impart that knowledge in engineering disciplines. The program is designed to develop scientific attitudes and enable the students to correlate the concepts of Physics with the core programmes

**Prerequisite:** Higher secondary level Physics, Mathematical course on vector calculus, differential equations and linear algebra

**Course Outcomes:** After the completion of the course the student will be able to

CO 1	Compute the quantitative aspects of waves and oscillations in engineering systems.
CO 2	Apply the interaction of light with matter through interference, diffraction and identify these phenomena in different natural optical processes and optical instruments.
CO 3	Analyze the behaviour of matter in the atomic and subatomic level through the principles of quantum mechanics to perceive the microscopic processes in electronic devices.
CO 4	Apply the knowledge of ultrasonics in non-destructive testing and use the principles of acoustics to explain the nature and characterization of acoustic design and to provide a safe and healthy environment
CO 5	Apply the comprehended knowledge about laser and fibre optic communication systems in various engineering applications

#### Mapping of course outcomes with program outcomes

	PO 1	PO 2	PO 3	PO 4	PO 5	PO 6	PO 7	PO 8	PO 9	PO 10	PO 11	PO 12
CO 1	3	2						1	2			1
CO 2	3	2						1	2			1
CO 3	3	2						1	2			1
CO 4	3							1	2			1
CO 5	3	2						1	2			1

#### Assessment Pattern

Bloom's Category	Continuous Assessment Tests		End Semester Examination (Marks)
	Test 1 (Marks)	Test 2 (Marks)	
Remember	15	15	30
Understand	25	25	50



Apply	10	10	20
Analyse			
Evaluate			
Create			

### Mark distribution

Total Marks	CIE MARKS	ESE MARKS	ESE Duration
150	50	100	3 hours

### Continuous Internal Evaluation Pattern:

Attendance	: 10 marks
Continuous Assessment Test (2 numbers)	: 25 marks
Assignment/Quiz/Course project	: 15 marks

**End Semester Examination Pattern:** There will be two parts; Part A and Part B. Part A contain 10 questions with 2 questions from each module, having 3 marks for each question. Students should answer all questions. Part B contains 2 questions from each module of which student should answer any one. Each question can have maximum 2 sub-divisions and carry 14 marks.

### Course Level Assessment Questions

#### Course Outcome 1 (CO1):

1. Explain the effect of damping force on oscillators.
2. Distinguish between transverse and longitudinal waves.
3. (a) Derive an expression for the fundamental frequency of transverse vibration in a stretched string.  
(b) Calculate the fundamental frequency of a string of length 2 m weighing 6 g kept stretched by a load of 600 kg.

#### Course Outcome 2 (CO2):

1. Explain colours in thin films.
2. Distinguish between Fresnel and Fraunhofer diffraction.
3. (a) Explain the formation of Newton's rings and obtain the expression for radii of bright and dark rings in reflected system. Also explain how it is used to determine the wavelength of a monochromatic source of light.  
(b) A liquid of refractive index  $\mu$  is introduced between the lens and glass plate. What happens to the fringe system? Justify your answer.

#### Course Outcome 3 (CO3):

1. Give the physical significance of wave function?

2. What are excitons ?
3. (a) Solve Schrodinger equation for a particle in a one dimensional box and obtain its energy eigen values and normalised wave functions.  
(b) Calculate the first three energy values of an electron in a one dimensional box of width  $1 \text{ \AA}$  in electron volt.

**Course Outcome 4 (CO4):**

1. Explain reverberation and reverberation time.
2. How ultrasonic waves are used in non-destructive testing.
3. (a) With a neat diagram explain how ultrasonic waves are produced by a piezoelectric oscillator.  
(b) Calculate frequency of ultrasonic waves that can be produced by a nickel rod of length 4 cm. (Young's Modulus = 207 G Pa, Density =  $8900 \text{ Kg /m}^3$ )

**Course Outcome 5 (CO 5):**

1. Distinguish between spontaneous emission and stimulated emission.
2. Explain optical resonators.
3. (a) Explain the construction and working of Ruby Laser.  
(b) Calculate the numerical aperture and acceptance angle of a fibre with a core refractive index of 1.54 and a cladding refractive index of 1.50 when the fibre is inside water of refractive index 1.33.

**Model Question paper**

QP CODE:

PAGES:3

Reg No: \_\_\_\_\_

Name : \_\_\_\_\_

**APJ ABDUL KALAM TECHNOLOGICAL UNIVERSITY FIRST SEMESTER B.TECH DEGREE EXAMINATION,  
MONTH & YEAR**

**Course Code: PHT 110**

**Course Name: Engineering Physics B**

**Max.Marks: 100**

**Duration: 3 Hours**

**PART A**

**Answer all Questions. Each question carries 3 Marks**

1. Compare electrical and mechanical oscillators.
2. Distinguish between longitudinal and transverse waves.
3. Write a short note on antireflection coating.
4. Diffraction of light is not as evident in daily experience as that of sound waves. Give reason.
5. State and explain Heisenberg's Uncertainty principle. With the help of it explain natural line broadening.
6. Explain surface to volume ratio of nanomaterials.
7. Define sound intensity level. Give the values of threshold of hearing and threshold of pain.
8. Describe the method of non-destructive testing using ultra sonic waves
9. Explain the condition of population inversion
10. Distinguish between step index and graded index fibre. (10x3=30)

**PART B**

**Answer any one full question from each module. Each question carries 14 Marks**

**Module 1**

11. (a) Derive the differential equation of damped harmonic oscillator and deduce its solution. Discuss the cases of over damped, critically damped and under damped cases. (10)

(b) The frequency of a tuning fork is 500 Hz and its Q factor is  $7 \times 10^4$ . Find the relaxation time. Also calculate the time after which its energy becomes 1/10 of its initial undamped value. (4)

12. (a) Derive an expression for the velocity of propagation of a transverse wave in a stretched string. Deduce laws of transverse vibrations. (10)

(b) The equation of transverse vibration of a stretched string is given by  $y = 0.00327 \sin(72.1x - 2.72t)$  m, in which the numerical constants are in S.I. units. Evaluate (i) Amplitude (ii) Wavelength (iii) Frequency and (iv) Velocity of the wave. (4)

### Module 2

13. (a) Explain the formation of Newton's rings and show that the radius of dark ring is proportional to the square root of natural numbers. How can we use Newton's rings experiment to determine the refractive index of a liquid? (10)

(b) Two pieces of plane glass are placed together with a piece of paper between two at one end. Find the angle of the wedge in seconds if the film is viewed with a monochromatic light of wavelength  $4800 \text{ \AA}$ . Given  $\beta = 0.0555 \text{ cm}$ . (4)

14. (a) Explain the diffraction due to a plane transmission grating. Obtain the grating equation. (10)

(b) A grating has 6000 lines per cm. Find the angular separation of the two yellow lines of mercury of wavelengths 577 nm and 579 nm in the second order. (4)

### Module 3

15. (a) Derive time dependent and independent Schrodinger equations. (10)

(b) An electron is confined to one dimensional potential box of length  $2 \text{ \AA}$ . Calculate the energies corresponding to the first and second quantum states in eV. (4)

16. (a) Classify nanomaterials based on dimensionality of quantum confinement and explain the following nanostructures. (i) nano sheets (ii) nano wires (iii) quantum dots. (10)

(b) Find the de Broglie wavelength of electron whose kinetic energy is 15 eV. (4)

### Module 4

17. (a) Explain reverberation and reverberation time? What is the significance of Reverberation time. Explain the factors affecting the acoustics of a building and their corrective measures? (10)

(b) The volume of a hall is  $3000 \text{ m}^3$ . It has a total absorption of  $100 \text{ m}^2$  sabine. If the hall is filled with audience who add another  $80 \text{ m}^2$  sabine, then find the difference in reverberation time. (4)

18. (a) With a neat diagram explain how ultrasonic waves are produced by piezoelectric oscillator. Also discuss the piezoelectric method of detection of ultrasonic waves. (10)

- (b) An ultrasonic source of 0.09 MHz sends down a pulse towards the sea bed which returns after 0.55 sec. The velocity of sound in sea water is 1800 m/s. Calculate the depth of the sea and the wavelength of the pulse. (4)

**Module 5**

19. (a) Outline the construction and working of Ruby laser. (8)
- (b) What is the principle of holography? How is a hologram recorded? (6)
20. (a) Define numerical aperture of an optic fibre and derive an expression for the NA of a step index fibre with a neat diagram. (10)
- (b) An optical fibre made with core of refractive index 1.5 and cladding with a fractional index difference of 0.0006. Find refractive index of cladding and numerical aperture. (4)

(14x5=70)

## SYLLABUS

### ENGINEERING PHYSICS B (FOR NON-CIRCUIT BRANCHES)

#### Module 1

##### Oscillations and Waves

Harmonic oscillations, Damped harmonic motion-Derivation of differential equation and its solution, Over damped, Critically damped and Under damped Cases, Quality factor-Expression, Forced oscillations-Differential Equation-Derivation of expressions for amplitude and phase of forced oscillations, Amplitude Resonance-Expression for Resonant frequency, Quality factor and Sharpness of Resonance, Electrical analogy of mechanical oscillators

Wave motion- Derivation of one dimensional wave equation and its solution, Three dimensional wave equation and its solution (no derivation), Distinction between transverse and longitudinal waves, Transverse vibration in a stretched string, Statement of laws of vibration

#### Module 2

##### Wave Optics

Interference of light-Principle of superposition of waves, Theory of thin films - Cosine law (Reflected system), Derivation of the conditions of constructive and destructive Interference, Interference due to wedge shaped films -Determination of thickness and test for optical planeness, Newton's rings - Measurement of wavelength and refractive index, Antireflection coatings

Diffraction of light, Fresnel and Fraunhofer classes of diffraction, Diffraction grating-Grating equation, Rayleigh criterion for limit of resolution, Resolving and Dispersive power of a grating with expression (no derivation)

#### Module 3

##### Quantum Mechanics & Nanotechnology

Introduction for the need of Quantum mechanics, Wave nature of Particles, Uncertainty principle, Applications-Absence of electrons inside a nucleus and Natural line broadening Mechanism, Formulation of time dependent and independent Schrodinger wave equations-Physical Meaning of wave function, Particle in a one dimensional box- Derivation for normalised wave function and energy eigen values, Quantum Mechanical Tunnelling (Qualitative)

Introduction to nanoscience and technology, Increase in surface to volume ratio for nanomaterials, Quantum confinement in one dimension, two dimension and three dimension-Nano sheets, Nano wires and Quantum dots, Properties of nanomaterials-mechanical, electrical and optical, Applications of nanotechnology (qualitative ideas)

#### Module 4

##### Acoustics & Ultrasonics

Acoustics, Classification of sound-Musical sound-Noise, Characteristics of Musical Sounds-Pitch or frequency-Loudness or Intensity-Measurement of Intensity level-Decibel-Quality or timbre, Absorption coefficient, Reverberation-Reverberation time-Significance- Sabine's formula (no derivation), Factors affecting architectural acoustics and their remedies

Ultrasonics-Production- Magnetostriction effect and Piezoelectric effect, Magnetostriction oscillator and Piezoelectric oscillator –Working, Detection of ultrasonic waves - Thermal and Piezoelectric

methods, Ultrasonic diffractometer- Expression for the velocity of ultrasonic waves in a liquid , Applications of ultrasonic waves -SONAR,NDT and Medical

## **Module 5**

### **Laser and Fibre optics**

Properties of laser, Absorption and emission of radiation, Spontaneous and stimulated emission, Einstein's coefficients (no derivation), Population inversion, Metastable states, basic components of laser, Active medium, Pumping mechanism, Optical resonant cavity, working principle, Construction and working of Ruby laser and Helium neon laser ,Construction and working of semiconductor laser(Qualitative) ,Applications of laser, Holography, Difference between hologram and photograph, Recording of hologram and reconstruction of image, Applications

Optic fibre-Principle of propagation of light, Types of fibres-Step index and Graded index fibres, Numerical aperture –Derivation, Fibre optic communication system (block diagram), Industrial, Medical and Technological applications, Fibre optic sensors-Intensity Modulated and Phase modulated sensors

### **Text Books**

1. M.N.Avadhanulu, P.G.Kshirsagar,TVS Arun Murthy "A Text book of Engineering Physics", S.Chand &Co., Revised Edition, 2019.
2. H.K.Malik , A.K. Singh, "Engineering Physics" McGraw Hill Education, Second Edition, 2017.

### **Reference Books**

1. Arthur Beiser, "Concepts of Modern Physics ", Tata McGraw Hill Publications, 6th Edition 2003
2. D.K. Bhattacharya, Poonam Tandon, "Engineering Physics", Oxford University Press, 2015
3. Md.N.Khan & S.Panigrahi "Principles of Engineering Physics 1&2", Cambridge University Press, 2016
4. Aruldhas G., "Engineering Physics", PHI Pvt. Ltd., 2015
5. Ajoy Ghatak, "Optics", Mc Graw Hill Education, Sixth Edition, 2017
6. T. Pradeep, "Nano:The Essentials", McGraw Hill India Ltd, 2007
7. B. B. Laud, "Lasers and Non linear optics", New age International Publishers, 2nd Edition ,2005
8. Premlet B., "Advanced Engineering Physics", Phasor Books,10<sup>th</sup> edition ,2017
9. I. Dominic and. A. Nahari, "A Text Book of Engineering physics", Owl Books Publishers, Revised edition, 2016

### Course Contents and Lecture Schedule

No	Topic	No. of Lectures
1	<b>Oscillations and Waves ( 9 hours)</b>	
1.1	Harmonic oscillations, Damped harmonic motion-Derivation of differential equation and its solution, Over damped, Critically damped and Under damped Cases, Quality factor-Expression	2 hrs
1.2	Forced oscillations-Differential Equation-Derivation of expressions for amplitude and phase of forced oscillations, Amplitude Resonance-Expression for Resonant frequency, Quality factor and Sharpness of Resonance, Electrical analogy of mechanical oscillators	3hrs
1.3	Wave motion- Derivation of one dimensional wave equation and its solution, Three dimensional wave equation and its solution (no derivation)	2 hrs
1.4	Distinction between transverse and longitudinal waves, Transverse vibration in a stretched string, Statement of laws of vibration	2 hrs
2	<b>Wave Optics (9 hours)</b>	
2.1	Interference of light-Principle of superposition of waves, Theory of thin films - Cosine law (Reflected system), Derivation of the conditions of constructive and destructive Interference	2 hrs
2.2	Interference due to wedge shaped films -Determination of thickness and test for optical planeness, Newton's rings - Measurement of wavelength and refractive index, Antireflection coatings	4 hrs
2.3	Diffraction of light, Fresnel and Fraunhofer classes of diffraction, Diffraction grating-Grating equation	2 hrs
2.4	Rayleigh criterion for limit of resolution, Resolving and Dispersive power of a grating with expression (no derivation)	1 hr
3	<b>Quantum Mechanics &amp; Nanotechnology (9hours)</b>	
3.1	Introduction for the need of Quantum mechanics, Wave nature of Particles, Uncertainty principle, Applications-Absence of electrons inside a nucleus and Natural line broadening mechanism	2 hrs
3.2	Formulation of time dependent and independent Schrodinger wave equations-Physical Meaning of wave function, Particle in a one dimensional box- Derivation for normalised wave function and energy eigen values, Quantum Mechanical Tunnelling (Qualitative)	4 hrs
3.3	Introduction to nanoscience and technology, Increase in surface to volume ratio for nanomaterials, Quantum confinement in one dimension, two dimension and three dimension-Nano sheets, Nano wires and Quantum dots	2 hrs
3.4	Properties of nanomaterials-mechanical, electrical and optical Applications of nanotechnology (qualitative ideas)	1 hr
4	<b>Acoustics &amp; Ultrasonics (9hrs)</b>	
4.1	Acoustics, Classification of sound-Musical sound-Noise, Characteristics	3 hrs



	of Musical Sounds-Pitch or frequency-Loudness or Intensity-Measurement of Intensity level-Decibel-Quality or timbre, Absorption coefficient, Reverberation-Reverberation time-Significance- Sabine's formula (no derivation)	
4.2	Factors affecting architectural acoustics and their remedies	1 hr
4.3	Ultrasonics-Production- Magnetostriction effect and Piezoelectric effect, Magnetostriction oscillator and Piezoelectric oscillator – Working, Detection of ultrasonic waves - Thermal and Piezoelectric methods	3hrs
4.4	Ultrasonic diffractometer- Expression for the velocity of ultrasonic waves in a liquid ,Applications of ultrasonic waves -SONAR,NDT and Medical.	2 hr
5	<b>Laser and Fibre optics ( 9hours)</b>	
5.1	Properties of laser, Absorption and emission of radiation, Spontaneous and stimulated emission, Einstein's coefficients (no derivation), Population inversion, Metastable states, basic components of laser, Active medium, Pumping mechanism, Optical resonant cavity, working principle	2 hrs
5.2	Construction and working of Ruby laser and Helium neon laser ,Construction and working of semiconductor laser(Qualitative) Applications of laser	3 hrs
5.3	Holography, Difference between hologram and photograph, Recording of hologram and reconstruction of image, Applications	1 hr
5.4	Optic fibre-Principle of propagation of light, Types of fibres-Step index and Graded index fibres, Numerical aperture –Derivation, Fibre optic communication system (block diagram), Industrial, Medical and Technological applications, Fibre optic sensors-Intensity Modulated and Phase modulated sensors	3 hrs

COURSE CODE	COURSE NAME	CATEGORY	L	T	P	CREDITS
22CYT203	ENGINEERING CHEMISTRY	ES	3	1	0	4

**Preamble:** To enable the students to acquire knowledge in the concepts of chemistry for engineering applications and to familiarize the students with different application oriented topics like spectroscopy, electrochemistry, instrumental methods etc. Also familiarize the students with topics like mechanism of corrosion, corrosion prevention methods, SEM, stereochemistry, polymers, desalination etc., which enable them to develop abilities and skills that are relevant to the study and practice of chemistry.

**Prerequisite:** Concepts of chemistry introduced at the plus two levels in schools

**Course outcomes:** After the completion of the course the students will be able to

<b>CO 1</b>	Apply the basic concepts of electrochemistry and corrosion to explore its possible applications in various engineering fields.
<b>CO 2</b>	Understand various spectroscopic techniques like UV-Visible, IR, NMR and its applications.
<b>CO 3</b>	Apply the knowledge of analytical method for characterizing a chemical mixture or a compound. Understand the basic concept of SEM for surface characterisation of nanomaterials.
<b>CO 4</b>	Learn about the basics of stereochemistry and its application. Apply the knowledge of conducting polymers and advanced polymers in engineering.
<b>CO 5</b>	Study various types of water treatment methods to develop skills for treating wastewater.

#### Mapping of course outcomes with program outcomes

	PO 1	PO 2	PO 3	PO 4	PO 5	PO 6	PO 7	PO 8	PO 9	PO 10	PO 11	PO 12
<b>CO 1</b>	1	2	1									
<b>CO 2</b>	1	1		1	2							
<b>CO 3</b>	1	1		1	2							
<b>CO 4</b>	2	1										
<b>CO 5</b>	1			1			3					

### Assessment Pattern

Bloom's Category	Continuous Assessment Tests		End Semester Examination
	1	2	
Remember	15	15	30
Understand	25	25	50
Apply	10	10	20
Analyse			
Evaluate			
Create			

**End Semester Examination Pattern:** There will be two parts- **Part A** and **Part B**. **Part A** contains **10** questions (**2** questions from each module), having **3** marks for each question. Students should answer **all** questions. **Part B** contains **2** questions from each module, of which student should answer any one. Each question can have maximum **2** subdivisions and carries **14** marks.

### Course Level Assessment Questions

#### Course Outcome 1 (CO 1):

1. What is calomel electrode? Give the reduction reaction (3 Marks)
2. List three important advantages of potentiometric titration (3 Marks)
3. (a) Explain how electroless plating copper and nickel are carried out (10 Marks)  
(b) Calculate the emf of the following cell at 30°C,  $Zn / Zn^{2+} (0.1M) // Ag^+ (0.01M) // Ag$ .  
Given  $E^0 Zn^{2+}/Zn = -0.76 V$ ,  $E^0 Ag^+/Ag = 0.8 V$ . (4 Marks)

#### Course Outcome 2 (CO 2)

1. State Beer Lambert's law (3 Marks)
2. List the important applications of IR spectroscopy (3 Marks)
3. (a) What is Chemical shift? What are factors affecting Chemical shift? How  $^1H$  NMR spectrum of  $CH_3COCH_2Cl$  interpreted using the concept of chemical shift. (10 Marks)  
(b) Calculate the force constant of HF molecule, if it shows IR absorption at  $4138\text{ cm}^{-1}$ . Given that atomic masses of hydrogen and fluorine are 1u and 19u respectively. (4 Marks)

#### Course Outcome 3 (CO 3):

1. Distinguish between TGA and DTA (3 Marks)
2. Give two differences between GSC and GLC (3 Marks)

3. (a) Explain the principle, instrumentation and procedure of HPLC (10 Marks)

(b) Interpret TGA of  $\text{CaC}_2\text{O}_4 \cdot \text{H}_2\text{O}$  (4 Marks)

**Course Outcome 4 (CO 4):**

1. Explain the geometrical isomerism in double bonds (3 Marks)

2. What are the rules of assigning R-S notation? (3 Marks)

3. (a) What are conducting polymers? How it is classified? Give the preparation of polyaniline (10 Marks)

(b) Draw the stereoisomers possible for  $\text{CH}_3\text{-(CHOH)}_2\text{-COOH}$  (4 Marks)

**Course Outcome 5 (CO 5):**

1. What is degree of hardness? (3 Marks)

2. Define BOD and COD (3 Marks)

3. (a) Explain the EDTA estimation of hardness (10 Marks)

(b) Standard hard water contains 20 g of  $\text{CaCO}_3$  per liter, 50 mL of this required 30 mL of EDTA solution, 50 mL of sample water required 20 mL of EDTA solution. 50 mL sample water after boiling required 14 mL EDTA solution. Calculate the temporary hardness of the given sample of water, in terms of ppm. (4 Marks)

**MODEL QUESTION PAPER**

**Total Pages:**

Reg No.: \_\_\_\_\_

Name: \_\_\_\_\_

**APJ ABDUL KALAM TECHNOLOGICAL UNIVERSITY**  
FIRST SEMESTER B.TECH DEGREE EXAMINATION

**Course Code: CYT100,**

**Course Name: ENGINEERING CHEMISTRY**

Max. Marks: 100

Duration: 3 Hours

**PART A**

**Answer all questions, each carries 3 marks**

- |   |  | Marks |
|---|--|-------|
| 1 | What is potentiometric titration? How the end point is determined graphically?   | (3)   |
| 2 | What is Galvanic series? How is it different from electrochemical series?  | (3)   |
| 3 | Which of the following molecules can give IR absorption? Give reason?<br>(a) $\text{O}_2$ (b) $\text{H}_2\text{O}$ (c) $\text{N}_2$ (d) $\text{HCl}$ | (3)   |
| 4 | Which of the following molecules show UV-Visible absorption? Give reason.<br>(a) Ethane            (b) Butadiene            (c) Benzene              | (3)   |

- 5 What are the visualization techniques used in TLC? (3)  
 6 Write the three important applications of nanomaterials. (3)  
 7 Draw the Fischer projection formula and find R-S notation of (3)

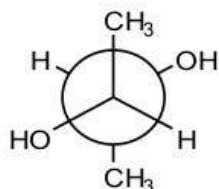

- 8 Write the structure of a) Polypyrrole b) Kevlar. (3)  
 9 What is break point chlorination? (3)  
 10 What is reverse osmosis? (3)

### PART B

**Answer any one full question from each module, each question carries 14 marks**

#### Module 1

- 11 a) Give the construction of Li-ion cell. Give the reactions that take place at the electrodes during charging and discharging. What happens to anodic material when the cell is 100% charged. (10)  
 b) Calculate the standard electrode potential of Cu, if its electrode potential at 25 °C is 0.296 V and the concentration of Cu<sup>2+</sup> is 0.015 M. (4)

**OR**

- 12 a) Explain the mechanism of electrochemical corrosion of iron in oxygen rich and oxygen deficient acidic and basic environments. (10)  
 b) Given below are reduction potentials of some species (4)

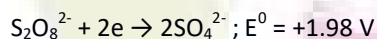
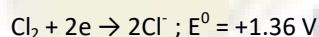
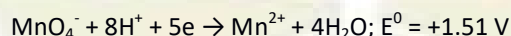

Use the above data to examine whether the acids, dil. HCl and dil. H<sub>2</sub>SO<sub>4</sub>, can be used to provide acid medium in redox titrations involving KMnO<sub>4</sub>.

#### Module 2

- 13 a) What is spin-spin splitting? Draw the NMR spectrum of (i) CH<sub>3</sub>CH<sub>2</sub>CH<sub>2</sub>Br (ii) CH<sub>3</sub>CH(Br)CH<sub>3</sub>. Explain how NMR spectrum can be used to identify the two isomers. (10)  
 b) A dye solution of concentration 0.08M shows absorbance of 0.012 at 600 nm; while a test solution of same dye shows absorbance of 0.084 under same conditions. Find the concentration of the test solution. (4)

**OR**

- 14 a) Explain the basic principle of UV-Visible spectroscopy. What are the possible electronic transitions? Explain with examples. (10)  
 b) Sketch the vibrational modes of CO<sub>2</sub> and H<sub>2</sub>O. Which of them are IR active? (4)

### Module 3

- 15 a) Explain the principle, instrumentation and procedure involved in gas chromatography. (10)  
b) Explain the DTA of  $\text{CaC}_2\text{O}_4 \cdot \text{H}_2\text{O}$  with a neat sketch. (4)

OR

- 16 a) Explain the various chemical methods used for the synthesis of nanomaterial (10)  
b) How TGA is used to analyse the thermal stability of polymers? (4)

### Module 4

- 17 a) What are conformers? Draw the *cis* and *trans* isomers of 1, 3-dimethylcyclohexane. (10)  
Which conformer (chair form) is more stable in each case?  
b) What is ABS? Give properties and applications. (4)

OR

- 18 a) Explain the various structural isomers with suitable example. (10)  
b) What is OLED? Draw a labelled diagram. (4)

### Module 5

- 19 a) What are ion exchange resins? Explain ion exchange process for removal of hardness of water? How exhausted resins are regenerated? (10)  
b) 50 mL sewage water is diluted to 2000 mL with dilution water; the initial dissolved oxygen was 7.7 ppm. The dissolved oxygen level after 5 days of incubation was 2.4 ppm. Find the BOD of the sewage. (4)

OR

- 20 a) What are the different steps in sewage treatment? Give the flow diagram. Explain the working of trickling filter. (10)  
b) Calculate the temporary and permanent hardness of a water sample which contains  $[\text{Ca}^{2+}] = 160 \text{ mg/L}$ ,  $[\text{Mg}^{2+}] = 192 \text{ mg/L}$  and  $[\text{HCO}_3^-] = 122 \text{ mg/L}$ . (4)

## Syllabus

### Module 1

#### Electrochemistry and Corrosion

Introduction - Differences between electrolytic and electrochemical cells - Daniel cell - redox reactions - cell representation. Different types of electrodes (brief) - Reference electrodes - SHE - Calomel electrode - Glass Electrode - Construction and Working. Single electrode potential - definition - Helmholtz electrical double layer - Determination of  $E^0$  using calomel electrode. Determination of pH using glass electrode. Electrochemical series and its applications. Free energy and EMF - Nernst Equation - Derivation - single electrode and cell (Numericals) - Application - Variation of emf with temperature. Potentiometric titration - Introduction - Redox titration only. Lithium ion cell - construction and working. Conductivity - Measurement of conductivity of a solution (Numericals).

Corrosion - Electrochemical corrosion - mechanism. Galvanic series - cathodic protection - electroless plating - Copper and Nickel plating.

## **Module 2**

### **Spectroscopic Techniques and Applications**

Introduction- Types of spectrum - electromagnetic spectrum - molecular energy levels - Beer Lambert's law (Numericals). UV-Visible Spectroscopy – Principle - Types of electronic transitions - Energy level diagram of ethane, butadiene, benzene and hexatriene. Instrumentation of UV-Visible spectrometer and applications. IR-Spectroscopy – Principle - Number of vibrational modes - Vibrational energy states of a diatomic molecule and -Determination of force constant of diatomic molecule (Numericals) –Applications. <sup>1</sup>H NMR spectroscopy – Principle - Relation between field strength and frequency - chemical shift - spin-spin splitting (spectral problems ) - coupling constant (definition) - applications of NMR- including MRI (brief).

## **Module 3**

### **Instrumental Methods and Nanomaterials**

Thermal analysis –TGA- Principle, instrumentation (block diagram) and applications – TGA of CaC<sub>2</sub>O<sub>4</sub>.H<sub>2</sub>O and polymers. DTA-Principle, instrumentation (block diagram) and applications - DTA of CaC<sub>2</sub>O<sub>4</sub>.H<sub>2</sub>O. Chromatographic methods - Basic principles and applications of column and TLC- Retention factor. GC and HPLC-Principle, instrumentation (block diagram) - retention time and applications.

Nanomaterials - Definition - Classification - Chemical methods of preparation - Hydrolysis and Reduction - Applications of nanomaterials - Surface characterisation -SEM – Principle and instrumentation (block diagram).

## **Module 4**

### **Stereochemistry and Polymer Chemistry**

Isomerism-Structural, chain, position, functional, tautomerism and matamerism - Definition with examples - Representation of 3D structures-Newman, Sawhorse, Wedge and Fischer projection of substituted methane and ethane. Stereoisomerism - Geometrical isomerism in double bonds and cycloalkanes (cis-trans and E-Z notations). R-S Notation – Rules and examples - Optical isomerism, Chirality, Enantiomers and Diastereoisomers-Definition with examples.Conformational analysis of ethane, butane, cyclohexane, mono and di methyl substituted cyclohexane.

Copolymers - Definition - Types - Random, Alternating, Block and Graft copolymers - ABS - preparation, properties and applications.Kevlar-preparation, properties and applications.Conducting polymers - Doping -Polyaniline and Polypyrrole - preparation properties and applications. OLED - Principle, construction and advantages.

## **Module 5**

### **Water Chemistry and Sewage Water Treatment**

Water characteristics - Hardness - Types of hardness- Temporary and Permanent - Disadvantages of hard water -Units of hardness- ppm and mg/L -Degree of hardness (Numericals) - Estimation of

hardness-EDTA method (Numericals). Water softening methods-Ion exchange process-Principle, procedure and advantages. Reverse osmosis – principle, process and advantages. Municipal water treatment (brief) - Disinfection methods - chlorination, ozone and UV irradiation.

Dissolved oxygen (DO) -Estimation (only brief procedure-Winkler's method), BOD and COD-definition, estimation (only brief procedure) and significance (Numericals). Sewage water treatment - Primary, Secondary and Tertiary - Flow diagram -Trickling filter and UASB process.

#### **Text Books**

1. B. L. Tembe, Kamaluddin, M. S. Krishnan, "Engineering Chemistry (NPTEL Web-book)", 2018.
2. P. W. Atkins, "Physical Chemistry", Oxford University Press, 10<sup>th</sup> edn., 2014.

#### **Reference Books**

1. C. N. Banwell, "Fundamentals of Molecular Spectroscopy", McGraw-Hill, 4<sup>th</sup> edn., 1995.
2. Donald L. Pavia, "Introduction to Spectroscopy", Cengage Learning India Pvt. Ltd., 2015.
3. B. R. Puri, L. R. Sharma, M. S. Pathania, "Principles of Physical Chemistry", Vishal Publishing Co., 47<sup>th</sup> Edition, 2017.
4. H. H. Willard, L. L. Merritt, "Instrumental Methods of Analysis", CBS Publishers, 7<sup>th</sup> Edition, 2005.
5. Ernest L. Eliel, Samuel H. Wilen, "Stereo-chemistry of Organic Compounds", WILEY, 2008.
6. Raymond B. Seymour, Charles E. Carraher, "Polymer Chemistry: An Introduction", Marcel Dekker Inc; 4th Revised Edition, 1996.
7. Muhammed Arif, Annette Fernandez, Kavitha P. Nair "Engineering Chemistry", Owl Books, 2019.
8. Ahad J., "Engineering Chemistry", Jai Publication, 2019.
9. Roy K. Varghese, "Engineering Chemistry", Crownplus Publishers, 2019.
10. Soney C. George, Rino Laly Jose, "Text Book of Engineering Chemistry", S. Chand & Company Pvt Ltd, 2019.



### Course Contents and Lecture Schedule

No	Topic	No. of Lectures (hrs)
<b>1</b>	<b>Electrochemistry and Corrosion</b>	<b>9</b>
<b>1.1</b>	Introduction - Differences between electrolytic and electrochemical cells- Daniel cell - redox reactions - cell representation. Different types of electrodes (brief) - Reference electrodes- SHE - Calomel electrode - Glass Electrode - Construction and Working.	<b>2</b>
<b>1.2</b>	Single electrode potential – definition - Helmholtz electrical double layer - Determination of $E^0$ using calomel electrode. Determination of pH using glass electrode. Electrochemical series and its applications. Free energy and EMF - Nernst Equation – Derivation - single electrode and cell (Numericals) -Application -Variation of emf with temperature.	<b>3</b>
<b>1.3</b>	Potentiometric titration - Introduction -Redox titration only. Lithiumion cell - construction and working. Conductivity- Measurement of conductivity of a solution (Numericals).	<b>2</b>
<b>1.4</b>	Corrosion-Electrochemicalcorrosion – mechanism. Galvanic series- cathodic protection - electroless plating –Copper and Nickel plating.	<b>2</b>
<b>2</b>	<b>Spectroscopic Techniques and Applications</b>	<b>9</b>
<b>2.1</b>	Introduction- Types of spectrum - electromagnetic spectrum - molecular energy levels - Beer Lambert's law (Numericals).	<b>2</b>
<b>2.2</b>	UV-Visible Spectroscopy – Principle - Types of electronic transitions - Energy level diagram of ethane, butadiene, benzene and hexatriene. Instrumentation of UV-Visible spectrometer and applications.	<b>2</b>
<b>2.3</b>	IR-Spectroscopy – Principle - Number of vibrational modes -Vibrational energy states of a diatomic molecule and -Determination of force constant of diatomic molecule (Numericals) –Applications.	<b>2</b>
<b>2.4</b>	$^1\text{H}$ NMR spectroscopy – Principle - Relation between field strength and frequency - chemical shift - spin-spin splitting (spectral problems ) - coupling constant (definition) - applications of NMR- including MRI (brief).	<b>3</b>
<b>3</b>	<b>Instrumental Methods and Nanomaterials</b>	<b>9</b>
<b>3.1</b>	Thermal analysis –TGA- Principle, instrumentation (block diagram) and applications – TGA of $\text{CaC}_2\text{O}_4 \cdot \text{H}_2\text{O}$ and polymers. DTA-Principle, instrumentation (block diagram) and applications - DTA of $\text{CaC}_2\text{O}_4 \cdot \text{H}_2\text{O}$ .	<b>2</b>

<b>3.2</b>	Chromatographic methods - Basic principles and applications of column and TLC- Retention factor.	<b>2</b>
<b>3.3</b>	GC and HPLC-Principle, instrumentation (block diagram) - retention time and applications.	<b>2</b>
<b>3.4</b>	Nanomaterials - Definition - Classification - Chemical methods of preparation - Hydrolysis and Reduction - Applications of nanomaterials - Surface characterisation -SEM – Principle and instrumentation (block diagram).	<b>3</b>
<b>4</b>	<b>Stereochemistry and Polymer Chemistry</b>	<b>9</b>
<b>4.1</b>	Isomerism-Structural, chain, position, functional, tautomerism and matamerism - Definition with examples - Representation of 3D structures-Newman, Sawhorse, Wedge and Fischer projection of substituted methane and ethane. Stereoisomerism - Geometrical isomerism in double bonds and cycloalkanes (cis-trans and E-Z notations).	<b>2</b>
<b>4.2</b>	R-S Notation – Rules and examples - Optical isomerism, Chirality, Enantiomers and Diastereoisomers-Definition with examples.	<b>1</b>
<b>4.3</b>	Conformational analysis of ethane, butane, cyclohexane, mono and di methyl substituted cyclohexane.	<b>2</b>
<b>4.4</b>	Copolymers - Definition - Types - Random, Alternating, Block and Graft copolymers - ABS - preparation, properties and applications. Kevlar-preparation, properties and applications. Conducting polymers - Doping -Polyaniline and Polypyrrole - preparation properties and applications. OLED - Principle, construction and advantages.	<b>4</b>
<b>5</b>	<b>Water Chemistry and Sewage Water Treatment</b>	<b>9</b>
<b>5.1</b>	Water characteristics - Hardness - Types of hardness- Temporary and Permanent - Disadvantages of hard water -Units of hardness- ppm and mg/L -Degree of hardness (Numericals) - Estimation of hardness-EDTA method (Numericals). Water softening methods-Ion exchange process-Principle, procedure and advantages. Reverse osmosis – principle, process and advantages.	<b>3</b>
<b>5.2</b>	Municipal water treatment (brief) - Disinfection methods - chlorination, ozone andUV irradiation.	<b>2</b>
<b>5.3</b>	Dissolved oxygen (DO) -Estimation (only brief procedure-Winkler’s method), BOD and COD-definition, estimation (only brief procedure) and significance (Numericals).	<b>2</b>
<b>5.4</b>	Sewage water treatment - Primary, Secondary and Tertiary - Flow diagram - Trickling filter and UASB process.	<b>2</b>

COURSE CODE	COURSE NAME	CATEGORY	L	T	P	CREDITS
22EST204	ENGINEERING MECHANICS	ES	2	1	0	3

**Preamble:** Goal of this course is to expose the students to the fundamental concepts of mechanics and enhance their problem-solving skills. It introduces students to the influence of applied force system and the geometrical properties of the rigid bodies while stationary or in motion. After this course students will be able to recognize similar problems in real-world situations and respond accordingly.

**Prerequisite:** Nil

**Course Outcomes:** After completion of the course the student will be able to:

<b>CO 1</b>	Recall principles and theorems related to rigid body mechanics
<b>CO 2</b>	Identify and describe the components of system of forces acting on the rigid body
<b>CO 3</b>	Apply the conditions of equilibrium to various practical problems involving different force system.
<b>CO 4</b>	Choose appropriate theorems, principles or formulae to solve problems of mechanics.
<b>CO 5</b>	Solve problems involving rigid bodies, applying the properties of distributed areas and masses

**Mapping of course outcomes with program outcomes (Minimum requirement)**

	PO 1	PO 2	PO 3	PO 4	PO 5	PO 6	PO 7	PO 8	PO 9	PO 10	PO 11	PO 12
<b>CO 1</b>	2	2	-	-	-	-	-	-	-	-	-	-
<b>CO 2</b>	3	3	-	-	-	-	-	-	-	-	-	-
<b>CO 3</b>	3	3	-	-	-	-	-	-	-	-	-	-
<b>CO 4</b>	3	3	-	-	-	-	-	-	-	-	-	-
<b>CO 5</b>	3	3	-	-	-	-	-	-	-	-	-	-

**Assessment Pattern**

Bloom's Category	Continuous Assessment Tests		End Semester Examination (Marks)
	Test 1 (Marks)	Test 2 (Marks)	
Remember	10	10	15
Understand	10	10	15
Apply	30	30	70
Analyse			
Evaluate			
Create			

### Mark distribution

Total Marks	CIE marks	ESE marks	ESE Duration
150	50	100	3 hours

#### Continuous Internal Evaluation Pattern:

Attendance	: 10 marks
Continuous Assessment Test (2 numbers)	: 25 marks
Assignment/Quiz/Course project	: 15 marks

**End Semester Examination Pattern:** There will be two parts; Part A and Part B. Part A contain 10 questions with 2 questions from each module, having 3 marks for each question. Students should answer all questions. Part B contains 2 questions from each module of which student should answer any one. Each question can have maximum 2 sub-divisions and carry 14 marks.

#### Course Level Assessment Questions:

##### Part A

**Course Outcome 1 (CO1):** (One question from each module to meet the course objective 1: *To recall principles and theorems related to rigid body mechanics*)

1. Explain D'Alembert's principle
2. Distinguish static and dynamic friction
3. State and explain perpendicular axis theorem

**Course Outcome 2 (CO2)** (One question from each module to meet the course objective 2: *To identify and describe the components of system of forces acting on the rigid body*)

1. A simply supported beam AB of span 5 m is carrying point loads 5 kN, 3 kN and 2 kN at 1m, 3m and 4m respectively from support A. Calculate the support reaction at B.
2. A gymnast holding onto a bar, is suspended motionless in mid-air. The bar is supported by two ropes that attach to the ceiling. Diagram the forces acting on the combination of gymnast and bar
3. While you are riding your bike, you turn a corner following a circular arc. Illustrate the forces that act on your bike to keep you along the circular path ?

##### Part B

All the questions under this section shall assess the learning levels corresponding to the course outcomes listed below.

<b>CO 3</b>	To apply the conditions of equilibrium to various practical problems involving different force system.
<b>CO 4</b>	To choose appropriate theorems, principles or formulae to solve problems of mechanics.
<b>CO 5</b>	To solve problems involving rigid bodies, applying the properties of distributed areas and masses

1. Two rollers each of weight 100 N are supported by an inclined plane and a vertical wall. Find the reaction at the points of contact A, B, C. Assume all the surfaces to be smooth.

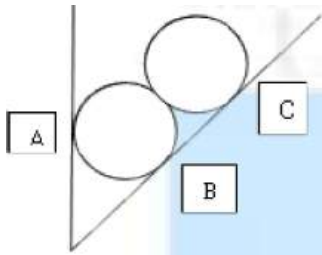

Course outcome identifier	Description of course outcome	Learning level assessed	Marks allocated
<b>CO 3</b>	To apply the conditions of equilibrium to various practical problems involving different force system.	Applying – (Sketch the free body diagram that represent equilibrium state of the body )	4
<b>CO 4</b>	To choose appropriate theorems, principles or formulae to solve problems of mechanics.	Applying (Choose the equations and formulae required for calculation)	4
<b>CO 5</b>	To solve problems involving rigid bodies, applying the properties of distributed areas and masses	Applying ( Solve the problem based on the descriptions given in CO3 and CO4)	6
Total			14

2. A cylindrical disc, 50 cm diameter and cm thickness, is in contact with a horizontal conveyer belts running at uniform speeds of 5 m/s. Assuming there is no slip at points of contact determine (i) angular velocity of disc (ii) Angular acceleration of disc if velocity of conveyer changes to 8 m/s. Also compute the moment acting about the axis of the disc in both cases.

Course outcome identifier	Description of course outcome	Learning level assessed	Marks allocated
CO 3	To apply the conditions of equilibrium to various practical problems involving different force system.	Applying – (Sketch the free body diagram that represent state of the body )	4
CO 4	To choose appropriate theorems, principles or formulae to solve problems of mechanics.	Applying (Choose the equations and formulae required for calculation)	4
CO 5	To solve problems involving rigid bodies, applying the properties of distributed areas and masses	Applying ( Solve the problem based on the descriptions given in CO3 and CO4)	6
Total			14

3. Determine the centroid of the given section

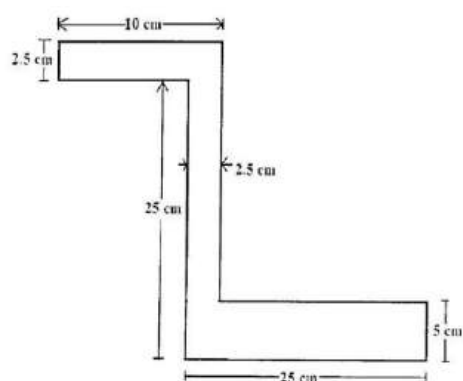

Course outcome identifier	Description of course outcome	Learning level assessed	Marks allocated
CO 3	To apply the conditions of equilibrium to various practical problems involving different force system.	Applying – (Illustrate the computation of centroid for the given geometrical shape)	4
CO 4	To choose appropriate theorems, principles or formulae to solve problems of mechanics.	Applying (Choose the equations and formulae required for calculation)	4
CO 5	To solve problems involving rigid bodies, applying the properties of distributed	Applying ( Solve the problem based on the descriptions	6

	areas and masses	given in CO3 and CO4)	
Total			14

4. A rectangular hole is made in a triangular section as shown. Find moment of inertia about the section x-x passing through the CG of the section and parallel to BC.

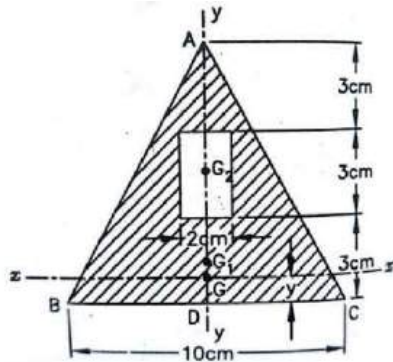

Course outcome identifier	Description of course outcome	Learning level assessed	Marks allocated
CO 3	To apply the conditions of equilibrium to various practical problems involving different force system.	Applying – (Illustrate the computation of moment of inertia for the given geometrical shape)	4
CO 4	To choose appropriate theorems, principles or formulae to solve problems of mechanics.	Applying (Choose the equations and formulae required for calculation)	4
CO 5	To solve problems involving rigid bodies, applying the properties of distributed areas and masses	Applying ( Solve the problem based on the descriptions given in CO3 and CO4)	6
Total			14

**Model Question Paper**

**QP CODE:**

Reg No.: \_\_\_\_\_

Name: \_\_\_\_\_

**APJ ABDUL KALAM TECHNOLOGICAL UNIVERSITY FIRST SEMESTER B.TECH DEGREE EXAMINATION,  
MONTH & YEAR**

**Course Code: EST 100**

**ENGINEERING MECHANICS**

Max. Marks: 100

Duration: 3 hours

**Part A**

(Answer all questions; each question carries 3 marks)

1. Explain D'Alembert's principle
2. Distinguish static and dynamic friction.
3. State and explain perpendicular axis theorem.
4. A simply supported beam AB of span 5 m is carrying point loads 5 kN, 3 kN and 2 kN at 1m, 3m and 4m respectively from support A. Calculate the support reaction at B.
5. A gymnast holding onto a bar, is suspended motionless in mid-air. The bar is supported by two ropes that attach to the ceiling. Diagram the forces acting on the combination of gymnast and bar
6. While you are riding your bike, you turn a corner following a circular arc. Illustrate the forces that act on your bike to keep you along the circular path ?
7. Compare damped and undamped free vibrations.
8. State the equation of motion of a rotating rigid body, rotating about its fixed axis.
9. Illustrate the significance of instantaneous centre in the analysis of rigid body undergoing rotational motion.
10. Highlight the principles of mechanics applied in the evaluation of elastic collision of rigid bodies.

**PART B**

(Answer **one full** question from each module, each question carries **14** marks)

**Module -I**

11. Two identical rollers each of weight 100 N are supported by an inclined plane, making an angle of  $30^\circ$  with the vertical, and a vertical wall. Find the reaction at the points of contact A, B, C. Assume all the surfaces to be smooth. (14 marks)



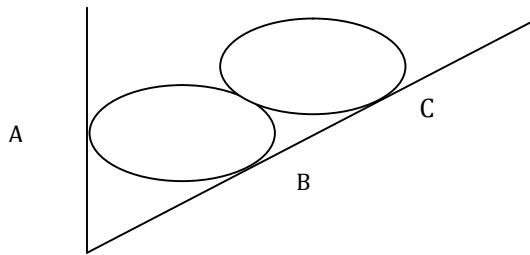

12. A string tied to a wall is made to pass over a pulley placed 2m away from it. A weight P is attached to the string such that the string stretches by 2m from the support on the wall to the location of attachment of weight. Determine the force P required to maintain 200 kg body in position for  $\theta = 30^\circ$ , The diameter of pulley B is negligible. (14 marks)

**Module – 2**

13. Two blocks A & B are resting against a wall and the floor as shown in figure below. Find the value of horizontal force P applied to the lower block that will hold the system in equilibrium. Coefficient of friction are : 0.25 at the floor, 0.3 at the wall and 0.2 between the blocks. (14 marks)

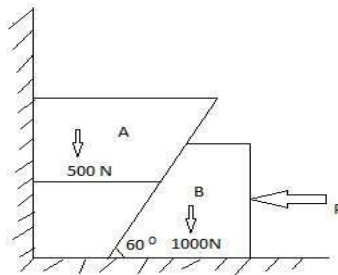

14. A beam is hinged at A and roller supported at B. It is acted upon by loads as shown below. Find the reactions at A & B. (14 marks)

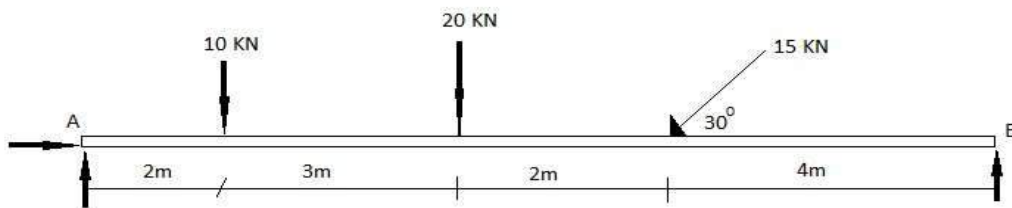

**Module – 3**

15. A rectangular hole is made in a triangular section as shown. Find moment of inertia about the section x-x passing through the CG of the section and parallel to BC. (14 marks)

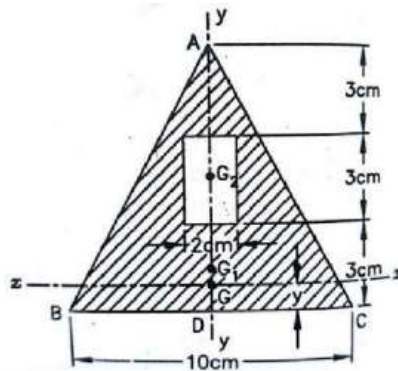

16. Support A has ball and socket connection. Roller support at B prevents motion in the  $-z$  direction. Corner C is tied to D by a rope. The triangle is weightless. Determine the unknown force components acting at A, B, and C. (14 marks)

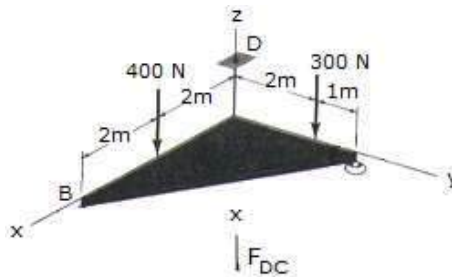

#### Module - 4

17. A cricket ball is thrown by a fielder from a height of 2m at an angle of  $30^\circ$  to the horizontal with an initial velocity of 20 m/s, hits the wickets at a height of 0.5 m from the ground. How far was the fielder from the wicket? (14 marks)

18. An engine of weight 500 kN pull a train weighing 1500 kN up an incline of 1 in 100. The train starts from rest and moves with constant acceleration against a resistance of 5 N/kN. It attains a maximum speed of 36 kmph in 1 km distance. Determine the tension in the coupling between train and engine and the traction force developed by the engine. (14marks)

#### Module – 5

19. A cylindrical disc, 50 cm diameter and 10 cm thickness having mass of 10 kg, is in contact with a horizontal conveyor belt running at uniform speeds of 5 m/s. Assuming there is no slip at points of contact determine (i) angular velocity of disc (ii) Angular acceleration of disc if velocity of conveyor changes to 8 m/s in 10 seconds. Also compute the moment acting about the axis of the disc in both cases. (14 marks)

20. A wheel rotating about fixed axis at 20 rpm is uniformly accelerated for 70 seconds during which time it makes 50 revolutions. Find the (i) angular velocity at the end of this interval and (ii) time required for the velocity to reach 100 revolutions per minute. (14 marks)

## SYLLABUS

### Module 1

Introduction to Engineering Mechanics-statics-basic principles of statics-Parallelogram law, equilibrium law, principles of superposition and transmissibility, law of action and reaction(review) free body diagrams.

Concurrent coplanar forces-composition and resolution of forces-resultant and equilibrium equations – methods of projections – methods of moments – Varignon's Theorem of moments.

### Module 2

Friction – sliding friction - Coulomb's laws of friction – analysis of single bodies –wedges, ladder-analysis of connected bodies .

Parallel coplanar forces – couple - resultant of parallel forces – centre of parallel forces – equilibrium of parallel forces – Simple beam subject to concentrated vertical loads. General coplanar force system - resultant and equilibrium equations.

### Module 3

Centroid of composite areas- – moment of inertia-parallel axis and perpendicular axis theorems. Polar moment of inertia, radius of gyration, mass moment of inertia-ring, cylinder and disc.

Theorem of Pappus Guldinus(demonstration only)

Forces in space - vectorial representation of forces, moments and couples –resultant and equilibrium equations – concurrent forces in space (simple problems only)

### Module 4

Dynamics – rectilinear translation - equations of kinematics(review)

kinetics – equation of motion – D'Alembert's principle. – motion on horizontal and inclined surfaces, motion of connected bodies. Impulse momentum equation and work energy equation (concepts only).

Curvilinear translation - equations of kinematics –projectile motion(review), kinetics – equation of motion. Moment of momentum and work energy equation (concepts only).

### Module 5

Rotation – kinematics of rotation- equation of motion for a rigid body rotating about a fixed axis – rotation under a constant moment.

Plane motion of rigid body – instantaneous centre of rotation (concept only).

Simple harmonic motion – free vibration –degree of freedom- undamped free vibration of spring mass system-effect of damping(concept only)

### Text Books

1. Timoshenko and Young, Engineering Mechanics, McGraw Hill Publishers
2. Shames, I. H., Engineering Mechanics - Statics and Dynamics, Prentice Hall of India.
3. R. C. Hibbeler and Ashok Gupta, Engineering Mechanics, Vol. I statics, Vol II Dynamics, Pearson Education.

## References

1. Merriam J. L and Kraige L. G., Engineering Mechanics - Vols. 1 and 2, John Wiley.
2. Tayal A K, Engineering Mechanics – Statics and Dynamics, Umesh Publications
3. Bhavikkatti, S.S., Engineering Mechanics, New Age International Publishers
4. F.P.Beer and E.R.Johnston (2011), Vector Mechanics for Engineers, Vol.I-Statics, Vol.II-Dynamics, 9<sup>th</sup> Ed, Tata McGraw Hill
5. Rajasekaran S and Sankarasubramanian G, Engineering Mechanics - Statics and Dynamics, Vikas Publishing House Pvt Ltd.

## Course Contents and Lecture Schedule:

Module	Topic	Course outcomes addressed	No. of Hours
<b>1</b>	<b>Module 1</b>		<b>Total: 7</b>
1.1	Introduction to engineering mechanics – introduction on statics and dynamics - Basic principles of statics – Parellogram law, equilibrium law – Superposition and transmissibility, law of action and reaction (review the topics)	CO1 and CO2	1
1.2	Free body diagrams. Degree of freedom-types of supports and nature of reactions - exercises for free body diagram preparation – composition and resolution of forces, resultant and equilibrium equations (review the topics) - numerical exercises for illustration.	CO1 and CO2	1
1.3	Concurrent coplanar forces - analysis of concurrent forces -methods of projections – illustrative numerical exercise – teacher assisted problem solving.	CO1 and CO2	1
1.4	Analysis of concurrent forces -methods of moment-Varignon’s Theorem of Moments - illustrative numerical exercise– teacher assisted problem solving.	CO1 and CO2	1
1.5	Analysis of concurrent force systems – extended problem solving - Session I.	CO3,CO4 and CO5	1
1.6	Analysis of concurrent force systems – extended problem solving - Session II – learning review quiz.	CO3,CO4 and CO5	1
1.7	Analysis of concurrent force systems – extended problem solving - Session III.	CO3,CO4 and CO5	1
<b>2</b>	<b>Module 2</b>		<b>Total: 7</b>
2.1	Friction – sliding friction - Coulomb’s laws of friction – analysis of single bodies –illustrative examples on wedges and ladder-teacher	CO1 and CO2	1

	assisted problem solving tutorials using problems from wedges and ladder.		
2.2	Problems on friction - analysis of connected bodies. illustrative numerical exercise– teacher assisted problem solving.	CO3, CO4 and CO5	1
2.3	Problems on friction-extended problem solving	CO3,CO4 and CO5	1
2.4	Parallel coplanar forces – couple - resultant of parallel forces – centre of parallel forces – equilibrium of parallel forces – Simple beam subject to concentrated vertical loads.	CO1 and CO2	1
2.5	General coplanar force system - resultant and equilibrium equations - illustrative examples- teacher assisted problem solving.	CO1 and CO2	1
2.6	General coplanar force system-resultant and equilibrium equations - illustrative examples	CO3, CO4 and CO5	1
2.7	General coplanar force system - Extended problem solving - Quiz to evaluate learning level.	CO3, CO4 and CO5	1
<b>3</b>	<b>Module 3</b>		<b>Total: 7</b>
3.1	Centroid of simple and regular geometrical shapes – centroid of figures in combination - composite areas- examples for illustration – problems for practice to be done by self.	CO1 and CO2	1
3.2	Moment of inertia- parallel axis theorem –examples for illustration - problems for practice to be done by self.	CO1 and CO2	1
3.3	Moment of inertia - perpendicular axis theorem - example for illustration to be given as hand out and discussion on the solved example.	CO1 and CO2	1
3.4	Solutions to practice problems – problems related to centroid and moment of inertia - problems for practice to be done by self.	CO3, CO4 and CO5	1
3.5	Polar moment of inertia, Radius of gyration. Mass moment of inertia of ring, cylinder and uniform disc. Theorem of Pappus Guldinus - Demonstration	CO1 and CO2	1
3.6	Introduction to forces in space – vectorial representation of forces, moments and couples – simple problems to illustrate vector representations of forces, moments and couples to be done in class.	CO1,and CO2	1
3.7	Solution to practice problems - resultant and equilibrium equations for concurrent forces in space – concurrent forces in space - 2 simple problems to illustrate the application of resultant and equilibrium equations for concurrent forces in space.	CO3,CO4 and CO5	1
<b>4</b>	<b>Module 4</b>		<b>Total: 7</b>

4.1	Introduction to dynamics – review of rectilinear translation - equations of kinematics – problems to review the concepts – additional problems involving extended application as exercises .	CO1 and CO2	1
4.2	Solutions to exercises with necessary explanation given as hand out – introduction to kinetics – equation of motion – D’Alembert’s principle – illustration of the concepts using one numerical exercise from motion on horizontal and inclined surfaces.	CO1 and CO2	1
4.3	Motion of connected bodies - example for illustration to be given as hand out and discussion on the solved example – problems for practice to be done by self.	CO3, CO4 and CO5	1
4.4	Motion of connected bodies-extended problem solving.	CO3, CO4 & CO5	1
4.5	Curvilinear translation - Review of kinematics –projectile motion – simple problems to review the concepts – introduction to kinetics – equation of motion – illustration of the concepts using numerical exercises.	CO3, CO4 & CO5	1
4.6	Extended problem solving – rectilinear and curvilinear translation.	CO3, CO4 & CO5	1
4.7	Concepts on Impulse momentum equation and work energy equation (rectilinear translation – discussions to bring out difference between elastic and inelastic collisions). Concepts on Moment of momentum and work energy equation (curvilinear translation).	CO1 and CO2	1
<b>5</b>	<b>Module 5</b>		<b>Total: 7</b>
5.1	Rotation – kinematics of rotation- equation of motion for a rigid body rotating about a fixed axis – simple problems for illustration.	CO1 and CO2	1
5.2	Rotation under a constant moment – teacher assisted problem solving.	CO3,CO4 and CO5	1
5.3	Rotation under a constant moment - extended problem solving.	CO3, CO4 and CO5	1
5.4	Plane motion of rigid body- instantaneous centre of rotation (concept only).	CO1 and CO2	1
5.5	Introduction to harmonic oscillation –free vibrations - simple harmonic motion – differential equation and solution.  Degree of freedom – examples of single degree of freedom (SDOF) systems – Idealisation of mechanical systems as spring-mass systems (concept only).	CO1 and CO2	1

5.6	SDOF spring mass system –equation of motion – undamped free vibration response - concept of natural frequency. Free vibration response due to initial conditions. Simple problems on determination of natural frequency and free vibration response to test the understanding level.	CO1 and CO2	1
5.7	Free vibration analysis of SDOF spring-mass systems – Problem solving Effect of damping on free vibration response (concept only).	CO1and CO2	1

COURSE CODE	COURSE NAME	CATEGORY	L	T	P	CREDITS
22EST205	ENGINEERING GRAPHICS	ES	2	0	2	3

**Preamble:** To enable the student to effectively perform technical communication through graphical representation as per global standards.

**Prerequisite:** NIL

**Course Outcomes:** After the completion of the course the student will be able to

<b>CO 1</b>	Draw the projection of points and lines located in different quadrants
<b>CO 2</b>	Prepare multiview orthographic projections of objects by visualizing them in different positions
<b>CO 3</b>	Draw sectional views and develop surfaces of a given object
<b>CO 4</b>	Prepare pictorial drawings using the principles of isometric and perspective projections to visualize objects in three dimensions.
<b>CO 5</b>	Convert 3D views to orthographic views
<b>CO 6</b>	Obtain multiview projections and solid models of objects using CAD tools

#### Mapping of course outcomes with program outcomes

	PO 1	PO 2	PO 3	PO 4	PO 5	PO 6	PO 7	PO 8	PO 9	PO 10	PO 11	PO 12
<b>CO 1</b>	3											
<b>CO 2</b>	3											
<b>CO 3</b>	3	1										
<b>CO 4</b>	3									1		
<b>CO 5</b>	3									2		
<b>CO 6</b>	3				3					3		

#### Assessment Pattern

Bloom's Category	Continuous Assessment Tests		End Semester Examination (100 Marks)
	Test 1 (15 Marks)	Test 2 (15 Marks)	
Remember			
Understand	5		20
Apply	10	10	80
Analyse			
Evaluate			
Create			



### Mark distribution

Total Marks	CIE (Marks)	ESE (Marks)	ESE Duration
150	50	100	3 hours

### Continuous Internal Evaluation Pattern:

Attendance : 10 marks

CIA for section A carries 25 marks (15 marks for 1 test and Class work 10 marks)

CIA for section B carries 15 marks (10 marks for 1 test and Class work 5 marks)

### End Semester Examination Pattern:

ESE will be of 3 hour duration on A4 size answer booklet and will be for 100 marks. The question paper shall contain two questions from each module of Section A only. Student has to answer any one question from each module. Each question carries 20 marks.

### Course Level Assessment Questions

(Questions may be framed based on the outline given under each course outcome)

#### Course Outcome 1 (CO1):

1. Locate points in different quadrants as per given conditions.
2. Problems on lines inclined to both planes .
3. Find True length, Inclinations and Traces of lines.

#### Course Outcome 2 (CO2)

1. Draw orthographic views of solids and combination solids
2. Draw views of solids inclined to any one reference plane.
3. Draw views of solids inclined to both reference planes.

#### Course Outcome 3 (CO3):

1. Draw views of solids sectioned by a cutting plane
2. Find location and inclination of cutting plane given true shape of the section
3. Draw development of lateral surface of solids and also its sectioned views

#### Course Outcome 4 (CO4):

1. Draw Isometric views/projections of solids
2. Draw Isometric views/projections of combination of solids
3. Draw Perspective views of Solids

#### Course Outcome 5 (CO5):

1. Draw Orthographic views of solids from given three dimensional view

**Course Outcome 6 (CO6):**

1. Draw the given figure including dimensions using 2D software
2. Create 3D model using modelling software from the given orthographic views or 3D figure or from real 3D objects

**Model Question paper**

**QP CODE:**

**PAGES:3**

Reg No: \_\_\_\_\_

Name : \_\_\_\_\_

**APJ ABDUL KALAM TECHNOLOGICAL UNIVERSITY FIRST SEMESTER B.TECH DEGREE EXAMINATION,  
MONTH & YEAR**

**Course Code: EST 110**

**ENGINEERING GRAPHICS**

**Max.Marks:100**

**Duration: 3 Hours**

**PART A**

**Answer all Questions. Each question carries 3 Marks**

**Instructions: Retain necessary Construction lines**

**Show necessary dimensions**

**Answer any ONE question from each module**

**Each question carries 20 marks**

**MODULE I**

1. The end point A of a line is 20mm above HP and 10mm in front of VP. The other end of the line is 50mm above HP and 15mm behind VP. The distance between the end projectors is 70mm. Draw the projections of the line. Find the true length and true inclinations of the line with the principal planes. Also locate the traces of the line.
2. One end of a line is 20mm from both the principal planes of projection. The other end of the line is 50mm above HP and 40mm in front of VP. The true length of the line is 70mm. Draw the projections of the line. Find its apparent inclinations, elevation length and plan length. Also locate its traces.

**MODULE II**

3. A pentagonal pyramid of base side 25mm and height 40mm, is resting on the ground on one of its triangular faces. The base edge of that face is inclined  $30^\circ$  to VP. Draw the projections of the solid.

- A hexagonal prism has side 25mm and height 50mm has a corner of its base on the ground and the long edge containing that corner inclined at  $30^\circ$  to HP and  $45^\circ$  to VP. Draw the projections of the solid.

### MODULE III

- A triangular prism of base side 40mm and height 70mm is resting with its base on the ground and having an edge of the base perpendicular to VP. Section the solid such that the true shape of the section is a trapezium of parallel sides 30mm and 10mm. Draw the projections showing the true shape. Find the inclination of the cutting plane with the ground plane.
- Draw the development of a pentagonal pyramid of base side 30mm and height 50mm. A string is wound from a corner of the base round the pyramid and back to the same point through the shortest distance. Show the position of the string in the elevation and plan.

### MODULE IV

- The frustum of a cone has base diameter 50mm and top diameter 40mm has a height of 60mm. It is placed centrally on top of a rectangular slab of size 80x60mm and of thickness 20mm. Draw the isometric view of the combination.
- A hexagonal prism has base side 35mm and height 60mm. A sphere of diameter 40mm is placed centrally on top of it. Draw the isometric projection of the combination.

### MODULE V

- Draw the perspective view of a pentagonal prism, 20mm side and 45mm long lying on one of its rectangular faces on the ground and having its axis perpendicular to picture plane. One of its pentagonal faces touches the picture plane and the station point is 50mm in front of PP, 25mm above the ground plane and lies in a central plane, which is 70mm to the left of the center of the prism.
- Draw three orthographic views with dimensions of the object shown in figure below.

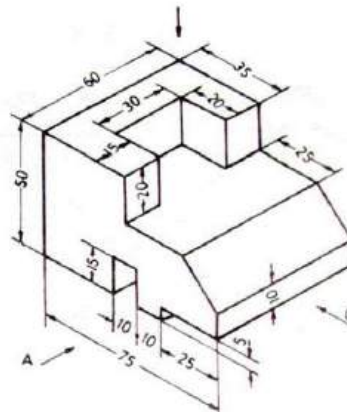

(20X5=100)

**Time : 3 hours**

**EST110 ENGINEERING GRAPHICS**

**Max. Marks: 100**

**SCHEME OF VALUATION**

1. Locating the points and drawing the projections of the line – 4 marks  
Finding true length by any one method – 6 marks  
Finding true inclination with VP – 2 marks  
Finding true inclination with HP – 2 marks  
Locating horizontal trace – 2 marks  
Locating vertical trace – 2 marks  
Dimensioning and neatness – 2 marks

Total = 20 marks

2. Locating the points and drawing true length of the line – 4 marks  
Finding projections by any method – 6 marks  
Finding length of elevation and plan – 2 marks  
Finding apparent inclinations – 2 marks  
Locating horizontal trace – 2 marks  
Locating vertical trace – 2 marks  
Dimensioning and neatness – 2 marks

Total = 20 marks

3. Drawing initial position plan and elevation – 4 marks  
First inclination views – 4 marks  
Second inclination views -8 marks  
Marking invisible edges – 2 marks  
Dimensioning and neatness – 2 marks

Total = 20 marks

*(Any one method or combination of methods for solving can be used.*

*If initial position is wrong then maximum 50% marks may be allotted for the answer)*

4. Drawing initial position plan and elevation – 4 marks  
First inclination views – 4 marks  
Second inclination views -8 marks  
Marking invisible edges – 2 marks  
Dimensioning and neatness – 2 marks

Total = 20 marks

*(Any one method or combination of methods for solving can be used*

*If initial position is wrong then maximum 50% marks may be allotted for the answer)*

5. Drawing initial position plan and elevation – 4 marks  
Locating section plane as per given condition – 5 marks  
Drawing true shape -5 marks  
Finding inclination of cutting plane – 2 marks  
Dimensioning and neatness – 2 marks

Total = 20 marks

6. Drawing initial position plan and elevation – 4 marks  
Development of the pyramid – 6 marks

Locating string in development -2 marks  
Locating string in elevation – 3 marks  
Locating string in plan – 3 marks  
Dimensioning and neatness – 2 marks

Total = 20 marks

7. Drawing initial positions – 4 marks  
Isometric View of Slab -6 marks  
Isometric View of Frustum – 10 marks  
Dimensioning and neatness – 2 marks

Total = 20 marks

*(Initial position is optional, hence redistribute if needed.  
Reduce 4 marks if Isometric scale is taken)*

8. Drawing initial positions – 4 marks  
Isometric scale – 4 marks  
Isometric projection of prism -5 marks  
Isometric projection of sphere – 5 marks  
Dimensioning and neatness – 2 marks

Total = 20 marks

*(Initial position is optional, hence redistribute if needed.)*

9. Drawing the planes and locating the station point – 4 marks  
Locating elevation points – 2 marks  
Locating plan points – 2 marks  
Drawing the perspective view – 10 marks  
Dimensioning and neatness – 2 marks

Total = 20 marks

10. Drawing the elevation – 8marks  
Drawing the plan – 4 marks  
Drawing the side view – 4 marks  
Marking invisible edges – 2 marks  
Dimensioning and neatness – 2 marks

Total = 20 marks

## SYLLABUS

General Instructions:

- First angle projection to be followed
- Section A practice problems to be performed on A4 size sheets
- Section B classes to be conducted on CAD lab

### SECTION A

#### Module 1

Introduction : Relevance of technical drawing in engineering field. Types of lines, Dimensioning, BIS code of practice for technical drawing.

Orthographic projection of Points and Lines: Projection of points in different quadrants, Projection of straight lines inclined to one plane and inclined to both planes. Trace of line. Inclination of lines with reference planes True length of line inclined to both the reference planes.

#### Module 2

Orthographic projection of Solids: Projection of Simple solids such as Triangular, Rectangle, Square, Pentagonal and Hexagonal Prisms, Pyramids, Cone and Cylinder. Projection of solids in simple position including profile view. Projection of solids with axis inclined to one of the reference planes and with axis inclined to both reference planes.

#### Module 3

Sections of Solids: Sections of Prisms, Pyramids, Cone, Cylinder with axis in vertical position and cut by different section planes. True shape of the sections. Also locating the section plane when the true shape of the section is given.

Development of Surfaces: Development of surfaces of the above solids and solids cut by different section planes. Also finding the shortest distance between two points on the surface.

#### Module 4

Isometric Projection: Isometric View and Projections of Prisms, Pyramids, Cone , Cylinder, Frustum of Pyramid, Frustum of Cone, Sphere, Hemisphere and their combinations.

#### Module 5

Perspective Projection: Perspective projection of Prisms and Pyramids with axis perpendicular to the ground plane, axis perpendicular to picture plane.

Conversion of Pictorial Views: Conversion of pictorial views into orthographic views.

### SECTION B

*(To be conducted in CAD Lab)*

Introduction to Computer Aided Drawing: Role of CAD in design and development of new products, Advantages of CAD. Creating two dimensional drawing with dimensions using suitable software. (Minimum 2 exercises mandatory)

Introduction to Solid Modelling: Creating 3D models of various components using suitable modelling software. (Minimum 2 exercises mandatory)

**Text Books**

1. Bhatt, N.D., Engineering Drawing, Charotar Publishing House Pvt. Ltd.
2. John, K.C. Engineering Graphics, Prentice Hall India Publishers.

**Reference Books**

1. Anilkumar, K.N., Engineering Graphics, Adhyuth narayan Publishers
2. Agrawal, B. And Agrawal, C.M., Engineering Drawing, Tata McGraw Hill Publishers.
3. Benjamin, J., Engineering Graphics, Pentex Publishers- 3<sup>rd</sup> Edition, 2017
4. Duff, J.M. and Ross, W.A., Engineering Design and Visualisation, Cengage Learning.
5. Kulkarni, D.M., Rastogi, A.P. and Sarkar, A.K., Engineering Graphics with AutoCAD, PHI.
6. Luzaddff, W.J. and Duff, J.M., Fundamentals of Engineering Drawing, PHI.
7. Varghese, P.I., Engineering Graphics, V I P Publishers
8. Venugopal, K., Engineering Drawing and Graphics, New Age International Publishers.

**Course Contents and Lecture Schedule**

No	SECTION A	No. of Hours
1	<b>MODULE I</b>	
1.1	Introduction to graphics, types of lines, Dimensioning	1
1.2	Concept of principle planes of projection, different quadrants, locating points on different quadrants	2
1.3	Projection of lines, inclined to one plane. Lines inclined to both planes, trapezoid method of solving problems on lines.	2
1.4	Problems on lines using trapezoid method	2
1.5	Line rotation method of solving, problems on line rotation method	2
2	<b>MODULE II</b>	
2.1	Introduction of different solids, Simple position plan and elevation of solids	2
2.2	Problems on views of solids inclined to one plane	2
2.3	Problems on views of solids inclined to both planes	2
2.4	Practice problems on solids inclined to both planes	2

3	<b>MODULE III</b>	
3.1	Introduction to section planes. AIP and AVP. Principle of locating cutting points and finding true shape	2
3.2	Problems on sections of different solids	2
3.3	Problems when the true shape is given	2
3.4	Principle of development of solids, sectioned solids	2
4	<b>MODULE IV</b>	
4.1	Principle of Isometric View and Projection, Isometric Scale. Problems on simple solids	2
4.2	Isometric problems on Frustum of solids, Sphere and Hemisphere	2
4.3	Problems on combination of different solids	2
5	<b>MODULE V</b>	
5.1	Introduction to perspective projection, different planes, station point etc. Perspective problems on pyramids	2
5.2	Perspective problems on prisms	2
5.3	Practice on conversion of pictorial views into orthographic views	2
	<b>SECTION B</b> <i>(To be conducted in CAD lab)</i>	
1	Introduction to CAD and software. Familiarising features of 2D software. Practice on making 2D drawings	2
2	Practice session on 2D drafting	2
3	Introduction to solid modelling and software	2
4	Practice session on 3D modelling	2



COURSE CODE	COURSE NAME	CATEGORY	L	T	P	CREDITS
22EST206	BASICS OF CIVIL & MECHANICAL ENGINEERING	ES	4	0	0	4

**Preamble:**

Objective of this course is to provide an insight and inculcate the essentials of Civil Engineering discipline to the students of all branches of Engineering and to provide the students an illustration of the significance of the Civil Engineering Profession in satisfying the societal needs.

To introduce the students to the basic principles of mechanical engineering

**Prerequisite:** NIL

**Course Outcomes:** After completion of the course, the student will be able to

<b>CO 1</b>	Recall the role of civil engineer in society and to relate the various disciplines of Civil Engineering.
<b>CO 2</b>	Explain different types of buildings, building components, building materials and building construction
<b>CO 3</b>	Describe the importance, objectives and principles of surveying.
<b>CO 4</b>	Summarise the basic infrastructure services MEP, HVAC, elevators, escalators and ramps
<b>CO 5</b>	Discuss the Materials, energy systems, water management and environment for green buildings.
<b>CO 6</b>	Analyse thermodynamic cycles and calculate its efficiency
<b>CO 7</b>	Illustrate the working and features of IC Engines
<b>CO 8</b>	Explain the basic principles of Refrigeration and Air Conditioning
<b>CO 9</b>	Describe the working of hydraulic machines
<b>CO 10</b>	Explain the working of power transmission elements
<b>CO 11</b>	Describe the basic manufacturing, metal joining and machining processes

**Mapping of course outcomes with program outcomes**

	PO 1	PO 2	PO 3	PO 4	PO 5	PO 6	PO 7	PO 8	PO 9	PO 10	PO 11	PO 12
<b>CO1</b>	3	-	-	-	-	3	2	2	-	-	-	-
<b>CO2</b>	3	2	-	1	3	-	-	3	-	-	-	-
<b>CO3</b>	3	2	-	-	3	-	-	-	2	-	-	-

CO4	3	2	-	-	3	-	-	-	2	-	-	-
CO5	3	2	-	-	3	2	3	-	2	-	-	-
CO6	3	2										
CO7	3	1										
CO8	3	1										
CO9	3	2										
CO10	3	1										
CO11	3											

### Assessment Pattern

Bloom's Category	Basic Civil Engineering			Basic Mechanical Engineering		
	Continuous Assessment		End Semester Examination (marks)	Continuous Assessment		End Semester Examination (marks)
	Test 1 marks	Test 2 marks		Test 1 marks	Test 2 marks	
Remember	5	5	10	7.5	7.5	15
Understand	20	20	40	12.5	12.5	25
Apply				5	5	10
Analyse						
Evaluate						
Create						

### Mark distribution

Total Marks	CIE (Marks)	ESE (Marks)	ESE Duration
150	50	100	3 hours

### Continuous Internal Evaluation Pattern:

Attendance	: 10 marks
Continuous Assessment Test (2 numbers)	: 25 marks
Assignment/Quiz/Course project	: 15 marks

### End Semester Examination Pattern:

There will be two parts; Part I – Basic Civil Engineering and Part II – Basic Mechanical Engineering. Part I and PART II carries 50 marks each. For the end semester examination, part I contain 2 parts -

Part A and Part B. Part A contain 5 questions carrying 4 marks each (not exceeding 2 questions from each module). Part B contains 2 questions from each module out of which one to be answered. Each question carries 10 mark and can have maximum 2 sub-divisions. The pattern for end semester examination for part II is same as that of part I. **However, student should answer both part I and part 2 in separate answer booklets.**

**Course Level Assessment Questions:**

**Course Outcome CO1:** *To recall the role of civil engineer in society and to relate the various disciplines of Civil Engineering.*

1. Explain relevance of Civil engineering in the overall infrastructural development of the country.  
Course outcome 2 (CO2) (One question from each module and not more than two)

*Explain different types of buildings, building components, building materials and building construction*

1. Discuss the difference between plinth area and carpet area.

Course outcome 3 (CO3) (One question from each module and not more than two)

*Describe the importance, objectives and principles of surveying.*

1. Explain the importance of surveying in Civil Engineering

Course outcome 4 (CO4) (One question from each module and not more than two)

*Summarise the basic infrastructure services MEP, HVAC, elevators, escalators and ramps*

1. Explain the civil engineering aspects of elevators, escalators and ramps in buildings

Course outcome 5 (CO5) (One question from each module and not more than two)

*Discuss the Materials, energy systems, water management and environment for green buildings.*

1. Discuss the relevance of Green building in society

**Section II** *Answer any 1 full question from each module. Each full question carries 10 marks*

**Course Outcome 1 (CO1)** (Two full question from each module and each question can have maximum 2 sub-divisions)

*To recall the role of civil engineer in society and to relate the various disciplines of Civil Engineering*

**CO Questions**

1. **a** List out the types of building as per occupancy. Explain any two, each in about five sentences.  
**b.** Discuss the components of a building with a neat figure.
2. **a.** What are the major disciplines of civil engineering and explain their role in the infrastructural framework.

b. Explain the role of NBC, KBR & CRZ norms in building rules and regulations prevailing in our country.

**Course Outcome 2 (CO2) & Course Outcome 3 (CO3) (Two full question from each module and each question can have maximum 2 sub-divisions)**

*Explain different types of buildings, building components, building materials and building construction & Describe the importance, objectives and principles of surveying.*

**CO Questions**

1. a. What are the different kinds of cement available and what is their use.  
b. List the properties of good building bricks. Explain any five.
2. a. List and explain any five modern construction materials used for construction.  
b. Explain the objectives and principles of surveying

**Course outcome 4 (CO4) & Course outcome 5 (CO5) (Two full question from each module and each question can have maximum 2 sub-divisions)**

*Summarise the basic infrastructure services MEP, HVAC, elevators, escalators and ramps & Discuss the Materials, energy systems, water management and environment for green buildings.*

**CO Questions**

1. a. Draw the elevation and plan of one brick thick wall with English bond  
b. Explain the energy systems and water management in Green buildings
  
2. a. Draw neat sketch of the following foundations: (i) Isolated stepped footing;  
(ii) Cantilever footing; and (iii) Continuous footing.  
  
b. Discuss the civil engineering aspect of MEP and HVAC in a commercial building

**Course Outcome 6 (CO6):**

1. In an air standard Otto cycle the compression ratio is 7 and compression begins at 35°C, 0.1 MPa. The maximum temperature of the cycle is 1100°C. Find
  - i) Heat supplied per kg of air,
  - ii) Work done per kg of air,
  - iii) Cycle efficiencyTake  $C_p = 1.005 \text{ kJ/kgK}$  and  $C_v = 0.718 \text{ kJ/kgK}$
2. A Carnot cycle works with adiabatic compression ratio of 5 and isothermal expansion ratio of 2. The volume of air at the beginning of isothermal expansion is  $0.3 \text{ m}^3$ . If the maximum temperature and pressure is limited to 550K and 21 bar, determine the minimum temperature in the cycle and efficiency of the cycle.
3. In an ideal diesel cycle, the temperature at the beginning and end of compression is 65°C and 620°C respectively. The temperature at the beginning and end of the expansion is 1850°C and 850°C. Determine the ideal efficiency of the cycle.

4. Explain the concepts of CRDI and MPFI in IC Engines.

**Course Outcome 7 (CO7)**

1. With the help of a neat sketch explain the working of a 4 stroke SI engine
2. Compare the working of 2 stroke and 4 stroke IC engines
3. Explain the classification of IC Engines.

**Course Outcome 8(CO8):**

1. Explain the working of vapour compression refrigeration system.
2. With the help of suitable sketch explain the working of a split air conditioner.
3. Define: COP, specific humidity, relative humidity and dew point temperature.

**Course Outcome 9 (CO9):**

1. Explain the working of a single stage centrifugal pump with sketches.
2. With the help of a neat sketch, explain the working of a reciprocating pump.
3. A turbine is to operate under a head of 25 m at 200 rpm. The discharge is  $9 \text{ m}^3/\text{s}$ . If the overall efficiency of the turbine is 90%. Determine the power developed by the turbine.

**Course Outcome 10 (CO10):**

1. Explain the working of belt drive and gear drive with the help of neat sketches
2. Explain a single plate clutch.
3. Sketch different types of gear trains and explain.

**Course Outcome 11 (CO11):**

1. Describe the operations which can be performed using drilling machine.
2. Explain the functions of runners and risers used in casting.
3. With a neat sketch, explain the working and parts of a lathe.

**Model Question Paper**

**QP CODE: EST120**

page:3

Reg No: \_\_\_\_\_

Name: \_\_\_\_\_

**APJ ABDUL KALAM TECHNOLOGICAL UNIVERSITY FIRST SEMESTER B.TECH DEGREE EXAMINATION,  
MONTH & YEAR**

**Course Code: EST 120**

**Course Name: BASICS OF CIVIL AND MECHANICAL ENGINEERING**

Max. Marks: 100

Duration: 3 hours

**Answer both part I and part 2 in separate answer booklets**

**PART I: BASIC CIVIL ENGINEERING**

**PART A**

(Answer all questions. Each question carries 4 marks)

1. Explain relevance of Civil engineering in the overall infrastructural development of the country.
2. Discuss the difference between plinth area and carpet area.
3. Explain different types of steel with their properties.
4. What are the different kinds of cement available and what is their use?
5. Define bearing capacity of soil.

(5 x 4 = 20)

**Part B**

Answer one full question from each module.

**MODULE I**

- 6a. List out the types of building as per occupancy. Explain any two, each in about five sentences. (5)
- b. Discuss the components of a building with a neat figure. (5)

**OR**

- 7a. What are the major disciplines of civil engineering and explain their role in the infrastructural framework. (5)
- b. Explain the role of NBC, KBR & CRZ norms in building rules and regulations prevailing in our country. (5)

**MODULE II**

- 8a. What are the different kinds of cement available and what is their use. (5)
- b. List the properties of good building bricks. Explain any five. (5)

**OR**

- 9a. List and explain any five modern construction materials used for construction. (5)
- b. Explain the objectives and principles of surveying (5)

**MODULE III**

- 10a. Draw the elevation and plan of one brick thick wall with English bond (5)
- b. Explain the energy systems and water management in Green buildings (5)

**OR**

- 11a. Draw neat sketch of the following foundations: (i) Isolated stepped footing; (ii) Cantilever footing; and (iii) Continuous footing. (5)
- b. Discuss the civil engineering aspect of MEP and HVAC in a commercial building (5)

[10 x 3 = 30]

## PART II: BASIC MECHANICAL ENGINEERING

### PART A

Answer all questions. Each question carries 4 marks

1. Sketch the P-v and T-s diagram of a Carnot cycle and List the processes.
2. Illustrate the working of an epicyclic gear train.
3. Explain cooling and dehumidification processes.
4. Differentiate between soldering and brazing.
5. Explain the principle of Additive manufacturing.

4 x 5 = 20 marks

### Part B

Answer one full question from each module.

#### MODULE I

6. In an air standard Otto cycle the compression ratio is 7 and compression begins at 35°C, 0.1MPa. The maximum temperature of the cycle is 1100°C. Find
- i) Heat supplied per kg of air,
  - ii) Work done per kg of air,
  - iii) Cycle efficiency

Take  $C_p = 1.005 \text{ kJ/kgK}$  and  $C_v = 0.718 \text{ kJ/kgK}$

10 marks

#### OR

7. a) Explain the working of a 4 stroke SI engine with neat sketches. 7 marks  
b) Explain the fuel system of a petrol engine. 3 marks

#### MODULE II

8. a) Explain the working of a vapour compression system with help of a block diagram. 7 marks  
b) Define: Specific humidity, relative humidity and dew point temperature. 3 marks

#### OR

9. With the help of a neat sketch, explain the working of a centrifugal pump. 10 marks

#### MODULE III

10. Explain the two high, three high, four high and cluster rolling mills with neat sketches. 10 marks

#### OR

11. a) Describe the arc welding process with a neat sketch. 6 marks  
b) Differentiate between up-milling and down-milling operations. 4 marks

## SYLLABUS

### Module 1

**General Introduction to Civil Engineering:** Relevance of Civil Engineering in the overall infrastructural development of the country. Responsibility of an engineer in ensuring the safety of built environment. Brief introduction to major disciplines of Civil Engineering like Transportation Engineering, Structural Engineering, Geo-technical Engineering, Water Resources Engineering and Environmental Engineering.

**Introduction to buildings:** Types of buildings, selection of site for buildings, components of a residential building and their functions.

**Building rules and regulations:** Relevance of NBC, KBR & CRZ norms (brief discussion only).

**Building area:** Plinth area, built up area, floor area, carpet area and floor area ratio for a building as per KBR.

### Module 2

**Surveying:** Importance, objectives and principles.

**Construction materials,** Conventional construction materials: types, properties and uses of building materials: bricks, stones, cement, sand and timber

**Cement concrete:** Constituent materials, properties and types.

Steel: Steel sections and steel reinforcements, types and uses.

**Modern construction materials:-** Architectural glass, ceramics, Plastics, composite materials, thermal and acoustic insulating materials, decorative panels, waterproofing materials. Modern uses of gypsum, pre-fabricated building components (brief discussion only).

### Module 3

**Building Construction:** Foundations: Bearing capacity of soil (definition only), functions of foundations, types – shallow and deep (brief discussion only). Load bearing and framed structures (concept only).

**Brick masonry:** - Header and stretcher bond, English bond & Flemish bond random rubble masonry.

**Roofs and floors:** - Functions, types; flooring materials (brief discussion only).

**Basic infrastructure services:** MEP, HVAC, elevators, escalators and ramps (Civil Engineering aspects only), fire safety for buildings.

**Green buildings:-** Materials, energy systems, water management and environment for green buildings. (brief discussion only).

### Module 4

**Analysis of thermodynamic cycles:** Carnot, Otto, Diesel cycles, Derivation of efficiency of these cycles, Problems to calculate heat added, heat rejected, net work and efficiency. IC Engines: CI, SI, 2-Stroke, 4-Stroke engines. Listing the parts of different types of IC Engines. Efficiencies of IC Engines(Definitions only), Air, Fuel, cooling and lubricating systems in SI and CI Engines, CRDI, MPFI. Concept of hybrid engines.



### Module 5

**Refrigeration:** Unit of refrigeration, reversed Carnot cycle, COP, vapour compression cycle (only description and no problems); Definitions of dry, wet & dew point temperatures, specific humidity and relative humidity, Cooling and dehumidification, Layout of unit and central air conditioners.

Description about working with sketches of: Reciprocating pump, Centrifugal pump, Pelton turbine, Francis turbine and Kaplan turbine. Overall efficiency, Problems on calculation of input and output power of pumps and turbines (No velocity triangles)

Description about working with sketches of: Belt and Chain drives, Gear and Gear trains, Single plate clutches.

### Module 6

**Manufacturing Process:** Basic description of the manufacturing processes – Sand Casting, Forging, Rolling, Extrusion and their applications.

Metal Joining Processes: List types of welding, Description with sketches of Arc Welding, Soldering and Brazing and their applications

Basic Machining operations: Turning, Drilling, Milling and Grinding.

Description about working with block diagram of: Lathe, Drilling machine, Milling machine, CNC Machine. Principle of CAD/CAM, Rapid and Additive manufacturing.

#### Text Books:

1. Rangwala, S. C., Essentials of Civil Engineering, Charotar Publishing House
2. Mckay, W.B. and Mckay, J. K., Building Construction, Volumes 1 to 4, Pearson India Education Services

#### References Books:

1. Chen W.F and Liew J Y R (Eds), The Civil Engineering Handbook. II Edition CRC Press (Taylor and Francis)
2. Chudley, R and Greeno R, Building construction handbook, Addison Wesley, Longman group, England
3. Chudley, R, Construction Technology, Vol. I to IV, Longman group, England Course Plan
4. Kandy A A, Elements of Civil Engineering, Charotar Publishing house
5. Mamlouk, M. S., and Zaniewski, J. P., Materials for Civil and Construction Engineering, Pearson Publishers
6. Rangwala S.C and Dalal K B Building Construction Charotar Publishing house
7. Clifford, M., Simmons, K. and Shipway, P., An Introduction to Mechanical Engineering Part I - CRC Press
8. Roy and Choudhary, Elements of Mechanical Engineering, Media Promoters & Publishers Pvt. Ltd., Mumbai.
9. Sawhney, G. S., Fundamentals of Mechanical Engineering, PHI
10. G Shanmugam, M S Palanichamy, Basic Civil and Mechanical Engineering, McGraw Hill Education; First edition, 2018
11. Benjamin, J., Basic Mechanical Engineering, Pentex Books, 9<sup>th</sup> Edition, 2018
12. Balachandran, P. Basic Mechanical Engineering, Owl Books

**Course Contents and Lecture Schedule:**

No	Topic	Course outcomes addressed	No. of Lectures
<b>1</b>	<b>Module I</b>		<b>Total: 7</b>
1.1	<i>General Introduction to Civil Engineering:</i> Relevance of Civil Engineering in the overall infrastructural development of the country. Responsibility of an engineer in ensuring the safety of built environment.	CO1	1
1.2	Brief introduction to major disciplines of Civil Engineering like Transportation Engineering, Structural Engineering, Geo-technical Engineering, Water Resources Engineering and Environmental Engineering.	CO1	2
1.3	<i>Introduction to buildings:</i> Types of buildings, selection of site for buildings, components of a residential building and their functions.	CO2	2
1.4	<i>Building rules and regulations:</i> Relevance of NBC, KBR & CRZ norms (brief discussion only)	CO2	1
1.5	<i>Building area:</i> Plinth area, built up area, floor area, carpet area and floor area ratio for a building as per KBR.	CO2	1
<b>2</b>	<b>Module 2</b>		<b>Total: 7</b>
2.1	<i>Surveying:</i> Importance, objectives and principles.	CO3	1
2.2	Bricks: - Classification, properties of good bricks, and tests on bricks	CO2	1
2.3	Stones: - <i>Qualities</i> of good stones, types of stones and their uses. Cement: - Good qualities of cement, types of cement and their uses.	CO2	1
2.4	Sand: - Classification, qualities of good sand and sieve analysis (basics only). Timber: - Characteristics, properties and uses.	CO2	1
2.5	Cement concrete: - Constituent materials, properties and types, Steel: - Steel sections and steel reinforcements, types and uses.	CO2	1

2.6	Modern construction materials: - Architectural glass, ceramics, plastics, composite materials, thermal and acoustic insulating materials, decorative panels, waterproofing materials, modern uses of gypsum, pre-fabricated building components (brief discussion only)	CO2	2
<b>3</b>	<b>Module 3</b>		<b>Total: 7</b>
3.1	Foundations: - Bearing capacity of soil (definition only), functions of foundations, types – shallow and deep (brief discussion only). Brick masonry: - Header and stretcher bond, English bond & Flemish bond– elevation and plan (one & one and a half brick wall only). Random rubble masonry.	CO2	2
3.2	Roofs: Functions, types; roofing materials (brief discussion only) Floors: Functions, types; flooring materials (brief discussion only)	CO2	2
3.3	<i>Basic infrastructure services:</i> MEP, HVAC, Elevators, escalators and ramps (Civil Engineering aspects only) fire safety for buildings	CO4	2
3.4	<i>Green buildings:-</i> Materials, energy systems, water management and environment for green buildings. (brief discussion only)	CO5	1
<b>4</b>	<b>MODULE 4</b>		
4.1	Analysis of thermodynamic cycles: Carnot, Otto, and Diesel cycle- Derivation of efficiency of these cycles, Problems to calculate heat added, heat rejected, net work and efficiency		4
4.2	IC Engines: CI, SI, 2-Stroke, 4-Stroke engines. Listing the parts of different types of IC Engines, efficiencies of IC Engines(Description only)		2
4.3	Air, Fuel, cooling and lubricating systems in SI and CI Engines, CRDI, MPFI. Concept of hybrid engines		2
<b>5</b>	<b>MODULE 5</b>		
5.1	Refrigeration: Unit of refrigeration, reversed Carnot cycle, COP, vapour compression cycle (only description and no problems)		1
5.2	Definitions of dry, wet & dew point temperatures, specific humidity and relative humidity, Cooling and dehumidification, Layout of unit and central air conditioners.		1

5.3	Description about working with sketches : Reciprocating pump, Centrifugal pump, Pelton turbine, Francis turbine and Kaplan turbine. Overall efficiency, Problems on calculation of input and output power of pumps and turbines (No velocity triangles)	4
5.4	Description about working with sketches of: Belt and Chain drives, Gear and Gear trains, Single plate clutches	3
6	<b>MODULE 6</b>	
6.1	Manufacturing Process: Basic description of the manufacturing processes – Sand Casting, Forging, Rolling, Extrusion and their applications.	2
6.2	Metal Joining Processes :List types of welding, Description with sketches of Arc Welding, Soldering and Brazing, and their applications	1
6.3	Basic Machining operations: Turning, Drilling, Milling and Grinding  Description about working with block diagrams of: Lathe, Drilling machine, Milling machine, CNC Machine	3
6.4	Principle of CAD/CAM, Rapid and Additive manufacturing	1

COURSE CODE	COURSE NAME	CATEGORY	L	T	P	CREDITS
22EST207	BASICS OF ELECTRICAL & ELCTRONICS ENGINEERING	ES	4	0	0	4

**Preamble:**

This course aims to (1) equip the students with an understanding of the fundamental principles of electrical engineering(2) provide an overview of evolution of electronics, and introduce the working principle and examples of fundamental electronic devices and circuits (3) provide an overview of evolution of communication systems, and introduce the basic concepts in radio communication.

**Prerequisite:** Physics and Mathematics (Pre-university level)

**Course Outcomes:** After the completion of the course the student will be able to

<b>CO 1</b>	Apply fundamental concepts and circuit laws to solve simple DC electric circuits
<b>CO 2</b>	Develop and solve models of magnetic circuits
<b>CO 3</b>	Apply the fundamental laws of electrical engineering to solve simple ac circuits in steady state
<b>CO 4</b>	Describe working of a voltage amplifier
<b>CO 5</b>	Outline the principle of an electronic instrumentation system
<b>CO 6</b>	Explain the principle of radio and cellular communication

**Mapping of course outcomes with program outcomes**

	PO 1	PO 2	PO 3	PO 4	PO 5	PO 6	PO 7	PO 8	PO 9	PO 10	PO 11	PO 12
<b>CO 1</b>	3	1	-	-	-	-	-	-	-	-	-	2
<b>CO 2</b>	3	1	-	-	-	-	-	-	-	-	-	2
<b>CO 3</b>	3	1	-	-	-	-	-	-	-	-	-	2
<b>CO 4</b>	2	-	-	-	-	-	-	-	-	-	-	-
<b>CO 5</b>	2	-	-	-	-	-	-	-	-	-	-	2
<b>CO 6</b>	2	-	-	-	-	-	-	-	-	-	-	2

**Assessment Pattern**

Bloom's Category	Basic Electrical Engineering			Basic Electronics Engineering		
	Continuous Assessment Tests		End Semester Examination (Marks)	Continuous Assessment Tests		End Semester Examination (Marks)
	Test 1 (Marks)	Test 2 (Marks)		Test 1 (Marks)	Test 2 (Marks)	
Remember	0	0	10	10	10	20
Understand	12.5	12.5	20	15	15	30
Apply	12.5	12.5	20			
Analyse						
Evaluate						
Create						

### Mark distribution

Total Marks	CIE marks	ESE marks	ESE Duration
150	50	100	3 hours

### Continuous Internal Evaluation Pattern:

Attendance	: 10 marks
Continuous Assessment Test (2 numbers)	: 25 marks
Assignment/Quiz/Course project	: 15 marks

**End Semester Examination Pattern:** There will be two parts; Part I – Basic Electrical Engineering and Part II – Basic Electronics Engineering. Part I and PART II carries 50 marks each. For the end semester examination, part I contain 2 parts - Part A and Part B. Part A contain 5 questions carrying 4 marks each (not exceeding 2 questions from each module). Part B contains 2 questions from each module out of which one to be answered. Each question carries 10 mark and can have maximum 2 sub-divisions. The pattern for end semester examination for part II is same as that of part I. **However, student should answer both part I and part 2 in separate answer booklets.**

### Course Level Assessment Questions

#### Course Outcome 1 (CO1):

1. Solve problems based on current division rule.
2. Solve problems with Mesh/node analysis.
3. Solve problems on Wye-Delta Transformation.

#### Course Outcome 2 (CO2):

1. Problems on series magnetic circuits
2. Problems on parallel magnetic circuits
3. Problems on composite magnetic circuits

#### 4. Course Outcome 3 (CO3):

1. problems on self inductance, mutual inductance and coefficient of coupling
2. problems on rms and average values of periodic waveforms
3. problems on series ac circuits
4. Compare star and Delta connected 3 phase AC systems.

#### Course Outcome 4 (CO4): Describe working of a voltage amplifier

1. What is the need of voltage divider biasing in an RC coupled amplifier?

2. Define operating point in the context of a BJT amplifier.
3. Why is it required to have a voltage amplifier in a public address system?

**Course Outcome 5 (CO5):** Outline the principle of an electronic instrumentation system

1. Draw the block diagram of an electronic instrumentation system.
2. What is a transducer?
3. Explain the working principle of operation of digital multimeter.

**Course Outcome 6 (CO6):** Explain the principle of radio and cellular communication

1. What is the working principle of an antenna when used in a radio transmitter?
2. What is the need of two separate sections RF section and IF section in a super heterodyne receiver?
3. What is meant by a cell in a cellular communication?

### Model Question Paper

QP CODE:

Pages: 3

Reg No.: \_\_\_\_\_

Name: \_\_\_\_\_

**APJ ABDUL KALAM TECHNOLOGICAL UNIVERSITY FIRST SEMESTER B.TECH DEGREE EXAMINATION,  
MONTH & YEAR**

*Course Code: EST 130*

*Course Name: BASICS OF ELECTRICAL AND ELECTRONICS ENGINEERING*

Max. Marks: 100

Duration: 3 hours

**Answer both part I and part 2 in separate answer booklets**

#### PART I

#### BASIC ELECTRICAL ENGINEERING

#### PART A

*Answer all questions; each question carries 4 marks.*

1. Calculate the current through the  $4\Omega$  resistor in the circuit shown, applying current division rule:

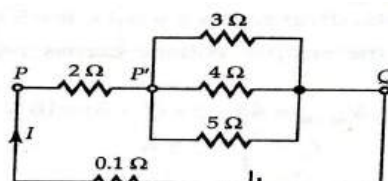

2. Calculate the RMS and average values of a purely sinusoidal current having peak value 15A.
3. An alternating voltage of  $(80+j60)V$  is applied to an RX circuit and the current flowing through the circuit is  $(-4+j10)A$ . Calculate the impedance of the circuit in rectangular and polar forms. Also determine if X is inductive or capacitive.
4. Derive the relation between line and phase values of voltage in a three phase star connected system.
5. Compare electric and magnetic circuits. (5x4=20)

**PART B**

*Answer one question from each module; each question carries 10 marks.*

**Module 1**

6. . Calculate the node voltages in the circuit shown, applying node analysis:

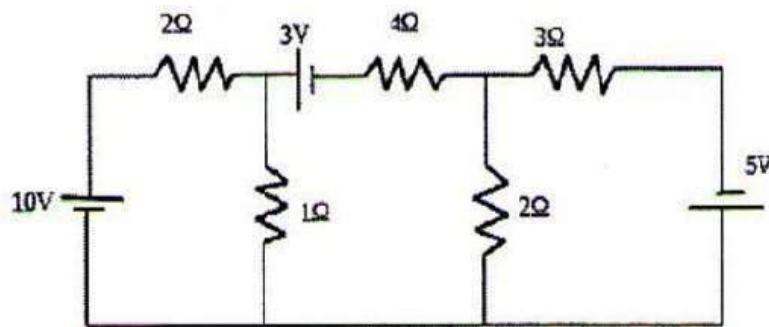

7. (a) State and explain Kirchhoff's laws. (4 marks)

- (b) Calculate the current through the galvanometer (G) in the circuit shown:

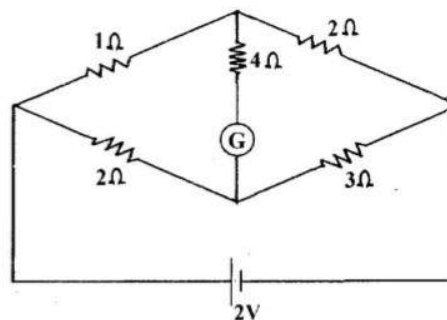

(6 marks)



### Module 2

8. (a) State and explain Faraday's laws of electromagnetic induction with examples. (4 marks)
- (b) Differentiate between statically and dynamically induced emf. A conductor of length 0.5m moves in a uniform magnetic field of flux density 1.1T at a velocity of 30m/s. Calculate the emf induced in the conductor if the direction of motion of the conductor is inclined at  $60^\circ$  to the direction of field. (6 marks)
9. (a) Derive the amplitude factor and form factor of a purely sinusoidal waveform. (5 marks)
- (b) A current wave is made up of two components-a 5A dc component and a 50Hz ac component, which is a sinusoidal wave with a peak value of 5A. Sketch the resultant waveform and determine its RMS and average values. (5 marks)

### Module 3

10. Draw the power triangle and define active, reactive and apparent powers in ac circuits. Two coils A and B are connected in series across a 240V, 50Hz supply. The resistance of A is  $5\Omega$  and the inductance of B is 0.015H. If the input from the supply is 3kW and 2kVAR, find the inductance of A and the resistance of B. Also calculate the voltage across each coil.
11. A balanced three phase load consists of three coils each having resistance of  $4\Omega$  and inductance 0.02H. It is connected to a 415V, 50Hz, 3-phase ac supply. Determine the phase voltage, phase current, power factor and active power when the loads are connected in (i) star (ii) delta.

(3x10=30)

### PART II

#### BASIC ELECTRONICS ENGINEERING

### PART A

*Answer all questions; each question carries 4 marks.*

1. Give the specifications of a resistor. The colour bands marked on a resistor are Blue, Grey, Yellow and Gold. What are the minimum and maximum resistance values expected from that resistance?
2. What is meant by avalanche breakdown?
3. Explain the working of a full-wave bridge rectifier.
4. Discuss the role of coupling and bypass capacitors in a single stage RC coupled amplifier.
5. Differentiate AM and FM communication systems.

(5x4=20)

**PART B**

***Answer one question from each module; each question carries 10 marks.***

**Module 4**

6. a) Explain with diagram the principle of operation of an NPN transistor. (5)  
b) Sketch and explain the typical input-output characteristics of a BJT when connected in common emitter configuration. (5)

**OR**

7. a) Explain the formation of a potential barrier in a P-N junction diode. (5)  
b) What do you understand by Avalanche breakdown? Draw and explain the V-I characteristics of a P-N junction and Zener diode. (5)

**Module 5**

8. a) With a neat circuit diagram, explain the working of an RC coupled amplifier. (6)  
b) Draw the frequency response characteristics of an RC coupled amplifier and state the reasons for the reduction of gain at lower and higher frequencies. (4)

**OR**

9. a) With the help of block diagram, explain how an electronic instrumentation system. (6)  
b) Explain the principle of an antenna. (4)

**Module 6**

10. a) With the help of a block diagram, explain the working of Super heterodyne receiver. (6)  
b) Explain the importance of antenna in a communication system. (4)

**OR**

11. a) With neat sketches explain a cellular communication system. (5)  
b) Explain GSM communication with the help of a block diagram. (5)

*(3x10=30)*

## SYLLABUS

### MODULE 1: Elementary Concepts of Electric Circuits

**Elementary concepts of DC electric circuits:** Basic Terminology including voltage, current, power, resistance, emf; Resistances in series and parallel; Current and Voltage Division Rules; Capacitors & Inductors: V-I relations and energy stored. Ohms Law and Kirchhoff's laws-Problems; Star-delta conversion (resistive networks only-derivation not required)-problems.

**Analysis of DC electric circuits:** Mesh current method - Matrix representation - Solution of network equations. Node voltage methods-matrix representation-solution of network equations by matrix methods. Numerical problems.

### MODULE 2: Elementary Concepts of Magnetic circuits, Electromagnetic Induction and AC fundamentals

**Magnetic Circuits:** Basic Terminology: MMF, field strength, flux density, reluctance - comparison between electric and magnetic circuits- Series and parallel magnetic circuits with composite materials, numerical problems.

**Electromagnetic Induction:** Faraday's laws, problems, Lenz's law- statically induced and dynamically induced emfs - Self-inductance and mutual inductance, coefficient of coupling

**Alternating Current fundamentals:** Generation of alternating voltages-Representation of sinusoidal waveforms: frequency, period, Average, RMS values and form factor of waveforms-Numerical Problems.

### MODULE 3: AC Circuits

**AC Circuits:** Phasor representation of sinusoidal quantities. Trigonometric, Rectangular, Polar and complex forms. Analysis of simple AC circuits: Purely resistive, inductive & capacitive circuits; Inductive and capacitive reactance, concept of impedance. Average Power Power factor. Analysis of RL, RC and RLC series circuits-active, reactive and apparent power. Simple numerical problems.

**Three phase AC systems:** Generation of three phase voltages; advantages of three phase systems, star and delta connections (balanced only), relation between line and phase voltages, line and phase currents- Numerical problems

### MODULE 4

**Introduction to Semiconductor devices:** Evolution of electronics – Vacuum tubes to nano electronics. Resistors, Capacitors and Inductors (constructional features not required): types, specifications. Standard values, color coding. PN Junction diode: Principle of operation, V-I characteristics, principle of avalanche breakdown. Bipolar Junction Transistors: PNP and NPN structures, Principle of operation, relation between current gains in CE, CB and CC, input and output characteristics of common emitter configuration.

## MODULE 5

**Basic electronic circuits and instrumentation:** Rectifiers and power supplies: Block diagram description of a dc power supply, Working of a full wave bridge rectifier, capacitor filter (no analysis), working of simple zener voltage regulator. Amplifiers: Block diagram of Public Address system, Circuit diagram and working of common emitter (RC coupled) amplifier with its frequency response, Concept of voltage divider biasing. Electronic Instrumentation: Block diagram of an electronic instrumentation system.

## MODULE 6

**Introduction to Communication Systems:** Evolution of communication systems – Telegraphy to 5G. Radio communication: principle of AM & FM, frequency bands used for various communication systems, block diagram of super heterodyne receiver, Principle of antenna – radiation from accelerated charge. Mobile communication: basic principles of cellular communications, principle and block diagram of GSM.

### Text Books

1. D P Kothari and I J Nagrath, "Basic Electrical Engineering", Tata McGraw Hill, 2010.
2. D C Kulshreshtha, "Basic Electrical Engineering", Tata McGraw Hill, 2010.
3. ChinmoySaha, Arindham Halder and Debarati Ganguly, Basic Electronics - Principles and Applications, Cambridge University Press, 2018.
4. M.S.Sukhija and T.K.Nagsarkar, Basic Electrical and Electronics Engineering, Oxford University Press, 2012.
5. Wayne Tomasi and Neil Storey, A Textbook On Basic Communication and Information Engineering, Pearson, 2010.

### Reference Books

1. Del Toro V, "Electrical Engineering Fundamentals", Pearson Education.
2. T. K. Nagsarkar, M. S. Sukhija, "Basic Electrical Engineering", Oxford Higher Education.
3. Hayt W H, Kemmerly J E, and Durbin S M, "Engineering Circuit Analysis", Tata McGraw-Hill
4. Hughes, "Electrical and Electronic Technology", Pearson Education.
5. V. N. Mittle and Arvind Mittal, "Basic Electrical Engineering," Second Edition, McGraw Hill.
6. Parker and Smith, "Problems in Electrical Engineering", CBS Publishers and Distributors.
7. S. B. Lal Seksena and Kaustuv Dasgupta, "Fundamentals of Electrical Engineering", Cambridge University Press.
8. Anant Agarwal, Jeffrey Lang, Foundations of Analog and Digital Electronic Circuits, Morgan Kaufmann Publishers, 2005.
9. Bernard Grob, Basic Electronics, McGraw Hill.
10. A. Bruce Carlson, Paul B. Crilly, Communication Systems: An Introduction to Signals and Noise in Electrical Communication, Tata McGraw Hill, 5<sup>th</sup> Edition.

## COURSE CONTENTS AND LECTURE SCHEDULE

No	Topic	No. of Lectures
<b>1</b>	<b><i>Elementary Concepts of Electric Circuits</i></b>	
1.1	<p><b>Elementary concepts of DC electric circuits:</b></p> <p>Basic Terminology including voltage, current, power, resistance, emf; Resistances in series and parallel; Current and Voltage Division Rules; Capacitors &amp; Inductors: V-I relations and energy stored.</p> <p>Ohms Law and Kirchhoff's laws-Problems;</p> <p>Star-delta conversion (resistive networks only-derivation not required)-problems.</p>	<p>1</p> <p>2</p> <p>1</p>
1.2	<p><b>Analysis of DC electric circuits:</b> Mesh current method - Matrix representation - Solution of network equations.</p> <p>Node voltage methods-matrix representation-solution of network equations by matrix methods.</p> <p>Numerical problems.</p>	<p>1</p> <p>1</p> <p>2</p>
<b>2</b>	<b>Elementary Concepts of Magnetic circuits, Electromagnetic Induction and AC fundamentals</b>	
2.1	<p><b>Magnetic Circuits:</b> Basic Terminology: MMF, field strength, flux density, reluctance - comparison between electric and magnetic circuits-</p> <p>Series and parallel magnetic circuits with composite materials, numerical problems.</p>	<p>1</p> <p>2</p>
2.2	<p><b>Electromagnetic Induction:</b> Faraday's laws, problems, Lenz's law- statically induced and dynamically induced emfs -</p> <p>Self-inductance and mutual inductance, coefficient of coupling</p>	<p>1</p> <p>2</p>
2.3	<p><b>Alternating Current fundamentals:</b> Generation of alternating voltages- Representation of sinusoidal waveforms: frequency, period, Average, RMS values and form factor of waveforms-Numerical Problems.</p>	2
<b>3</b>	<b>AC Circuits</b>	

3.1	<p><b>AC Circuits:</b> Phasor representation of sinusoidal quantities. Trigonometric, Rectangular, Polar and complex forms.</p> <p>Analysis of simple AC circuits: Purely resistive, inductive &amp; capacitive circuits; Inductive and capacitive reactance, concept of impedance. Average Power, Power factor.</p> <p>Analysis of RL, RC and RLC series circuits-active, reactive and apparent power.</p> <p>Simple numerical problems.</p>	1 2 1 2
3.2	<p><b>Three phase AC systems:</b> Generation of three phase voltages; advantages of three phase systems, star and delta connections (balanced only), relation between line and phase voltages, line and phase currents- Numerical problems.</p>	2
<b>4</b>	<b>Introduction to Semiconductor devices</b>	
4.1	Evolution of electronics – Vacuum tubes to nano electronics (In evolutionary perspective only)	1
4.2	Resistors, Capacitors and Inductors: types, specifications. Standard values, color coding (No constructional features)	2
4.3	<b>PN Junction diode:</b> Principle of operation, V-I characteristics, principle of avalanche breakdown	2
4.4	<b>Bipolar Junction Transistors:</b> PNP and NPN structures, Principle of operation, relation between current gains in CE, CB and CC, input and output characteristics of common emitter configuration	3
<b>5</b>	<b>Basic electronic circuits and instrumentation</b>	
5.1	<b>Rectifiers and power supplies:</b> Block diagram description of a dc power supply, Working of a full wave bridge rectifier, capacitor filter (no analysis), working of simple zener voltage regulator	3
5.2	<b>Amplifiers:</b> Block diagram of Public Address system, Circuit diagram and working of common emitter (RC coupled) amplifier with its frequency response, Concept of voltage divider biasing	4
5.3	<b>Electronic Instrumentation:</b> Block diagram of an electronic instrumentation system	2
<b>6</b>	<b>Introduction to Communication Systems</b>	
6.1	Evolution of communication systems – Telegraphy to 5G	1

6.2	<b>Radio communication:</b> principle of AM & FM, frequency bands used for various communication systems, block diagram of super heterodyne receiver, Principle of antenna – radiation from accelerated charge	4
6.3	<b>Mobile communication:</b> basic principles of cellular communications, principle and block diagram of GSM.	2

#### **Suggested Simulation Assignments for Basic Electronics Engineering**

1. Plot V-I characteristics of Si and Ge diodes on a simulator
2. Plot Input and Output characteristics of BJT on a simulator
3. Implementation of half wave and full wave rectifiers
4. Simulation of RC coupled amplifier with the design supplied
5. Generation of AM signal

Note: The simulations can be done on open tools such as QUCS, KiCad, GNURadio or similar software to augment the understanding.

COURSE CODE	COURSE NAME	CATEGORY	L	T	P	CREDITS
22HUT208	PROFESSIONAL COMMUNICATION	MNC	2	0	2	--

**Preamble:** Clear, precise, and effective communication has become a *sine qua non* in today's information-driven world given its interdependencies and seamless connectivity. Any aspiring professional cannot but master the key elements of such communication. The objective of this course is to equip students with the necessary skills to listen, read, write, and speak so as to comprehend and successfully convey any idea, technical or otherwise, as well as give them the necessary polish to become persuasive communicators.

**Prerequisite:** None

**Course Outcomes:** After the completion of the course the student will be able to

<b>CO 1</b>	Develop vocabulary and language skills relevant to engineering as a profession
<b>CO 2</b>	Analyze, interpret and effectively summarize a variety of textual content
<b>CO 3</b>	Create effective technical presentations
<b>CO 4</b>	Discuss a given technical/non-technical topic in a group setting and arrive at generalizations/consensus
<b>CO 5</b>	Identify drawbacks in listening patterns and apply listening techniques for specific needs
<b>CO 6</b>	Create professional and technical documents that are clear and adhering to all the necessary conventions

#### Mapping of course outcomes with program outcomes

	PO 1	PO 2	PO 3	PO 4	PO 5	PO 6	PO 7	PO 8	PO 9	PO 10	PO 11	PO 12
<b>CO 1</b>										3		2
<b>CO 2</b>										1		3
<b>CO 3</b>						1			1	3		
<b>CO 4</b>										3		1
<b>CO 5</b>		1							2	3		
<b>CO 6</b>	1					1			1	3		

#### Mark distribution

Total Marks	CIE	ESE	ESE Duration
100	50	50	2 hours



### Continuous Internal Evaluation

#### Total Marks: 50

Attendance	: 10 marks
Regular assessment	: 25 marks
Series test (one test only, should include verbal aptitude for placement and higher studies, this test will be conducted for 50 marks and reduced to 15)	: 15 marks

#### Regular assessment

Project report presentation and Technical presentation through PPT	: 7.5 marks
Listening Test	: 5 marks
Group discussion/mock job interview	: 7.5 marks
Resume submission	: 5 marks

### End Semester Examination

Total Marks: 50, Time: 2 hrs.

### Course Level Assessment Questions

#### Course Outcome 1 (CO1):

1. List down the ways in which gestures affect verbal communication.
2. Match the words and meanings  
Ambiguous      promotion  
Bona fide      referring to whole  
Holistic      not clear  
Exaltation      genuine
3. Expand the following Compound Nouns - a. Water supply. b. Object recognition. c. Steam turbine

#### Course Outcome 2 (CO2)

1. Read the passage below and prepare notes:

*Mathematics, rightly viewed, possesses not only truth, but supreme beauty—a beauty cold and austere, like that of sculpture, without appeal to any part of our weaker nature, without the gorgeous trappings of painting or music, yet sublimely pure, and capable of a stern perfection such as only the greatest art can show. The true spirit of delight, the exaltation, the sense of being more than man, which is the touchstone of the highest excellence, is to be found in mathematics as surely as in poetry. What is best in mathematics deserves not merely to be learnt as a task, but to be assimilated as a part of daily thought, and brought again and again before the mind with ever-renewed encouragement. Real life is, to most men, a long second-best, a perpetual compromise between the ideal and the possible; but the world of pure reason knows no compromise, no practical limitations, no barrier to the creative activity embodying in splendid edifices the passionate aspiration after the perfect from which all great work springs. Remote from human passions, remote even from the pitiful facts of nature, the generations have gradually created an ordered cosmos, where pure thought can dwell as in its natural home, and where one, at least, of our nobler impulses can escape from the dreary exile of the actual world.*

*So little, however, have mathematicians aimed at beauty, that hardly anything in their work has had this conscious purpose. Much, owing to irrepressible instincts, which were better than avowed*

*beliefs, has been moulded by an unconscious taste; but much also has been spoilt by false notions of what was fitting. The characteristic excellence of mathematics is only to be found where the reasoning is rigidly logical: the rules of logic are to mathematics what those of structure are to architecture. In the most beautiful work, a chain of argument is presented in which every link is important on its own account, in which there is an air of ease and lucidity throughout, and the premises achieve more than would have been thought possible, by means which appear natural and inevitable. Literature embodies what is general in particular circumstances whose universal significance shines through their individual dress; but mathematics endeavours to present whatever is most general in its purity, without any irrelevant trappings.*

*How should the teaching of mathematics be conducted so as to communicate to the learner as much as possible of this high ideal? Here experience must, in a great measure, be our guide; but some maxims may result from our consideration of the ultimate purpose to be achieved.*

- From "On the teaching of mathematics" – Bertrand Russell

2. Enumerate the advantages and disadvantages of speed reading. Discuss how it can impact comprehension.

#### **Course Outcome 3(CO3):**

1. What are the key elements of a successful presentation?
2. Elucidate the importance of non-verbal communication in making a presentation
3. List out the key components in a technical presentation.

#### **Course Outcome 4 (CO4):**

1. Discuss: 'In today's world, being a good listener is more important than being a good Speaker.'
2. Listen to a video/live group discussion on a particular topic, and prepare a brief summary of the proceedings.
3. List the do's and don'ts in a group discussion.

#### **Course Outcome 5 (CO5):**

1. Watch a movie clip and write the subtitles for the dialogue.
2. What do you mean by barriers to effective listening? List ways to overcome each of these.
3. What are the different types of interviews? How are listening skills particularly important in Skype/telephonic interviews?

#### **Course Outcome 6 (CO6):**

1. Explain the basic structure of a technical report.
2. You have been offered an internship in a much sought-after aerospace company and are very excited about it. However, the dates clash with your series tests. Write a letter to the Manager – University Relations of the company asking them if they can change the dates to coincide with your vacation.
3. You work in a well-reputed aerospace company as Manager – University Relations. You are in charge of offering internships. A student has sent you a letter requesting you to change the dates allotted to him since he has series exams at that time. But there are no vacancies available during the period he has requested for. Compose an e-mail informing him of this and suggest that he try to arrange the matter with his college.

## **Syllabus**

### **Module 1**

Use of language in communication: Significance of technical communication Vocabulary Development: technical vocabulary, vocabulary used in formal letters/emails and reports, sequence words, misspelled words, compound words, finding suitable synonyms, paraphrasing, verbal analogies. Language Development: subject-verb agreement, personal passive voice, numerical adjectives, embedded sentences, clauses, conditionals, reported speech, active/passive voice.

Technology-based communication: Effective email messages, slide presentations, editing skills using software. Modern day research and study skills: search engines, repositories, forums such as Git Hub, Stack Exchange, OSS communities (MOOC, SWAYAM, NPTEL), and Quora; Plagiarism

### **Module 2**

Reading, Comprehension, and Summarizing: Reading styles, speed, valuation, critical reading, reading and comprehending shorter and longer technical articles from journals, newspapers, identifying the various transitions in a text, SQ3R method, PQRS method, speed reading. Comprehension: techniques, understanding textbooks, marking and underlining, Note-taking: recognizing non-verbal cues.

### **Module 3**

Oral Presentation: Voice modulation, tone, describing a process, Presentation Skills: Oral presentation and public speaking skills, business presentations, Preparation: organizing the material, self-Introduction, introducing the topic, answering questions, individual presentation practice, presenting visuals effectively.

Debate and Group Discussions: introduction to Group Discussion (GD), differences between GD and debate; participating GD, understanding GD, brainstorming the topic, questioning and clarifying, GD strategies, activities to improve GD skills

### **Module 4**

Listening and Interview Skills Listening: Active and Passive listening, listening: for general content, to fill up information, intensive listening, for specific information, to answer, and to understand. Developing effective listening skills, barriers to effective listening, listening to longer technical talks, listening to classroom lectures, talks on engineering /technology, listening to documentaries and making notes, TED talks.

Interview Skills: types of interviews, successful interviews, interview etiquette, dress code, body language, telephone/online (skype) interviews, one-to-one interview & panel interview, FAQs related to job interviews

## Module 5

Formal writing: Technical Writing: differences between technical and literary style. Letter Writing (formal, informal and semi formal), Job applications, Minute preparation, CV preparation (differences between Bio-Data, CV and Resume), and Reports. Elements of style, Common Errors in Writing: describing a process, use of sequence words, Statements of Purpose, Instructions, Checklists.

Analytical and issue-based Essays and Report Writing: basics of report writing; Referencing Style (IEEE Format), structure of a report; types of reports, references, bibliography.

### Lab Activities

**Written:** Letter writing, CV writing, Attending a meeting and Minute Preparation, Vocabulary Building

**Spoken:** Phonetics, MMFS (Multimedia Feedback System), Mirroring, Elevator Pitch, telephone etiquette, qualities of a good presentation with emphasis on body language and use of visual aids.

**Listening:** Exercises based on audio materials like radio and podcasts. Listening to Song. practice and exercises.

**Reading:** Speed Reading, Reading with the help of Audio Visual Aids, Reading Comprehension Skills

**Mock interview and Debate/Group Discussion:** concepts, types, Do's and don'ts- intensive practice

### Reference Books

1. English for Engineers and Technologists (Combined edition, Vol. 1 and 2), Orient Blackswan 2010.
2. Meenakshi Raman and Sangeetha Sharma, "Technical Communication: Principles and Practice", 2nd Edition, Oxford University Press, 2011
3. Stephen E. Lucas, "The Art of Public Speaking", 10<sup>th</sup> Edition; McGraw Hill Education, 2012.
4. Ashraf Rizvi, "Effective Technical Communication", 2<sup>nd</sup> Edition, McGraw Hill Education, 2017.
5. William Strunk Jr. & E.B. White, "The Elements of Style", 4<sup>th</sup> Edition, Pearson, 1999.
6. David F. Beer and David McMurrey, Guide to writing as an Engineer, John Willey. New York, 2004.
7. Goodheart-Willcox, "Professional Communication", First Edition, 2017.
8. Training in Interpersonal Skills: Tips for Managing People at Work, Pearson Education, India, 6 edition, 2015.
9. The Ace of Soft Skills: Attitude, Communication and Etiquette for Success, Pearson Education; 1 edition, 2013.
10. Anand Ganguly, "Success in Interview", RPH, 5th Edition, 2016.
11. Raman Sharma, "Technical Communications", Oxford Publication, London, 2004.

COURSE CODE	COURSE NAME	CATEGORY	L	T	P	CREDITS
22EST209	PROGRAMMING IN C	MNC	2	1	2	4

**Preamble:** The syllabus is prepared with the view of preparing the Engineering Graduates capable of writing readable C programs to solve computational problems that they may have to solve in their professional life. The course content is decided to cover the essential programming fundamentals which can be taught within the given slots in the curriculum. This course has got 2 Hours per week for practicing programming in C. A list showing 24 mandatory programming problems are given at the end. The instructor is supposed to give homework/assignments to write the listed programs in the rough record as and when the required theory part is covered in the class. The students are expected to come prepared with the required program written in the rough record for the lab classes.

**Prerequisite:** NIL

**Course Outcomes:** After the completion of the course the student will be able to

<b>CO 1</b>	Analyze a computational problem and develop an algorithm/flowchart to find its solution
<b>CO 2</b>	Develop readable* C programs with branching and looping statements, which uses Arithmetic, Logical, Relational or Bitwise operators.
<b>CO 3</b>	Write readable C programs with arrays, structure or union for storing the data to be processed
<b>CO 4</b>	Divide a given computational problem into a number of modules and develop a readable multi-function C program by using recursion if required, to find the solution to the computational problem
<b>CO 5</b>	Write readable C programs which use pointers for array processing and parameter passing
<b>CO 6</b>	Develop readable C programs with files for reading input and storing output
<p>readable* - readability of a program means the following:</p> <ol style="list-style-type: none"> <li>1. Logic used is easy to follow</li> <li>2. Standards to be followed for indentation and formatting</li> <li>3. Meaningful names are given to variables</li> <li>4. Concise comments are provided wherever needed</li> </ol>	

### Mapping of course outcomes with program outcomes

	PO1	PO2	PO3	PO4	PO5	PO6	PO7	PO8	PO9	PO10	PO11	PO12
CO1	☑	☑	☑	☑		☑				☑	☑	☑
CO2	☑	☑	☑	☑	☑					☑		☑
CO3	☑	☑	☑	☑	☑					☑		☑
CO4	☑	☑	☑	☑	☑					☑	☑	☑
CO5	☑	☑			☑					☑		☑
CO6	☑	☑			☑					☑		☑

### Assessment Pattern

Bloom's Category	Continuous Assessment Tests		End Semester Examination Marks
	Test 1 (Marks)	Test 2 (Marks)	
Remember	15	10	25
Understand	10	15	25
Apply	20	20	40
Analyse	5	5	10
Evaluate			
Create			

### Mark distribution

Total Marks	CIE Marks	ESE Marks	ESE Duration
150	50	100	3 hours

**Continuous Internal Evaluation Pattern:**

Attendance	: 10 marks
Continuous Assessment Test 1 (for theory, for 2 hrs)	: 20 marks
Continuous Assessment Test 2 (for lab, internal examination, for 2 hrs)	: 20 marks

**Internal Examination Pattern:** There will be two parts; Part A and Part B. Part A contains 5 questions with 2 questions from each module (2.5 modules x 2 = 5), having 3 marks for each question. Students should answer all questions. Part B also contains 5 questions with 2 questions from each module (2.5 modules x 2 = 5), of which a student should answer any one. The questions should not have sub-divisions and each one carries 7 marks.

**End Semester Examination Pattern:** There will be two parts; Part A and Part B. Part A contains 10 questions with 2 questions from each module, having 3 marks for each question. Students should answer all questions. Part B contains 2 questions from each module of which a student should answer any one. Each question can have maximum 2 sub-divisions and carry 14 marks.

**Sample Course Level Assessment Questions**

**Course Outcome 1 (CO1):** Write an algorithm to check whether largest of 3 natural numbers is prime or not. Also, draw a flowchart for solving the same problem.

**Course Outcome 2 (CO2):** Write an easy to read C program to process a set of n natural numbers and to find the largest even number and smallest odd number from the given set of numbers. The program should not use division and modulus operators.

**Course Outcome 3(CO3):** Write an easy to read C program to process the marks obtained by n students of a class and prepare their rank list based on the sum of the marks obtained. There are 3 subjects for which examinations are conducted and the third subject is an elective where a student is allowed to take any one of the two courses offered.

**Course Outcome 4 (CO4):** Write an easy to read C program to find the value of a mathematical function f which is defined as follows.  $f(n) = n! / (\text{sum of factors of } n)$ , if n is not prime and  $f(n) = n! / (\text{sum of digits of } n)$ , if n is prime.

**Course Outcome 5 (CO5):** Write an easy to read C program to sort a set of n integers and to find the number of unique numbers and the number of repeated numbers in the given set of numbers. Use a function which takes an integer array of n elements, sorts the array using the Bubble Sorting Technique and returns the number of unique numbers and the number of repeated numbers in the given array.

**Course Outcome 6 (CO6):** Write an easy to read C program to process a text file and to print the Palindrome words into an output file.

**Model Question paper**

**QP CODE:**

**PAGES:3**

Reg No: \_\_\_\_\_

Name : \_\_\_\_\_

**APJ ABDUL KALAM TECHNOLOGICAL UNIVERSITY FIRST SEMESTER B.TECH DEGREE EXAMINATION,  
MONTH & YEAR**

**Course Code: EST 102**

**Course Name: Programming in C (Common to all programs)**

**Max.Marks:100**

**Duration: 3 Hours**

**PART A**

**Answer all Questions. Each question carries 3 Marks**

1. Write short note on processor and memory in a computer.
2. What are the differences between compiled and interpreted languages? Give example for each.
3. Write a C program to read a Natural Number through keyboard and to display the reverse of the given number. For example, if "3214567" is given as input, the output to be shown is "7654123".
4. Is it advisable to use *goto* statements in a C program? Justify your answer.
5. Explain the different ways in which you can *declare & initialize* a single dimensional array.
6. Write a C program to read a sentence through keyboard and to display the count of white spaces in the given sentence.
7. What are the advantages of using functions in a program?
8. With a simple example program, explain *scope* and *life time* of variables in C.
9. Write a function in C which takes the address of a single dimensional array (containing a finite sequence of numbers) and the number of numbers stored in the array as arguments and stores the numbers in the same array in reverse order. Use pointers to access the elements of the array.
10. With an example, explain the different modes of opening a file. (10x3=30)

**Part B**

**Answer any one Question from each module. Each question carries 14 Marks**

11. (a) Draw a flow chart to find the position of an element in a given sequence, using linear searching technique. With an example explain how the flowchart finds the position of a given element. (10)  
(b) Write a pseudo code representing the flowchart for linear searching. (4)

**OR**



12. (a) With the help of a flow chart, explain the bubble sort operation. Illustrate with an example. **(10)**  
(b) Write an algorithm representing the flowchart for bubble sort. **(4)**

13. (a) Write a C program to read an English Alphabet through keyboard and display whether the given Alphabet is in upper case or lower case. **(6)**  
(b) Explain how one can use the builtin function in C, *scanf* to read values of different data types. Also explain using examples how one can use the builtin function in C, *printf* for text formatting. **(8)**

**OR**

14. (a) With suitable examples, explain various operators in C. **(10)**  
(b) Explain how characters are stored and processed in C. **(4)**

15. (a) Write a function in C which takes a 2-Dimensional array storing a matrix of numbers and the order of the matrix (number of rows and columns) as arguments and displays the sum of the elements stored in each row. **(6)**  
(b) Write a C program to check whether a given matrix is a diagonal matrix. **(8)**

**OR**

16. (a) Without using any builtin string processing function like *strlen*, *strcat* etc., write a program to concatenate two strings. **(8)**  
(b) Write a C program to perform bubble sort. **(6)**

17. (a) Write a function namely *myFact* in C to find the factorial of a given number. Also, write another function in C namely *nCr* which accepts two positive integer parameters *n* and *r* and returns the value of the mathematical function  $C(n,r) = \frac{n!}{r! \times (n-r)!}$ . The function *nCr* is expected to make use of the factorial function *myFact*. **(10)**  
(b) What is recursion? Give an example. **(4)**

**OR**

18. (a) With a suitable example, explain the differences between a structure and a union in C. **(6)**  
(b) Declare a structure namely *Student* to store the details (*roll number*, *name*, *mark\_for\_C*) of a student. Then, write a program in C to find the average mark obtained by the students in a class for the subject *Programming in C* (using the field *mark\_for\_C*). Use array of structures to store the required data **(8)**

19. (a) With a suitable example, explain the concept of pass by reference. **(6)**  
(b) With a suitable example, explain how pointers can help in changing the content of a single dimensionally array passed as an argument to a function in C. **(8)**

**OR**

20. (a) Differentiate between sequential files and random access files? **(4)**

(b) Using the prototypes explain the functionality provided by the following functions. (10)

*rewind()*

i. *fseek()*

ii. *ftell()*

iii. *fread()*

iv. *fwrite()*

**(14X5=70)**

## **SYLLABUS**

### **Programming in C (Common to all disciplines)**

#### **Module 1**

##### **Basics of Computer Hardware and Software**

Basics of Computer Architecture: processor, Memory, Input & Output devices

Application Software & System software: Compilers, interpreters, High level and low level languages

Introduction to structured approach to programming, Flow chart Algorithms, Pseudo code (*bubble sort, linear search - algorithms and pseudocode*)

#### **Module 2**

##### **Program Basics**

Basic structure of C program: Character set, Tokens, Identifiers in C, Variables and Data Types, Constants, Console IO Operations, printf and scanf

Operators and Expressions: Expressions and Arithmetic Operators, Relational and Logical Operators, Conditional operator, size of operator, Assignment operators and Bitwise Operators. Operators Precedence

Control Flow Statements: If Statement, Switch Statement, Unconditional Branching using goto statement, While Loop, Do While Loop, For Loop, Break and Continue statements. (Simple programs covering control flow)

#### **Module 3**

##### **Arrays and strings**

Arrays Declaration and Initialization, 1-Dimensional Array, 2-Dimensional Array

String processing: In built String handling functions (strlen, strcpy, strcat and strcmp, puts, gets)

Linear search program, bubble sort program, simple programs covering arrays and strings

#### **Module 4**

##### **Working with functions**

Introduction to modular programming, writing functions, formal parameters, actual parameters

Pass by Value, Recursion, Arrays as Function Parameters structure, union, Storage Classes, Scope and life time of variables, *simple programs using functions*

## Module 5

### Pointers and Files

Basics of Pointer: declaring pointers, accessing data through pointers, NULL pointer, array access using pointers, pass by reference effect

File Operations: open, close, read, write, append

Sequential access and random access to files: In built file handling functions (*rewind()*, *fseek()*, *ftell()*, *feof()*, *fread()*, *fwrite()*), simple programs covering pointers and files.

### Text Books

1. Schaum Series, Gottfried B.S., Tata McGraw Hill, Programming with C
2. E. Balagurusamy, McGraw Hill, Programming in ANSI C
3. Asok N Kamthane, Pearson, Programming in C
4. Anita Goel, Pearson, Computer Fundamentals

### Reference Books

1. Anita Goel and Ajay Mittal, Pearson, Computer fundamentals and Programming in C
2. Brian W. Kernighan and Dennis M. Ritchie, Pearson, C Programming Language
3. Rajaraman V, PHI, Computer Basics and Programming in C
4. Yashavant P, Kanetkar, BPB Publications, Let us C

## Course Contents and Lecture Schedule

Module 1: Basics of Computer Hardware and Software		(7 hours)
1.1	<b>Basics of Computer Architecture:</b> Processor, Memory, Input & Output devices	2 hours
1.2	<b>Application Software &amp; System software:</b> Compilers, interpreters, High level and low level languages	2 hours
1.3	Introduction to structured approach to programming, Flow chart	1 hours
1.4	Algorithms, Pseudo code ( <i>bubble sort, linear search - algorithms and pseudocode</i> )	2 hours
Module 2: Program Basics		(8 hours)
2.1	<b>Basic structure of C program:</b> Character set, Tokens, Identifiers in C, Variables and Data Types, Constants, Console IO Operations, printf and scanf	2 hours
2.2	<b>Operators and Expressions:</b> Expressions and Arithmetic Operators, Relational and Logical Operators, Conditional operator, sizeof operator, Assignment operators and Bitwise Operators. Operators Precedence	2 hours

2.3	<b>Control Flow Statements:</b> If Statement, Switch Statement, Unconditional Branching using goto statement, While Loop, Do While Loop, For Loop, Break and Continue statements. <i>(Simple programs covering control flow)</i>	4 hours
<b>Module 3: Arrays and strings:</b>		<b>(6 hours)</b>
3.1	Arrays Declaration and Initialization, 1-Dimensional Array, 2-Dimensional Array	2 hours
3.2	<b>String processing:</b> In built String handling functions( <i>strlen, strcpy, strcat and strcmp, puts, gets</i> )	2 hours
3.3	Linear search program, bubble sort program, <i>simple programs covering arrays and strings</i>	3 hours
<b>Module 4: Working with functions</b>		<b>(7 hours)</b>
4.1	Introduction to modular programming, writing functions, formal parameters, actual parameters	2 hours
4.2	Pass by Value, Recursion, Arrays as Function Parameters	2 hours
4.3	structure, union, Storage Classes, Scope and life time of variables, <i>simple programs using functions</i>	3 hours
<b>Module 5: Pointers and Files</b>		<b>(7 hours)</b>
5.1	<b>Basics of Pointer:</b> declaring pointers, accessing data through pointers, NULL pointer, array access using pointers, pass by reference effect	3 hours
5.2	<b>File Operations:</b> open, close, read, write, append	1 hours
5.3	<b>Sequential access and random access to files:</b> In built file handling functions ( <i>rewind(), fseek(), ftell(), feof(), fread(), fwrite()</i> ), <i>simple programs covering pointers and files.</i>	2 hours

#### C PROGRAMMING LAB (Practical part of EST 102, Programming in C)

**Assessment Method:** The Academic Assessment for the Programming lab should be done internally by the College. The assessment shall be made on 50 marks and the mark is divided as follows: Practical Records/Outputs - 20 marks (internal by the College), Regular Lab Viva - 5 marks (internal by the College), Final Practical Exam – 25 marks (internal by the College).

**The mark obtained out of 50 will be converted into equivalent proportion out of 20 for CIE computation.**

### LIST OF LAB EXPERIMENTS

1. Familiarization of Hardware Components of a Computer
2. Familiarization of Linux environment – How to do Programming in C with Linux
3. Familiarization of console I/O and operators in C
  - i) Display “Hello World”
  - ii) Read two numbers, add them and display their sum
  - iii) Read the radius of a circle, calculate its area and display it
  - iv) Evaluate the arithmetic expression  $((a - b / c * d + e) * (f + g))$  and display its solution. Read the values of the variables from the user through console.
4. Read 3 integer values and find the largest among them.
5. Read a Natural Number and check whether the number is prime or not
6. Read a Natural Number and check whether the number is Armstrong or not
7. Read n integers, store them in an array and find their sum and average
8. Read n integers, store them in an array and search for an element in the array using an algorithm for Linear Search
9. Read n integers, store them in an array and sort the elements in the array using Bubble Sort algorithm
10. Read a string (word), store it in an array and check whether it is a palindrome word or not.
11. Read two strings (each one ending with a \$ symbol), store them in arrays and concatenate them without using library functions.
12. Read a string (ending with a \$ symbol), store it in an array and count the number of vowels, consonants and spaces in it.
13. Read two input each representing the distances between two points in the Euclidean space, store these in structure variables and add the two distance values.
14. Using structure, read and print data of n employees (*Name, Employee Id and Salary*)
15. Declare a union containing 5 string variables (*Name, House Name, City Name, State and Pin code*) each with a length of C\_SIZE (user defined constant). Then, read and display the address of a person using a variable of the union.
16. Find the factorial of a given Natural Number n using recursive and non recursive functions
17. Read a string (word), store it in an array and obtain its reverse by using a user defined function.
18. Write a menu driven program for performing matrix addition, multiplication and finding the transpose. Use functions to (i) read a matrix, (ii) find the sum of two matrices, (iii) find the product of two matrices, (iv) find the transpose of a matrix and (v) display a matrix.
19. Do the following using pointers
  - i) add two numbers
  - ii) swap two numbers using a user defined function
20. Input and Print the elements of an array using pointers
21. Compute sum of the elements stored in an array using pointers and user defined function.
22. Create a file and perform the following
  - iii) Write data to the file
  - iv) Read the data in a given file & display the file content on console
  - v) append new data and display on console
23. Open a text input file and count number of characters, words and lines in it; and store the results in an output file.

COURSE CODE	COURSE NAME	CATEGORY	L	T	P	CREDITS
22PHL210	ENGINEERING PHYSICS LAB	ES	0	0	2	1

**Preamble:** The aim of this course is to make the students gain practical knowledge to co-relate with the theoretical studies and to develop practical applications of engineering materials and use the principle in the right way to implement the modern technology.

**Prerequisite:** Higher secondary level Physics

**Course Outcomes:** After the completion of the course the student will be able to

<b>CO 1</b>	Develop analytical/experimental skills and impart prerequisite hands on experience for engineering laboratories
<b>CO 2</b>	Understand the need for precise measurement practices for data recording
<b>CO 3</b>	Understand the principle, concept, working and applications of relevant technologies and comparison of results with theoretical calculations
<b>CO 4</b>	Analyze the techniques and skills associated with modern scientific tools such as lasers and fiber optics
<b>CO 5</b>	Develop basic communication skills through working in groups in performing the laboratory experiments and by interpreting the results

#### Mapping of course outcomes with program outcomes

	PO 1	PO 2	PO 3	PO 4	PO 5	PO 6	PO 7	PO 8	PO 9	PO 10	PO 11	PO 12
<b>CO 1</b>	3				3			1	2			1
<b>CO 2</b>	3				3			1	2			1
<b>CO 3</b>	3				3			1	2			1
<b>CO 4</b>	3				3			1	2			1
<b>CO 5</b>	3				3			1	2			1

#### Mark distribution

Total Marks	CIE Marks	ESE Marks	ESE Duration(Internal)
100	100	-	1 hour

**Continuous Internal Evaluation Pattern:**

Attendance	: 20 marks
Class work/ Assessment /Viva-voce	: 50 marks
End semester examination (Internally by college)	: 30 marks

**End Semester Examination Pattern:** Written Objective Examination of one hour

**SYLLABUS****LIST OF EXPERIMENTS**

**(Minimum 8 experiments should be completed)**

1. CRO-Measurement of frequency and amplitude of wave forms
2. Measurement of strain using strain gauge and wheatstone bridge
3. LCR Circuit – Forced and damped harmonic oscillations
4. Melde’s string apparatus- Measurement of frequency in the transverse and longitudinal mode
5. Wave length measurement of a monochromatic source of light using Newton’s Rings method.
6. Determination of diameter of a thin wire or thickness of a thin strip of paper using air wedge method.
7. To measure the wavelength using a millimeter scale as a grating.
8. Measurement of wavelength of a source of light using grating.
9. Determination of dispersive power and resolving power of a plane transmission grating
10. Determination of the particle size of lycopodium powder
11. Determination of the wavelength of He-Ne laser or any standard laser using diffraction grating
12. Calculate the numerical aperture and study the losses that occur in optical fiber cable.
13. I-V characteristics of solar cell.
14. LED Characteristics.
15. Ultrasonic Diffractometer- Wavelength and velocity measurement of ultrasonic waves in a liquid
16. Deflection magnetometer-Moment of a magnet- Tan A position.

**Reference books**

1. S.L.Gupta and Dr.V.Kumar, “Practical physics with viva voice”, Pragati Prakashan Publishers, Revised Edition, 2009
2. M.N.Avadhanulu, A.A.Dani and Pokely P.M, “Experiments in Engineering Physics”, S.Chand&Co,2008
3. S. K. Gupta, “Engineering physics practicals”, Krishna Prakashan Pvt. Ltd., 2014
4. P. R. Sasikumar “Practical Physics”, PHI Ltd., 2011.

COURSE CODE	COURSE NAME	CATEGORY	L	T	P	CREDITS
22CYL211	ENGINEERING CHEMISTRY LAB	ES	0	0	2	1

**Preamble:** To impart scientific approach and to familiarize with the experiments in chemistry relevant for research projects in higher semesters

**Prerequisite:** Experiments in chemistry introduced at the plus two levels in schools

**Course outcomes:** After the completion of the course the students will be able to

<b>CO 1</b>	Understand and practice different techniques of quantitative chemical analysis to generate experimental skills and apply these skills to various analyses
<b>CO 2</b>	Develop skills relevant to synthesize organic polymers and acquire the practical skill to use TLC for the identification of drugs
<b>CO 3</b>	Develop the ability to understand and explain the use of modern spectroscopic techniques for analysing and interpreting the IR spectra and NMR spectra of some organic compounds
<b>CO 4</b>	Acquire the ability to understand, explain and use instrumental techniques for chemical analysis
<b>CO 5</b>	Learn to design and carry out scientific experiments as well as accurately record and analyze the results of such experiments
<b>CO 6</b>	Function as a member of a team, communicate effectively and engage in further learning. Also understand how chemistry addresses social, economical and environmental problems and why it is an integral part of curriculum

#### Mapping of course outcomes with program outcomes

	PO 1	PO 2	PO 3	PO 4	PO 5	PO 6	PO 7	PO 8	PO 9	PO 10	PO 11	PO 12
<b>CO 1</b>	3				2							3
<b>CO 2</b>	3				3							3
<b>CO 3</b>	3				3							3
<b>CO 4</b>	3				3							3
<b>CO 5</b>	3				1							3
<b>CO 6</b>	3				1							3

#### Mark distribution

Total Marks	CIE marks	ESE marks	ESE Duration(Internal)
100	100	-	1 hour



**Continuous Internal Evaluation Pattern:**

Attendance : 20 marks

Class work/ Assessment /Viva-voce : 50 marks

End semester examination (Internally by college) : 30 marks

**End Semester Examination Pattern:** Written Objective Examination of one hour

**SYLLABUS****LIST OF EXPERIMENTS (MINIMUM 8 MANDATORY)**

1. Estimation of total hardness of water-EDTA method
2. Potentiometric titration
3. Determination of cell constant and conductance of solutions.
4. Calibration of pH meter and determination of pH of a solution
5. Estimation of chloride in water
6. Identification of drugs using TLC
7. Determination of wavelength of absorption maximum and colorimetric estimation of  $\text{Fe}^{3+}$  in solution
8. Determination of molar absorptivity of a compound ( $\text{KMnO}_4$  or any water soluble food colorant)
9. Synthesis of polymers (a) Urea-formaldehyde resin (b) Phenol-formaldehyde resin
10. Estimation of iron in iron ore
11. Estimation of copper in brass
12. Estimation of dissolved oxygen by Winkler's method
13. (a) Analysis of IR spectra (minimum 3 spectra) (b) Analysis of  $^1\text{H}$  NMR spectra (minimum 3 spectra)
14. Flame photometric estimation of  $\text{Na}^+$  to find out the salinity in sand
15. Determination of acid value of a vegetable oil
16. Determination of saponification of a vegetable oil

**Reference Books**

1. G. Svehla, B. Sivasankar, "Vogel's Qualitative Inorganic Analysis", Pearson, 2012.
2. R. K. Mohapatra, "Engineering Chemistry with Laboratory Experiments", PHI Learning, 2017.
3. Muhammed Arif, "Engineering Chemistry Lab Manual", Owl publishers, 2019.
4. Ahad J., "Engineering Chemistry Lab manual", Jai Publications, 2019.
5. Roy K Varghese, "Engineering Chemistry Laboratory Manual", Crownplus Publishers, 2019.
6. Soney C George, Rino Laly Jose, "Lab Manual of Engineering Chemistry", S. Chand & Company Pvt Ltd, New Delhi, 2019.



CO 7	2											
CO 8	2											

### Mark distribution

Total Marks	CIE	ESE	ESE Duration
100	70	30	1 hour

**Assessment Procedure:** Total marks allotted for the course is 100 marks. CIE shall be conducted for 70 marks and ESE for 30 marks. CIE should be done for the work done by the student and also viva voce based on the work done on each practical session. ESE shall be evaluated by written examination of one hour duration conducted internally by the institute.

### Continuous Internal Evaluation Pattern:

Attendance	: 20 marks
Class work/ Assessment /Viva-voce	: 50 marks
End semester examination (Internally by college)	: 30 marks

**End Semester Examination Pattern:** Written Objective Examination of one hour

## SYLLABUS

### PART 1

#### CIVIL WORKSHOP

- Exercise 1. Calculate the area of a built-up space and a small parcel of land- Use standard measuring tape and digital distance measuring devices
- Exercise 2. (a) Use screw gauge and vernier calliper to measure the diameter of a steel rod and thickness of a flat bar
- (b) Transfer the level from one point to another using a water level
- (c) Set out a one room building with a given plan and measuring tape
- Exercise 3. Find the level difference between any two points using dumpy level
- Exercise 4. (a) Construct a  $1\frac{1}{2}$  thick brick wall of 50 cm height and 60 cm length using English bond. Use spirit level to assess the tilt of walls.
- (b) Estimate the number of different types of building blocks to construct this wall.

Exercise 5. (a) Introduce the students to plumbing tools, different types of pipes, type of connections, traps, valves, fixtures and sanitary fittings.

(b) Install a small rainwater harvesting installation in the campus

**Reference Books:**

1. Khanna P.N, "Indian Practical Civil Engineering Handbook", Engineers Publishers.
2. Bhavikatti. S, "Surveying and Levelling (Volume 1)", I.K. International Publishing House
3. Arora S.P and Bindra S.P, " Building Construction", Dhanpat Rai Publications
4. S. C. Rangwala, "Engineering Materials," Charotar Publishing House.

**PART II**

**MECHANICAL WORKSHOP**

**LIST OF EXERCISES**

(Minimum EIGHT units mandatory and FIVE models from Units 2 to 8 mandatory)

UNIT 1:- General : Introduction to workshop practice, Safety precautions, Shop floor ethics, Basic First Aid knowledge.

Study of mechanical tools, components and their applications: (a) Tools: screw drivers, spanners, Allen keys, cutting pliers etc and accessories (b) bearings, seals, O-rings, circlips, keys etc.

UNIT 2:- Carpentry : Understanding of carpentry tools

Minimum any one model

1. T-Lap joint
2. Cross lap joint
3. Dovetail joint
4. Mortise joints

UNIT 3:- Foundry : Understanding of foundry tools

Minimum any one model

1. Bench Molding
2. Floor Molding
3. Core making
4. Pattern making

UNIT 4: - Sheet Metal : Understanding of sheet metal working tools

Minimum any one model

1. Cylindrical shape
2. Conical shape
3. Prismatic shaped job from sheet metal

UNIT 5: - Fitting : Understanding of tools used for fitting

Minimum any one model

1. Square Joint
2. V- Joint
3. Male and female fitting

UNIT 6: - Plumbing : Understanding of plumbing tools, pipe joints

Any one exercise on joining of pipes making use of minimum three types of pipe joints

UNIT 7: - Smithy: Understanding of tools used for smithy.

Demonstrating the forge-ability of different materials (MS, Al, alloy steel and cast steels) in cold and hot states.

Observing the qualitative difference in the hardness of these materials

Minimum any one exercise on smithy

1. Square prism
2. Hexagonal headed bolt
3. Hexagonal prism
4. Octagonal prism

UNIT 8: -Welding: Understanding of welding equipments

Minimum any one welding practice

Making Joints using electric arc welding. bead formation in horizontal, vertical and over head positions

UNIT 9: - Assembly: Demonstration only

Disassembling and assembling of

1. Cylinder and piston assembly
2. Tail stock assembly
3. Bicycle
4. Pump or any other machine

UNIT 10: - Machines: Demonstration and applications of the following machines

Shaping and slotting machine; Milling machine; Grinding Machine; Lathe; Drilling Machine.

UNIT 11: - Modern manufacturing methods: Power tools, CNC machine tools, 3D printing, Glass cutting.

**Course Contents and Lecture Schedule:**

No	Topic	No of Sessions
1	<b>INTRODUCTION</b>	
1.1	Workshop practice, shop floor precautions, ethics and First Aid knowledge. Studies of mechanical tools, components and their applications: (a) Tools: screw drivers, spanners, Allen keys, cutting pliers etc and accessories (b) bearings, seals, O-rings, circlips, keys etc	1
2	<b>CARPENTRY</b>	
2.1	Understanding of carpentry tools and making minimum one model	2

3	<b>FOUNDRY</b>	
3.1	Understanding of foundry tools and making minimum one model	2
4	<b>SHEET METAL</b>	
4.1	Understanding of sheet metal working tools and making minimum one model	2
5	<b>FITTING</b>	
5.1	Understanding of fitting tools and making minimum one model	2
6	<b>PLUMBING</b>	
6.1	Understanding of pipe joints and plumbing tools and making minimum one model	2
7	<b>SMITHY</b>	
7.1	Understanding of smithy tools and making minimum one model	2
8	<b>WELDING</b>	
8.1	Understanding of welding equipments and making minimum one model	2
9	<b>ASSEMBLY</b>	
9.1	Demonstration of assembly and disassembling of multiple parts components	1
10	<b>MACHINES</b>	
10.1	Demonstration of various machines	1
11	<b>MODERN MANUFACTURING METHODS</b>	
11.1	Demonstrations of: power tools, CNC Machine tools, 3D printing, Glass cutting	1

COURSE CODE	COURSE NAME	CATEGORY	L	T	P	CREDITS
22ESL213	ELECTRICAL & ELECTRONICS WORKSHOP	ES	0	0	2	1

**Preamble:** Electrical Workshop is intended to impart skills to plan and carry out simple electrical wiring. It is essential for the practicing engineers to identify the basic practices and safety measures in electrical wiring.

**Prerequisite:** NIL

**Course Outcomes:** After the completion of the course the student will be able to

<b>CO 1</b>	Demonstrate safety measures against electric shocks.
<b>CO 2</b>	Identify the tools used for electrical wiring, electrical accessories, wires, cables, batteries and standard symbols
<b>CO 3</b>	Develop the connection diagram, identify the suitable accessories and materials necessary for wiring simple lighting circuits for domestic buildings
<b>CO 4</b>	Identify and test various electronic components
<b>CO 5</b>	Draw circuit schematics with EDA tools
<b>CO 6</b>	Assemble and test electronic circuits on boards
<b>CO 7</b>	Work in a team with good interpersonal skills

#### Mapping of course outcomes with program outcomes

	PO 1	PO 2	PO 3	PO 4	PO 5	PO 6	PO 7	PO 8	PO 9	PO 10	PO 11	PO 12
<b>CO 1</b>	-	-	-	-	-	3	-	-	-	-	-	1
<b>CO 2</b>	2	-	-	-	-	-	-	-	-	1	-	-
<b>CO 3</b>	2	-	-	1	-	1	-	1	2	2	-	2
<b>CO 4</b>	3	-	-	-	-	-	-	-	-	-	-	2
<b>CO 5</b>	3	-	-	-	2	-	-	-	-	-	-	2
<b>CO 6</b>	3	-	-	-	2	-	-	-	-	-	-	1
<b>CO 7</b>	-	-	-	-	-	-	-	-	3	2	-	2

#### Mark distribution

Total Marks	CIE	ESE	ESE Duration(Internal)
100	100	-	1 hour

**Continuous Internal Evaluation Pattern:**

Attendance	: 20 marks
Class work/ Assessment /Viva-voce	: 50 marks
End semester examination (Internally by college)	: 30 marks

**End Semester Examination Pattern:** Written Objective Examination of one hour

**Syllabus**

**PART 1**

**ELECTRICAL**

**List of Exercises / Experiments**

1. a) Demonstrate the precautionary steps adopted in case of Electrical shocks.  
b) Identify different types of cables, wires, switches, fuses, fuse carriers, MCB, ELCB and MCCB with ratings.
2. Wiring of simple light circuit for controlling light/ fan point (PVC conduit wiring)
3. Wiring of light/fan circuit using Two way switches . (Staircase wiring)
4. Wiring of Fluorescent lamps and light sockets (6A) with a power circuit for controlling power device. (16A socket)
5. Wiring of power distribution arrangement using single phase MCB distribution board with ELCB, main switch and Energy meter.
6. a) Identify different types of batteries with their specifications.  
b) Demonstrate the Pipe and Plate Earthing Schemes using Charts/Site Visit.

**PART II**

**ELECTRONICS**

**List of Exercises / Experiments (Minimum of 7 mandatory)**

1. Familiarization/Identification of electronic components with specification (Functionality, type, size, colour coding, package, symbol, cost etc. [Active, Passive, Electrical, Electronic, Electro-mechanical, Wires, Cables, Connectors, Fuses, Switches, Relays, Crystals, Displays, Fasteners, Heat sink etc.]



2. Drawing of electronic circuit diagrams using BIS/IEEE symbols and introduction to EDA tools (such as Dia or Xcircuit), Interpret data sheets of discrete components and IC's, Estimation and costing.
3. Familiarization/Application of testing instruments and commonly used tools. [Multimeter, Function generator, Power supply, DSO etc.] [Soldering iron, De-soldering pump, Pliers, Cutters, Wire strippers, Screw drivers, Tweezers, Crimping tool, Hot air soldering and de- soldering station etc.]
4. Testing of electronic components [Resistor, Capacitor, Diode, Transistor and JFET using multimeter.]
5. Inter-connection methods and soldering practice. [Bread board, Wrapping, Crimping, Soldering - types - selection of materials and safety precautions, soldering practice in connectors and general purpose PCB, Crimping.]
6. Printed circuit boards (PCB) [Types, Single sided, Double sided, PTH, Processing methods, Design and fabrication of a single sided PCB for a simple circuit with manual etching (Ferric chloride) and drilling.]
7. Assembling of electronic circuits using SMT (Surface Mount Technology) stations.
8. Assembling of electronic circuit/system on general purpose PCB, test and show the functioning (**Any Two circuits**).
  1. Fixed voltage power supply with transformer, rectifier diode, capacitor filter, zener/IC regulator.
  2. Square wave generation using IC 555 timer in IC base.
  3. Sine wave generation using IC 741 OP-AMP in IC base.
  4. RC coupled amplifier with transistor BC107.

# **SEMESTER - 3**

COURSE CODE	COURSE NAME	CATEGORY	L	T	P	CREDITS
22MAT301	PARTIAL DIFFERENTIAL EQUATION AND COMPLEX ANALYSIS	BS	3	1	0	4

**Preamble:** This course introduces basic ideas of partial differential equations which are widely used in the modelling and analysis of a wide range of physical phenomena and has got application across all branches of engineering. To understand the basic theory of functions of a complex variable, residue integration and conformal transformation.

**Prerequisite:** A basic course in partial differentiation and complex numbers.

**Course Outcomes:** After the completion of the course the student will be able to

<b>CO 1</b>	Understand the concept and the solution of partial differential equation.
<b>CO 2</b>	Analyse and solve one dimensional wave equation and heat equation.
<b>CO 3</b>	Understand complex functions, its continuity differentiability with the use of Cauchy-Riemann equations.
<b>CO 4</b>	Evaluate complex integrals using Cauchy's integral theorem and Cauchy's integral formula, understand the series expansion of analytic function
<b>CO 5</b>	Understand the series expansion of complex function about a singularity and Apply residue theorem to compute several kinds of real integrals.

#### Mapping of course outcomes with program outcomes

PO's	Broad area
PO 1	Engineering Knowledge
PO 2	Problem Analysis
PO 3	Design/Development of solutions
PO 4	Conduct investigations of complex problems
PO 5	Modern tool usage
PO 6	The Engineer and Society
PO 7	Environment and Sustainability
PO 8	Ethics
PO 9	Individual and team work

PO 10	Communication
PO 11	Project Management and Finance
PO 12	Life long learning

### Mapping of course outcomes with program outcomes

	PO 1	PO 2	PO 3	PO 4	PO 5	PO 6	PO 7	PO 8	PO 9	PO 10	PO 11	PO 12
CO 1	3	3	3	3	2	1				2		2
CO 2	3	3	3	3	2	1				2		2
CO 3	3	3	3	3	2	1				2		2
CO 4	3	3	3	3	2	1				2		2
CO 5	3	3	3	3	2	1				2		2

### Assessment Pattern

Bloom's Category	Continuous Assessment Tests(%)		End Semester Examination(%)
	1	2	
Remember	10	10	10
Understand	30	30	30
Apply	30	30	30
Analyse	20	20	20
Evaluate	10	10	10
Create			

**End Semester Examination Pattern:** There will be two parts; Part A and Part B. Part A contain 10 questions with 2 questions from each module, having 3 marks for each question. Students should answer all questions. Part B contains 2 questions from each module of which student should answer any one. Each question can have maximum 2 sub-divisions and carry 14 marks.

### Course Level Assessment Questions.

#### Course Outcome 1 (CO1):

1. Form the partial differential equation given  $z = xf(x) + ye^2$
2. What is the difference between complete integral and singular integral of a partial differential equation
3. Solve  $3z = xp + yq$
4. Solve  $(p^2 + q^2)y = qz$
5. Solve  $u_x - 2u_t = u$  by the method of separation of variables

**Course Outcome 2 (CO2):**

1. Write any three assumptions in deriving one dimensional wave equations
2. Derive one Dimensional heat equation
3. Obtain a general solution for the one dimensional heat equation  $\frac{\partial u}{\partial t} = c^2 \frac{\partial^2 u}{\partial x^2}$
4. A tightly stretched flexible string has its ends fixed at  $x = 0$  and  $x = l$ . At  $t = 0$ , the string is given a shape defined by  $f(x) = \mu x(l - x)$  where  $\mu$  is a constant
5. Find the temperature  $u(x, t)$  in a bar which is perfectly insulated laterally whose ends are kept at  $0^\circ\text{C}$  and whose initial temperature (in degree Celsius) is  $f(x) = x(10 - x)$  given that its length is 10 cm and specific heat is 0.056 cal/gram deg

**Course Outcome 3 (CO3):**

1. Separate the real and imaginary parts of  $f(z) = \frac{1}{1+z}$
2. Check whether the function  $f(z) = \frac{\text{Re}(z^2)}{|z|}$  is continuous at  $z = 0$  given  $f(0) = 0$
3. Determine a and b so that function  $u = e^{-\pi x} \cos ay$  is harmonic. Find its harmonic conjugate.
4. Find the fixed points of  $w = \frac{i}{2z-1}$
5. Find the image of  $|z| \leq \frac{1}{2}$ ,  $-\frac{\pi}{8} < \arg z < \frac{\pi}{8}$  under  $w = z^2$

**Course Outcome 4 (CO4):**

1. Find the value of  $\int_C \exp(z^2) dz$  where C is  $|z| = 1$
2. Integrate the function  $\int_C \frac{\sin z}{z+4iz} dz$  where C is  $|z - 4 - 2i| = 6.5$
3. Evaluate  $\int_C \frac{e^z}{(z-\frac{\pi}{4})^3} dz$  where C is  $|z| = 1$
4. Find the Maclaurin series expansion of  $f(z) = \frac{i}{1-z}$  and state the region of convergence.
5. Find the image of  $|z| = 2$  under the mapping  $w = z + \frac{1}{z}$

**Course Outcome 5 (CO5):**

1. Determine the singularity of  $\exp\left(\frac{1}{z}\right)$
2. Find the Laurent series of  $\frac{1}{z^2(z-i)}$  about  $z = i$
3. Find the residues of  $f(z) = \frac{50z}{z^3 + 2z^2 - 7z + 4}$
4. Evaluate  $\int_C \tan 2\pi z dz$  where C is  $|z - 0.2| = 0.2$
5. Evaluate  $\int_0^{2\pi} \frac{d\theta}{\sqrt{2} - \cos \theta}$

## Syllabus

### Module 1 (Partial Differential Equations) (8 hours)

(Text 1-Relevant portions of sections 17.1, 17.2, 17.3, 17.4, 17.5, 17.7, 18.1, 18.2)

Partial differential equations, Formation of partial differential equations –elimination of arbitrary constants-elimination of arbitrary functions, Solutions of a partial differential equations, Equations solvable by direct integration, Linear equations of the first order-Lagrange's linear equation, Non-linear equations of the first order -Charpit's method, Solution of equation by method of separation of variables.

### Module 2 (Applications of Partial Differential Equations) (10 hours)

(Text 1-Relevant portions of sections 18.3,18.4, 18.5)

One dimensional wave equation- vibrations of a stretched string, derivation, solution of the wave equation using method of separation of variables, D'Alembert's solution of the wave equation, One dimensional heat equation, derivation, solution of the heat equation

### Module 3 (Complex Variable – Differentiation) (9 hours)

(Text 2: Relevant portions of sections 13.3, 13.4, 17.1, 17.2, 17.4)

Complex function, limit, continuity, derivative, analytic functions, Cauchy-Riemann equations, harmonic functions, finding harmonic conjugate, Conformal mappings- mappings  $w = z^2$ ,  $w = e^z$ ,. Linear fractional transformation  $w = \frac{1}{z}$ , fixed points, Transformation  $w = \sin z$

(From sections 17.1, 17.2 and 17.4 only mappings  $w = z^2$ ,  $w = e^z$ ,  $w = \frac{1}{z}$ ,  $w = \sin z$  and problems based on these transformation need to be discussed)

### Module 4 (Complex Variable – Integration) (9 hours)

(Text 2- Relevant topics from sections 14.1, 14.2, 14.3, 14.4,15.4)

Complex integration, Line integrals in the complex plane, Basic properties, First evaluation method-indefinite integration and substitution of limit, second evaluation method-use of a representation of a path, Contour integrals, Cauchy integral theorem (without proof) on simply connected domain, Cauchy integral theorem (without proof) on multiply connected domain Cauchy Integral formula (without proof), Cauchy Integral formula for derivatives of an analytic function, Taylor's series and Maclaurin series.,

### Module 5 (Complex Variable – Residue Integration) (9 hours)

(Text 2- Relevant topics from sections 16.1, 16.2, 16.3, 16.4 )

Laurent's series(without proof), zeros of analytic functions, singularities, poles, removable singularities, essential singularities, Residues, Cauchy Residue theorem (without proof), Evaluation of definite integral using residue theorem, Residue integration of real integrals – integrals of rational functions of  $\cos\theta$  and  $\sin\theta$ , integrals of improper integrals of the form

$\int_{-\infty}^{\infty} f(x) dx$  with no poles on the real axis. ( $\int_A^B f(x) dx$  whose integrand become infinite at a point in the interval of integration is excluded from the syllabus),

**Textbooks:**

1. B.S. Grewal, Higher Engineering Mathematics, Khanna Publishers, 44<sup>th</sup> Edition, 2018.
2. Erwin Kreyszig, Advanced Engineering Mathematics, 10<sup>th</sup> Edition, John Wiley & Sons, 2016.

**References:**

1. Peter V. O'Neil, Advanced Engineering Mathematics, Cengage, 7<sup>th</sup> Edition, 2012

**Assignments**

**Assignment:** Assignment must include applications of the above theory in the concerned engineering branches

**Course Contents and Lecture Schedule**

No	Topic	No. of Lectures
<b>1</b>	<b>Partial Differential Equations</b>	
1.1	Partial differential equations, Formation of partial differential equations –elimination of arbitrary constants-elimination of arbitrary functions, Solutions of a partial differential equations, Equations solvable by direct integration,	3
1.2	Linear equations of the first order- Lagrange’s linear equation, Non-linear equations of the first order - Charpit’s method	3
1.3	Boundary value problems, Method of separation of variables.	2
<b>2</b>	<b>Applications of Partial Differential Equations</b>	
2.1	One dimensional wave equation- vibrations of a stretched string, derivation,	1
2.2	Solution of wave equation using method of separation of variables, Fourier series solution of boundary value problems involving wave equation, D’Alembert’s solution of the wave equation	4
2.3	One dimensional heat equation, derivation,	1
2.4	Solution of the heat equation, using method of separation of variables, Fourier series solutions of boundary value problems involving heat equation	4

<b>3</b>	<b>Complex Variable – Differentiation</b>	
3.1	Complex function, limit, continuity, derivative, analytic functions, Cauchy-Riemann equations,	4
3.2	harmonic functions, finding harmonic conjugate,	2
3.3	Conformal mappings- mappings of $w = z^2$ , $w = e^z$ , $w = \frac{1}{z}$ , $w = \sin z$ .	3
<b>4</b>	<b>Complex Variable – Integration</b>	
4.1	Complex integration, Line integrals in the complex plane, Basic properties, First evaluation method, second evaluation method, use of representation of a path	4
4.2	Contour integrals, Cauchy integral theorem ( <b>without proof</b> ) on simply connected domain, on multiply connected domain ( <b>without proof</b> ). Cauchy Integral formula ( <b>without proof</b> ),	2
4.3	Cauchy Integral formula for derivatives of an analytic function,	2
4.3	Taylor's series and Maclaurin series.	1
<b>5</b>	<b>Complex Variable – Residue Integration</b>	
5.1	Laurent's series ( <b>without proof</b> )	2
5.2	zeros of analytic functions, singularities, poles, removable singularities, essential singularities, Residues,	2
5.3	Cauchy Residue theorem ( <b>without proof</b> ), Evaluation of definite integral using residue theorem	2
5.4	Residue integration of real integrals – integrals of rational functions of $\cos\theta$ and $\sin\theta$ , integrals of improper integrals of the form $\int_{-\infty}^{\infty} f(x) dx$ with no poles on the real axis. ( $\int_A^B f(x) dx$ whose integrand become infinite at a point in the interval of integration is excluded from the syllabus),	3



Model Question Paper

(For all branches except Computer Science and Information Technology)

(2019 Scheme)

Reg No:

Name:

THIRD SEMESTER B.TECH. DEGREE EXAMINATION

(MONTH & YEAR)

Course Code:

Course Name: PARTIAL DIFFERENTIAL EQUATIONS AND COMPLEX ANALYSIS

MAX.MARKS: 100

DURATION: 3 Hours

**PART A**

**Answer all questions, each carries 3 marks.**

1. Derive a partial differential equation from the relation  $z = f(x + at) + g(x - at)$
2. Solve  $\frac{\partial^2 z}{\partial x \partial y} = x^2 y$
3. State any three assumptions in deriving the one dimensional wave equation
4. What are the possible solutions of one-dimensional heat equation?
5. If  $f(z) = u + iv$  is analytic, then show that  $u$  and  $v$  are harmonic functions.
6. Check whether  $f(z) = \bar{z}$  is analytic or not.
7. Evaluate  $\int_c \tan z dz$  where  $c$  is the unit circle.
8. Find the Taylor's series of  $f(z) = \frac{1}{z}$  about  $z = 2$ .
9. What type of singularity have the function  $f(z) = \frac{1}{\cos z - \sin z}$
10. Find the residue of  $\frac{e^z}{z^3}$  at its pole.

**PART B**

**Answer any one full question from each module, each question carries 14 marks.**

**Module-I**

11. (a) Solve  $x(y - z)p + y(z - x)q = z(x - y)$   
(b) Use Charpit's methods to solve  $q + xp = p^2$
12. (a) Find the differential equation of all spheres of fixed radius having their centers in the  $xy$ -plane.

- (b) Using the method of separation of variables, solve  $\frac{\partial u}{\partial x} = 2 \frac{\partial u}{\partial t} + u$ , where  $u(x, 0) = 6e^{-3x}$ .

**Module – II**

13. (a) Derive the solution of one dimensional wave equation  $\frac{\partial^2 u}{\partial t^2} = c^2 \frac{\partial^2 u}{\partial x^2}$  with zero boundary conditions and with initial conditions  $u(x, 0) = f(x)$  and  $\left(\frac{\partial u}{\partial t}\right)_{t=0} = 0$ .  
 (b) A homogeneous rod of conducting material of length 100 cm has its ends kept at zero temperature and the temperature initially is  $u(x, 0) = \begin{cases} x, & 0 \leq x \leq 50 \\ 100 - x, & 50 \leq x \leq 100 \end{cases}$ . Find the temperature  $u(x, t)$  at any time.
14. (a) A tightly stretched string of length  $l$  with fixed ends is initially in equilibrium position. It is set vibrating by giving each point a velocity  $v_0 \sin^3\left(\frac{\pi x}{l}\right)$ . Find the displacement of the string at any time.  
 (b) An insulated rod of length  $l$  has its ends A and B are maintained at  $0^\circ\text{C}$  and  $100^\circ\text{C}$  respectively under steady state condition prevails. If the temperature at B is suddenly reduced to  $0^\circ\text{C}$  and maintained at  $0^\circ\text{C}$ , Find the temperature at a distance  $x$  from A at time  $t$ .

**Module-III**

15. (a) Show that  $f(z) = e^z$  is analytic for all  $z$ . Find its derivative.  
 (b) Find the image of  $|z - 2i| = 2$  under the transformation  $w = \frac{1}{z}$
16. (a) Prove that the function  $u(x, y) = x^3 - 3xy^2 - 5y$  is harmonic everywhere. Find its harmonic conjugate.  
 (b) Find the image of the infinite stripe  $0 \leq y \leq \pi$  under the transformation  $w = e^z$

**Module-IV**

17. (a) Evaluate  $\int_0^{2+i} (\bar{z})^2 dz$ , along the real axis to 2 and then vertically to  $2 + i$   
 (b) Using Cauchy's integral formula evaluate  $\int_C \frac{5z+7}{z^2+2z-3} dz$ , where  $C$  is  $|z - 2| = 2$
18. (a) Evaluate  $\int_C \frac{\sin^2 z}{\left(z - \frac{\pi}{6}\right)^3} dz$ , where  $C$  is  $|z| = 1$ .  
 (b) Expand  $\frac{1}{(z-1)(z-2)}$  in the region  $|z| < 1$

**Module- V**

19. (a) Expand  $f(z) = \frac{z^2-1}{z^2-5z+6}$  in  $2 < |z| < 3$  as a Laurent's series.  
 (b) Using contour integration evaluate  $\int_0^{2\pi} \frac{d\theta}{2+\cos \theta}$
20. (a) Use residue theorem to evaluate  $\int_C \frac{\cos h \pi z}{z^2+4} dz$  where  $C$  is  $|z| = 3$ .  
 (b) Apply calculus of residues to evaluate  $\int_{-\infty}^{\infty} \frac{1}{(x^2+1)^3} dx$ .



## Assessment Pattern

Bloom's Category	Continuous Assessment Tests		End Semester Examination
	1	2	
Remember	10	10	20
Understand	20	20	30
Apply	20	20	50
Analyse			
Evaluate			
Create			

## Mark distribution

Total Marks	CIE	ESE	ESE Duration
150	50	100	3 hours

### Continuous Internal Evaluation Pattern:

Attendance	: 10 marks
Continuous Assessment Test (2 numbers)	: 25 marks
Assignment/Quiz/Course project	: 15 marks

### End Semester Examination Pattern:

There will be two parts; Part A and Part B. Part A contain 10 questions with 2 questions from each module and having 3 marks for each question. Students should answer all questions. Part B contains 2 questions from each module of which student should answer any one. Each question carries 14 marks and can have a maximum of 2 subdivisions.

## COURSE LEVEL ASSESSMENT QUESTIONS

### Course Outcome 1 (CO1):

1. Determine the resultant traction at a point in a plane using the stress tensor.
2. Evaluate the principal stresses, principal strains and their directions from a given state of stress or strain.
3. Write the stress tensor and strain tensor.

### Course Outcome 2 (CO2)

1. Write the generalized Hooke's law for stress-strain relations.
2. Estimate the state of strain from a given state of stress.
3. Analyse the strength of a structure subjected to thermal loading.

### Course Outcome 3(CO3):

1. Design a shaft to transmit power and torque.
2. Draw the shear force and bending moment diagrams.
3. Determine the bending stress on a beam subjected to pure bending.

### Course Outcome 4 (CO4):

1. Apply strain energy method to estimate the deformation of a structure.
2. Use strain energy method to calculate deformations for multiple loads.
3. Use strain energy method to estimate the loads acting on a structure for a maximum deflection.

### Course Outcome 5 (CO5):

1. Analyse a column for buckling load.
2. Use Rankine formula to determine the crippling load of columns.
3. A bolt is subjected to a direct tensile load of 20 kN and a shear load of 15 kN. Suggest suitable size of this bolt according to various theories of elastic failure, if the yield stress in simple tension is 360 MPa. A factor of safety 2 should be used. Assume Poisson's ratio as 0.3.

# SYLLABUS

## Module 1

Deformation behaviour of elastic solids in equilibrium under the action of a system of forces, method of sections. Stress vectors on Cartesian coordinate planes passing through a point, stress at a point in the form of a matrix. Equality of cross shear, Cauchy's equation. Displacement, gradient of displacement, Cartesian strain matrix, strain- displacement relations (small-strain only), Simple problems to find strain matrix. Stress tensor and strain tensor for plane stress and plane strain conditions. Principal planes and principal stress, meaning of stress invariants, maximum shear stress. Mohr's circle for 2D case.

## Module 2

Stress-strain diagram, Stress–Strain curves of Ductile and Brittle Materials, Poisson's ratio. Constitutive equations-generalized Hooke's law, equations for linear elastic isotropic solids in terms of Young's Modulus and Poisson's ratio, Hooke's law for Plane stress and plane strain conditions Relations between elastic constants  $E$ ,  $G$ ,  $\nu$  and  $K$ (derivation not required). Calculation of stress, strain and change in length in axially loaded members with single and composite materials, Effects of thermal loading – thermal stress and thermal strain. Thermal stress on a prismatic bar held between fixed supports.

## Module 3

Torsional deformation of circular shafts, assumptions for shafts subjected to torsion within elastic deformation range, derivation of torsion formula Torsional rigidity, Polar moment of inertia, basic design of transmission shafts. Simple problems to estimate the stress in solid and hollow shafts. Shear force and bending moment diagrams for cantilever and simply supported beams. Differential equations between load, shear force and bending moment. Normal and shear stress in beams: Derivation of flexural formula, section modulus, flexural rigidity, numerical problems to evaluate bending stress, economic sections. Shear stress formula for beams: (Derivation not required), shear stress distribution for a rectangular section.

## Module 4

Deflection of beams using Macauley's method  
Elastic strain energy and Complementary strain energy. Elastic strain energy for axial loading, transverse shear, bending and torsional loads. Expressions for strain energy in terms of load, geometry and material properties of the body for axial, shearing, bending and torsional loads. Castigliano's second theorem, reciprocal relation(Proof not required for Castigliano's second theorem, reciprocal relation).  
Simple problems to find the deflections using Castigliano's theorem.

## Module 5

Fundamentals of buckling and stability, critical load, equilibrium diagram for buckling of an idealized structure. Buckling of columns with pinned ends, Euler's buckling theory for long columns. Critical stress, slenderness ratio, Rankine's formula for short columns.  
Introduction to Theories of Failure, Rankine's theory for maximum normal stress, Guest's theory for maximum shear stress, Saint-Venant's theory for maximum normal strain, Hencky-von Mises theory for maximum distortion energy, Haigh's theory for maximum strain energy

## Text Books

1. Mechanics of materials in S.I. Units, R .C. Hibbeler, Pearson Higher Education 2018
2. Advanced Mechanics of Solids, L. S. Srinath, McGraw Hill Education

3. Design of Machine Elements, V. B Bhandari, McGraw Hill Education

### **Reference Books**

1. Engineering Mechanics of Solids, Popov E., PHI 2002

2. Mechanics of Materials S. I. units, Beer, Johnston, Dewolf, McGraw Hills 2017

3. Mechanics of Materials, Pytel A. and Kiusalaas J. Cengage Learning India Private Limited, 2<sup>nd</sup> Edition, 2015

4. Strength of Materials, Rattan, McGraw Hills 2011

5. Strength of Materials, Surendra Singh, S. K. Kataria & Sons

## COURSE PLAN

No	Topic	No of lectures
<b>1</b>	<b>Module 1: Stress and Strain Analysis</b>	<b>9 hours</b>
1.1	Describe the deformation behaviour of elastic solids in equilibrium under the action of a system of forces. Describe method of sections to illustrate stress as resisting force per unit area. Stress vectors on Cartesian coordinate planes passing through a point and writing stress at a point in the form of a matrix.	2 hr
1.2	Equality of cross shear (Derivation not required). Write Cauchy's equation (Derivation not required), Find resultant stress, Normal and shear stress on a plane given stress tensor and direction cosines (no questions for finding direction cosines).	2 hr
1.3	Displacement, gradient of displacement, Cartesian strain matrix, Write strain-displacement relations (small-strain only), Simple problems to find strain matrix given displacement field (2D and 3D), write stress tensor and strain tensor for Plane stress and plane strain conditions.	1 hr
1.4	Concepts of principal planes and principal stress, characteristic equation of stress matrix and evaluation of principal stresses and principal planes as an eigen value problem, meaning of stress invariants, maximum shear stress	2 hrs
1.5	Mohr's circle for 2D case: find principal stress, planes, stress on an arbitrary plane, maximum shear stress graphically using Mohr's circle	2 hrs
<b>2</b>	<b>Module 2: Stress - Strain Relationships</b>	<b>9 hours</b>
2.1	Stress-strain diagram, Stress-Strain curves of Ductile and Brittle Materials, Poisson's ratio	1 hr
2.2	Constitutive equations-generalized Hooke's law, equations for linear elastic isotropic solids in terms of Young's Modulus and Poisson's ratio (3D). Hooke's law for Plane stress and plane strain conditions Relations between elastic constants E, G, $\nu$ and K(derivation not required), Numerical problems	2 hrs
2.3	Calculation of stress, strain and change in length in axially loaded members with single and composite materials, Effects of thermal loading – thermal stress and thermal strain. Thermal stress on a prismatic bar held between fixed supports.	2 hrs
2.4	Numerical problems for axially loaded members	4 hrs
<b>3</b>	<b>Module 3: Torsion of circular shafts, Shear Force-Bending Moment Diagrams and Pure bending</b>	<b>9 hours</b>
3.1	Torsional deformation of circular shafts, assumptions for shafts subjected to torsion within elastic deformation range, derivation of torsion formula	1 hr
3.2	Torsional rigidity, Polar moment of inertia, comparison of solid and hollow shaft. Simple problems to estimate the stress in solid and hollow shafts	1 hr
3.3	Numerical problems for basic design of circular shafts subjected to externally applied torques	1 hr
3.4	Shear force and bending moment diagrams for cantilever and simply	2 hrs



	supported beams subjected to point load, moment, UDL and linearly varying load	
3.5	Differential equations between load, shear force and bending moment.	1 hr
3.6	Normal and shear stress in beams: Derivation of flexural formula, section modulus, flexural rigidity, numerical problems to evaluate bending stress, economic sections Shear stress formula for beams: (Derivation not required), numerical problem to find shear stress distribution for rectangular section	3 hrs
<b>4</b>	<b>Module 4: Deflection of beams, Strain energy</b>	<b>8 hours</b>
4.1	Deflection of cantilever and simply supported beams subjected to point load, moment and UDL using Macauley's method (procedure and problems with multiple loads)	2 hrs
4.2	Linear elastic loading, elastic strain energy and Complementary strain energy. Elastic strain energy for axial loading, transverse shear, bending and torsional loads (short derivations in terms of loads and deflections).	2 hr
4.3	Expressions for strain energy in terms of load, geometry and material properties of the body for axial, shearing, bending and torsional loads. Simple problems to solve elastic deformations	2 hrs
4.4	Castigliano's second theorem to find displacements, reciprocal relation, (Proof not required for Castigliano's second theorem and reciprocal relation).	1 hr
4.5	Simple problems to find the deflections using Castigliano's theorem	1 hr
<b>5</b>	<b>Module 5: Buckling of Columns, Theories of Failure</b>	<b>8 hours</b>
5.1	Fundamentals of bucking and stability, critical load, Euler's formula for long columns, assumptions and limitations, effect of end conditions(derivation only for pinned ends), equivalent length	2 hr
5.2	Critical stress, slenderness ratio, Rankine's formula for short columns, Problems	3 hr
5.3	Introduction to Theories of Failure. Rankine's theory for maximum normal stress, Guest's theory for maximum shear stress, Saint-Venant's theory for maximum normal strain	2 hr
5.4	Hencky-von Mises theory for maximum distortion energy, Haigh's theory for maximum strain energy	1 hr

## MODEL QUESTION PAPER

THIRD SEMESTER B.TECH DEGREE EXAMINATION

Course Code : MET201

Course Name : MECHANICS OF SOLIDS

Max. Marks : 100

Duration : 3 Hours

### PART – A

**(ANSWER ALL QUESTIONS, EACH QUESTION CARRIES 3 MARKS)**

1. Express the stress invariants in terms of Cartesian components of stress and principal stress.
2. Write down the Cauchy's strain displacement relationships.
3. Distinguish between the states of plane stress and plane strain.
4. Explain the generalized Hooke's law for a Linear elastic isotropic material.
5. List any three important assumptions in the theory of torsion.
6. Write the significance of flexural rigidity and section modulus in the analysis of beams.
7. Discuss reciprocal relation for multiple loads on a structure.
8. Express the strain energy for a cantilever beam subjected to a transverse point load at free end.
9. Discuss Saint-Venant's theory of failure.
10. Explain the term 'critical load' with reference to the buckling of slender columns.

### PART – B

**(ANSWER ONE FULL QUESTION FROM EACH MODULE)**

#### MODULE – 1

11. a) The state of stress at a point is given by  $\sigma_{xx} = 12.31$  MPa,  $\sigma_{yy} = 8.96$  MPa,  $\sigma_{zz} = 4.34$  MPa,  $\tau_{xy} = 4.2$  MPa,  $\tau_{yz} = 5.27$  MPa,  $\tau_{xz} = 0.84$  MPa. Determine the principal stresses. (7 marks)  
b) The displacement field for a body is given by  $\mathbf{u} = (x^2 + y)\mathbf{i} + (3 + z)\mathbf{j} + (x^2 + 2y)\mathbf{k}$ . What is the deformed position of a point originally at (3,1,-2)? Write the strain tensor at the point (-3,-1,2). (7 marks)

OR

12. a) The state of plane stress at a point is given by  $\sigma_{xx} = 40$  MPa,  $\sigma_{yy} = 20$  MPa and  $\tau_{xy} = 16$  MPa. Using Mohr's circle determine the i) principal stresses and principal planes and ii) maximum shear stress. (7 marks)

b) The state of stress at a point is given below. Find the resultant stress vector acting on a plane with direction cosines  $n_x=0.47$ ,  $n_y=0.82$  and  $n_z=0.33$ . Find the normal and tangential stresses acting on this plane. (7 marks)

$$\sigma_{ij} = \begin{bmatrix} 10 & 5 & -10 \\ 5 & 20 & -15 \\ -10 & -15 & -10 \end{bmatrix} \text{MPa}$$

MODULE – 2

13. a) Calculate Modulus of Rigidity and Young's Modulus of a cylindrical bar of diameter 30 mm and of 1.5 m length if the longitudinal strain in a bar during a tensile stress is four times the lateral strain. Find the change in volume when the bar is subjected to a hydrostatic pressure of 100 N/mm<sup>2</sup>. Take  $E = 10^5$  N/mm (9 marks)

b) A straight bar 450 mm long is 40 mm in diameter for the first 250 mm length and 20 mm diameter for the remaining length. If the bar is subjected to an axial pull of 15 kN find the maximum axial stress produced and the total extension of the bar. Take  $E = 2 \times 10^5$  N/mm<sup>2</sup> (5 marks)

OR

14. a) A brass bar 20mm diameter is enclosed in a steel tube of 25mm internal diameter and 50mm external diameter. Both bar and tube is of same length and fastened rigidly at their ends. The composite bar is free of stress at 20°C. To what temperature the assembly must be heated to generate a compressive stress of 48MPa in brass bar? Also determine the stress in steel tube.  $E_{\text{steel}} = 200\text{GPa}$  and  $E_{\text{brass}} = 84\text{GPa}$ ,  $\alpha_{\text{steel}} = 12 \times 10^{-6} / ^\circ\text{C}$  and  $\alpha_{\text{brass}} = 18 \times 10^{-6} / ^\circ\text{C}$ . (9 marks)

b) Draw the stress-strain diagram for a ductile material and explain the salient points. (5 marks)

MODULE – 3

15. a) Draw shear force and bending moment diagram for the beam given in the figure. (9 marks)

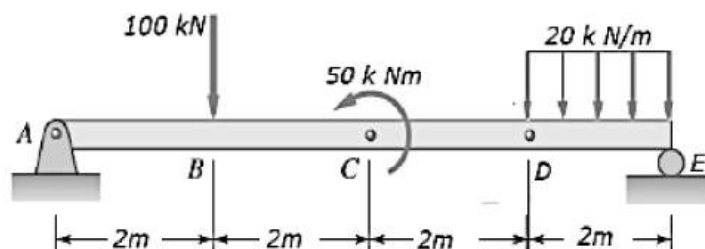

b) Compare the strength of a hollow shaft of diameter ratio 0.75 to that of a solid shaft by considering the permissible shear stress. Both the shafts are of same material, of same length and weight. (5 marks)

OR

16. a) A simply supported beam of span of 10 m carries a UDL of 40 kN/m. The cross section is of I shape as given below. Calculate the maximum stress produced due to bending and plot the bending stress distribution. (9 marks)

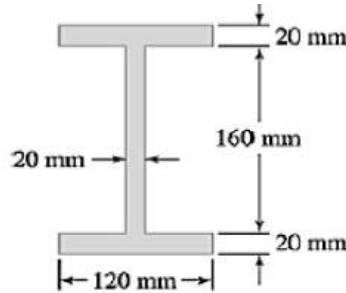

- b) The shear stress of a solid shaft is not to exceed  $40 \text{ N/mm}^2$  when the power transmitted is 20 kW at 200 rpm. Determine the minimum diameter of the shaft. (5 marks)

#### MODULE – 4

17. a) A horizontal girder of steel having uniform section is 14 m long and is simply supported at its ends. It carries concentrated loads of 120 kN and 80 kN at two points 3 m and 4.5 m from the two ends respectively. Moment of inertia for the section of the girder is  $16 \times 10^8 \text{ mm}^4$  and  $E_s = 210 \text{ kN/mm}^2$ . Calculate the deflection of the girder at points under the two loads and maximum deflection using Macaulay's method. (8 marks)
- b) Derive the expressions for elastic strain energy in terms of applied load/moment and material property for the cases of a) Axial force b) Bending moment. (6 marks)

OR

18. a) Calculate the displacement in the direction of load P applied at a distance of  $L/3$  from the left end for a simply supported beam of span L as shown in the figure.

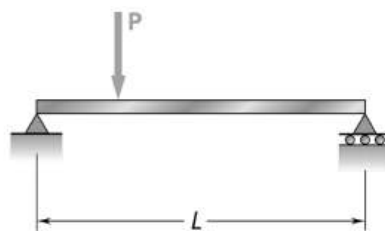

(10 marks)

- b) State Castigliano's second theorem and explain its significance. (4 marks)

#### MODULE – 5

19. a) Find the crippling load for a hollow steel column 50mm internal diameter and 5mm thick. The column is 5m long with one end fixed and other end hinged. Use Rankine's formula and Rankine's constant as  $1/7500$  and  $\sigma_c = 335 \text{ N/mm}^2$ . Compare this load by crippling load given by Euler's formula. Take  $E = 110 \text{ GPa}$ . (8 marks)

b) Explain the maximum normal stress theory, maximum strain energy theory and maximum shear stress theory of failure. (6 marks)

OR

20. a) The principal stresses at a point in an elastic material are  $22 \text{ N/mm}^2$  (tensile),  $110 \text{ N/mm}^2$  (tensile) and  $55 \text{ N/mm}^2$  (compressive). If the elastic limit in simple tension is  $210 \text{ N/mm}^2$ , then determine whether the failure of material will occur or not according to Maximum principal stress theory, Maximum shear stress theory and maximum distortion energy theory.

(9 marks)

b) Derive Euler's formula for a column with both ends hinged.

(5 marks)

COURSE CODE	COURSE NAME	CATEGORY	L	T	P	CREDITS
22MET303	MECHANICS OF FLUIDS	ES	3	1	0	4

**Preamble :**

This course provides an introduction to the properties and behaviour of fluids. It enables to apply the concepts in engineering, pipe networks. It introduces the concepts of boundary layers, dimensional analysis and model testing

**Prerequisite :** NIL

**Course Outcomes :**

After completion of the course the student will be able to

CO1	Define Properties of Fluids and Solve hydrostatic problems
CO2	Explain fluid kinematics and Classify fluid flows
CO3	Interpret Euler and Navier-Stokes equations and Solve problems using Bernoulli's equation
CO4	Evaluate energy losses in pipes and sketch energy gradient lines
CO5	Explain the concept of boundary layer and its applications
CO6	Use dimensional Analysis for model studies

**Mapping of course outcomes with program outcomes**

	PO1	PO2	PO3	PO4	PO5	PO6	PO7	PO8	PO9	PO10	PO11	PO12
CO1	3	2										
CO2	3	2	1									
CO3	3	2	1									
CO4	3	3	2									
CO5	3	2	1									
CO6	3	2	1									

**Assessment Pattern**

Blooms Category	CA			ESA
	Assignment	Test - 1	Test - 2	
Remember	25	20	20	10
Understand	25	40	40	20
Apply	25	40	40	70
Analyse	25			
Evaluate				
Create				

**Continuous Internal Evaluation Pattern:**

Attendance : 10 marks

Continuous Assessment Test (2 numbers) : 25 marks

Assignment/Quiz/Course project : 15 marks

**Mark distribution & Duration of Examination :**

Total Marks	CA	ESE	ESE Duration
150	50	100	3 Hours

**End semester pattern:**

There will be two parts; Part A and Part B. Part A contain 10 questions with 2 questions from each module, having 3 marks for each question. Students should answer all questions. Part B contains 2 questions from each module of which student should answer any one. Each question can have maximum 2 sub-divisions and carry 14 marks.

## COURSE LEVEL ASSESSMENT QUESTIONS

### Course Outcome 1

1. A  $3.6 \times 1.5$  m wide rectangular gate MN is vertical and is hinged at point 0.15 m below the center of gravity of the gate. The total depth of water is 6 m. What horizontal force must be applied at the bottom of the gate to keep the gate closed.

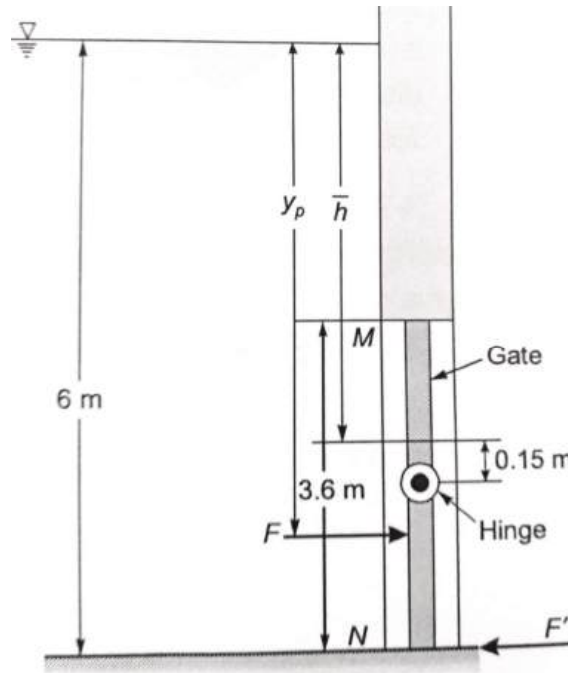

2. A stationary liquid is stratified so that its density is  $\rho_0(1 + h)$  at a depth  $h$  below the free surface. At a depth  $h$  in this liquid, what is the pressure in excess of  $\rho_0gh$ ?
3. If the velocity profile of a fluid is parabolic with free stream velocity 120 cm/s occurring at 20 cm from the plate, calculate the velocity gradients and shear stress at a distance of 0, 10, 20 cm from the plate. Take the viscosity of fluid as 8.5 poise.

### Course Outcome 2

1. Differentiate between the Eulerian and Lagrangian method of representing fluid motion.
2. A velocity field is given by  $u = 3y^2$ ,  $v = 2x$  and  $w = 0$  in arbitrary units. Is this flow steady or unsteady? Is it two or three dimensional? At  $(x,y,z)=(2,1,0)$ , compute
  - (a) velocity
  - (b) local acceleration
  - (c) convective acceleration
3. A stream function in two dimensional flow is  $\psi = 2xy$ . Show that the flow is irrotational and determine the corresponding velocity potential  $\phi$ .



### Course Outcome 3

1. A siphon consisting of a pipe of 15 cm diameter is used to empty kerosene oil (relative density=0.8) from tank A. The siphon discharges to the atmosphere at an elevation of 1.00 m. The oil surface in the tank is at an elevation of 4.00 m. The center line of the siphon pipe at its highest point C is at an elevation of 5.50 m. Estimate,

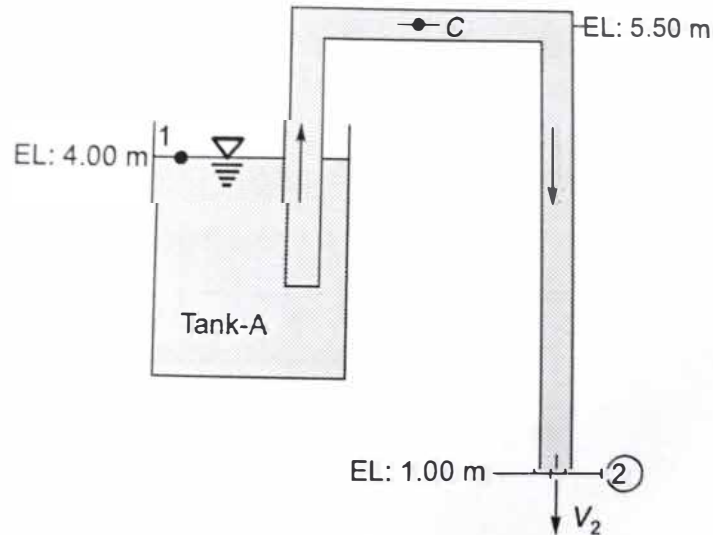

- (a) Discharge in the pipe
- (b) Pressure at point C.

The losses in the pipe can be assumed to be 0.5 m up to the summit and 1.2 m from summit to the outlet.

2. Derive the Euler's equation of motion along a streamline and from that derive the Bernouli's equation.
3. What is water hammer? Explain different cases of water hammer. Derive the expression for pressure rise in any one of the case.

### Course Outcome 4

1. Two reservoir with a difference in water surface elevation of 10 m are connected by a pipeline AB and BC joined in series. Pipe AB is 10 cm in diameter, 20 m long and has a value of friction factor  $f = 0.02$ . Pipe BC is 16 cm diameter, 25 m long and has a friction factor  $f=0.018$ . The junctions with reservoirs and between pipes are abrupt.
  - (a) Sketch Total energy line and Hydraulic gradient line
  - (b) Calculate the discharge.
2. Oil of viscosity 0.1 Pas and specific gravity 0.9 flows through a horizontal pipe of 25 mm diameter. If the pressure drop per meter length of the pipe is 12 KPa, determine
  - (a) Discharge through the pipe
  - (b) Shear stress at the pipe wall
  - (c) Reynolds number of the flow

(d) Power required in Watts if the length of the pipe is 50m

3. In a hydraulic power plant, a reinforced concrete pipe of diameter  $D$  is used to transmit water from the reservoir to the turbine. If  $H$  is the total head supply at the entrance of the pipe and  $h_f$  is the loss of head in the pipe, then derive the condition for maximum power supply through the pipe.

### Course Outcome 5

1. Write a short note on boundary layer separation and discuss any two methods to control the same.
2. Find the displacement thickness, momentum thickness and energy thickness for velocity distribution in boundary layer given by

$$\frac{u}{U_\infty} = 2 \left( \frac{y}{\delta} \right) - \left( \frac{y}{\delta} \right)^2$$

3. A thin plate is moving in still atmospheric air at a velocity of 4m/s. The length of the plate is 0.5 m and width 0.4 m. Calculate the
  - (a) thickness of the boundary layer at the end of the plate and
  - (b) drag force on one side of the plate.

Take density of air as  $1.25 \text{ kg/m}^3$  and kinematic viscosity  $0.15 \text{ stokes}$ .

### Course Outcome 6

1. State and explain Buckingham's pi theorem.
2. An underwater device is 1.5m long and is to move at 3.5 m/s speed. A geometrically similar model 30 cm long is tested in a variable pressure wind tunnel at a speed of 35 m/s. Calculate the pressure of air in the model if the model experience a drag force of 40 N, calculate the prototype drag force. [Assume density of water =  $998 \text{ kg/m}^3$ , density of air at standard atmospheric pressure =  $1.17 \text{ kg/m}^3$ , dynamic viscosity of air at local atmospheric pressure =  $1.95 * 10^{-5} \text{ Pas}$  and dynamic viscosity of water =  $1 * 10^{-3} \text{ Pas}$ ]
3. Explain the importance of dimensionless numbers and discuss any two similarity laws. Where are these model laws used?

# SYLLABUS

**Module 1:** Introduction: Fluids and continuum, Physical properties of fluids, density, specific weight, vapour pressure, Newton's law of viscosity. Ideal and real fluids, Newtonian and non-Newtonian fluids. Fluid Statics- Pressure-density-height relationship, manometers, pressure on plane and curved surfaces, center of pressure, buoyancy, stability of immersed and floating bodies, fluid masses subjected to uniform accelerations, measurement of pressure.

**Module 2:** Kinematics of fluid flow: Eulerian and Lagrangian approaches, classification of fluid flow, 1-D, 2-D and 3-D flow, steady, unsteady, uniform, non-uniform, laminar, turbulent, rotational, irrotational flows, stream lines, path lines, streak lines, stream tubes, velocity and acceleration in fluid, circulation and vorticity, stream function and potential function, Laplace equation, equipotential lines, flow nets, uses and limitations.

**Module 3:** Control volume analysis of mass, momentum and energy, Equations of fluid dynamics: Differential equations of mass, energy and momentum (Euler's equation), Navier-Stokes equations (without proof) in cartesian co-ordinates. Dynamics of Fluid flow: Bernoulli's equation, Energies in flowing fluid, head, pressure, dynamic, static and total head, Venturi and Orifice meters, Notches and Weirs (description only for notches and weirs). Hydraulic coefficients, Velocity measurements: Pitot tube and Pitot-static tube.

**Module 4:** Pipe Flow: Viscous flow: Reynolds experiment to classify laminar and turbulent flows, significance of Reynolds number, critical Reynolds number, shear stress and velocity distribution in a pipe, law of fluid friction, head loss due to friction, Hagen Poiseuille equation. Turbulent flow: Darcy-Weisbach equation, Chezy's equation Moody's chart, Major and minor energy losses, hydraulic gradient and total energy line, flow through long pipes, pipes in series, pipes in parallel, equivalent pipe, siphon, transmission of power through pipes, efficiency of transmission, Water hammer, Cavitation.

**Module 5:** Boundary Layer : Growth of boundary layer over a flat plate and definition of boundary layer thickness, displacement thickness, momentum thickness and energy thickness, laminar and turbulent boundary layers, laminar sub layer, velocity profile, Von- Karman momentum integral equations for the boundary layers, calculation of drag, separation of boundary and methods of control. Dimensional Analysis: Dimensional analysis, Buckingham's theorem, important non dimensional numbers and their significance, geometric, Kinematic and dynamic similarity, model studies. Froude, Reynolds, Weber, Cauchy and Mach laws- Applications and limitations of model testing, simple problems only

## Text Books

John. M. Cimbala and Yunus A. Cengel, Fluid Mechanics: Fundamentals and Applications (4<sup>th</sup> edition, SIE), 2019

Robert W. Fox, Alan T. McDonald, Philip J. Pritchard and John W. Mitchell, Fluid Mechanics, Wiley India, 2018

## Reference Books

White, F. M., Fluid Mechanics, McGraw Hill Education India Private Limited, 8<sup>th</sup> Edition, 2017

Rathakrishnan, E. Fluid Mechanics: An Introduction, Prentice Hall India, 3<sup>rd</sup> Edition 2012

## COURSE PLAN

Module	Topics	Hours Allotted
I	Introduction: Fluids and continuum, Physical properties of fluids, density, specific weight, vapour pressure, Newton's law of viscosity. Ideal and real fluids, Newtonian and non-Newtonian fluids. Fluid Statics- Pressure-density-height relationship, manometers, pressure on plane and curved surfaces, center of pressure, buoyancy, stability of immersed and floating bodies, fluid masses subjected to uniform accelerations, measurement of pressure.	7-2-0
II	Kinematics of fluid flow: Eulerian and Lagrangian approaches, classification of fluid flow, 1-D, 2-D and 3-D flow, steady, unsteady, uniform, non-uniform, laminar, turbulent, rotational, irrotational flows, stream lines, path lines, streak lines, stream tubes, velocity and acceleration in fluid, circulation and vorticity, stream function and potential function, Laplace equation, equipotential lines, flow nets, uses and limitations.	6-2-0
III	Control volume analysis of mass, momentum and energy, Equations of fluid dynamics: Differential equations of mass, energy and momentum (Euler's equation), Navier-Stokes equations (without proof) in cartesian co-ordinates Dynamics of Fluid flow: Bernoulli's equation, Energies in flowing fluid, head, pressure, dynamic, static and total head, Venturi and Orifice meters, Notches and Weirs (description only for notches and weirs). Hydraulic coefficients, Velocity measurements: Pitot tube and Pitot-static tube.	6-2-0
IV	Pipe Flow: Viscous flow: Reynolds experiment to classify laminar and turbulent flows, significance of Reynolds number, critical Reynolds number, shear stress and velocity distribution in a pipe, law of fluid friction, head	9-3-0

	loss due to friction, Hagen Poiseuille equation. Turbulent flow: Darcy-Weisbach equation, Chezy's equation Moody's chart, Major and minor energy losses, hydraulic gradient and total energy line, flow through long pipes, pipes in series, pipes in parallel, equivalent pipe, siphon, transmission of power through pipes, efficiency of transmission, Water hammer, Cavitation.	
<b>V</b>	Boundary Layer : Growth of boundary layer over a flat plate and definition of boundary layer thickness, displacement thickness, momentum thickness and energy thickness, laminar and turbulent boundary layers, laminar sub layer, velocity profile, Von- Karman momentum integral equations for the boundary layers, calculation of drag, separation of boundary and methods of control. Dimensional Analysis: Dimensional analysis, Buckingham's theorem, important non dimensional numbers and their significance, geometric, Kinematic and dynamic similarity, model studies. Froude, Reynolds, Weber, Cauchy and Mach laws- Applications and limitations of model testing, simple problems only	8-2-0

**MODEL QUESTION PAPER**  
**IV SEMESTER B.TECH DEGREE EXAMINATION**  
**MET203: MECHANICS OF FLUIDS**  
Mechanical Engineering

Maximum: 100 Marks

Duration: 3 hours

**PART A**

Answer all questions, each question carries 3 marks

1. The specific gravity of a liquid is 3.0. What are its specific weight, specific mass and specific volume.
2. State Pascal's law and give some examples where this principle is used.
3. Explain Streamlines, Streaklines and Pathlines.
4. What do you understand by the terms: (i) Total acceleration, (ii) Convective acceleration, and (iii) Local acceleration.
5. Name the different forces present in a fluid flow. For the Euler's equation of motion, which forces are taken into consideration.
6. Differentiate between pitot tube and pitot static tube.
7. Define and explain the terms (i) Hydraulic gradient line and (ii) Total energy line.
8. Show that the coefficient of friction for viscous flow through a circular pipe is given by

$$f = \frac{16}{Re}$$

where  $Re$  is the Reynolds number.

9. What do you mean by repeating variables? How repeating variables are selected for dimensional analysis.
10. How will you determine whether a boundary layer flow is attached flow, detached flow or on the verge of separation.

(10×3=30 Marks)

## PART B

Answer one full question from each module

### MODULE-I

11. (a) Through a very narrow gap of height  $h$ , a thin plate of large extent is pulled at a velocity  $V$ . On one side of the plate is oil of viscosity  $\mu_1$  and on the other side oil of viscosity  $\mu_2$ . Calculate the position of the plate so that
- the shear force on the two sides of the plate is equal.
  - the pull required to drag the plate is minimum.

Assume linear velocity distribution in transverse direction. (7 Marks)

- (b) A metallic cube of 30 cm side and weight 500 N is lowered into a tank containing two fluid layers of water and mercury. Top edge of the cube is at water surface. Determine the position of the block at water mercury interface when it has reached equilibrium. (7 Marks)
12. (a) A rectangular tank 1.5 m wide, 3 m long and 1.8 m deep contains water to a depth of 1.2 m. Find the horizontal acceleration which may be imparted to the tank in the direction of length so that
- there is just no spilling from the tank
  - front bottom corner of the tank is just exposed.

(7 Marks)

- (b) A spherical water drop of 1 mm diameter splits up in air into 64 smaller drops of equal size. Find the work required in splitting up the drop. The surface tension coefficient of water in air =  $0.073 \text{ N/m}$  (7 Marks)

### MODULE-II

13. (a) In a fluid flow field, velocity vector is given by  $v = (0.5 + 8x)i + (0.5 - 0.8y)j$ . Find the equation of streamline for the given velocity field. (7 Marks)
- (b) The stream function  $\psi = 4xy$  in which  $\psi$  is in  $\text{cm}^2/\text{s}$  and  $x$  and  $y$  are in meters describe the incompressible flow between the boundary shown below:

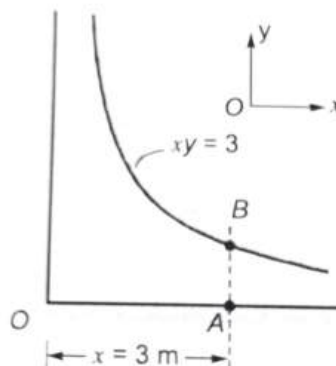

Calculate

- Velocity at B
- Convective acceleration at B

iii. Flow per unit width across AB

(7 Marks)

14. (a) Consider the velocity field given by  $u = x^2$  and  $v = -2xy$ . Find the circulation around the area bounded by  $A(1, 1), B(2, 1), C(2, 2), D(1, 2)$ . (7 Marks)

(b) Verify whether the following are valid potential functions.

i.  $\phi = 2x + 5y$

ii.  $\phi = 4x^2 - 5y^2$

(7 Marks)

### MODULE-III

15. (a) A submarine moves horizontally in sea and has its axis 15 m below the surface of the water. A pitot tube properly placed just in front of the submarine and along its axis is connected to two limbs of a U tube containing mercury. The difference of level is found to be 170 mm. Find the speed of the submarine knowing that the specific gravity of mercury is 13.6 and that of sea water is 1.026 with respect to water. (7 Marks)

(b) A pitot tube is inserted in a pipe of 30 cm diameter. The static pressure of the tube is 10 cm of mercury vacuum. The stagnation pressure at the centre of the pipe recorded by the pitot tube is  $1.0 \text{ N/cm}^2$ . Calculate the rate of flow of water through the pipe, if the mean velocity of flow is 0.85 times central velocity. Assume coefficient of tube as 0.98. (7 Marks)

16. (a) A smooth pipe of uniform diameter 25 cm, a pressure of 50 KPa was observed at section 1 which has an elevation of 10 m. At another section 2, at an elevation of 12 m, the pressure was 20 KPa and the velocity was 1.25 m/s. Determine the direction of flow and the head loss between the two sections. The fluid in the pipe is water. (8 Marks)

(b) Petrol of specific gravity 0.8 is following through a pipe of 30 cm diameter. The pipe is inclined at  $30^\circ$  to horizontal. The venturi has a throat diameter of 10 cm. U tube manometer reads 6.25 cm Hg. Calculate the discharge through the pipe. Assume  $C_d = 0.98$ . (6 Marks)

### MODULE-IV

17. (a) Assuming viscous flow through a circular pipe derive the expression for,

i. Velocity distribution

ii. Shear stress distribution

Also plot the velocity and shear stress distribution.

(7 Marks)

(b) A large tank shown in the figure has a vertical pipe 70 cm long and 2 cm in diameter. The tank contain oil of density  $920 \text{ Kg/m}^3$  and viscosity 1.5 poise. Find the discharge through the tube when the height of oil level of the tank is 0.80 m above the pipe inlet.



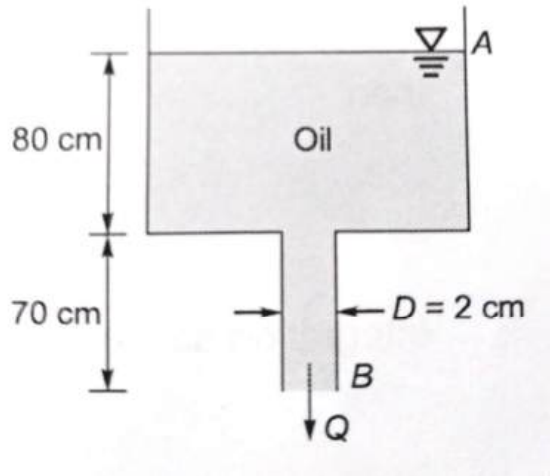

(7 Marks)

18. (a) A compound piping system consist of 1800 m of 50 cm, 1200 m of 40 cm and 600 m of 30 com diameter pipes off same material connected in series.
- What is the equivalent length of a 40 cm pipe of same material?
  - What is the equivalent diameter of a pipe 3600 m long?
  - If three pipes are in parallel what is equivalent length of 50 cm pipe?
- (10 Marks)
- (b) A pipe line of 2100 m is used for transmitting 103 KW. The pressure at the inlet of the pipe is  $392.4 \text{ N/cm}^2$ . If the efficiency of transmission is 80%, find the diameter of the pipe. Take  $f = 0.005$ . (4 Marks)

### MODULE-V

19. (a) The velocity profile  $u$  of a boundary layer flow over a flat plate is given by

$$\frac{u}{U_{\infty}} = \frac{3}{2} \left( \frac{y}{\delta} \right) - \frac{1}{2} \left( \frac{y}{\delta} \right)^3$$

If the boundary thickness is given as

$$\delta = \sqrt{\frac{280\nu x}{13U_{\infty}}}$$

develop the expression for local drag coefficient  $C_{fx}$  over the distance  $x = L$  from the leading edge of the plate. (7 Marks)

- (b) A model test is to be conducted in a water tunnel using a 1:20 model of a submarine which is used to travel at a speed of 12 km/h deep under the sea. The water temperature in the tunnel is so maintained that its kinematic viscosity is half as that of the sea water. At what speed the model test is to be conducted. (7 Marks)
20. (a) With a neat sketch explain the different regions of the boundary layer along a long thin flat plate. (7 Marks)
- (b) Using Buckingham's pi theorem show that the velocity through a circular orifice is given by

$$\sqrt{2gH} \phi \left[ \frac{D}{H}, \frac{\mu}{\rho V H} \right]$$

where  $H$  is the head causing flow,  $D$  is the diameter of the orifice,  $\mu$  is the coefficient of viscosity,  $\rho$  is the mass density and  $g$  is the acceleration due to gravity. (7 Marks)



## ASSESSMENT PATTERN

Bloom's taxonomy	Continuous Assessment Tests		End Semester Examination (Marks)
	Test 1 (Marks)	Test 11 (Marks)	
Remember	25	25	25
Understand	15	15	15
Apply	30	25	30
Analyze	10	10	10
Evaluate	10	15	10
Create	10	10	10

### Mark distribution

Total Marks	CIE marks	ESE marks	ESE duration
150	50	100	3 Hours

### Continuous Internal Evaluation (CIE) Pattern:

Attendance	10 marks
Regular class work/tutorials/assignments	15 marks
Continuous Assessment Test (Minimum 2 numbers)	25 marks

**End semester pattern:-** There will be two parts; Part A and Part B. Part A contain 10 questions with 2 questions from each module, having 3 marks for each question. Students should answer all questions. Part B contains 2 questions from each module of which student should answer any one. Each question can have maximum 2 sub-divisions and carry 14 marks.

## COURSE LEVEL ASSESSMENT QUESTIONS

### Part -A

**Course Outcome 1 (CO1):** Understand the basic chemical bonds, crystal structures (BCC, FCC, and HCP), and their relationship with the properties.

1. What are the attributes of atomic and crystalline structures into the stress - strain curve?
2. Explain the significance of long range and short range order of atomic arrangement on mechanical strength.
3. What is the difference between an allotrope and a polymorphism?
4. Draw the (112) and (111) planes in simple cubic cell.

**Course Outcome 2 (CO2):** Analyze the microstructure of metallic materials using phase diagrams and modify the microstructure and properties using different heat treatments.

1. What is the driving force for recrystallisation and grain growth of metallic crystals?
2. What is the driving force for the formation of spheroidite.
3. What is tempered martensite?
4. Why 100 % pure metals are weak in strength?

#### **Part -B**

**Course Outcome 3 (CO3):** How to quantify mechanical integrity and failure in materials

1. A small hole is drilled through a steel plate ahead of a crack, whether it can stop the crack's progress until repairs can be made. Explain in detail and derive the equation for the principle.
2. Draw and explain S-N curves for ferrous and non-ferrous metals. Explain different methods to improve fatigue resistance.
3. Explain different stages of creep; Give an application of creep phenomenon. What is superplasticity?

**Course Outcome 4 (CO4):** Apply the basic principles of ferrous and non-ferrous metallurgy for selecting materials for specific applications.

1. What are the classification, compositions and applications of high speed steel? identify 18:4:1
2. Describe the composition, properties, and use of Bronze and Gun metal.
3. Explain the importance of all the non-ferrous alloys in automotive applications. Elaborate on the composition, properties and typical applications of any five non-ferrous alloys.

**Course Outcome 5 (CO5):** Define and differentiate engineering materials on the basis of structure and properties for engineering applications.

1. Carbon is allowed to diffuse through a steel plate 15 mm thick. The concentrations of carbon at the two faces are 0.65 and 0.30kgC/m<sup>3</sup>Fe, which are maintained constant. If the pre-exponential and activation energy are  $6.2 \times 10^{-7} \text{m}^2/\text{s}$  and 80,000 J/mol, respectively, compute the temperature at which the diffusion flux is  $1.43 \times 10^{-9} \text{kg}/\text{m}^2\text{-s}$ .
2. Explain the fundamental effects of alloying elements in steel on polymorphic transformation temperatures, grain growth, eutectoid point, retardation of the transformation rates, formation and stability of carbides.
3. Describe the kind of fracture which may occur as a result of a loose fitting key on a shaft.

### **SYLLABUS**

#### **MODULE - 1**

Earlier and present development of atomic structure - Primary bonds: - characteristics of covalent, ionic and metallic bond - properties based on atomic bonding: - Secondary bonds: - classification, application. (*Brief review only*).

Crystallography: - SC, BCC, FCC, HCP structures, APF - theoretical density simple problems - Miller Indices: - crystal plane and direction - Modes of plastic deformation: - Slip and twinning -Schmid's law - Crystallization: Effects of grain size, Hall - Petch theory, simple problems.

## **MODULE - II**

Classification of crystal imperfections - forest of dislocation, role of surface defects on crack initiation- Burgers vector –Frank Read source - Correlation of dislocation density with strength and nano concept - high and low angle grain boundaries– driving force for grain growth and applications - Polishing and etching - X – ray diffraction, simple problems –SEM and TEM - Diffusion in solids, fick's laws, mechanisms, applications of diffusion in mechanical engineering, simple problems.

## **MODULE - III**

Phase diagrams: - need of alloying - classification of alloys - Hume Rothery's rule - equilibrium diagram of common types of binary systems: five types - Coring - lever rule and Gibb's phase rule - Reactions- Detailed discussion on Iron-Carbon equilibrium diagram with microstructure and properties -Heat treatment: - TTT, CCT diagram, applications - Tempering- Hardenability, Jominy end quench test, applications- Surface hardening methods.

## **MODULE - IV**

Strengthening mechanisms - cold and hot working - alloy steels: how alloying elements affecting properties of steel - nickel steels - chromium steels - high speed steels -cast irons - principal non ferrous alloys.

## **MODULE - V**

Fatigue: - creep -DBTT - super plasticity - need, properties and applications of composites, super alloy, intermetallics, maraging steel, Titanium - Ceramics:- structures, applications.

### **Text Books**

1. Callister William. D., Material Science and Engineering, John Wiley, 2014
2. Higgins R.A. - Engineering Metallurgy part - I – ELBS,1998

### **Reference**

1. Avner H Sidney, Introduction to Physical Metallurgy, Tata McGraw Hill,2009
2. Anderson J.C. *et.al.*, Material Science for Engineers, Chapman and Hall,1990
3. Clark and Varney, Physical metallurgy for Engineers, Van Nostrand,1964
4. Dieter George E, Mechanical Metallurgy, Tata McGraw Hill, 1976
5. Raghavan V, Material Science and Engineering, Prentice Hall,2004
6. Reed Hill E. Robert, Physical metallurgy principles, 4<sup>th</sup> edition, Cengage Learning,2009
7. Myers Marc and Krishna Kumar Chawla, Mechanical behavior of materials, Cambridge University press,2008
8. Van Vlack -Elements of Material Science - Addison Wesley,1989
9. <https://nptel.ac.in/courses/113/106/113106032>

## MODEL QUESTION PAPER

### METALLURGY & MATERIAL SCIENCE - MET 205

Max. Marks : 100

Duration : 3 Hours

#### Part – A

Answer all questions.

Answer all questions, each question carries 3 marks

1. What is a slip system? Describe the slip systems in FCC, BCC and HCP metals
2. NASA's *Parker Solar Probe* will be the first-ever mission to "touch" the Sun. The spacecraft, about the size of a small car, will travel directly into the Sun's atmosphere about 4 million miles from the earth surface. Postulate the coolant used in the parker solar probe with chemical bonds.
3. What is the driving force for grain growth during heat treatment
4. What are the roles of surface imperfections on crack initiation
5. Explain the difference between hardness and hardenability.
6. What is tempered martensite? Explain its structure with sketch.
7. Postulate, why cast irons are brittle?
8. How are properties of aluminum affected by the inclusion of (a) copper and (b) silicon as alloying elements?
9. What is the grain size preferred for creep applications? Why. Explain thermal fatigue?
10. Explain fracture toughness and its attributes into a screw jack?

#### PART -B

Answer one full question from each module.

#### MODULE – 1

11. **a.** Calculate the APF of SC, BCC and FCC (7 marks).  
**b.** What is slip system and explain why FCC materials exhibit ductility and BCC and HCP exhibit brittle nature with details of slip systems (7 marks).

#### OR

12. Explain the effect of: (i) Grain size; (ii) Grain size distribution and (iii) Grain orientation (iv) Grain shape on strength and creep resistance with neat sketches. Attributes of Hall-Petch equation and grain boundaries (14 marks).

#### MODULE – 2

13. **a.** Describe step by step procedure for metallographic specimen preparation? Name different types etchants used for specific metals and methods to determine grain size (7 marks).

b. Carbon is allowed to diffuse through a steel plate 15 mm thick. The concentrations of carbon at the two faces are 0.65 and 0.30 kgC/m<sup>3</sup>Fe, which are maintained constant. If the pre-exponential and activation energy are  $6.2 \times 10^{-7} \text{m}^2/\text{s}$  and 80,000 J/mol, respectively, compute the temperature at which the diffusion flux is  $1.43 \times 10^{-9} \text{kg/m}^2\text{-s}$  (7 marks).

**OR**

14. a. Explain the fundamental differences of SEM and TEM with neat sketches (7 marks).

b. A beam of X-rays wavelength  $1.54 \text{Å}$  is incident on a crystal at a glancing angle of  $8^\circ 35'$  when the first order Bragg's reflection occurs calculate the glancing angle for third order reflection (7 marks).

### **MODULE – 3**

15. Postulate with neat sketches, why 100% pure metals are weaker? What are the primary functions of alloying? Explain the fundamental rules governing the alloying with neat sketches and how is it accomplished in substitution and interstitial solid solutions (14 marks).

**OR**

16. Draw the isothermal transformation diagram of eutectoid steel and then sketch and label (1) A time temperature path that will produce 100% pure coarse and fine pearlite (2) A time temperature path that will produce 50% martensite and 50% bainite (3) A time temperature path that will produce 100% martensite (4) A time temperature path that will produce 100% bainite (14 marks).

### **MODULE – 4**

17. Explain the effect of, polymorphic transformation temperature, formation and stability of carbides, grain growth, displacement of the eutectoid point, retardation of the transformation rates, improvement of corrosion resistance on adding alloy elements to steel (14 marks).

**OR**

18. Give the composition, microstructure, properties and applications of (i) Gray iron and SG iron. (ii) White iron and Gray iron. (iii) Malleable iron and Gray iron. (iv) Gray iron and Mottled iron, (v) SG iron and Vermicullar Graphite Iron (14 marks).

### **MODULE – 5**

19. a. A small hole is drilled through a steel plate ahead of a crack, whether it can stop the crack's progress until repairs can be made or not? Explain in detail and derive the equation (7 marks).

b. What is ductile to brittle transition in steel DBTT? What are the factors affecting ductile to brittle transition? Narrate with neat sketch (7 marks).

**OR**

20. Classify ceramics with radius ratio with neat sketches. Explain with an example for each of the AX, AmXp, AmBmXp type structures in ceramics with neat sketch (14 marks).

**COURSE CONTENT AND LECTURE SCHEDULES.**

<b>Module</b>	<b>TOPIC</b>	<b>No. of hours</b>	<b>Course outcomes</b>
1.1	Earlier and present development of atomic structure; attributes of ionization energy and conductivity, electronegativity; correlation of atomic radius to strength; electron configurations; - Primary bonds: - characteristics of covalent, ionic and metallic bond: attributes of bond energy, cohesive force, density, directional and non-directional - properties based on atomic bonding:- attributes of deeper energy well and shallow energy well to melting temperature, coefficient of thermal expansion - attributes of modulus of elasticity in metal cutting process -Secondary bonds:- classification- hydrogen bond and anomalous behavior of ice float on water, application- specific heat, applications. (Brief review only).	2	CO1
1.2	Crystallography:- Crystal, space lattice, unit cell- SC, BCC, FCC, atomic packing factor and HCP structures - short and long range order - effects of crystalline and amorphous structure on mechanical properties.	2	CO1 CO2
1.3	Coordination number and radius ratio; theoretical density; simple problems - Polymorphism and allotropy.	1	
1.4	Miller Indices: - crystal plane and direction - Attributes of miller indices for slip system, brittleness of BCC, HCP and ductility of FCC - Modes of plastic deformation: - Slip and twinning.	1	CO5
1.5	Schmid's law, equation, critical resolved shear stress, correlation of slip system with plastic deformation in metals and applications.	1	
1.6	Mechanism of crystallization: Homogeneous and heterogeneous nuclei formation, under cooling, dendritic growth, grain boundary irregularity - Effects of grain size, grain size distribution, grain shape, grain orientation on dislocation/strength and creep resistance - Hall - Petch theory, simple problems.	2	CO2
2.1	Classification of crystal imperfections: - types of point and dislocations.	1	CO2
2.2	Effect of point defects on mechanical properties - forest of dislocation, role of surface defects on crack initiation - Burgers vector.	1	
2.3	Dislocation source, significance of Frank-Read source in metals deformation - Correlation of dislocation density with strength and nano concept, applications.	3	CO2
2.4	Significance high and low angle grain boundaries on dislocation – driving force for grain growth and applications during heat treatment.		
2.5	Polishing and etching to determine the microstructure and grain size- Fundamentals and crystal structure determination by X – ray diffraction, simple problems –SEM and TEM.	2	CO2 CO5
2.6	Diffusion in solids, fick's laws, mechanisms, applications of diffusion in mechanical engineering, simple problems.	1	



3.1	Phase diagrams: - Limitations of pure metals and need of alloying - classification of alloys, solid solutions, Hume Rothery's rule - equilibrium diagram of common types of binary systems: five types.	2	CO2 CO5
3.2	Coring - lever rule and Gibb's phase rule - Reactions: - monotectic, eutectic, eutectoid, peritectic, peritectoid.	1	
3.3	Detailed discussion on Iron-Carbon equilibrium diagram with microstructure and properties changes in austenite, ledeburite, ferrite, cementite, special features of martensite transformation, bainite, spheroidite etc.	3	CO2 CO5
3.4	Heat treatment: - Definition and necessity – TTT for a eutectoid iron-carbon alloy, CCT diagram, applications - annealing, normalizing, hardening, spheroidizing.		
3.5	Tempering:- austempering, martempering and ausforming - Comparative study on ductility and strength with structure of pearlite, bainite, spherodite, martensite, tempered martensite and ausforming.	1	CO2
3.6	Hardenability, Jominy end quench test, applications- Surface hardening methods:- no change in surface composition methods :- Flame, induction, laser and electron beam hardening processes- change in surface composition methods :carburizing and Nitriding; applications.	2	CO2
4.1	Cold working: Detailed discussion on strain hardening; recovery; recrystallization, effect of stored energy; re- crystallization temperature - hot working, Bauschinger effect and attributes in metal forming.	1	
4.2	Alloy steels:- Effects of alloying elements on steel: dislocation movement, polymorphic transformation temperature, alpha and beta stabilizers, formation and stability of carbides, grain growth, displacement of the eutectoid point, retardation of the transformation rates, improvement in corrosion resistance, mechanical properties	1	CO4
4.3	Nickel steels, Chromium steels etc. – change of steel properties by adding alloying elements: - Molybdenum, Nickel, Chromium, Vanadium, Tungsten, Cobalt, Silicon, Copper and Lead - High speed steels - Cast irons: Classifications; grey, white, malleable and spheroidal graphite cast iron etc, composition, microstructure, properties and applications - Principal Non ferrous Alloys: - Aluminum, Copper, Magnesium, Nickel, study of composition, properties, applications, reference shall be made to the phase diagrams whenever necessary.( Topic 4.3 may be considered as a assignment).	4	CO4 CO5
4.4	Fatigue: - Stress cycles – Primary and secondary stress raisers - Characteristics of fatigue failure, fatigue tests, S-N curve.	1	CO3
4.5	Factors affecting fatigue strength: stress concentration, size effect, surface roughness, change in surface properties, surface residual stress - Ways to improve fatigue life – effect of temperature on fatigue, thermal fatigue and its applications in metal cutting.	2	

5.1	Fracture: – Brittle and ductile fracture – Griffith theory of brittle fracture – Stress concentration, stress raiser – Effect of plastic deformation on crack propagation - transgranular, intergranular fracture - Effect of impact loading on ductile material and its application in forging, applications - Mechanism of fatigue failure.	2	CO3
5.2	Structural features of fatigue: - crack initiation, growth, propagation - Fracture toughness (definition only), applications - Ductile to brittle transition temperature (DBTT) in steels and structural changes during DBTT, applications.	1	
5.3	Creep: - Creep curves – creep tests - Structural change:- deformation by slip, sub-grain formation, grain boundary sliding - Mechanism of creep deformation - threshold for creep, prevention against creep - Super plasticity: need and applications	2	CO3
5.4	Composites: - Need of development of composites; fiber phase; matrix phase; only need and characteristics of PMC, MMC, and CMC.	2	CO3 CO5
5.5	Modern engineering materials: - only fundamentals, need, properties and applications of, intermetallics, maraging steel, super alloys, Titanium-Ceramics:-coordination number and radius ratios- AX, A <sub>m</sub> X <sub>p</sub> , A <sub>m</sub> B <sub>m</sub> X <sub>p</sub> type structures – applications.	3	

COURSE CODE	COURSE NAME	CATEGORY	L	T	P	CREDITS
22EST305	DESIGN AND ENGINEERING	ES	2	0	0	2

**Preamble:**

The purpose of this course is to

- i) introduce the undergraduate engineering students the fundamental principles of design engineering,
- ii) make them understand the steps involved in the design process and
- iii) familiarize them with the basic tools used and approaches in design.

Students are expected to apply design thinking in learning as well as while practicing engineering, which is very important and relevant for today. Case studies from various practical situations will help the students realize that design is not only concerned about the function but also many other factors like customer requirements, economics, reliability, etc. along with a variety of life cycle issues.

The course will help students to consider aesthetics, ergonomics and sustainability factors in designs and also to practice professional ethics while designing.

**Prerequisite:**

**Nil.** The course will be generic to all engineering disciplines and will not require specialized preparation or prerequisites in any of the individual engineering disciplines.

**Course Outcomes:**

After the completion of the course the student will be able to

<b>CO 1</b>	Explain the different concepts and principles involved in design engineering.
<b>CO 2</b>	Apply design thinking while learning and practicing engineering.
<b>CO 3</b>	Develop innovative, reliable, sustainable and economically viable designs incorporating knowledge in engineering.

**Mapping of course outcomes with program outcomes**

	PO 1	PO 2	PO 3	PO 4	PO 5	PO 6	PO 7	PO 8	PO 9	PO 10	PO 11	PO 12
<b>CO 1</b>	2	1					1			1		
<b>CO 2</b>		2				1		1				2
<b>CO 3</b>			2			1	1		2	2		1

## Assessment Pattern

### Continuous Internal Evaluation (CIE) Pattern:

Attendance : 10 marks

Continuous Assessment Test (2 numbers) : 25 marks

Assignment/Quiz/Course project : 15 marks

**End Semester Examination (ESE) Pattern:** There will be two parts; Part A and Part B.

Part A : 30 marks

part B : 70 marks

Part A contains 10 questions with 2 questions from each module, having 3 marks for each question. Students should answer all questions.

Part B contains 2 case study questions from each module of which student should answer any one. Each question carry 14 marks and can have maximum 2 sub questions.

### Mark distribution

Total Marks	CIE	ESE	ESE Duration
150	50	100	3 hours

Bloom's Category	Continuous Assessment Tests		End Semester Examination
	1	2	
Remember	5	5	10
Understand	10	10	20
Apply	35	35	70
Analyse	-	-	-
Evaluate	-	-	-
Create	-	-	-

## **Course Level Assessment Questions**

### **Course Outcome 1 (CO1): Appreciate the different concepts and principles involved in design engineering.**

1. State how engineering design is different from other kinds of design
2. List the different stages in a design process.
3. Describe design thinking.
4. State the function of prototyping and proofing in engineering design.
5. Write notes on the following concepts in connection with design engineering 1) Modular Design, 2) Life Cycle Design, 3) Value Engineering, 4) Concurrent Engineering, and 5) Reverse Engineering
6. State design rights.

### **Course Outcome 2 (CO2) Apply design thinking while learning and practicing engineering.**

1. Construct the iterative process for design thinking in developing simple products like a pen, umbrella, bag, etc.
2. Show with an example how divergent-convergent thinking helps in generating alternative designs and then how to narrow down to the best design.
3. Describe how a problem-based learning helps in creating better design engineering solutions.
4. Discuss as an engineer, how ethics play a decisive role in your designs

### **Course Outcome 3 (CO3): Develop innovative, reliable, sustainable and economically viable designs incorporating different segments of knowledge in engineering.**

1. Illustrate the development of any simple product by passing through the different stages of design process
2. Show the graphical design communication with the help of detailed 2D or 3D drawings for any simple product.
3. Describe how to develop new designs for simple products through bio-mimicry.

**Model Question paper**

Page 1 of 2

Reg No.: \_\_\_\_\_ Name: \_\_\_\_\_

**THIRD/FOURTH SEMESTER B.TECH DEGREE EXAMINATION**

**Course Code: EST 200**

**Course Name: DESIGN AND ENGINEERING**

**Max. Marks: 100 Duration: 3 Hours**

**PART A**

**Answer all questions, each question carries 3 marks**

**Use only hand sketches**

- (1) Write about the basic design process.
- (2) Describe how to finalize the design objectives.
- (3) State the role of divergent-convergent questioning in design thinking.
- (4) Discuss how to perform design thinking in a team managing the conflicts.
- (5) Show how engineering sketches and drawings convey designs.
- (6) Explain the role of mathematics and physics in design engineering process.
- (7) Distinguish between project-based learning and problem-based learning in design engineering.
- (8) Describe how concepts like value engineering, concurrent engineering and reverse engineering influence engineering designs?
- (9) Show how designs are varied based on the aspects of production methods, life span, reliability and environment?
- (10) Explain how economics influence the engineering designs?

**(10x3 marks =30 marks)**

**Part B**

**Answer any ONE question from each module. Each question carry 14 marks**

**Module 1**

- (11) Show the designing of a wrist watch going through the various stages of the design process. Use hand sketches to illustrate the processes.  
or
- (12) Find the customer requirements for designing a new car showroom. Show how the design objectives were finalized considering the design constraints?

### **Module 2**

(13) Illustrate the design thinking approach for designing a bag for college students within a limited budget. Describe each stage of the process and the iterative procedure involved. Use hand sketches to support your arguments.

**or**

(14) Construct a number of possible designs and then refine them to narrow down to the best design for a drug trolley used in hospitals. Show how the divergent-convergent thinking helps in the process. Provide your rationale for each step by using hand sketches only.

### **Module 3**

(15) Graphically communicate the design of a thermo flask used to keep hot coffee. Draw the detailed 2D drawings of the same with design detailing, material selection, scale drawings, dimensions, tolerances, etc. Use only hand sketches.

**or**

(16) Describe the role of mathematical modelling in design engineering. Show how mathematics and physics play a role in designing a lifting mechanism to raise 100 kg of weight to a floor at a height of 10 meters in a construction site.

### **Module 4**

(17) Show the development of a nature inspired design for a solar powered bus waiting shed beside a highway. Relate between natural and man-made designs. Use hand sketches to support your arguments.

**or**

(18) Show the design of a simple sofa and then depict how the design changes when considering 1) aesthetics and 2) ergonomics into consideration. Give hand sketches and explanations to justify the changes in designs.

### **Module 5**

(19) Examine the changes in the design of a foot wear with constraints of 1) production methods, 2) life span requirement, 3) reliability issues and 4) environmental factors. Use hand sketches and give proper rationalization for the changes in design.

**or**

(20) Describe how to estimate the cost of a particular design using ANY of the following: i) a website, ii) the layout of a plant, iii) the elevation of a building, iv) an electrical or electronic system or device and v) a car.

Show how economics will influence the engineering designs. Use hand sketches to support your arguments.

**(5x14 marks =70 marks)**

## Syllabus

### Module 1

Design Process:- Introduction to Design and Engineering Design, Defining a Design Process:-Detailing Customer Requirements, Setting Design Objectives, Identifying Constraints, Establishing Functions, Generating Design Alternatives and Choosing a Design.

### Module 2

Design Thinking Approach:-Introduction to Design Thinking, Iterative Design Thinking Process Stages: Empathize, Define, Ideate, Prototype and Test. Design Thinking as Divergent-Convergent Questioning. Design Thinking in a Team Environment.

### Module 3

Design Communication (Languages of Engineering Design):-Communicating Designs Graphically, Communicating Designs Orally and in Writing. Mathematical Modeling In Design, Prototyping and Proofing the Design.

### Module 4

Design Engineering Concepts:-Project-based Learning and Problem-based Learning in Design.Modular Design and Life Cycle Design Approaches. Application of Biomimicry,Aesthetics and Ergonomics in Design. Value Engineering, Concurrent Engineering, and Reverse Engineering in Design.

### Module 5

Expediency, Economics and Environment in Design Engineering:-Design for Production, Use, and Sustainability. Engineering Economics in Design. Design Rights. Ethics in Design

### Text Books

- 1) YousefHaik, SangarappillaiSivaloganathan, Tamer M. Shahin, Engineering Design Process, Cengage Learning 2003, Third Edition, ISBN-10: 9781305253285,
- 2) Voland, G., Engineering by Design, Pearson India 2014, Second Edition, ISBN 9332535051

### Reference Books

- 1.Philip Kosky, Robert Balmer, William Keat, George Wise, Exploring Engineering, Fourth Edition: An Introduction to Engineering and Design, Academic Press 2015, 4th Edition, ISBN: 9780128012420.
2. Clive L. Dym, Engineering Design: A Project-Based Introduction, John Wiley & Sons, New York 2009, Fourth Edition, ISBN: 978-1-118-32458-5
3. Nigel Cross, Design Thinking: Understanding How Designers Think and Work, Berg Publishers 2011, First Edition, ISBN: 978-1847886361
4. Pahl, G., Beitz, W., Feldhusen, J., Grote, K.-H., Engineering Design: A Systematic Approach, Springer 2007, Third Edition, ISBN 978-1-84628-319-2



## Course Contents and Lecture Schedule

No	Topic	No. of Lectures
1	<b><u>Module 1: Design Process</u></b>	
1.1	Introduction to Design and Engineering Design. <i>What does it mean to design something? How Is engineering design different from other kinds of design? Where and when do engineers design? What are the basic vocabulary in engineering design? How to learn and do engineering design.</i>	1
1.2	<i>Defining a Design Process-: Detailing Customer Requirements.</i> <i>How to do engineering design? Illustrate the process with an example. How to identify the customer requirements of design?</i>	1
1.3	<i>Defining a Design Process-: Setting Design Objectives, Identifying Constraints, Establishing Functions.</i> <i>How to finalize the design objectives? How to identify the design constraints? How to express the functions a design in engineering terms?</i>	1
1.4	<i>Defining a Design Process-: Generating Design Alternatives and Choosing a Design.</i> <i>How to generate or create feasible design alternatives? How to identify the "best possible design"?</i>	1
1.5	Case Studies:- Stages of Design Process. <i>Conduct exercises for designing simple products going through the different stages of design process.</i>	1
2	<b><u>Module 2: Design Thinking Approach</u></b>	
2.1	Introduction to Design Thinking <i>How does the design thinking approach help engineers in creating innovative and efficient designs?</i>	1
2.2	Iterative Design Thinking Process Stages: Empathize, Define, Ideate, Prototype and Test. <i>How can the engineers arrive at better designs utilizing the iterative design thinking process (in which knowledge acquired in the later stages can be applied back to the earlier stages)?</i>	1
2.3	Design Thinking as Divergent-Convergent Questioning. <i>Describe how to create a number of possible designs and then how to refine and narrow down to the 'best design'.</i>	1
2.4	Design Thinking in a Team Environment. <i>How to perform design thinking as a team managing the conflicts ?</i>	1
2.5	Case Studies: Design Thinking Approach. <i>Conduct exercises using the design thinking approach for</i>	1

	<i>designing any simple products within a limited time and budget</i>	
<b>3</b>	<b><u>Module 3: Design Communication (Languages of Engineering Design)</u></b>	
3.1	Communicating Designs Graphically. <i>How do engineering sketches and drawings convey designs?</i>	1
3.2	Communicating Designs Orally and in Writing. <i>How can a design be communicated through oral presentation or technical reports efficiently?</i>	1
<b>First Series Examination</b>		
3.3	Mathematical Modelling in Design. <i>How do mathematics and physics become a part of the design process?</i>	1
3.4	Prototyping and Proofing the Design. <i>How to predict whether the design will function well or not?</i>	1
3.5	Case Studies: Communicating Designs Graphically. <i>Conduct exercises for design communication through detailed 2D or 3D drawings of simple products with design detailing, material selection, scale drawings, dimensions, tolerances, etc.</i>	1
<b>4</b>	<b><u>Module 4: Design Engineering Concepts</u></b>	
4.1	Project-based Learning and Problem-based Learning in Design. <i>How engineering students can learn design engineering through projects?</i> <i>How students can take up problems to learn design engineering?</i>	1
4.2	Modular Design and Life Cycle Design Approaches. <i>What is modular approach in design engineering? How it helps?</i> <i>How the life cycle design approach influences design decisions?</i>	1
4.3	Application of Bio-mimicry, Aesthetics and Ergonomics in Design. <i>How do aesthetics and ergonomics change engineering designs?</i> <i>How do the intelligence in nature inspire engineering designs? What are the common examples of bio-mimicry in engineering?</i>	1
4.4	Value Engineering, Concurrent Engineering, and Reverse Engineering in Design. <i>How do concepts like value engineering , concurrent engineering and reverse engineering influence engineering designs?</i>	1
4.5	Case Studies: Bio-mimicry based Designs. <i>Conduct exercises to develop new designs for simple</i>	1

	<i>products using bio-mimicry and train students to bring out new nature inspired designs.</i>	
5	<b><u>Module 5: Expediency, Economics and Environment in Design Engineering</u></b>	
5.1	Design for Production, Use, and Sustainability. <i>How designs are finalized based on the aspects of production methods, life span, reliability and environment?</i>	1
5.2	Engineering Economics in Design. <i>How to estimate the cost of a particular design and how will economics influence the engineering designs?</i>	1
5.3	Design Rights. <i>What are design rights and how can an engineer put it into practice?</i>	1
5.4	Ethics in Design. <i>How do ethics play a decisive role in engineering design?</i>	1
5.5	Case Studies: Design for Production, Use, and Sustainability. <i>Conduct exercises using simple products to show how designs change with constraints of production methods, life span requirement, reliability issues and environmental factors.</i>	1
<b>Second Series Examination</b>		

COURSE CODE	COURSE NAME	CATEGORY	L	T	P	CREDITS
22HUT306	PROFESSIONAL ETHICS	HU	2	0	0	2

**Preamble:** To enable students to create awareness on ethics and human values.

**Prerequisite:** Nil

**Course Outcomes:** After the completion of the course the student will be able to

<b>CO 1</b>	Understand the core values that shape the ethical behaviour of a professional.
<b>CO 2</b>	Adopt a good character and follow an ethical life.
<b>CO 3</b>	Explain the role and responsibility in technological development by keeping personal ethics and legal ethics.
<b>CO 4</b>	Solve moral and ethical problems through exploration and assessment by established experiments.
<b>CO 5</b>	Apply the knowledge of human values and social values to contemporary ethical values and global issues.

#### Mapping of course outcomes with program outcomes

	PO 1	PO 2	PO 3	PO 4	PO 5	PO 6	PO 7	PO 8	PO 9	PO1 0	PO1 1	PO1 2
<b>CO 1</b>								2			2	
<b>CO 2</b>								2			2	
<b>CO 3</b>								3			2	
<b>CO 4</b>								3			2	
<b>CO 5</b>								3			2	

#### Assessment Pattern

Bloom's category	Continuous Assessment Tests		End Semester Exam
	1	2	
Remember	15	15	30
Understood	20	20	40
Apply	15	15	30

#### Mark distribution

Total Marks	CIE	ESE	ESE Duration
150	50	100	3 hours

### **Continuous Internal Evaluation Pattern:**

Attendance	: 10 marks
Continuous Assessment Tests (2 Nos)	: 25 marks
Assignments/Quiz	: 15 marks

**End Semester Examination Pattern:** There will be two parts; Part A and Part B. Part A contains 10 questions with 2 questions from each module, having 3 marks for each question. Students should answer all questions. Part B contains 2 questions from each module of which student should answer any one. Each question can have maximum 2 sub-divisions and carry 14 marks.

### **Course Level Assessment Questions**

#### **Course Outcome 1 (CO1):**

1. Define integrity and point out ethical values.
2. Describe the qualities required to live a peaceful life.
3. Explain the role of engineers in modern society.

#### **Course Outcome 2 (CO2)**

1. Derive the codes of ethics.
2. Differentiate consensus and controversy.
3. Discuss in detail about character and confidence.

#### **Course Outcome 3(CO3):**

1. Explain the role of professional's ethics in technological development.
2. Distinguish between self interest and conflicts of interest.
3. Review on industrial standards and legal ethics.

#### **Course Outcome 4 (CO4):**

1. Illustrate the role of engineers as experimenters.
2. Interpret the terms safety and risk.
3. Show how the occupational crimes are resolved by keeping the rights of employees.

#### **Course Outcome 5 (CO5):**

1. Exemplify the engineers as managers.
2. Investigate the causes and effects of acid rain with a case study.
3. Explore the need of environmental ethics in technological development.

**Model Question paper**

QP CODE:

Reg No: \_\_\_\_\_

PAGES:3

Name : \_\_\_\_\_

**B.TECH DEGREE EXAMINATION, MONTH & YEAR**

**Course Code: HUT 200**

**Course Name: PROFESSIONAL ETHICS**

**Max. Marks: 100**

**Duration: 3 Hours**

**(2019-Scheme)**

**PART A**

**(Answer all questions, each question carries 3 marks)**

1. Define empathy and honesty.
2. Briefly explain about morals, values and ethics.
3. Interpret the two forms of self-respect.
4. List out the models of professional roles.
5. Indicate the advantages of using standards.
6. Point out the conditions required to define a valid consent?
7. Identify the conflicts of interests with an example?
8. Recall confidentiality.
9. Conclude the features of biometric ethics.
10. Name any three professional societies and their role relevant to engineers.

(10x3 = 30 marks)

**PART B**

**(Answer one full question from each module, each question carries 14 marks)**

**MODULE I**

11. a) Classify the relationship between ethical values and law?

b) Compare between caring and sharing.

(10+4 = 14 marks)

**Or**

12. a) Exemplify a comprehensive review about integrity and respect for others.

**b)** Discuss about co-operation and commitment. (8+6 = 14 marks)

## **MODULE II**

**13.a)** Explain the three main levels of moral developments, devised by Kohlberg.

**b)** Differentiate moral codes and optimal codes. (10+4 = 14 marks)

**Or**

**14. a)** Extrapolate the duty ethics and right ethics.

**b)** Discuss in detail the three types of inquiries in engineering ethics (8+6 = 14 marks)

## **MODULE III**

**15.a)** Summarize the following features of morally responsible engineers.

**(i)** Moral autonomy

**(ii)** Accountability

**b)** Explain the rights of employees (8+6 = 14 marks)

**Or**

**16. a)** Explain the reasons for Chernobyl mishap ?

**b)** Describe the methods to improve collegiality and loyalty. (8+6 = 14 marks)

## **MODULE IV**

**17.a)** Execute collegiality with respect to commitment, respect and connectedness.

**b)** Identify conflicts of interests with an example. (8+6 = 14 marks)

**Or**

**18. a)** Explain in detail about professional rights and employee rights.

**b)** Exemplify engineers as managers.

## **MODULE V**

**19.a)** Evaluate the technology transfer and appropriate technology.

**b)** Explain about computer and internet ethics. (8+6 = 14 marks)

**Or**

**20. a)** Investigate the causes and effects of acid rain with a case study.

**b)** Conclude the features of ecocentric and biocentric ethics. (8+6 = 14 marks)

## Syllabus

### **Module 1 – Human Values.**

Morals, values and Ethics – Integrity- Academic integrity-Work Ethics- Service Learning- Civic Virtue- Respect for others- Living peacefully- Caring and Sharing- Honestly- courage-Cooperation commitment- Empathy-Self Confidence -Social Expectations.

### **Module 2 - Engineering Ethics & Professionalism.**

Senses of Engineering Ethics - Variety of moral issues- Types of inquiry- Moral dilemmas –Moral Autonomy – Kohlberg’s theory- Gilligan’s theory- Consensus and Controversy-Profession and Professionalism- Models of professional roles-Theories about right action –Self interest-Customs and Religion- Uses of Ethical Theories.

### **Module 3- Engineering as social Experimentation.**

Engineering as Experimentation – Engineers as responsible Experimenters- Codes of Ethics- Plagiarism- A balanced outlook on law - Challenges case study- Bhopal gas tragedy.

### **Module 4- Responsibilities and Rights.**

Collegiality and loyalty – Managing conflict- Respect for authority- Collective bargaining- Confidentiality- Role of confidentiality in moral integrity-Conflicts of interest- Occupational crime- Professional rights- Employee right- IPR Discrimination.

### **Module 5- Global Ethical Issues.**

Multinational Corporations- Environmental Ethics- Business Ethics- Computer Ethics -Role in Technological Development-Engineers as Managers- Consulting Engineers- Engineers as Expert witnesses and advisors-Moral leadership.

### **Text Book**

1. M Govindarajan, S Natarajan and V S Senthil Kumar, Engineering Ethics, PHI Learning Private Ltd, New Delhi,2012.
2. R S Naagarazan, A text book on professional ethics and human values, New age international (P) limited ,New Delhi,2006.

### **Reference Books**

1. Mike W Martin and Roland Schinzinger, Ethics in Engineering,4<sup>th</sup> edition, Tata McGraw Hill Publishing Company Pvt Ltd, New Delhi,2014.
2. Charles D Fleddermann, Engineering Ethics, Pearson Education/ Prentice Hall of India, New Jersey,2004.
3. Charles E Harris, Michael S Protchard and Michael J Rabins, Engineering Ethics- Concepts and cases, Wadsworth Thompson Learning, United states,2005.
4. <http://www.slideword.org/slidestag.aspx/human-values-and-Professional-ethics>.



### Course Contents and Lecture Schedule

SL.No	Topic	No. of Lectures
<b>1</b>	<b>Module 1 – Human Values.</b>	
1.1	Morals, values and Ethics, Integrity, Academic Integrity, Work Ethics	1
1.2	Service Learning, Civic Virtue, Respect for others, Living peacefully	1
1.3	Caring and Sharing, Honesty, Courage, Co-operation commitment	2
1.4	Empathy, Self Confidence, Social Expectations	1
<b>2</b>	<b>Module 2- Engineering Ethics &amp; Professionalism.</b>	
2.1	Senses of Engineering Ethics, Variety of moral issues, Types of inquiry	1
2.2	Moral dilemmas, Moral Autonomy, Kohlberg's theory	1
2.3	Gilligan's theory, Consensus and Controversy, Profession & Professionalism, Models of professional roles, Theories about right action	2
2.4	Self interest-Customs and Religion, Uses of Ethical Theories	1
<b>3</b>	<b>Module 3- Engineering as social Experimentation.</b>	
3.1	Engineering as Experimentation, Engineers as responsible Experimenters	1
3.2	Codes of Ethics, Plagiarism, A balanced outlook on law	2
3.3	Challenger case study, Bhopal gas tragedy	2
<b>4</b>	<b>Module 4- Responsibilities and Rights.</b>	
4.1	Collegiality and loyalty, Managing conflict, Respect for authority	1
4.2	Collective bargaining, Confidentiality, Role of confidentiality in moral integrity, Conflicts of interest	2
4.3	Occupational crime, Professional rights, Employee right, IPR Discrimination	2
<b>5</b>	<b>Module 5- Global Ethical Issues.</b>	
5.1	Multinational Corporations, Environmental Ethics, Business Ethics, Computer Ethics	2
5.2	Role in Technological Development, Moral leadership	1
5.3	Engineers as Managers, Consulting Engineers, Engineers as Expert witnesses and advisors	2

COURSE CODE	COURSE NAME	CATEGORY	L	T	P	CREDITS
22MNC307	SUSTAINABLE ENGINEERING	ES	2	0	0	--

**Preamble:** Objective of this course is to inculcate in students an awareness of environmental issues and the global initiatives towards attaining sustainability. The student should realize the potential of technology in bringing in sustainable practices.

**Prerequisite:** NIL

**Course Outcomes:** After the completion of the course the student will be able to

<b>CO 1</b>	Understand the relevance and the concept of sustainability and the global initiatives in this direction
<b>CO 2</b>	Explain the different types of environmental pollution problems and their sustainable solutions
<b>CO 3</b>	Discuss the environmental regulations and standards
<b>CO 4</b>	Outline the concepts related to conventional and non-conventional energy
<b>CO 5</b>	Demonstrate the broad perspective of sustainable practices by utilizing engineering knowledge and principles

#### Mapping of course outcomes with program outcomes

	PO 1	PO 2	PO 3	PO 4	PO 5	PO 6	PO 7	PO 8	PO 9	PO 10	PO 11	PO 12
<b>CO 1</b>						2	3					2
<b>CO 2</b>						2	3					2
<b>CO 3</b>						2	3					2
<b>CO 4</b>						2	3					2
<b>CO 5</b>						2	3					2

#### Assessment Pattern

#### Mark distribution

Bloom's Category	Continuous Assessment Tests		End Semester Examination
	1	2	
Remember	20	20	40
Understand	20	20	40
Apply	10	10	20
Analyse			
Evaluate			
Create			

#### Continuous Internal Evaluation Pattern:

Attendance : 10 marks  
 Continuous Assessment Test (2 numbers) : 25 marks  
 Assignment/Quiz/Course project : 15 marks

**End Semester Examination Pattern:** There will be two parts; Part A and Part B. Part A contain 10 questions with 2 questions from each module, having 3 marks for each question. Students should answer all questions. Part B contains 2 questions from each module of which student should answer any one. Each question can have maximum 2 sub-divisions and carry 14 marks.

Total Marks	CIE	ESE	ESE Duration
150	50	100	3 hours

### Course Level Assessment Questions

**Course Outcome 1 (CO1):** Understand the relevance and the concept of sustainability and the global initiatives in this direction

1. Explain with an example a technology that has contributed positively to sustainable development.
2. Write a note on Millennium Development Goals.

**Course Outcome 2 (CO2):** Explain the different types of environmental pollution problems and their sustainable solutions

1. Explain the 3R concept in solid waste management?
2. Write a note on any one environmental pollution problem and suggest a sustainable solution.
3. In the absence of green house effect the surface temperature of earth would not have been suitable for survival of life on earth. Comment on this statement.

**Course Outcome 3(CO3):** Discuss the environmental regulations and standards

1. Illustrate Life Cycle Analysis with an example of your choice.
2. “Nature is the most successful designer and the most brilliant engineer that has ever evolved”. Discuss.

**Course Outcome 4 (CO4):** Outline the concepts related to conventional and non-conventional energy

1. Suggest a sustainable system to generate hot water in a residential building in tropical climate.
2. Enumerate the impacts of biomass energy on the environment.

**Course Outcome 5 (CO5):** Demonstrate the broad perspective of sustainable practices by utilizing engineering knowledge and principles

1. Suggest suitable measures to make the conveyance facilities used by your institution sustainable.

### Model Question paper

#### Part A

**(Answer all questions. Each question carries 3 marks each)**

1. Define sustainable development.
2. Write a short note on Millennium Development Goals.
3. Describe carbon credit.
4. Give an account of climate change and its effect on environment.
5. Describe biomimicry? Give two examples.
6. Explain the basic concept of Life Cycle Assessment.
7. Name three renewable energy sources.

8. Mention some of the disadvantages of wind energy.
9. Enlist some of the features of sustainable habitat.
10. Explain green engineering.

**Part B**

**(Answer one question from each module. Each question carries 14 marks)**

11. Discuss the evolution of the concept of sustainability. Comment on its relevance in the modern world.

OR

12. Explain Clean Development Mechanism.
13. Explain the common sources of water pollution and its harmful effects.

OR

14. Give an account of solid waste management in cities.
15. Explain the different steps involved in the conduct of Environmental Impact Assessment.

OR

16. Suggest some methods to create public awareness on environmental issues.
17. Comment on the statement, "Almost all energy that man uses comes from the Sun".

OR

18. Write notes on:
  - a. Land degradation due to water logging.
  - b. Over exploitation of water.

19. Discuss the elements related to sustainable urbanisation.

OR

20. Discuss any three methods by which you can increase energy efficiency in buildings.

## **Syllabus**

Sustainability- need and concept, technology and sustainable development-Natural resources and their pollution, Carbon credits, Zero waste concept. Life Cycle Analysis, Environmental Impact Assessment studies, Sustainable habitat, Green buildings, green materials, Energy, Conventional and renewable sources, Sustainable urbanization, Industrial Ecology.

### **Module 1**

Sustainability: Introduction, concept, evolution of the concept; Social, environmental and economic sustainability concepts; Sustainable development, Nexus between Technology and Sustainable development; Millennium Development Goals (MDGs) and Sustainable Development Goals (SDGs), Clean Development Mechanism (CDM).

### **Module 2**

Environmental Pollution: Air Pollution and its effects, Water pollution and its sources, Zero waste concept and 3 R concepts in solid waste management; Greenhouse effect, Global warming, Climate change, Ozone layer depletion, Carbon credits, carbon trading and carbon foot print, legal provisions for environmental protection.

### **Module 3**

Environmental management standards: ISO 14001:2015 frame work and benefits, Scope and goal of Life Cycle Analysis (LCA), Circular economy, Bio-mimicking, Environment Impact Assessment (EIA), Industrial ecology and industrial symbiosis.

### **Module 4**

Resources and its utilisation: Basic concepts of Conventional and non-conventional energy, General idea about solar energy, Fuel cells, Wind energy, Small hydro plants, bio-fuels, Energy derived from oceans and Geothermal energy.

### **Module 5**

Sustainability practices: Basic concept of sustainable habitat, Methods for increasing energy efficiency in buildings, Green Engineering, Sustainable Urbanisation, Sustainable cities, Sustainable transport.

## **Reference Books**

1. Allen, D. T. and Shonnard, D. R., Sustainability Engineering: Concepts, Design and Case Studies, Prentice Hall.
2. Bradley. A.S; Adebayo,A.O., Maria, P. Engineering applications in sustainable design and development, Cengage learning
3. Environment Impact Assessment Guidelines, Notification of Government of India, 2006
4. Mackenthun, K.M., Basic Concepts in Environmental Management, Lewis Publication, London, 1998
5. ECBC Code 2007, Bureau of Energy Efficiency, New Delhi Bureau of Energy Efficiency Publications-Rating System, TERI Publications - GRIHA Rating System
6. Ni bin Chang, Systems Analysis for Sustainable Engineering: Theory and Applications, McGraw-Hill Professional.
7. Twidell, J. W. and Weir, A. D., Renewable Energy Resources, English Language Book Society (ELBS).
8. Purohit, S. S., Green Technology - An approach for sustainable environment, Agrobios Publication

### Course Contents and Lecture Schedule

No	Topic	No. of Lectures
1	Sustainability	
1.1	Introduction, concept, evolution of the concept	1
1.2	Social, environmental and economic sustainability concepts	1
1.3	Sustainable development, Nexus between Technology and Sustainable development	1
1.4	Millennium Development Goals (MDGs) and Sustainable Development Goals (SDGs)	1
1.5	Clean Development Mechanism (CDM)	1
2	Environmental Pollution	
2.1	Air Pollution and its effects	1
2.2	Water pollution and its sources	1
2.3	Zero waste concept and 3 R concepts in solid waste management	1
2.4	Greenhouse effect, Global warming, Climate change, Ozone layer depletion	1
2.5	Carbon credits, carbon trading and carbon foot print.	1
2.6	Legal provisions for environmental protection.	1
3	Environmental management standards	
3.1	Environmental management standards	1
3.2	ISO 14001:2015 frame work and benefits	1
3.3	Scope and Goal of Life Cycle Analysis (LCA)	1
3.4	Circular economy, Bio-mimicking	1
3.5	Environment Impact Assessment (EIA)	1
3.6	Industrial Ecology, Industrial Symbiosis	1
4	Resources and its utilisation	
4.1	Basic concepts of Conventional and non-conventional energy	1
4.2	General idea about solar energy, Fuel cells	1
4.3	Wind energy, Small hydro plants, bio-fuels	1
4.4	Energy derived from oceans and Geothermal energy	1
5	Sustainability Practices	
5.1	Basic concept of sustainable habitat	1
5.2	Methods for increasing energy efficiency of buildings	1
5.3	Green Engineering	1
5.4	Sustainable Urbanisation, Sustainable cities, Sustainable transport	1

COURSE CODE	COURSE NAME	CATEGORY	L	T	P	CREDITS
22MEL308	COMPUTER AIDED MACHINE DRAWING	ES	0	0	3	2

**Preamble:** To introduce students to the basics and standards of engineering drawing related to machines and components.

To make students familiarize with different types of riveted and welded joints, surface roughness symbols; limits, fits and tolerances.

To convey the principles and requirements of machine and production drawings.

To introduce the preparation of drawings of assembled and disassembled view of important valves and machine components used in mechanical engineering applications.

To introduce standard CAD packages for drafting and modeling of engineering components.

**Prerequisite:** EST 110 - Engineering Graphics

**Course Outcomes -** At the end of the course students will be able to

CO1	Apply the knowledge of engineering drawings and standards to prepare standard dimensioned drawings of machine parts and other engineering components.
CO2	Prepare standard assembly drawings of machine components and valves using part drawings and bill of materials.
CO3	Apply limits and tolerances to components and choose appropriate fits for given assemblies
CO 4	Interpret the symbols of welded, machining and surface roughness on the component drawings.
CO 5	Prepare part and assembly drawings and Bill of Materials of machine components and valves using CAD software.

### Mapping of course outcomes with program outcomes (Minimum requirements)

	PO1	PO2	PO3	PO4	PO5	PO6	PO7	PO8	PO9	PO10	PO11	PO12
CO1	3									3		
CO2	3		2							3		
CO3	3	2										
CO4	3											
CO5	3				3					3		1

## Assessment Pattern

Bloom's taxonomy	Continuous Assessment Tests	
	Test 1 <u>PART A</u> <u>Sketching and Manual</u> <u>Drawing</u>	Test 2 <u>PART B</u> <u>CAD Drawing</u>
Remember	25	20
Understand	15	15
Apply	30	20
Analyse	10	10
Evaluate	10	15
Create	10	20

## Mark Distribution

Total Marks	CIE Marks	ESE marks	ESE duration
150	75	75	2.5 hours

## Continuous Internal Evaluation (CIE) Pattern:

Attendance	15 marks
Regular class work/Drawing/Workshop Record/Lab Record and Class Performance	30 marks
Continuous Assessment Test (minimum two tests)	30 marks

## End semester examination pattern

End semester examination shall be conducted on Sketching and CAD drawing on based complete syllabus

The following general guidelines should be maintained for the award of marks

- Part A Sketching – 15 marks
- Part B CAD drawing – 50marks
- Viva Voce – 10 marks.

## Conduct of University Practical Examinations

The Principals of the concerned Engineering Colleges with the help of the Chairmen/Chairperson will conduct the practical examination with the approval from the University and bonafide work / laboratory record, hall ticket, identity card issued by college are mandatory for appearing practical University examinations. No practical examination should be conducted without the presence of an external examiner appointed by the University.



**END SEMSTER EXAMINATION**

**MODEL QUESTION PAPER**

**MEL 201: COMPUTER AIDED MACHINE DRAWING**

Duration : 2.5 hours

Marks : 75

Note :

1. All dimensions in mm
2. Assume missing dimensions appropriately
3. A4 size answer booklet shall be supplied
4. Viva Voce shall be conducted for 10 marks

**PART A (SKETCHING)**  
**(Answer any TWO questions ).**

**15 marks**

1. Sketch two views of a single riveted single strap butt joint. Take dimensions of the plate as 10mm. Mark the proportions in the drawing.
2. Show by means of neat sketches, any three methods employed for preventing nuts from getting loose on account of vibrations
3. Compute the limit dimensions of the shaft and the hole for a clearance fit based on shaft basis system if:

Basic size=  $\phi 30$  mm  
Minimum clearance = 0.007 mm  
Tolerance on hole = 0.021 mm  
Tolerance on shaft= 0.021 mm

Check the calculated dimensions. Represent the limit dimensions schematically.

**PART B (CAD DRAWING)**

**50 marks**

4. Draw any two assembled views of the Rams Bottom Safety Valve as per the details given in the figure using any suitable CAD software. Also prepare bill of materials and tolerance data sheet.

Item	Description	Qty	Material	Item	Description	Qty	Material
1	Body	1	C.I.	8	Split Pin	3	M.S.
2	Valve Seat	2	G.M.	9	Pin for Link	2	M.S.
3	Spring	1	Steel	10	Pin for Pivot	1	M.S.
4	Valve	2	G.M.	11	Shackle	1	M.S.
5	Lever	1	M.S.	12	Washer	1	M.S.
6	Pivot	1	M.S.	13	Nut	1	M.S.
7	Link	2	M.S.	14	Lock Nut	1	M.S.

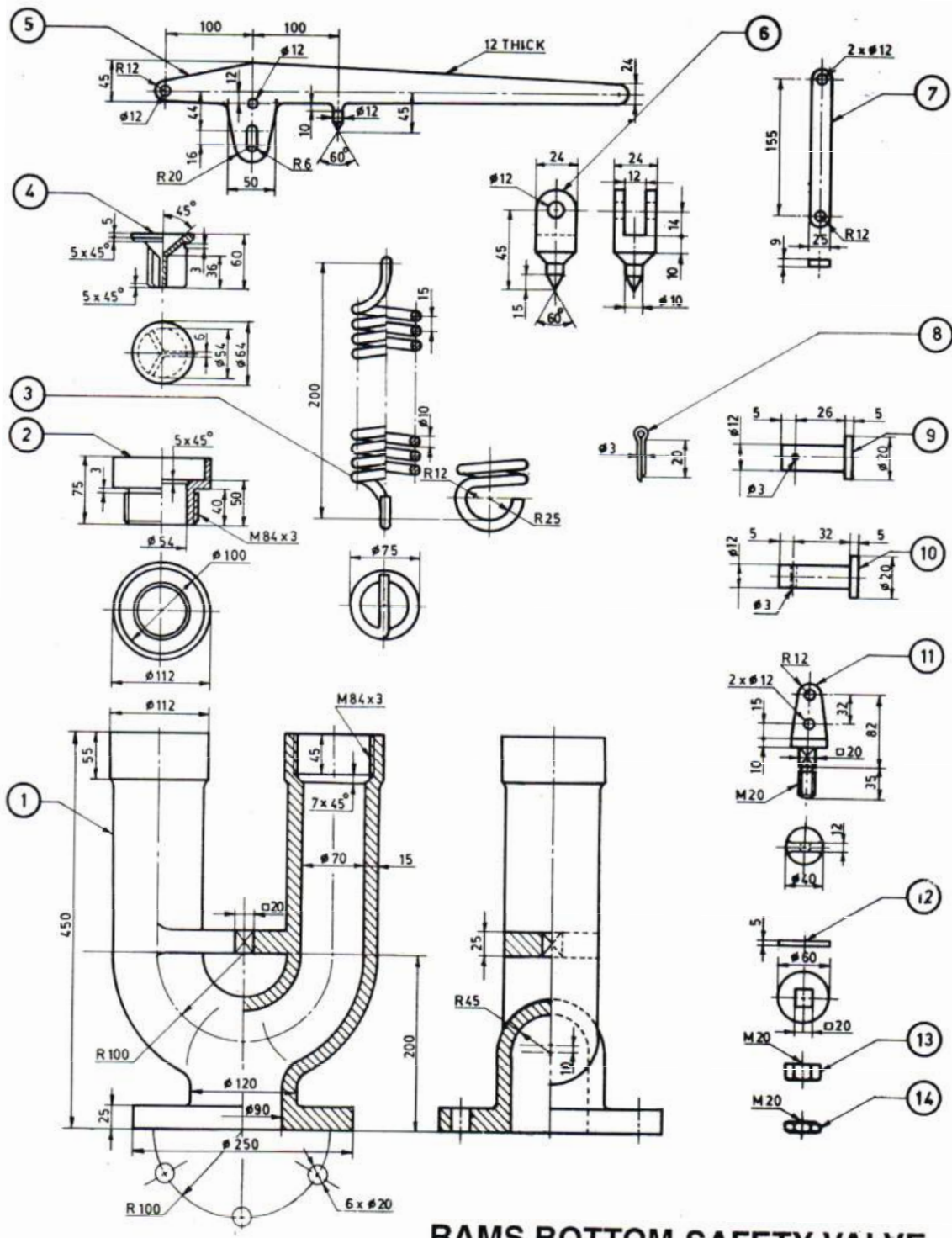

**RAMS BOTTOM SAFETY VALVE**

## SYLLABUS

Introduction to machine drawing, drawing standards, fits, tolerances, surface roughness, assembly and part drawings of simple assemblies and subassemblies of machine parts viz., couplings, clutches, bearings, I.C. engine components, valves, machine tools, etc; introduction to CAD etc.

### Text Books:

1. N. D. Bhatt and V.M. Panchal, Machine Drawing, Charotar Publishing House.
2. P I Varghese and K C John, Machine Drawing, VIP Publishers.

### Reference Books

1. Ajeet Singh, Machine Drawing Includes AutoCAD, Tata McGraw-hill.
2. P S Gill, Machine Drawing, Kataria& Sons.

### Course content and drawing schedules.

No:	List of Exercises	Course outcomes	No. of hours
	<b>PART –A (Manual drawing)</b> <i>(Minimum 6 drawings compulsory)</i>		
1	<b>Temporary Joint:</b> Principles of drawing, free hand sketching, Importance of machine Drawing. BIScode of practice for Engineering Drawing, lines, types of lines, dimensioning, scales of drawing, sectional views, <b>Riveted joints.</b>	CO 1	3
2	<b>Fasteners:</b> Sketching of conventional representation of welded joints, Bolts and Nuts <b>or</b> Keys and Foundation Bolts.	CO 1	3
3	<b>Fits and Tolerances:</b> Limits, Fits – Tolerances of individual dimensions – Specification of Fits – basic principles of geometric & dimensional tolerances. <b>Surface Roughness:</b> Preparation of production drawings and reading of part and assembly drawings, surface roughness, indication of surface roughness, etc.	CO 2	3
4	Detailed drawing of Cotter joints, Knuckle joint and Pipe joints	CO 2	3
5	<b>Assembly drawings(2D):</b> Stuffing box and Screw jack	CO 1 CO3 CO4	3

	<b>PART –B (CAD drawing)</b> <i>(Minimum 6 drawings compulsory)</i>		
<b>6</b>	Introduction to drafting software like Auto CAD, basic commands, keyboard shortcuts. Coordinate and unit setting, Drawing, Editing, Measuring, Dimensioning, Plotting Commands, Layering Concepts, Matching, Detailing, Detailed drawings.	CO 1 CO 2 CO 3 CO5	<b>3</b>
<b>7</b>	Drawing of Shaft couplings and Oldham's coupling	CO 1 CO 2 CO 3 CO5	<b>3</b>
<b>8</b>	<b>Assembly drawings(2D)with Bill of materials:</b> Lathe Tailstock and Universal joint	CO 1 CO3 CO5	<b>3</b>
<b>9</b>	<b>Assembly drawings(2D)with Bill of materials:</b> Connecting rod and Plummer block	CO 1 CO3 CO5	<b>3</b>
<b>10</b>	<b>Assembly drawings(2D)with Bill of materials:</b> Rams Bottom Safety Valve <b>OR</b> steam stop valve	CO 1 CO3 CO5	<b>3</b>

COURSE CODE	COURSE NAME	CATEGORY	L	T	P	CREDITS
22MEL309	MATERIAL TESTING LAB	ES	0	0	3	2

### Preamble:

The objective of this course is to give a broad understanding of common materials related to mechanical engineering with an emphasis on the fundamentals of structure-property-application and its relationships. A group of 6/7 students can conduct experiment effectively. A total of six experiments for the duration of 2 hours each is proposed for this course.

**Prerequisite:** A course on Engineering Mechanics is required

### Course Outcomes:

After the completion of the course the student will be able to

<b>CO 1</b>	To understand the basic concepts of analysis of circular shafts subjected to torsion.
<b>CO 2</b>	To understand the behaviour of engineering component subjected to cyclic loading and failure concepts
<b>CO 3</b>	Evaluate the strength of ductile and brittle materials subjected to compressive, Tensile shear and bending forces
<b>CO 4</b>	Evaluate the microstructural morphology of ductile or brittle materials and its fracture modes (ductile /brittle fracture) during tension test
<b>CO 5</b>	To specify suitable material for applications in the field of design and manufacturing.

### Mapping of course outcomes with program outcomes

	PO 1	PO 2	PO 3	PO 4	PO 5	PO 6	PO 7	PO 8	PO 9	PO 10	PO 11	PO 12
<b>CO 1</b>	3				3							
<b>CO 2</b>	3	3	1		3				3	2	2	1
<b>CO 3</b>	3	3	3	1	3				3	2	3	2
<b>CO 4</b>	3	3	3	3	3	2	2	1	3	2	3	2
<b>CO 5</b>	3	3	3	1	3	2	2	1	3	2	3	2

### Assessment Pattern

#### Mark distribution

Total Marks	CIE	ESE	ESE Duration
150	75	75	2.5 hours

### **Continuous Internal Evaluation Pattern:**

Attendance	:	15 marks
Continuous Assessment	:	30 marks
Internal Test (Immediately before the second series test)	:	30 marks

### **End Semester Examination Pattern:**

The following guidelines should be followed regarding award of marks

(a) Preliminary work	:	15 Marks
(b) Implementing the work/Conducting the experiment	:	10 Marks
(c) Performance, result and inference (usage of equipments and troubleshooting)	:	25 Marks
(d) Viva voce	:	20 marks
(e) Record	:	5 Marks

### **General instructions:**

Practical examination to be conducted immediately after the second series test covering entire syllabus given below. Evaluation is a serious process that is to be conducted under the equal responsibility of both the internal and external examiners. The number of candidates evaluated per day should not exceed 20. Students shall be allowed for the University examination only on submitting the duly certified record. The external examiner shall endorse the record.

A minimum of 10 experiments are to be performed.

## **SYLLABUS**

### **LIST OF EXPERIMENTS**

1. To conduct tension test on ductile material (mild steel/ tor-steel/ high strength steel) using Universal tension testing machine and Extensometer.
2. To conduct compression test on ductile material (mild steel/ tor-steel/ high strength steel) using Universal tension testing machine and Extensometer.
3. To conduct tension test on Brittle material (cast iron) using Universal tension testing machine and Extensometer.
4. To conduct shear test on mild steel rod.
5. To conduct microstructure features of mild steel/copper/ brass/aluminium using optical microscope, double disc polishing machine, emery papers and etchant.
6. To conduct fractography study of ductile or brittle material using optical microscope.

7. To conduct Hardness test of a given material. (Brinell, Vickers and Rockwell)
8. To determine torsional rigidity of mild steel/copper/brass rod.
9. To determine flexural rigidity of mild steel/ copper/brass material using universal testing machine.
10. To determine fracture toughness of the given material using Universal tension testing machine.
11. To study the procedure for plotting S-N curve using Fatigue testing machine.
12. To conduct a Toughness test of the given material using Izod and Charpy Machine.
13. To determine spring stiffness of close coiled/open coiled/series/parallel arrangements.
14. To conduct bending test on wooden beam.
15. To conduct stress measurements using Photo elastic methods.
16. To conduct strain measurements using strain gauges.
17. To determine moment of inertia of rotating bodies.
18. To conduct an experiment to Verify Clerk Maxwell's law of reciprocal deflection and determine young's Modulus of steel.
19. To determine the surface roughness of a polished specimen using surface profilometer.

### **Reference Books**

1. G E Dieter. Mechanical Metallurgy, McGraw Hill,2013
2. Dally J W, Railey W P, Experimental Stress analysis , McGarw Hill,1991
3. Baldev Raj, Jayakumar T, Thavasimuthu M., Practical Non destructive testing, Narosa Book Distributors,2015

**SEMESTER -3**  
**MINOR**





## Assessment Pattern

Bloom's Category	Continuous Assessment Tests		End Semester Examination
	1	2	
Remember	10	10	20
Understand	20	20	50
Apply	20	20	30
Analyse			
Evaluate			
Create			

### Mark distribution

Total Marks	CIE	ESE	ESE Duration
150	50	100	3 hours

### Continuous Internal Evaluation Pattern:

Attendance	: 10 marks
Continuous Assessment Test (2 numbers)	: 25 marks
Assignment/Quiz/Course project	: 15 marks

**End Semester Examination Pattern:** There will be two parts; Part A and Part B. Part A contain 10 questions with 2 questions from each module, having 3 marks for each question. Students should answer all questions. Part B contains 2 questions from each module of which student should answer any one. Each question can have maximum 2 sub-divisions and carry 14 marks.

## **COURSE LEVEL ASSESSMENT QUESTIONS**

### **Course Outcome 1 (CO1):**

1. Discuss normal strain and shear strain.
2. Determine the deformation of axially loaded bars.
3. State the principle of superposition.

### **Course Outcome 2 (CO2)**

1. Compare the strength of a hollow shaft and a solid shaft.
2. List four important assumptions in the theory of torsion.
3. Determine the shear stress developed in a circular shaft subjected to torsional loading.

### **Course Outcome 3 (CO3):**

1. Draw the Shear Force Diagram and Bending Moment Diagram of a beam.
2. Determine the bending stress and shear stresses in beams.
3. Explain pure bending with example.

### **Course Outcome 4 (CO4):**

1. Estimate the deflection of the beam.
2. Discuss principal planes and principal stresses.
3. Determine principal stresses, maximum shear stress, plane of maximum shear stress and the resultant stress on the plane of maximum shear stress

### **Course Outcome 5 (CO5):**

1. Draw the Mohr's circle.
2. Discuss the behaviour of structures under compound loading.
3. Calculate the safe buckling load.

## MODEL QUESTION PAPER

### THIRD SEMESTER MECHANICAL ENGINEERING

Time: 3 hrs

### MET281 MECHANICS OF MATERIALS

Max. Marks: 100

#### PART – A

**(ANSWER ALL QUESTIONS, EACH QUESTION CARRIES 3 MARKS)**

1. Discuss the significance of Poisson's ratio.
2. Explain Hooke's law for linearly elastic isotropic material.
3. List the important assumptions in the theory of torsion.
4. Explain the term 'point of inflection'.
5. Define i) section modulus and ii) flexural rigidity
6. Explain how shear stress is distributed over the cross section of a rectangular beam.
7. Explain how double integration method can be used to obtain slope and deflection of beams.
8. Define principal stresses and principal planes and explain its significance
9. Draw the Mohr's circle for uniaxial tensile load acting on a mild steel bar.
10. Write a short note on Rankine's crippling load for a column.

#### PART – B

**(ANSWER ONE FULL QUESTION FROM EACH MODULE)**

##### MODULE – 1

11. a) Draw a typical stress strain curve for mild steel under tension, describing briefly the salient points . (7 marks)
- b) A steel bar is fastened between two copper bars as shown in figure. The assembly is subjected to loads at positions as in figure. Calculate the total deformation of the bar and stresses at each section.  $E_{\text{steel}} = 200 \text{ GPa}$  and  $E_{\text{copper}} = 110 \text{ GPa}$ . (7 marks)



OR

12. a) A bar made of brass and steel as shown in figure is held between two rigid supports A and C. Find the stresses in each material if the temperature rises by  $40^\circ\text{C}$ . Take  $E_b = 1 \times 10^5 \text{ N/mm}^2$ ;  $\alpha_b = 19 \times 10^{-6} / ^\circ\text{C}$ ,  $E_s = 2 \times 10^5 \text{ N/mm}^2$ ;  $\alpha_s = 12 \times 10^{-6} / ^\circ\text{C}$ . (9 marks)

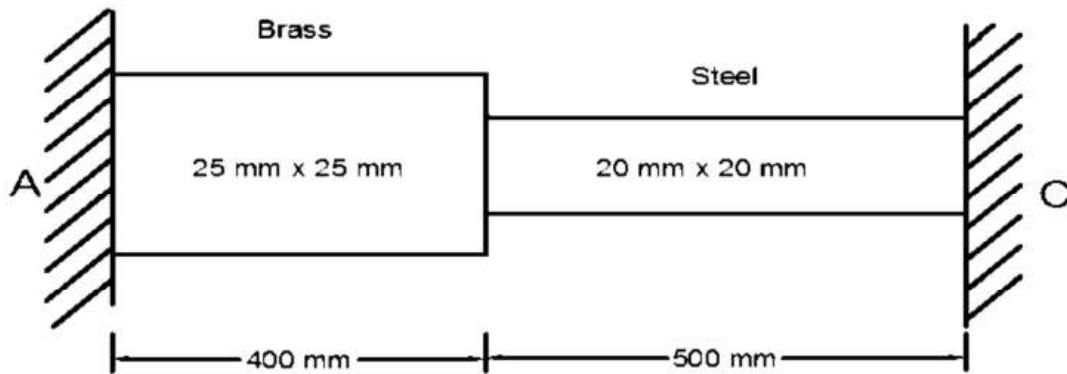

- b) A straight bar 450 mm long is 40 mm in diameter for the first 250 mm length and 20 mm diameter for the remaining length. If the bar is subjected to an axial pull of 15 kN, find the maximum and minimum stresses produced in it and the total extension of the bar. Take  $E = 2 \times 10^5 \text{ N/mm}^2$ . (5 marks)

#### MODULE – 2

13. a) A solid aluminium shaft 1 m long and 50 mm diameter is to be replaced by a tubular steel shaft of the same length and the same outside diameter such that each of the two shafts could have the same angle of twist per unit torsional moment over the total length. What must the inner diameter of the tubular steel shaft be? Modulus of rigidity of the steel is three times that of aluminium. (10 marks)
- b) A solid steel shaft transmits 20 kW at 120 rpm. Determine the smallest safe diameter of the shaft if the shear stress is not to exceed 40 MPa. (4 marks)

OR

14. a) Draw shear force and bending moment diagram for the beam given in the figure and mark all the salient points. (10 marks)

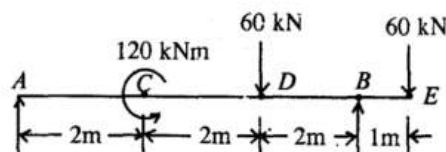

- b) Explain the sign conventions used for shear forces and bending moments. (4 marks)

#### MODULE – 3

15. a) Derive the flexure formula for pure bending of a beam. State the assumptions (9 marks)
- b) A rolled steel joist of I section has the dimensions as shown in figure. The beam carries a uniformly distributed load of  $40 \text{ kN/m}^2$  run on a span of 10 m, calculate the maximum stress produced due to bending. (5 marks)

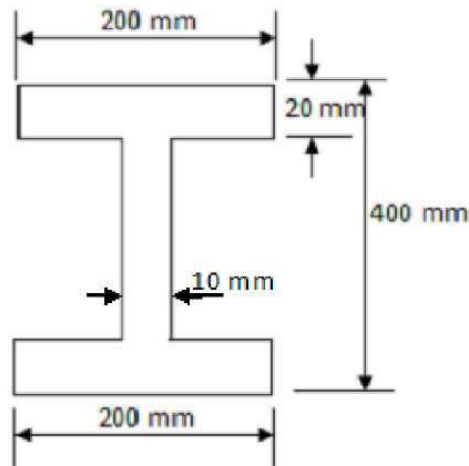

OR

16. a) At the critical section of a beam of rectangular cross section with height 200 mm and width 100 mm, the value of the vertical shear force is 40 kN. Draw the shear stress distribution across the depth of the section. (9 marks)
- b) Derive the expression for shear stress in a beam. (5 marks)

MODULE – 4

17. a) A horizontal girder of steel having uniform section is 14 m long and is simply supported at its ends. It carries concentrated loads of 120 kN and 80 kN at two points 3 m and 4.5 m from the two ends respectively. Moment of inertia for the section of the girder is  $16 \times 10^8 \text{ mm}^4$  and  $E_s = 210 \text{ kN/mm}^2$ . Calculate the deflection of the girder at points under the two loads and maximum deflection using Macaulay's method. (10 marks)
- b) A rectangular block of material is subjected to a tensile stress of  $110 \text{ N/mm}^2$  on one plane and a tensile stress of  $47 \text{ N/mm}^2$  on a plane at right angles, together with shear stresses of  $63 \text{ N/mm}^2$  on the same planes. Find the magnitude of the principal stresses and maximum shear stress. (4 marks)

OR

18. a) Derive the transformation equations to determine normal and shear stress on an oblique plane. (10 marks)
- b) Define state of stress at point. Show the components of stress on a 3D rectangular element (4 marks)

MODULE – 5

19. a) At a point in a bracket the stresses on two mutually perpendicular planes are  $120 \text{ N/mm}^2$  and  $60 \text{ N/mm}^2$  both tensile. The shear stress across these planes is  $30 \text{ N/mm}^2$ . Find using the Mohr's stress circle i) Principal stresses at the point, ii) Maximum shear stress and iii) resultant stress on a plane inclined at  $60^\circ$  to the axis of the major principal stress. (10 marks)

b) Explain with the help of an example, how to calculate the normal stress when axial and transverse loads act simultaneously. (4 marks)

OR

20. a) Find the crippling load for a hollow steel column 50mm internal diameter and 5mm thick. The column is 5m long with one end fixed and other end hinged. Use Rankine's formula and Rankine's constant as  $1/7500$  and  $\sigma_c = 335 \text{ N/mm}^2$ . (9 marks)
- b) Derive Euler's formula for a column with both ends hinged. (5 marks)

# SYLLABUS

## Module 1

Introduction to analysis of deformable bodies – internal forces – method of sections – assumptions and limitations. Stress – stresses due to normal, shear and bearing loads – strength design of simple members. Definition of linear and shear strains.

Material behavior – uniaxial tension test – stress-strain diagrams – Hooke's law for linearly elastic isotropic material under axial and shear deformation, Poisson's ratio, Relationship between Young's modulus, Poisson's ratio and rigidity modulus (no derivations)

Deformation in axially loaded bars – thermal effects – statically indeterminate problems – principle of superposition.

## Module 2

Torsion: Shafts - torsion theory of elastic circular bars – assumptions and limitations – polar modulus - torsional rigidity – economic cross-sections – statically indeterminate problems – shaft design for torsional load.

Beams- classification - diagrammatic conventions for supports and loading - axial force, shear force and bending moment in a beam.

Shear force and bending moment diagrams for simply supported, cantilever and overhanging beams (with concentrated loads, moment and uniformly distributed loads only), point of inflection and contraflexure

## Module 3

Stresses in beams: Pure bending – flexure formula for beams assumptions and limitations – section modulus – flexural rigidity – economic sections, Problems to calculate bending stress for rectangular and I cross sections.

Shearing stress formula for beams – assumptions and limitations – Problems to calculate shear stress for beams of rectangular cross section.

## Module 4

Deflection of beams: Moment-curvature relation – assumptions and limitations - double integration method – Macaulay's method.

Transformation of stress and strains: Definition of state of stress at a point (introduction to stress and strain tensors and its components only) -plane stress – plane strain - equations of transformation (2D) - principal planes and stresses - analogy between stress and strain transformation

## Module 5

Mohr's circles of stress (2D)

Compound stresses: Combined axial, flexural and shear loads – combined bending and twisting loads.



Theory of columns: Buckling theory – Euler’s formula for long columns – assumptions and limitations – effect of end conditions – slenderness ratio – Rankine’s formula for intermediate columns.

### **Text Books**

1. S.S Rattan, “Strength of Materials”, McGraw Hill, 2<sup>nd</sup> edition, 2011.

### **Reference Books**

1. Surya Patnaik, Dale Hopkins, Strength of Materials, Butterworth-Heinemann, 1<sup>st</sup> edition, 2003.
2. S. H. Crandal, N. C. Dhal, T. J. Lardner, An introduction to the Mechanics of Solids, McGraw Hill, 1999.
3. Mechanics of Materials, Pytel A. and Kiusalaas J. Cengage Learning India Private Limited, 2<sup>nd</sup> Edition, 2015
4. R. C. Hibbeler, Mechanics of Materials, Pearson Education, 2008.
5. I.H. Shames, J. H. Pitarresi, Introduction to Solid Mechanics, PHI, 2006.
6. James M. Gere, Mechanics of Materials, Brooks/Cole–Thomson Learning, 2004.
7. F. P. Beer, E. R. Johnston, J. T. DeWolf, Mechanics of Materials, Tata McGraw Hill, 2011.
8. MIT Open Courseware web course <http://web.mit.edu/emech/dontindex-build/>
9. Egor P. Popov, “Engineering Mechanics of Solids”, PHI, 2<sup>nd</sup> edition, 2002.

## COURSE CONTENTS AND LECTURE SCHEDULE

No	Topic	No. of Lectures
<b>1</b>	<b>Module 1: Introduction to Stress and Strain Analysis</b>	<b>9</b>
1.1	Introduction to analysis of deformable bodies – internal forces – method of sections – assumptions and limitations.	1
1.2	Stress – stresses due to normal, shear and bearing loads – strength design of simple members. Definition of linear and shear strains.	2
1.3	Material behavior – uniaxial tension test – stress-strain diagrams for ductile and brittle materials under axial loading, significance of various points on the diagram	1
1.4	Hooke's law for linearly elastic isotropic material under axial and shear deformation, Poisson's ratio.	1
1.5	Relationship between Young's modulus, Poisson's ratio and rigidity modulus(no derivations)	1
1.6	Deformation in axially loaded bars – thermal effects – statically indeterminate problems – principle of superposition	3
<b>2</b>	<b>Module 2: Torsion and Introduction to beams</b>	<b>9</b>
2.1	Introduction to Torsion of Shafts – torsion theory of elastic circular bars – assumptions and limitations	1
2.2	Polar modulus - torsional rigidity – economic cross-sections – statically indeterminate problems	2
2.3	Shaft design for torsional load and numerical problems	1
2.4	Introduction to beam bending – sign conventions for supports, loads and moments, classifications of beams, demonstration of the behaviour of beams for various types of loads	2
2.5	Shear force and bending moment diagrams for simply supported, cantilever and overhanging beams (with concentrated loads, moment and uniformly distributed loads only), point of inflection and contraflexure (simple problems to draw the SF and BM diagrams)	3
<b>3</b>	<b>Module 3: Beam Bending</b>	<b>9</b>
3.1	Stresses in beams: Pure bending – flexure formula for beams assumptions, limitations and derivation	3
3.2	Section modulus – flexural rigidity – economic sections –, numerical problems to analyze the strength of beams (rectangular and I sections only)	3
3.3	Shearing stress in beams – assumptions and limitations – derivation of formula for shear stress, problems to calculate shear stress for beams of rectangular cross section	3
<b>4</b>	<b>Module 4: Deflection of Beams and Stress-Strain transformations</b>	<b>9</b>
4.1	Introduction to deflection of beams: Moment-curvature relation – assumptions and limitations	1

4.2	Double integration method – Macaulay’s method – Simple problems to calculate deflection of cantilever and simply supported beams subjected to point load, moment and UDL	3
4.3	Definition of stress at a point (introduction to stress and strain tensors and its components only), plane stress, plane strain	2
4.4	Stress and strain transformations in 2D – transformation equations - analogy between stress and strain transformation	1
4.5	Determination of principal stresses and principal planes	2
<b>5</b>	<b>Module 5: Mohr’s Circle, Compound Stress and Column Buckling</b>	<b>9</b>
5.1	Mohr’s circles of stress (2D) – problems	2
5.2	Compound stresses: Combined axial, flexural and shear loads – discussion of practical situations of combined loading and compound stresses	2
5.3	Combined bending and twisting loads	1
5.4	Introduction to Buckling of columns – Buckling theory – Euler’s formula for long columns – assumptions and limitations	2
5.5	Effect of end conditions – slenderness ratio – Rankine’s formula for intermediate columns – numerical problems for maximum buckling	2

COURSE CODE	COURSE NAME	CATEGORY	L	T	P	CREDITS
22MEMR310.2	FLUID MECHANICS & MACHINERY	MR	3	1	0	4

**Preamble:**

This course provides an introduction to the properties and behaviour of fluids. It enables to apply the concepts in engineering. The course also gives an introduction of hydraulic pumps and turbines.

**Prerequisite:** NIL

**Course Outcomes:**

After the completion of the course the student will be able to

<b>CO 1</b>	Define Properties of Fluids and Solve hydrostatic problems
<b>CO 2</b>	Explain fluid kinematics and Classify fluid flows
<b>CO 3</b>	Interpret Euler’s equation and Solve problems using Bernoulli’s equation
<b>CO 4</b>	Explain the working of turbines and Select a turbine for specific application.
<b>CO 5</b>	Explain the characteristics of centrifugal and reciprocating pumps

**Mapping of course outcomes with program outcomes**

	PO 1	PO 2	PO 3	PO 4	PO 5	PO 6	PO 7	PO 8	PO 9	PO 10	PO 11	PO 12
<b>CO 1</b>	3	2										
<b>CO 2</b>	3	2	1									
<b>CO 3</b>	3	2	1									
<b>CO 4</b>	3	2	1									
<b>CO 5</b>	3	2	1									

**Assessment Pattern**

Bloom’s Category	Continuous Assessment Tests		End Semester Examination
	1	2	
Remember	10	10	10
Understand	20	20	20
Apply	20	20	70
Analyse			
Evaluate			
Create			

### Mark distribution

Total Marks	CIE	ESE	ESE Duration
150	50	100	3 hours

### Continuous Internal Evaluation Pattern:

Attendance	: 10 marks
Continuous Assessment Test (2 numbers)	: 25 marks
Assignment/Quiz/Course project	: 15 marks

### End Semester Examination Pattern:

There will be two parts; Part A and Part B. Part A contain 10 questions with 2 questions from each module, having 3 marks for each question. Students should answer all questions. Part B contains 2 questions from each module of which student should answer any one. Each question can have maximum 2 sub-divisions and carry 14 marks.

## COURSE LEVEL ASSESSMENT QUESTIONS

### Course Outcome 1

1. Define total pressure on a surface and center of pressure on a surface. What do you understand by the term hydrostatic pressure ?
2. An isosceles triangle of base 3m and altitude 6m is immersed vertically in water with its axis of symmetry horizontal. If the head on its axis is 9m, locate the center of pressure.
3. A triangular plate of 2m base and 2.5m altitude is immersed in water at an inclination of  $30^\circ$  with the base parallel to and at a depth of 2m from the free surface. Find the total hydrostatic force on the side of the plate and the position of its action.

### Course Outcome 2

1. Define the following and give one practical example for each of the following:
  - (a) laminar flow
  - (b) Turbulent flow
  - (c) Steady flow
  - (d) Uniform flow
2. A two dimensional flow is described by the velocity components,  $u = 5x^3; v = -15x^2y$ . Evaluate the stream function, velocity, and acceleration at point P(1,2).
3. For the velocity components  $u = ay \sin(xy)$  and  $v = ax \sin(xy)$ , obtain an expression for the velocity potential function.

### Course Outcome 3

1. Derive the Euler's equation of motion along a streamline and from that derive the Bernouli's equation.
2. Oil of specific gravity 0.8 flows through a 0.2 m diameter pipe under a pressure of 100 KPa. If the datum is 5 m below the center line of the pipe and the total energy with respect to the datum is 35 N m/N. Calculate the discharge.
3. A siphon consisting of a pipe of 15 cm diameter is used to empty kerosene oil (relative density=0.8) from tank A. The siphon discharges to the atmosphere at an elevation of 1.00 m. The oil surface in the tank is at an elevation of 4.00 m. The center line of the siphon pipe at its highest point C is at an elevation of 5.50 m. Estimate,

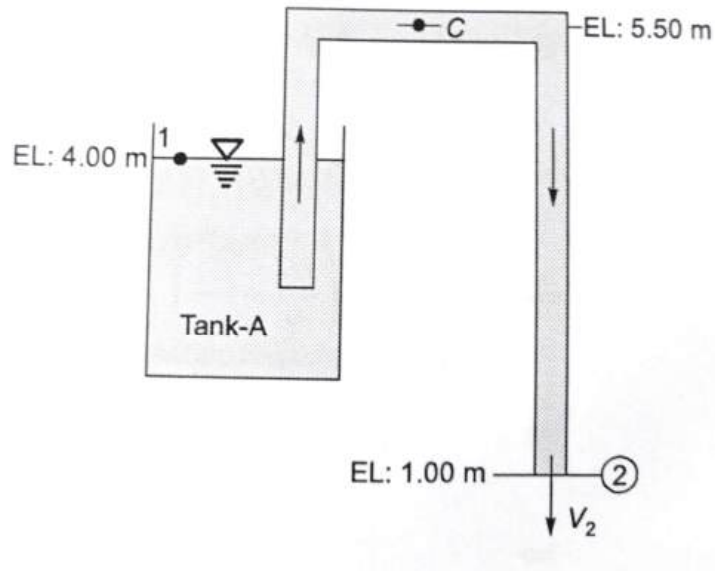

- (a) Discharge in the pipe
- (b) Pressure at point C.

#### Course Outcome 4

1. Differentiate between impulse and reaction turbine.
2. Prove that for a single jet Pelton wheel, the specific speed is given by the relation

$$N_s = 219.78 \frac{d}{D} \sqrt{\eta_o}$$

3. A Pelton wheel having semicircular buckets and working under a head of 120 m is running at 500 rpm. The discharge through the nozzle is 40 L/s and the diameter of the wheel is 50 cm. Find the following:
  - (a) The power available at the nozzle.
  - (b) Hydraulic efficiency of the wheel, if coefficient of velocity is 0.96.

#### Course Outcome 5

1. Distinguish between positive displacement pump and roto dynamic pump
2. Explain the phenomenon of cavitation and methods to avoid it
3. Explain the significance of NPSH in the installation of a centrifugal pump

# SYLLABUS

## Module 1

Fundamental concepts: Properties of fluid - density, specific weight, viscosity, surface tension, capillarity, vapour pressure, bulk modulus, compressibility, velocity, rate of shear strain, Newton's law of viscosity, Newtonian and non-Newtonian fluids, real and ideal fluids, incompressible and compressible fluids.

## Module 2

Fluid statics: Atmospheric pressure, gauge pressure and absolute pressure. Pascal's Law, measurement of pressure - piezo meter, manometers, pressure gauges, energies in flowing fluid, head - pressure, dynamic, static and total head, forces on planar surfaces immersed in fluids, centre of pressure, buoyancy, equilibrium of floating bodies, metacentre and metacentric height.

Fluid kinematics and dynamics: Classification of flow -1D, 2D and 3D flow, steady, unsteady, uniform, non-uniform, rotational, irrotational, laminar and turbulent flow, path line, streak line and stream line.

## Module 3

Continuity equation, Euler's equation, Bernoulli's equation. Reynolds experiment, Reynold's number. Hagen- Poiseuille equation, head loss due to friction, friction, Darcy- Weisbach equation, Chezy's formula, compounding pipes, branching of pipes, siphon effect, water hammer transmission of power through pipes (simple problems) .

Flow rate measurements- venturi and orifice meters, notches and weirs (description only for notches, weirs and meters), practical applications, velocity measurements- Pitot tube and Pitot – static tube.

## Module 4

Hydraulic turbines : Impact of jets on vanes - flat, curved, stationary and moving vanes - radial flow over vanes. Impulse and Reaction Turbines – Pelton Wheel constructional features - speed ratio, jet ratio & work done , losses and efficiencies, inward and outward flow reaction turbines- Francis turbine constructional features, work done and efficiencies – axial flow turbine (Kaplan) constructional features, work done and efficiencies, draft tubes, surge tanks, cavitation in turbines.



## Module 5

Positive displacement pumps: reciprocating pump, indicator diagram, air vessels and their purposes, slip, negative slip and work required and efficiency, effect of acceleration and friction on indicator diagram (no derivations), multi cylinder pumps.

Rotary pumps: –centrifugal pump, working principle, impeller, casings, manometric head, work, efficiency and losses, priming, specific speed, multistage pumps, selection of pumps, pump characteristics.

## Text Books

1. Mahesh Kumar, Fluid Mechanics and Machines, Pearson, 1<sup>st</sup> edition, 2019.
2. Pati, S., Textbook of Fluid Mechanics and Hydraulic Machines, Tata McGraw Hill, 1<sup>st</sup> Edition, 2017.

## Reference Books

1. Cimbala & Cengel, Fluid Mechanics: Fundamentals and Applications (4th edition, SIE) , McGraw Hill, 2019

## COURSE CONTENTS AND LECTURE SCHEDULE

No	Topic	No. of Lectures
1		
1.1	Fundamental concepts: Properties of fluid - density, specific weight, viscosity, surface tension, capillarity, vapour pressure	3
1.2	Bulk modulus, compressibility, velocity, rate of shear strain, Newton's law of viscosity	3
1.3	Newtonian and non-Newtonian fluids, real and ideal fluids, incompressible and compressible fluids.	3
2		
2.1	Fluid statics: Atmospheric pressure, gauge pressure and absolute pressure. Pascal's Law, measurement of pressure - piezo meter, manometers, pressure gauges, energies in flowing fluid	3
2.2	Head - pressure, dynamic, static and total head, forces on planar surfaces immersed in fluids, centre of pressure, buoyancy, equilibrium of floating bodies, metacentre and metacentric height.	3

2.3	Fluid kinematics and dynamics: Classification of flow -1D, 2D and 3D flow, steady, unsteady, uniform, non-uniform, rotational, irrotational, laminar and turbulent flow, path line, streak line and stream line	3
3		
3.1	Continuity equation, Euler's equation, Bernoulli's equation. Reynolds experiment, Reynold's number. Hagen- Poiseuille equation	3
3.2	Head loss due to friction, friction, Darcy- Weisbach equation, Chezy's formula, compounding pipes, branching of pipes, siphon effect, water hammer transmission of power through pipes (simple problems)	3
3.3	Flow rate measurements- venturi and orifice meters, notches and weirs (description only for notches, weirs and meters), practical applications, velocity measurements- Pitot tube and Pitot –static tube	3
4		
4.1	Hydraulic turbines: Impact of jets on vanes - flat, curved, stationary and moving vanes - radial flow over vanes	3
4.2	Impulse and Reaction Turbines – Pelton Wheel constructional features - speed ratio, jet ratio & work done, losses and efficiencies, inward and outward flow reaction turbines- Francis turbine constructional features, work done and efficiencies	3
4.3	Axial flow turbine (Kaplan) constructional features, work done and efficiencies, draft tubes, surge tanks, cavitation in turbines	3
5		
5.1	Positive displacement pumps: reciprocating pump, indicator diagram, air vessels and their purposes	3
5.2	Slip, negative slip and work required and efficiency, effect of acceleration and friction on indicator diagram (no derivations), multi cylinder pumps	3
5.3	Rotary pumps: –centrifugal pump, working principle, impeller, casings, manometric head, work, efficiency and losses, priming, specific speed, multistage pumps, selection of pumps, pump characteristics	3

**MODEL QUESTION PAPER**  
**IV SEMESTER B.TECH DEGREE EXAMINATION**  
**MET283: FLUID MECHANICS AND MACHINERY**

Maximum: 100 Marks

Duration: 3 hours

**PART A**

Answer all questions, each question carries 3 marks

1. Define a fluid. What is the difference between ideal and real fluid?
2. Explain the phenomena of capillarity, Obtain the expression for capillary rise of a liquid
3. Distinguish between gauge pressure and absolute pressure. Estimate in meters the depth below the surface of a lake at which the pressure is equal to twice atmospheric pressure.
4. Define and distinguish between Streamline Streak line and path line
5. Water escapes from large storage tank through a small drain hole in the bottom. If the water depth is 2m, what is the exit velocity? If a similar tank contained gasoline what would be the exit velocity?
6. Oil of specific gravity 0.8 flows through a 0.2m diameter pipe under a pressure of 100 kN/m<sup>2</sup>. If the datum is 5m below the center line of the pipe and the total energy with respect to the datum is 35m, Calculate the discharge.
7. Differentiate between impulse and reaction turbine
8. Explain the functions of Draft tube
9. Define slip and percentage slip of a reciprocating pump, what are the reasons for negative slip.
10. What are the different classifications of centrifugal pump?

(10×3=30 Marks)

## PART B

Answer one full question from each module

### MODULE-I

11. (a) Write a short note on surface tension. Derive expressions for the pressure
- within a droplet of water
  - inside a soap bubble
- (8 marks)
- (b) Define the term viscosity, on what factors does it depend and give the units in which it is expressed. (6 marks)
12. (a) A U-tube is made up of two capillaries of bores 1mm and 2.2mm respectively. The tube is held vertically with zero contact angle. It is partially filled with liquid of surface tension 0.06 N/m. If the estimated difference in the level of two menisci is 15mm, determine the mass density of the liquid. (7 marks)
- (b) A volume of  $3.2 \text{ m}^3$  of certain oil weighs 27.5kN. Calculate its
- mass density
  - weight density
  - Specific volume
  - Specific gravity
- If the kinematic viscosity of the oil is  $7 * 10^{-3}$  Stokes, what would be its dynamic viscosity in centipoises. (7 marks)

### MODULE-II

13. (a) A steel ball of radius 1 cm is hanging inside the water tank by means of a string attached to a hollow plastic ball having radius 3 cm weighing 10g floating at the free surface, as shown in Fig. Determine the tension in the string and volume of the plastic ball submerged in water. Take density of the steel ball to be  $7850 \text{ kg/m}^3$  (7 marks)

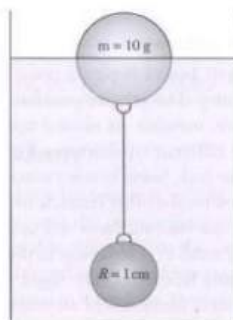

- (b) If the velocity distribution for a 2D ideal flow is given by  $u = \frac{x}{2+t}$ ,  $v = \frac{y}{1+3t}$  Obtain the equation of (a) the streamlines, (b) the pathlines, and (c) the streaklines that pass through point (1, 2) at  $t = 0$ . (7 marks)

14. (a) Find out the pressure difference between points A and B for the manometers shown in the figures

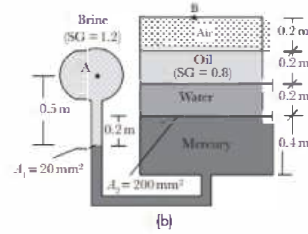
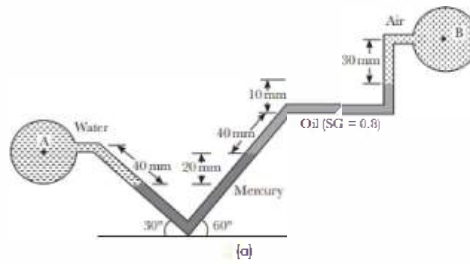

(7 marks)

- (b) Check whether the floating objects having specific gravity 0.8 shown in Fig. are stable or not.

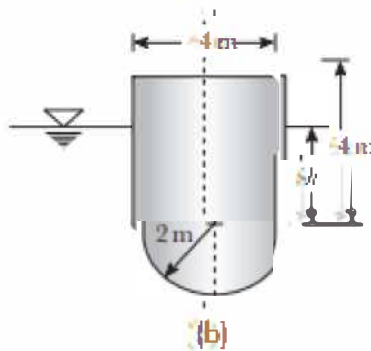
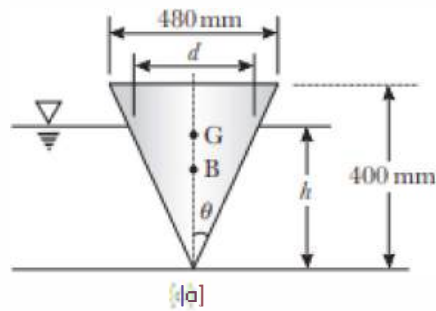

(7 marks)

### MODULE-III

15. (a) The maximum velocity for the viscous flow through a 200mm diameter pipe is 3m/s. Determine the average velocity and the radial distance from the pipe axis at which it occurs. In addition, determine the velocity at 25mm from the pipe wall. (7 marks)
- (b) Determine the discharge in each branch of the pipe network shown in Fig. Assume same friction factor  $f = 0.03$  in each pipe. (7 marks)

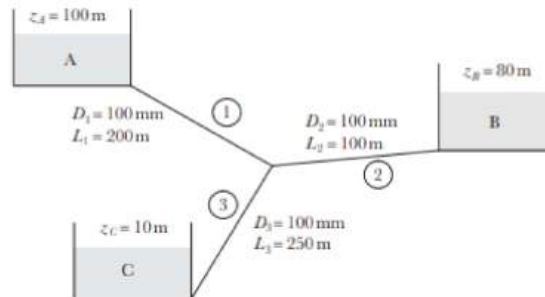

16. (a) Prove that for power transmission through pipes transmission power is maximum when head loss due to friction is one third of the power available at the inlet. (7 marks)
- (b) A 5km long water pipeline is used to transmit 200 kW of hydraulic power. If the pressure at the inlet is 6MPa and the pressure drop across the pipe length is 2MPa. Determine the pipe diameter and its transmission efficiency. Take the friction factor  $f = 0.04$  (7 marks)

### MODULE-IV

17. (a) A double jet Pelton wheel has a specific speed of 16 and is required to deliver 1200 kW. The turbine is supplied through a pipeline from a reservoir whose level is 380m above the nozzles. Allowing 8% for friction loss in the pipe, calculate the following:
- Speed in rpm
  - Diameter of the jet
  - Mean diameter of the bucket
- Assume  $C_v = 0.98$ , speed ratio = 0.46, and overall efficiency = 85% (10 marks)
- (b) Define the terms unit power, unit speed, and unit discharge with reference to a hydraulic turbine. (4 marks)
18. (a) Show that the force exerted by a fluid jet in its direction of flow on a semicircular vane is twice that exerted on a flat plate, both plates being fixed in position. (7 marks)
- (b) A Kaplan turbine runner is to be designed to develop 9000 kW. The net available head is 5.5m. Assume a speed ratio 2, flow ratio 0.65, and total efficiency 85%. The diameter of the boss is 1/3 the diameter of the runner. Find :
- Diameter of the runner.
  - Speed of the runner.
  - Specific speed of the turbine.

### MODULE-V

19. (a) Draw the performance curves of a centrifugal pump. Also discuss the effect of blade outlet angles (7 marks)

- (b) A centrifugal pump discharges  $0.2 \text{ m}^3/\text{s}$  of water at a head of 25 m when running at a speed of 1400 rpm. The manometric efficiency is 80%. If the impeller has an outer diameter of 30 cm and width of 5 cm, determine the vane angle at the outlet. (7 marks)
20. (a) A single acting reciprocating pump of 200 mm bore and 300 mm stroke runs at 30 rpm. The suction head is 4 m and the delivery head is 15 m. Considering acceleration determine the pressure in the cylinder at the beginning and end of suction and delivery strokes. Take the value of atmospheric pressure as 10.3 m of water head. The length of suction pipe is 8 m and that of delivery pipe is 20 m. The pipe diameters are 120 mm each (7 marks)
- (b) The construction details of a centrifugal pump is as follows; Impeller diameter= 50 cm Impeller width=2.5 cm Speed= 1200 rpm Suction head= 6 m Delivery head= 40 m Outlet blade angle=  $30^\circ$ . Manometric efficiency : 80% Overall efficiency :75%. Determine the power required to drive the pump. Also calculate the pressures at the suction and delivery side of the pump. assume the frictional drop in suction is 2 m and in the delivery 8m and inlet swirl as zero (7 marks)





## ASSESSMENT PATTERN

Bloom's taxonomy	Continuous Assessment Tests		End Semester Examination (Marks)
	Test I (Marks)	Test II (Marks)	
Remember	25	25	25
Understand	15	15	15
Apply	30	25	30
Analyze	10	10	10
Evaluate	10	15	10
Create	10	10	10

### Mark distribution

Total Marks	CIE marks	ESE marks	ESE duration
150	50	100	3 Hours

### Continuous Internal Evaluation (CIE) Pattern:

Attendance	10 marks
Regular class work/tutorials/assignments	15 marks
Continuous Assessment Test (Minimum 2 numbers)	25 marks

**End semester pattern:-** There will be two parts; Part A and Part B. Part A contain 10 questions with 2 questions from each module, having 3 marks for each question. Students should answer all questions. Part B contains 2 questions from each module of which student should answer any one. Each question can have maximum 2 sub-divisions and carry 14 marks.

### Course Level Assessment Questions

**Course Outcome 1 (CO1):** Understand the basic chemical bonds, crystal structures and their relationship with the properties.

1. Why ionic and covalent bonded materials are poor conductors? Draw electronic configurations.
2. Correlate the strength of an element with atomic number.
3. What kind of bonding you expect in the following materials: NaCl, Cadmium Telluride and Bronze.
4. Explain how grain size influences the strength of a metal

**Course Outcome 2 (CO2):** How to quantify failure of materials.

1. Explain the factors affecting the fatigue strength?
2. Explain the effects of crystalline and non-crystalline structure on strength of a metal.
3. What are the roles of surface defects on crack propagation?
4. A small hole is drilled through a steel plate ahead of a crack, whether it can stop the crack's progress until repairs can be made or not? Explain in detail and derive the equation
5. Explain the effect of impact loading on ductile materials

**Course Outcome 3 (CO3):** Given a hypothetical or real problem with an electronic materials device or process, explain the cause of the problem and propose solutions.

1. Explain why nichrome and not copper is used as a heating element.
2. Why does the conductivity of a semiconductor change with impurity content? Compare this with the behavior of metallic conductors.
3. Explain why lead and zinc with an even number of electrons in the outer shell and a full valence band are conductors.
4. When ice melts into water, the dielectric constant increases, in contrast to the decrease observed during the melting of HCl. Explain why this is so.

**Course Outcome 4 (CO4):** Understand how materials interact at the nanoscale

1. What is the concept of nano? Correlate the significance of dislocation density to single crystal silicon ICs used in electronic industry.
2. Explain touch screens
3. Explain flexible electronic circuits

**Course Outcome 5 (CO5):** Define and differentiate engineering materials on the basis of structure and properties for engineering applications

1. Explain the slip systems of BCC, FCC and HCP. Why BCC and HCP exhibit brittle nature and FCC ductile nature?
2. Explain in detail the different strengthening mechanisms of metallic crystals
3. Explain why Aluminum used in long distance transmission lines cannot be strengthened by solid solution.
4. Explain the attributes of surface breakdown of an insulator

## **SYLLABUS**

### **MODULE - 1**

Earlier and present development of atomic structure- primary bonds: - secondary bonds - earlier and present development of atomic structure- primary bonds: - secondary bonds - classification of engineering materials- levels of structure- crystallography- structure–property relationships in materials - classification of engineering materials.

### **MODULE - II**

Miller indices: - modes of plastic deformation - structure determination by X-ray diffraction - Classification of crystal imperfections- Diffusion in solids, fick's laws - dislocation density - mechanism of crystallization: homogeneous and heterogeneous nuclei formation - Hall - Petch theory.

### **MODULE - III**

Phase diagrams: - Limitations of pure metals and need of alloying - classification of alloys, solid solutions, Hume Rothery's rule - strengthening mechanisms- Fatigue: - Stress cycles – fatigue tests, S-N curve - Ductile to brittle transition temperature (DBTT) in steels - Creep: Creep curves – creep tests - Super plasticity - introduction to super alloys.

### **MODULE - IV**

Composites:- fiber and composite phase - polymer matrix composites - metal matrix composites - ceramic matrix composites - dielectric materials- conductors - resistor materials.

### **MODULE - V**

Superconducting phenomenon - semi conductors- fabrication of integrated circuits - semiconductor devices.

### **Text Books**

1. Callister William. D., Material Science and Engineering, John Wiley, 2014
2. Raghavan V, Material Science and Engineering, Prentice Hall, 2004

### **Reference**

1. Avner H Sidney, Introduction to Physical Metallurgy, Tata McGraw Hill, 2009
2. Anderson J.C. *et.al.*, Material Science for Engineers, Chapman and Hall, 1990
3. Dieter George E, Mechanical Metallurgy, Tata McGraw Hill, 1976

## MODEL QUESTION PAPER

### MATERIAL SCIENCE & TECHNOLOGY - MET 285

Max. Marks : 100

Duration : 3 Hours

#### Part – A

Answer all questions.

Answer all questions, each question carries 3 marks

1. NASA's *Parker Solar Probe* will be the first-ever mission to "touch" the Sun. The spacecraft, about the size of a small car, will travel directly into the Sun's atmosphere about 4 million miles from the earth surface. Postulate the coolant used in the parker solar probe with chemical bonds.
2. Distinguish between crystal and non crystalline materials.
3. What is the driving force for diffusion?
4. What are the roles of surface imperfections on crack initiation?
5. What is the grain size preferred for creep applications? Why
6. Explain the attributes of DBTT
7. Make a list of at least four different sports implements that are made of or contain composites
8. What is the distinction between matrix and dispersed phases in a composite material?
9. Specify three elements that you would add to pure silicon to make it an extrinsic semiconductor of (i) the *n*-type, and (ii) the *p*-type.
10. Explain why nichrome and not copper is used as a heating element

#### PART -B

Answer one full question from each module.

##### Module -1

11. Calculate the APF of SC, BCC and FCC (14 marks).

OR

12. Distinguish between characteristics of ionic, covalent and metallic bonds (14 marks).

##### Module -2

13. Explain the effect of: (i) Grain size; (ii) Grain size distribution and (iii) Grain orientation (iv) Grain shape on strength and creep resistance with neat sketches. Attributes of Hall-Petch equation and grain boundaries (14 marks).

OR

14. Distinguish between homogeneous and heterogeneous nuclei formation (14 marks).

##### Module -3

15. Postulate with neat sketches, why 100 % pure metals are weaker? What are the primary functions of alloying? Explain the fundamental rules governing the alloying with neat sketches and how is it accomplished in substitution and interstitial solid solutions? (14 marks).

OR

16. Explain fatigue test and attributes of S-N curve (14 marks).

**Module -4**

17. For a polymer-matrix fiber-reinforced composite, (a) list three functions of the matrix phase; (b) Compare the desired mechanical characteristics of matrix and fiber phases; and (c) cite two reasons why there must be a strong bond between fiber and matrix at their interface (14 marks).

**OR**

18. The dielectric constant of polyethylene is independent of temperature, while that of polyvinylchloride is not. Explain this difference in behavior on the basis of their monomer structures (14 marks).

**Module -5**

19. (a) Derive the kinetic energy of free electrons as a function of their wave number (7 marks).  
 (b) The resistivity of silver at room temperature is  $1.6 \times 10^{-8}$  ohm m. Calculate the collision Time for electron scattering (7 marks).

**OR**

20. (a). Explain why lead and zinc with an even number of electrons in the outer shell and a full valence band are conductors (7 marks).  
 (b). Calculate the fraction of holes present at 300 K in silicon doped with indium. The acceptor level is 0.16 eV above the top of the valence band (7 marks).

**Course content and lecture schedules.**

Module	TOPIC	No. of hours	Course outcomes
1.1	Earlier and present development of atomic structure; correlation of atomic radius to strength; electron configurations; - Primary bonds: - characteristics of covalent, ionic and metallic bond - properties from bonding.	2	CO1
1.2	Secondary bonds: - classification- hydrogen bond and anomalous behavior of ice float on water, application- specific heat, applications.	2	
1.3	Classification of engineering materials- levels of structure- crystallography:- crystal, space lattice, unit cell- APF of BCC, FCC, HCP structures.	2	
1.4	short and long range order - non crystalline - structure–property relationships in materials.	1	
2.1	Miller indices: - crystal plane and direction - attributes of miller indices for slip system, brittleness of BCC, HCP and ductility of FCC - modes of plastic deformation: - slip and twinning - structure determination by X-ray diffraction.	3	CO1 CO2
2.2	Classification of crystal imperfections: - types of point and dislocations.- Diffusion in solids, fick’s laws, mechanisms, applications - dislocation density and attributes of nano structures.	3	

2.3	Mechanism of crystallization: Homogeneous and heterogeneous nuclei formation, under cooling, dendritic growth, grain boundary irregularity.	1	CO1
2.4	Effects of grain size, grain size distribution, grain shape, grain orientation on dislocation/strength and creep resistance - Hall - Petch theory.	2	CO2
3.1	Phase diagrams: - Limitations of pure metals and need of alloying - classification of alloys, solid solutions, Hume Rothery's rule - strengthening mechanisms.	3	CO2 CO5
3.2	Fatigue: - Stress cycles – Primary and secondary stress raisers - Characteristics of fatigue failure, fatigue tests, S-N curve attributes.	2	
3.3	Factors affecting fatigue strength: stress concentration, size effect, surface roughness, change in surface properties, surface residual stress - Ways to improve fatigue life.	2	
3.4	Ductile to brittle transition temperature (DBTT) in steels -Creep: Creep curves – creep tests - Super plasticity - introduction to nickel based super alloys, characteristics and applications.	2	
4.1	Composites:- fiber and composite phase - polymer matrix composites - metal matrix composites - ceramic matrix composites	2	CO1 CO2
4.2	Dielectric materials:- polarization, temperature and frequency effects, electric breakdown, ferroelectric materials.	3	CO1 CO2
4.3	Conductors: - the resistivity range, free electron theory.	2	CO1 CO2
4.4	Conduction by free electrons, conductor and resistor materials.	2	
5.1	Superconducting phenomenon, Type I and Type II superconductors, potential applications.	3	CO3
5.2	Semi conductors:- energy gap in solids, intrinsic and extrinsic semiconductors, semiconductor materials.	2	
5.3	Fabrication of integrated circuits: - production of metallurgical grade silicon, semiconductor grade silicon, single crystal growth, wafer manufacture, oxidation, photolithography, doping.	3	CO4
5.4	Ion implantation, epitaxial growth, metallization.	1	
5.5	Some semiconductor devices: - junction diodes, lasers and transistor, photon detectors.	2	CO4

# **SEMESTER -4**

COURSE CODE	COURSE NAME	CATEGORY	L	T	P	CREDITS
22MAT401	PROBABILITY, STATISTICS AND NUMERICAL METHODS	BS	3	1	0	4

**Preamble:** This course introduces students to the modern theory of probability and statistics, covering important models of random variables and techniques of parameter estimation and hypothesis testing. A brief course in numerical methods familiarises students with some basic numerical techniques for finding roots of equations, evaluating definite integrals solving systems of linear equations, and solving ordinary differential equations which are especially useful when analytical solutions are hard to find.

**Prerequisite:** A basic course in one-variable and multi-variable calculus.

**Course Outcomes:** After the completion of the course the student will be able to

<b>CO 1</b>	Understand the concept, properties and important models of discrete random variables and,using them, analyse suitable random phenomena.
<b>CO 2</b>	Understand the concept, properties and important models of continuous random variables and,using them, analyse suitable random phenomena.
<b>CO 3</b>	Perform statistical inferences concerning characteristics of a population based on attributes of samples drawn from the population
<b>CO 4</b>	Compute roots of equations, evaluate definite integrals and perform interpolation on given numerical data using standard numerical techniques
<b>CO 5</b>	Apply standard numerical techniques for solving systems of equations, fitting curves on given numerical data and solving ordinary differential equations.

### Mapping of course outcomes with program outcomes

	PO 1	PO 2	PO 3	PO 4	PO 5	PO 6	PO 7	PO 8	PO 9	PO 10	PO 11	PO 12
CO 1	3	2	2	2	2					2		1
CO 2	3	2	2	2	2					2		1
CO 3	3	2	2	2	2					2		1
CO 4	3	2	2	2	2					2		1
CO 5	3	2	2	2	2					2		1



### Assessment Pattern

Bloom's Category	Continuous Assessment Tests(%)		End Semester Examination(%)
	1	2	
Remember	10	10	10
Understand	30	30	30
Apply	30	30	30
Analyse	20	20	20
Evaluate	10	10	10
Create			

**End Semester Examination Pattern:** There will be two parts; Part A and Part B. Part A contain 10 questions with 2 questions from each module, having 3 marks for each question. Students should answer all questions. Part B contains 2 questions from each module of which student should answer any one. Each question can have maximum 2 sub-divisions and carry 14 marks.

### Course Level Assessment Questions

#### Course Outcome 1 (CO1):

1. Let  $X$  denote the number that shows up when an unfair die is tossed. Faces 1 to 5 of the die are equally likely, while face 6 is twice as likely as any other. Find the probability distribution, mean and variance of  $X$ .
2. An equipment consists of 5 components each of which may fail independently with probability 0.15. If the equipment is able to function properly when at least 3 of the components are operational, what is the probability that it functions properly?
3.  $X$  is a binomial random variable  $B(n, p)$  with  $n = 100$  and  $p = 0.1$ . How would you approximate it by a Poisson random variable?
4. Three balls are drawn at random without replacement from a box containing 2 white, 3 red and 4 black balls. If  $X$  denotes the number of white balls drawn and  $Y$  denotes the number of red balls drawn, find the joint probability distribution of  $(X, Y)$

#### Course Outcome 2 (CO2)

1. What can you say about  $P(X = a)$  for any real number  $a$  when  $X$  is a (i) discrete random variable? (ii) continuous random variable?

2. A string, 1 meter long, is cut into two pieces at a random point between its ends. What is the probability that the length of one piece is at least twice the length of the other?
3. A random variable has a normal distribution with standard deviation 10. If the probability that it will take on a value less than 82.5 is 0.82, what is the probability that it will take on a value more than 58.3?
4.  $X$  and  $Y$  are independent random variables with  $X$  following an exponential distribution with parameter  $\mu$  and  $Y$  following an exponential distribution with parameter  $\lambda$ . Find  $P(X + Y \leq 1)$

**Course Outcome 3(CO3):**

1. In a random sample of 500 people selected from the population of a city 60 were found to be left-handed. Find a 95% confidence interval for the proportion of left-handed people in the city population.
2. What are the types of errors involved in statistical hypothesis testing. Explain the level of risks associated with each type of error.
3. A soft drink maker claims that a majority of adults prefer its leading beverage over that of its main competitor's. To test this claim 500 randomly selected people were given the two beverages in random order to taste. Among them, 270 preferred the soft drink maker's brand, 211 preferred the competitor's brand, and 19 could not make up their minds. Determine whether there is sufficient evidence, at the 5% level of significance, to support the soft drink maker's claim against the default that the population is evenly split in its preference.
4. A nutritionist is interested in whether two proposed diets, *diet A* and *diet B* work equally well in providing weight-loss for customers. In order to assess a difference between the two diets, she puts 50 customers on diet A and 60 other customers on diet B for two weeks. Those on the former had weight losses with an average of 11 pounds and a standard deviation of 3 pounds, while those on the latter lost an average of 8 pounds with a standard deviation of 2 pounds. Do the diets differ in terms of their weight loss?

**Course Outcome 4(CO4):**

1. Use Newton-Raphson method to find a real root of the equation  $f(x) = e^{2x} - x - 6$  correct to 4 decimal places.
2. Compare Newton's divided difference method and Lagrange's method of interpolation.

3. Use Newton's forward interpolation formula to compute the approximate values of the function  $f$  at  $x = 0.25$  from the following table of values of  $x$  and  $f(x)$

$x$	0	0.5	1	1.5	2
$f(x)$	1.0000	1.0513	1.1052	1.1618	1.2214

4. Find a polynomial of degree 3 or less the graph of which passes through the points  $(-1,3)$ ,  $(0,-4)$ ,  $(1,5)$  and  $(2,-6)$

### Course Outcome 5 (CO5):

1. Apply Gauss-Seidel method to solve the following system of equations

$$\begin{aligned} 4x_1 - x_2 - x_3 &= 3 \\ -2x_1 + 6x_2 + x_3 &= 9 \\ -x_1 + x_2 + 7x_3 &= -6 \end{aligned}$$

2. Using the method of least squares fit a straight line of the form  $y = ax + b$  to the following set of ordered pairs  $(x, y)$  :  
 $(2,4)$ ,  $(3,5)$ ,  $(5,7)$ ,  $(7,10)$ ,  $(9,15)$
3. Write the normal equations for fitting a curve of the form  $y = a_0 + a_1x^2$  to a given set of pairs of data points.
4. Use Runge-Kutta method of fourth order to compute  $y(0.25)$  and  $y(0.5)$ , given the initial value problem  
 $y' = x + xy + y, y(0) = 1$

## Syllabus

### Module 1 (Discrete probability distributions)

9 hours

(Text-1: *Relevant topics* from sections-3.1-3.4, 3.6, 5.1)

Discrete random variables and their probability distributions, Expectation, mean and variance, Binomial distribution, Poisson distribution, Poisson approximation to the binomial distribution, Discrete bivariate distributions, marginal distributions, Independent random variables, Expectation -multiple random variables.

### Module 2 (Continuous probability distributions)

9 hours

(Text-1: *Relevant topics* from sections-4.1-4.4, 3.6, 5.1)

Continuous random variables and their probability distributions, Expectation, mean and variance, Uniform, exponential and normal distributions, Continuous bivariate distributions, marginal distributions, Independent random variables, Expectation-multiple random variables, i.i.d random variables and Central limit theorem (**without proof**).

**Module 3 (Statistical inference)**

**9 hours**

**(Text-1: Relevant topics from sections-5.4,, 3.6, 5.1,7.2, 8.1, 8.3, 9.1-9.2,9.4)**

Population and samples, Sampling distribution of the mean and proportion (for large samples only), Confidence interval for single mean and single proportions(for large samples only). Test of hypotheses: Large sample test for single mean and single proportion, equality of means and equality of proportions of two populations, small sample t-tests for single mean of normal population, equality of means (**only pooled t-test, for independent samples from two normal populations with equal variance** )

**Module 4 (Numerical methods -I)**

**9 hours**

**(Text 2- Relevant topics from sections 19.1, 19.2, 19.3, 19.5)**

Errors in numerical computation-round-off, truncation and relative error, Solution of equations – Newton-Raphson method and Regula-Falsi method. Interpolation-finite differences, Newton's forward and backward difference method, Newton's divided difference method and Lagrange's method. Numerical integration-Trapezoidal rule and Simpson's 1/3rd rule (**Proof or derivation of the formulae not required for any of the methods in this module**)

**Module 5 (Numerical methods -II)**

**9 hours**

**(Text 2- Relevant topics from sections 20.3, 20.5, 21.1)**

Solution of linear systems-Gauss-Siedal and Jacobi iteration methods. Curve fitting-method of least squares, fitting straight lines and parabolas. Solution of ordinary differential equations-Euler and Classical Runge-Kutta method of second and fourth order, Adams-Moulton predictor-correction method (**Proof or derivation of the formulae not required for any of the methods in this module**)

**Text Books**

1. (Text-1) Jay L. Devore, *Probability and Statistics for Engineering and the Sciences*, 8<sup>th</sup> edition, Cengage, 2012
2. (Text-2) Erwin Kreyszig, *Advanced Engineering Mathematics*, 10 th Edition, John Wiley & Sons, 2016.

**Reference Books**

1. Hossein Pishro-Nik, *Introduction to Probability, Statistics and Random Processes*, Kappa Research, 2014 ( Also available online at [www.probabilitycourse.com](http://www.probabilitycourse.com) )
2. Sheldon M. Ross, *Introduction to probability and statistics for engineers and*

- scientists*, 4<sup>th</sup> edition, Elsevier, 2009.
3. T. Veera Rajan, *Probability, Statistics and Random processes*, Tata McGraw-Hill, 2008
  4. B.S. Grewal, *Higher Engineering Mathematics*, Khanna Publishers, 36 Edition, 2010.

### Assignments

Assignments should include specific problems highlighting the applications of the methods introduced in this course in physical sciences and engineering.

### Course Contents and Lecture Schedule

No	Topic	No. of Lectures
<b>1</b>	<b>Discrete Probability distributions</b>	<b>9 hours</b>
1.1	Discrete random variables and probability distributions, expected value, mean and variance (discrete)	3
1.2	Binomial distribution-mean, variance, Poisson distribution-mean, variance, Poisson approximation to binomial	3
1.3	Discrete bivariate distributions, marginal distributions, Independence of random variables (discrete), Expected values	3
<b>2</b>	<b>Continuous Probability distributions</b>	<b>9 hours</b>
2.1	Continuous random variables and probability distributions, expected value, mean and variance (continuous)	2
2.2	Uniform, exponential and normal distributions, mean and variance of these distributions	4
2.3	Continuous bivariate distributions, marginal distributions, Independent random variables, Expected values, Central limit theorem.	3
<b>3</b>	<b>Statistical inference</b>	<b>9 hours</b>
3.1	Population and samples, Sampling distribution of single mean and single proportion( large samples)	1
3.2	Confidence interval for single mean and single proportions ( large samples)	2
3.3	Hypothesis testing basics, large sample test for single proportion, single proportion	2
3.4	Large sample test for equality of means and equality of proportions of two populations	2

3.5	t-distribution and small sample t-test for single mean and pooled t-test for equality of means	2
<b>4</b>	<b>Numerical methods-I</b>	<b>9 hours</b>
4.1	Roots of equations- Newton-Raphson, regulafalsi methods	2
4.2	Interpolation-finite differences, Newton's forward and backward formula,	3
4.3	Newton's divided difference method, Lagrange's method	2
4.3	Numerical integration-trapezoidal rule and Simpson's 1/3-rd rule	2
<b>5</b>	<b>Numerical methods-II</b>	<b>9 hours</b>
5.1	Solution of linear systems-Gauss-Siedal method, Jacobi iteration method	2
5.2	Curve-fitting-fitting straight lines and parabolas to pairs of data points using method of least squares	2
5.3	Solution of ODE-Euler and Classical Runge-Kutta methods of second and fourth order	4
5.4	Adams-Moulton predictor-corrector methods	1

**Model Question Paper**  
**(2019 Scheme)**

Reg No: .....  
Name: .....

Total Pages: 4

FOURTH SEMESTER B.TECH DEGREE EXAMINATION  
(Month & year)  
**Course Code: MAT**

**Course Name: PROBABILITY, STATISTICS AND NUMERICAL METHODS**  
(Common to all branches except (i) Electrical and Electronics, (ii) Electronics and Communication, (iii) Applied Electronics and Instrumentation (iv) Computer Science and Engineering (v) Information Technology )

Max Marks :100

Duration : 3 Hours

**PART A**

(Answer *all* questions. Each question carries 3 marks)

1. Suppose  $X$  is binomial random variable with parameters  $n = 100$  and  $p = 0.02$ . Find  $P(X < 3)$  using Poisson approximation to  $X$ . (3)
2. The diameter of circular metallic discs produced by a machine is a random variable with mean 6cm and variance 2cm. Find the mean area of the discs. (3)
3. Find the mean and variance of the continuous random variable  $X$  with probability density function (3)  
$$f(x) = \begin{cases} 2x - 4, & 2 \leq x \leq 3 \\ 0 & \text{otherwise} \end{cases}$$
4. The random variable  $X$  is exponentially distributed with mean 3. Find  $P(X > t + 3|X > t)$  where  $t$  is any positive real number. (3)
5. The 95% confidence interval for the mean mass (in grams) of tablets produced by a machine is [0.56 0.57], as calculated from a random sample of 50 tablets. What do you understand from this statement? (3)
6. The mean volume of liquid in bottles of lemonade should be at least 2 litres. A sample of bottles is taken in order to test whether the mean volume has fallen below 2 litres. Give a null and alternate hypothesis for this test and specify whether the test would be one-tailed or two-tailed. (3)
7. Find all the first and second order forward and backward differences of  $y$  for the following set of  $(x, y)$  values: (0.5, 1.13), (0.6, 1.19), (0.7, 1.26), (0.8, 1.34) (3)
8. The following table gives the values of a function  $f(x)$  for certain values of  $x$ . (3)

$x$	0	0.25	0.50	0.75	1
$f(x)$	1	0.9412	0.8	0.64	0.5

Evaluate  $\int_0^1 f(x)dx$  using trapezoidal rule.

9. Explain the principle of least squares for determining a line of best fit to a given data (3)
10. Given the initial value problem  $y' = y + x$ ,  $y(0) = 0$ , find  $y(0.1)$  and  $y(0.2)$  using Euler method. (3)

**PART B**  
**(Answer one question from each module)**

**MODULE 1**

11. (a) The probability mass function of a discrete random variable is  $p(x) = kx$ ,  $x = 1, 2, 3$  where  $k$  is a positive constant. Find (i) the value of  $k$  (ii)  $P(X \leq 2)$  (iii)  $E[X]$  and (iv)  $\text{var}(1 - X)$ . (7)
- (b) Find the mean and variance of a binomial random variable (7)

**OR**

12. (a) Accidents occur at an intersection at a Poisson rate of 2 per day. What is the probability that there would be no accidents on a given day? What is the probability that in January there are at least 3 days (not necessarily consecutive) without any accidents? (7)
- (b) Two fair dice are rolled. Let  $X$  denote the number on the first die and  $Y = 0$  or  $1$ , according as the first die shows an even number or odd number. Find (i) the joint probability distribution of  $X$  and  $Y$ , (ii) the marginal distributions. (iii) Are  $X$  and  $Y$  independent? (7)

**MODULE 2**

13. (a) The IQ of an individual randomly selected from a population is a normal distribution with mean 100 and standard deviation 15. Find the probability that an individual has IQ (i) above 140 (ii) between 120 and 130. (7)
- (b) A continuous random variable  $X$  is uniformly distributed with mean 1 and variance  $4/3$ . Find  $P(X < 0)$  (7)

**OR**

14. (a) The joint density function of random variables  $X$  and  $Y$  is given by (7)

$$f(x, y) = \begin{cases} e^{-(x+y)}, & x > 0, \quad y > 0 \\ 0 & \text{otherwise.} \end{cases}$$

Find  $P(X + Y \leq 1)$ . Are  $X$  and  $Y$  independent? Justify.

- (b) The lifetime of a certain type of electric bulb may be considered as an exponential random variable with mean 50 hours. Using central limit theorem, find the approximate probability that 100 of these electric bulbs will provide a total of more than 6000 hours of burning time. (7)

**MODULE 3**

15. (a) The mean blood pressure of 100 randomly selected persons from a target population is 127.3 units. Find a 95% confidence interval for the mean blood pressure of the population. (7)
- (b) The CEO of a large electric utility claims that 80 percent of his 1,000,000 customers are very satisfied with the service they receive. To test this claim, the local newspaper surveyed 100 customers, using simple random sampling. Among the sampled customers, 73 percent say they are very satisfied. Based on these findings, do you think that the CEO is making a false claim of high satisfaction levels among his customers? Use a 0.05 level of significance. (7)

**OR**



16. (a) A magazine reported the results of a telephone poll of 800 adult citizens of a country. The question posed was: "Should the tax on cigarettes be raised to pay for health care reform?" The results of the survey were: Out of the 800 persons surveyed, 605 were non-smokers out of which 351 answered "yes" and the rest "no". Out of the remaining 195, who were smokers, 41 answered "yes" and the remaining "no". Is there sufficient evidence, at the 0.05 significance level, to conclude that the two populations smokers and non-smokers differ significantly with respect to their opinions? (7)
- (b) Two types of cars are compared for acceleration rate. 40 test runs are recorded for each car and the results for the mean elapsed time recorded below: (7)

	Sample mean	Sample standard deviation
Car A	7.4	1.5
Car B	7.1	1.8

determine if there is a difference in the mean elapsed times of the two car models at 95% confidence level.

#### MODULE 4

17. (a) Use Newton-Raphson method to find a non-zero solution of  $x = 2 \sin x$ . Start with  $x_0 = 1$  (7)
- (b) Using Lagrange's interpolating polynomial estimate  $f(1.5)$  for the following data (7)

$x$	0	1	2	3
$y = f(x)$	0	0.9826	0.6299	0.5532

OR

18. (a) Consider the data given in the following table (7)

$x$	0	0.5	1	1.5	2
$f(x)$	1.0000	1.0513	1.1052	1.1618	1.2214

Estimate the value of  $f(1.80)$  using Newton's backward interpolation formula.

- (b) Evaluate  $\int_0^1 e^{-x^2/2} dx$  using Simpson's one-third rule, dividing the interval  $[0, 1]$  into 8 subintervals (7)

#### MODULE 5

19. (a) Using Gauss-Seidel method, solve the following system of equations (7)

$$\begin{aligned} 20x + y - 2z &= 17 \\ 3x + 20y - z &= -18 \\ 2x - 3y + 20z &= 25 \end{aligned}$$

- (b) The table below gives the estimated population of a country (in millions) for during 1980-1995 (7)

year	1980	1985	1990	1995
population	227	237	249	262

Plot a graph of this data and fit an appropriate curve to the data using the method of least squares. Hence predict the population for the year 2010.

OR

20. (a) Use Runge-Kutta method of fourth order to find  $y(0.2)$  given the initial value problem (7)

$$\frac{dy}{dx} = \frac{xy}{1+x^2}, \quad y(0) = 1$$

Take step-size,  $h = 0.1$ .

- (b) Solve the initial value problem (7)

$$\frac{dy}{dx} = x + y, \quad y(0) = 0,$$

in the interval  $0 \leq x \leq 1$ , taking step-size  $h = 0.2$ . Calculate  $y(0.2)$ ,  $y(0.4)$  and  $y(0.6)$  using Runge-Kutta second order method, and  $y(0.8)$  and  $y(1.0)$  using Adam-Moulton predictor-corrector method.

\*\*\*\*

COURSE CODE	COURSE NAME	CATEGORY	L	T	P	CREDITS
22MET402	ENGINEERING THERMODYNAMICS	ES	3	1	0	4

**Preamble :**

Thermodynamics is the study of energy . Without energy life cannot exist. Activities from breathing to the launching of rockets involves energy transactions and are subject to thermodynamic analysis. Engineering devices like engines, turbines, refrigeration and air conditioning systems, propulsion systems etc., work on energy transformations and must be analysed using principles of thermodynamics. So, a thorough knowledge of thermodynamic concepts is essential for a mechanical engineer. This course offers an introduction to the basic concepts and laws of thermodynamics.

**Prerequisite :** NIL

**Course Outcomes :**

After completion of the course the student will be able to

CO1	Understand basic concepts and laws of thermodynamics
CO2	Conduct first law analysis of open and closed systems
CO3	Determine entropy and availability changes associated with different processes
CO4	Understand the application and limitations of different equations of state
CO5	Determine change in properties of pure substances during phase change processes
CO6	Evaluate properties of ideal gas mixtures

**Mapping of course outcomes with program outcomes**

	PO1	PO2	PO3	PO4	PO5	PO6	PO7	PO8	PO9	PO10	PO11	PO12
CO1	2	2										2
CO2	2	2	1	1								1
CO3	3	3	2	2								1
CO4	2	2	2	2								1
CO5	3	3	2	1								1
CO6	3	3	2	2								1

**Assessment Pattern**

Blooms Category	CA			ESA
	Assignment	Test - 1	Test - 2	
Remember	25	20	20	10
Understand	25	40	40	20
Apply	25	40	40	70
Analyse	25			
Evaluate				
Create				

**Continuous Internal Evaluation Pattern:**

Attendance : 10 marks

Continuous Assessment Test (2 numbers) : 25 marks

Assignment/Quiz/Course project : 15 marks

**Mark distribution & Duration of Examination :**

Total Marks	CA	ESE	ESE Duration
150	50	100	3 Hours

**End semester pattern:**

There will be two parts; Part A and Part B. Part A contain 10 questions with 2 questions from each module, having 3 marks for each question. Students should answer all questions. Part B contains 2 questions from each module of which student should answer any one. Each question can have maximum 2 sub-divisions and carry 14 marks.

**COURSE LEVEL ASSESSMENT QUESTIONS****Course Outcome 1**

1. Discuss the limitations of first law of thermodynamics.
2. Second law of thermodynamics is often called a directional law . Why?
3. Explain Joule-Kelvin effect. What is the significance of the inversion curve ?

**Course Outcome 2**

1. A mass of 2.4 kg of air at 150 kPa and 12°C is contained in a gas – tight, frictionless piston – cylinder device. The air is now compressed to a final pressure of 600 kPa . During this process, heat is transferred from the air such that the temperature inside the cylinder remains constant. Calculate the work input during this process.
2. Carbon dioxide enters an adiabatic nozzle steadily at 1 MPa and 500°C with a mass flow rate of 600 kg/hr and leaves at 100 kPa and 450 m/s. The inlet area of the nozzle is 40 cm<sup>2</sup>. Determine (a) the inlet velocity and (b) the exit temperature
3. A vertical piston – cylinder device initially contains 0.25 m<sup>3</sup> of air at 600 kPa and 300°C. A valve connected to the cylinder is now opened and air is allowed to escape until three-quarters of the mass leave the cylinder at which point the volume is 0.05 m<sup>3</sup>. Determine the final temperature in the cylinder and the boundary work during this process.

**Course Outcome 3**

1. An adiabatic vessel contains 2 kg of water at 25°C. By paddle – wheel work transfer, the temperature of water is increased to 30°C. If the specific heat of water is assumed to be constant at 4.186 kJ/kg.K, find the entropy change of the universe.

2. Two kilograms of water at 80°C is mixed adiabatically with 3 kg of water at 30°C in a constant pressure process at 1 atm. Find the increase in entropy of the total mass of water due to the mixing process.

3. Argon enters an insulated turbine operating under steady state at 1000°C and 2 MPa and exhausts at 350 kPa. The mass flow rate is 0.5 kg/s and the turbine develops power at the rate of 120 kW. Determine (a) the temperature of the argon at the turbine exit, (b) the irreversibility of the turbine and (c) the second law efficiency. Neglect KE and PE effects. Take  $T_o = 20^\circ\text{C}$  and  $P_o = 1 \text{ bar}$

#### Course Outcome 4

1. What are the limitations of ideal gas equation and how does Van der Waals equation overcome these limitations ?

2. Discuss law of corresponding states and its role in the construction of compressibility chart.

3. A rigid tank contains 2 kmol of  $\text{N}_2$  and 6 kmol of  $\text{CH}_4$  gases at 200 K and 12 MPa. Estimate the volume of the tank, using (a) ideal gas equation of state (b) the compressibility chart and Amagat's law

#### Course Outcome 5

1. Steam is throttled from 3 MPa and 600°C to 2.5 MPa. Determine the temperature of the steam at the end of the throttling process.

2. Determine the change in specific volume, specific enthalpy and quality of steam as saturated steam at 15 bar expands isentropically to 1 bar. Use steam tables

3. Estimate the enthalpy of vapourization of steam at 500 kPa, using the Clapeyron equation and compare it with the tabulated value

#### Course Outcome 6

1. A gaseous mixture contains, by volume, 21% nitrogen, 50% hydrogen and 29% carbon dioxide. Calculate the molecular weight of the mixture, the characteristic gas constant of the mixture and the value of the reversible adiabatic expansion index -  $\gamma$ . At 10°C, the  $C_p$  values of nitrogen, hydrogen and carbon dioxide are 1.039, 14.235 and 0.828 kJ/kg.K respectively.

2. A mixture of 2 kmol of  $\text{CO}_2$  and 3 kmol of air is contained in a tank at 199 kPa and 20°C. Treating air to be a mixture of 79%  $\text{N}_2$  and 21%  $\text{O}_2$  by volume, calculate (a) the individual mass of  $\text{CO}_2$ ,  $\text{N}_2$  and  $\text{O}_2$ , (b) the percentage content of carbon by mass in the mixture and (c) the molar mass, characteristic gas constant and the specific volume of the mixture

3. A gas mixture in an engine cylinder has 12%  $\text{CO}_2$ , 11.5%  $\text{O}_2$  and 76.5%  $\text{N}_2$  by volume. The mixture at 1000°C expands reversibly, according to the law  $PV^{1.25} = \text{constant}$ , to 7 times its initial volume. Determine the work transfer and heat transfer per unit mass of the mixture.

# SYLLABUS

**Module 1:** Role of Thermodynamics and its applications in Engineering and Science –Basic Concepts Macroscopic and Microscopic viewpoints, Concept of Continuum, Thermodynamic System and Control Volume, Surrounding, Boundaries, Types of Systems, Universe, Thermodynamic properties, Process, Cycle, Thermodynamic Equilibrium, Quasi – static Process, State, Point and Path function. Zeroth Law of Thermodynamics, Measurement of Temperature, reference Points, Temperature Scales.

**Module 2:** Energy - Work - Pdv work and other types of work transfer, free expansion work, heat and heat capacity. Joule's Experiment- First law of Thermodynamics - First law applied to Non flow Process- Enthalpy- specific heats- PMM1, First law applied to Flow Process, Mass and Energy balance in simple steady flow process. Applications of SFEE, Transient flow –Filling and Emptying Process, Limitations of the First Law.

**Module 3:** Second Law of Thermodynamics, Thermal Reservoir, Heat Engine, Heat pump – Kelvin-Planck and Clausius Statements, Equivalence of two statements, Reversibility, Irreversible Process, Causes of Irreversibility, PMM2, Carnot's theorem and its corollaries, Absolute Thermodynamic Temperature scale. Clausius Inequality, Entropy- Entropy changes in various thermodynamic processes, principle of increase of entropy and its applications, Entropy generation, Entropy and Disorder, Reversible adiabatic process- isentropic process, Third law of thermodynamics, Available Energy, Availability and Irreversibility- Second law efficiency.

**Module 4:** Pure Substances, Phase Transformations, Triple point, properties during change of phase, T-v, p-v and p-T diagram of pure substance, p-v-T surface, Saturation pressure and Temperature, T-h and T-s diagrams, h-s diagrams or Mollier Charts, Dryness Fraction, steam tables. Property calculations using steam tables. The ideal Gas Equation, Characteristic and Universal Gas constants, Deviations from ideal Gas Model: Equation of state of real substances, Vander Waals Equation of State, Virial Expansion, Compressibility factor, Law of corresponding state, Compressibility charts.

**Module 5:** Mixtures of ideal Gases – Mole Fraction, Mass fraction, Gravimetric and volumetric Analysis, Dalton's Law of partial pressure, Amagat's Laws of additive volumes, Gibbs-Dalton's law Equivalent Gas constant and Molecular Weight, Properties of gas mixtures: Internal Energy, Enthalpy, specific heats and Entropy, Introduction to real gas mixtures- Kay's rule. General Thermodynamic Relations – Combined First and Second law equations – Helmholtz and Gibb's functions - Maxwell's Relations, Tds Equations. The Clapeyron Equation, equations for internal energy, enthalpy and entropy, specific heats, Throttling process, Joule Thomson Coefficient, inversion curve.

## Text Books

1. P. K. Nag, Engineering Thermodynamics, McGraw Hill, 2013
2. E. Rathakrishnan Fundamentals of Engineering Thermodynamics, PHI, 2005
3. Y. A. Cengel and M. A. Boles, Thermodynamics an Engineering Approach, McGraw Hill, 2011

### Reference Books:

1. Moran J., Shapiro N. M., Fundamentals of Engineering Thermodynamics, Wiley, 2006
2. R. E. Sonntag and C. Borgnakke, Fundamentals of Thermodynamics, Wiley, 2009
3. Holman J. P. Thermodynamics, McGraw Hill, 2004
4. M. Achuthan, Engineering Thermodynamics, PHI, 2004

## COURSE PLAN

Module	Topics	Hours Allotted
1	Role of Thermodynamics and it's applications in Engineering and Science – Basic Concepts Macroscopic and Microscopic viewpoints, Concept of Continuum, Thermodynamic System and Control Volume, Surrounding, Boundaries, Types of Systems, Universe	1L
	Thermodynamic properties, Process, Cycle, Thermodynamic Equilibrium, Quasi – static Process, State, Point and Path function.	1L
	Zerth Law of Thermodynamics, Measurement of Temperature, reference Points, Temperature Scales.	2L + 1T
2	Energy - Work - Pdv work and other types of work transfer, free expansion work, heat and heat capacity.	2L + 1T
	Joule's Experiment- First law of Thermodynamics - First law applied to Non flow Process- Enthalpy- specific heats- PMM1	2L + 1T
	First law applied to Flow Process, Mass and Energy balance in simple steady flow process. Applications of SFEE	2L + 1T
	Transient flow –Filling and Emptying Process, Limitations of the First Law.	1L + 1T
3	Second Law of Thermodynamics, Thermal Reservoir, Heat Engine, Heat pump – Kelvin-Planck and Clausius Statements, Equivalence of two statements	2L
	Reversibility, Irreversible Process, Causes of Irreversibility, PMM2, Carnot's theorem and its corollaries, Absolute Thermodynamic Temperature scale.	2L + 1T
	Clausius Inequality, Entropy- Entropy changes in various thermodynamic processes, principle of increase of entropy and its applications, Entropy generation, Entropy and Disorder, Reversible adiabatic process- isentropic process, Third law of thermodynamics	2L + 1T
	Available Energy, Availability and Irreversibility- Second law efficiency.	2L + 1T
	Pure Substances, Phase Transformations, Triple point, properties during change of phase, T-v, p-v and p-T diagram of pure substance, p-v-T surface,	2L

4	Saturation pressure and Temperature, T-h and T-s diagrams, h-s diagrams or Mollier Charts, Dryness Fraction, steam tables. Property calculations using steam tables	2L + 1T
	The ideal Gas Equation, Characteristic and Universal Gas constants, Deviations from ideal Gas Model: Equation of state of real substances, Vander Waals Equation of State, Virial Expansion, Compressibility factor, Law of corresponding state, Compressibility charts.	2L +1T
5	Mixtures of ideal Gases – Mole Fraction, Mass fraction, Gravimetric and volumetric Analysis, Dalton’s Law of partial pressure, Amagat’s Laws of additive volumes, Gibbs-Dalton’s law.	2L
	Equivalent Gas constant and Molecular Weight, Properties of gas mixtures: Internal Energy, Enthalpy, specific heats and Entropy	1L +1T
	Introduction to real gas mixtures- Kay’s rule	1L
	General Thermodynamic Relations – Combined First and Second law equations – Helmholtz and Gibb’s functions - Maxwell’s Relations	2L
	Tds Equations. The Clapeyron Equation, equations for internal energy, enthalpy and entropy, specific heats, Throttling process, Joule Thomson Coefficient, inversion curve.	2L + 1T



**MODEL QUESTION PAPER**  
**FOURTH SEMESTER B.TECH DEGREE**  
**EXAMINATION Course Code : MET202**  
**Course Name : ENGINEERING THERMODYNAMICS**  
( Permitted to use Steam Tables and Mollier Chart )

Max. Marks : 100

Duration : 3 Hours

**Part – A**

Answer all questions.

1. Define thermodynamics. List a few of its applications
2. Differentiate between intensive and extensive properties.
3. Differentiate between heat and work.
4. Explain system approach and control volume approach as applied in the analysis of a flow process.
5. An inventor claims to have developed an engine that delivers 26 kJ of work using 82 kJ of heat while operating between temperatures 120°C and 30°C. Is his claim valid ? Give the reason for your answer.
6. Show that two reversible adiabatics cannot intersect
7. Define (i) critical point and (ii) triple point, with respect to water
8. Why do real gases deviate from ideal gas behaviour? When do they approach ideal behaviour?
9. Define Helmholtz function and Gibbs function and state their significance
10. Explain Kay's rule of real gas mixtures

( 3 x 10 = 30 marks )

**Part – B**

Answer one full question from each module.

**Module - 1**

- 11.a] Explain macroscopic and microscopic approach to thermodynamics .

( 7 marks )

b] With the aid of a suitable diagram, explain the working of constant volume gas thermometer. ( 7 marks )

OR

12.a] What is meant by thermodynamic equilibrium ? What are the essential conditions for a system to be in thermodynamic equilibrium ? ( 7 marks )

b] Express the temperature of  $91^{\circ}\text{C}$  in (i) Fahrenheit (ii) Kelvin (iii) Rankine. ( 7 marks )

### Module – 2

13.a] A mass of 2.4 kg of air at 150 kPa and  $12^{\circ}\text{C}$  is contained in a gas – tight, frictionless piston – cylinder device. The air is now compressed to a final pressure of 600 kPa . During this process, heat is transferred from the air such that the temperature inside the cylinder remains constant. Calculate the work input during this process. ( 7 marks )

b] A  $2\text{ m}^3$  rigid tank initially contains air at 100 kPa and  $22^{\circ}\text{C}$ . The tank is connected to a supply line through a valve. Air is flowing in the supply line at 600 kPa and  $22^{\circ}\text{C}$ . The valve is opened, and air is allowed to enter the tank until the pressure in the tank reaches the line pressure, at which point the valve is closed. A thermometer placed in the tank indicates that the air temperature at the final state is  $77^{\circ}\text{C}$ . Determine, (i) the mass of air that has entered the tank and (ii) the amount of heat transfer. ( 7 marks )

OR

14.a] A turbine operates under steady flow conditions, receiving steam at the following conditions : pressure 1.2 MPa, temperature  $188^{\circ}\text{C}$ , enthalpy 2785 kJ/kg, velocity 33.3 m/s and elevation 3m. The steam leaves the turbine at the following conditions : pressure 20 kPa, enthalpy 25kJ/kg, velocity 100 m/s, and elevation 0 m. Heat is lost to the surroundings at the rate of 0.29 kJ/s. If the rate of steam flow through the turbine is 0.42 kg/s, what is the power output of the turbine in kW ? ( 7 marks )

b] State the general energy balance equation for an unsteady flow system and from it, derive the energy balance equation for a bottle filling process, stating all assumptions. ( 7 marks )

### Module – 3

15.a] State the Kelvin-Planck and Clausius statements of the second law of thermodynamics and prove their equivalence. ( 7 marks )

b] A heat engine operating between two reservoirs at 1000 K and 300 K is used to drive a heat pump which extracts heat from the reservoir at 300 K at a rate twice that at which the engine rejects heat to it. If the efficiency of the engine is 40 % of the maximum possible and the COP of the heat pump is 50 % of the maximum possible, what is the temperature of the reservoir to which the heat pump rejects heat ? What is the rate of heat rejection from the heat pump, if the rate of heat supply to the engine is 50kW ? ( 7 marks )

OR

- 16.a] A house is to be maintained at 21°C during winter and at 26°C during summer. Heat leakage through the walls, windows and roof is about 3000 kJ/hr per degree temperature difference between the interior of the house and the environment. A reversible heat pump is proposed for realising the desired heating and cooling. What is the minimum power required to run the heat pump in the reverse, if the outside temperature during summer is 36°C? Also find the lowest environment temperature during winter for which the inside of the house can be maintained at 21°C consuming the same power. ( 7 marks )
- b] Air enters a compressor in steady flow at 140 kPa, 17°C and 70 m/s and leaves at 350 kPa, 127°C and 110 m/s. The environment is at 100 kPa and 7°C. Calculate per kg of air (a) the actual work required (b) the minimum work required and (c) the irreversibility of the process. ( 7 marks )

#### Module – 4

- 17.a] Show the constant pressure transformation of unit mass of ice at atmospheric pressure and -20°C to superheated steam at 220°C on P-v, T-v and P-T coordinate systems and explain their salient features. ( 7 marks )
- b] A rigid vessel of volume 0.3 m<sup>3</sup> contains 10 kg of oxygen at 300 K. Using (i) the perfect gas equation and (ii) the Van der Waal's equation of state, determine the pressure of oxygen in the vessel. Take the Van der Waal's constants for oxygen as  $a = 0.1382 \text{ m}^6 \text{ Pa} / \text{mol}^2$  and  $b = 0.03186 \text{ m}^3 / \text{kmol}$ . ( 7 marks )
- OR
- 18.a] Steam at 25 bar and 300°C expands isentropically to 5 bar. Calculate the change in enthalpy, volume and temperature of unit mass of steam during this process using steam tables and Mollier chart and compare the values ( 7 marks )
- b] Explain law of corresponding states and its significance to the generalized compressibility chart. ( 7 marks )

#### Module – 5

- 19.a] Derive the expressions for the equivalent molecular weight and characteristic gas constant for a mixture of ideal gases. ( 6 marks )
- b] 0.5 kg of Helium and 0.5 kg of Nitrogen are mixed at 20°C and at a total pressure of 100 kPa. Find (i) volume of the mixture (ii) partial volumes of the components (iii) partial pressures of the

components (iv) the specific heats of the mixture and (v) the gas constant of the mixture. Take ratio of specific heats for Helium and Nitrogen to be 1.667 and 1.4 respectively. ( 8 marks )

OR

20.a] 2 kg of carbon dioxide at 38°C and 1.4 bar is mixed with 5 kg of nitrogen at 150°C and 1.03 bar to form a mixture at a final pressure of 70 kPa. The process occurs adiabatically in a steady flow apparatus. Calculate the final temperature of the mixture and the change in entropy during the mixing process. Take specific heat at constant pressure for CO<sub>2</sub> and N<sub>2</sub> as 0.85 kJ/kg.K and 1.04 kJ/kg respectively. ( 7 marks )

b] Derive the Maxwell relations. Explain their significance ? ( 7 marks )



## Assessment Pattern

Bloom's taxonomy	Continuous Assessment Tests		End Semester Examination (Marks)
	Test I (Marks)	Test II (Marks)	
Remember	25	25	25
Understand	15	15	15
Apply	30	25	30
Analyse	10	10	10
Evaluate	10	15	10
Create	10	10	10

## Mark distribution

Total Marks	CIE marks	ESE marks	ESE duration
150	50	100	3 Hours

## Continuous Internal Evaluation (CIE) Pattern:

Attendance	10 marks
Regular class work/tutorials/assignments	15 marks
Continuous Assessment Test (Minimum 2 numbers)	25 marks

**End semester pattern:-** There will be two parts; Part A and Part B. Part A contain 10 questions with 2 questions from each module, having 3 marks for each question. Students should answer all questions. Part B contains 2 questions from each module of which student should answer any one. Each question can have maximum 2 subdivisions and carry 14 marks.

## COURSE LEVEL ASSESSMENT QUESTIONS

### Part -A

**Course Outcome 1 (CO1):** - Illustrate the basic principles of foundry practices and special casting processes, their Advantages, Limitations and Applications

1. Why draft allowances are important for patterns.
2. What are the importances of permeability of molding sand?
3. How runner extension is helpful for good casting quality.
4. Internal corners are more prone to solidification shrinkages than external corners. Explain?
5. Which of the casting processes would be suitable for making small toys in large numbers? Why?

### **Course Outcome 2 (CO2):**

Categorize welding processes according to welding principle and material

1. Why is the quality of welds produced by submerged arc welding very good?
2. What does the strength of a weld nugget in resistance spot welding depends on?
3. What is the strength of a welded joint is inferior or superior to the parent metal? Why?
4. Why some joints may have to be preheated prior to welding.

### **Part -B**

**Course Outcome 3 (CO3):** Understand requirements to achieve sound welded joint while welding different similar and dissimilar engineering materials.

1. Assume that you are asked to inspect a weld for a critical application. Describe the procedure you would follow. If you find a flaw during your inspection, how would you go about determining whether or not this flaw is important for the particular application?
2. In the building of large ships, there is a need to weld large sections of steel together to form a hull, for this application, which welding process would you select? Why?

**Course Outcome 4 (CO4):** Student will estimate the working loads for pressing, forging, wire drawing etc. processes

1. How can you tell whether a certain part is forged or cast? Describe the features that you would investigate to arrive at a conclusion.
2. Two solid cylindrical specimens A and B, made of a perfectly plastic material, are being forged with friction and isothermally at room temperature to a reduction in height of 50%. specimen A has a height of 2 inch and cross sectional area of 1 square inch, and specimen B has a height of is 1 inch and a cross sectional area of 2 square inch will the work done be the same for the two specimens? Explain.

**Course Outcome 5 (CO5):** Recommend appropriate part manufacturing processes when provided a set of functional requirements and product development constraints.

1. Many missile components are made by spinning. What other methods would you use to make missile components if spinning process were not available? Describe the relative advantages and limitations of each method.
2. Suggest a suitable casting process for making an engine piston with Aluminum alloy. What type of mould can be used?
3. Suggest and explain a suitable welding method for welding railway tracks for trains.
4. Suggest a suitable manufacturing process for screw jack, postulate the fundamentals.

## **SYLLABUS**

### **Module I**

Casting:-Characteristics of sand - patterns- cores- -chaplets- simple problems- solidification of metals and Chvorinov's rule - Elements of gating system- risering -chills –simple problems- Special casting process- Defects in castings- Super alloy Production Methods.

### **Module II**

Welding:-welding metallurgy-heat affected zone- grain size and hardness- stress relieving- joint quality -heat treatment of welded joints - weldability - destructive and non destructive tests of welded joints-

Thermit welding, friction welding - Resistance welding: HAZ, process and correlation of process parameters with welded joints - applications of each welding process- Arc welding:-HAZ, process and correlation of process parameters with welded joints- simple problems - applications of each welding process - Oxyacetylene welding:-chemistry, types of flame and its applications - brazing- soldering - adhesive bonding.

### **Module III**

Rolling:- principles - types of rolls and rolling mills - mechanics of flat rolling-Defects-vibration and chatter - flat rolling -miscellaneous rolling process- simple problems - Bulk deformation of metals :- State of stress; yield criteria of Tresca, von Mises, comparisons; Flow rules; power and energy deformations; Heat generation and heat transfer in metal forming process.

### **Module IV**

Forging: methods analysis, applications, die forging, defects in forging - simple problems - Metal extrusion:- metal flow, mechanics of extrusion, miscellaneous process, defects, simple problems, applications - Wire, Rod, and tube drawing:- mechanics of rod and wire drawing, simple problems, drawing defects - swaging, applications – deep drawing.

### **Module V**

Locating and clamping methods- locating methods- locating from plane, circular, irregular surface. Locating methods and devices- simple problems - Basic principles of clamping -Sheet metal operations- Press tool operations-Tension, Compression, tension and compression operations - applications - Fundamentals of die cutting operations - simple problems - types of die construction.

### **Text Books**

1. Donaldson Cyril, LeCain, Goold, Ghose:- Tool design, McGraw Hill.
2. Serope Kalpakjian, Steven R. Schmid - Manufacturing Engineering and Technology, Pearson.

### **Reference**

1. Joseph R. Davis, S. L. Semiatin, American Society for Metals - ASM Metals Handbook, Vol. 14 Forming and Forging ASM International (1989).
2. Peter Beeley, Foundry Technology, Butterworth-Heinemann
3. Rao P.N., Manufacturing Technology, Volume -1, Tata McGraw Hill.
4. Taylan Altan, Gracious Ngaile, Gangshu Shen - Cold and Hot Forging Fundamentals and Applications - ASM International (2004).
5. Matthew J. Donachie, Stephen J. Donachie, Super alloys A Technical Guide, Second Edition, 2002 ASM International.

## **MODEL QUESTION PAPER MANUFACTURING PROCESS - MET 204**

**Max. Marks : 100**

**Duration : 3 Hours**

### **Part – A**

**Answer all questions, each question carries 3 marks**

1. Why does porosity have detrimental effects on the mechanical properties of castings? Which physical properties like thermal and electrical conductivity also are affected by porosity? explain



2. Large parts cannot be manufactured by the centrifugal casting, comment on the statement.
3. What does the strength of a weld nugget in resistance spot welding depends on?
4. Explain how the atmosphere around the work piece affect the weld obtained in electron beam welding.
5. What is the importance of roll velocity and strip velocity?
6. Explain a suitable rolling process for making threaded fasteners.
7. Explain why forged parts withstand high loads compared to cast parts.
8. Explain why the die pressure in drawing process decreases towards the exit of the die.
9. What is the basic rule for applying clamping forces?
10. What is generally used as the basic reference plane for locating?

### **PART -B**

**Answer one full question from each module.**

#### **MODULE – 1**

11. What is gating ratio? What considerations affect its selection? What are the typical gating ratios for the following applications? (a) Grey iron bed castings made in cast steel, (b) Valve body castings made in cast steel, (c) Aluminum pistons for automobiles, (d) Large gun metal bushes for bearings (14 marks).

**OR**

12. Explain different types of casting defects in detail with effects of each defect on quality of the casting (14 marks).

#### **MODULE – 2**

13. a. Two plates were welded together and then the strength of the joint was tested. It is found that the weld was stronger than either of the plates. Do you think that the statement is incorrect? Postulate, giving valid reasons with neat sketches (7 marks).  
b. what are the methods available for controlling the distortions in welded assembly structure? Describe their relative effects and application(7 marks).

**OR**

14. a. Two 1-mm thick, flat Copper sheets are being spot welded using a current of 5000A and a current flow time of  $t=0.18$  seconds the electrodes are 5mm in diameter. Estimate the heat generated in the weld zone (7 marks).  
b. Explain why some joints may have to be preheated prior to welding? If the parts to be welded are preheated, is the likelihood that porosity will form increased or decreased? Explain(7 marks).

#### **MODULE – 3**

15. a. An annealed Copper strip 228mm wide and 25mm thick is rolled to a thickness 20mm in one pass. The roll radius is 300mm and the rolls rotate at 100rpm. Calculate the roll force and the power required in this operation (7 marks).  
b. A 100mm square billet is to be rolled into a rod of 12.5mm diameter. Draw the sequence of operations (7 marks).

**OR**

16. Explain the yield criteria of Tresca, von Mises and compare each other (14 marks).

**MODULE – 4**

17. a. Explain why crankshaft of an automobile is manufactured by forging and not by casting (7 marks).  
 b. Estimate the limiting drawing ratio that you would expect from a sheet metal that, when stretched by 23 percentages in length, decreases in thickness by 10 percentages (7 marks).

**OR**

18. a. Assume that you are reducing the diameter of two round rods, one by simple tension and the other by indirect extrusion. Which methods would be better? Explain (7 marks).  
 b. A cylindrical specimen made of annealed 4135 steel has a diameter of 6 inches and is 4inch high. It is upset by open die forging with flat dies to a height of 2inch at room temperature. Assuming that the coefficient of friction is 0.2, calculate the force required at the end of the stroke. Use average pressure formula (7 marks).

**MODULE – 5**

19. Estimate the force required in punching a 25mm diameter hole through a 3.2mm thick annealed Titanium Ti-6Al-4V sheet at room temperature (5 marks).  
 b. Explain 3-2-1 principle of locating with neat sketches (9 marks).

**OR**

20. a. determine the die and punch sizes for blanking a circular disc of 20mm diameter from a C20 steel sheet whose thickness is 1.5mm (7 marks).  
 b. Explain how is unevenness compensated for when locating against an irregular surface with more than three locating points? (7 marks).

**Course content and lecture schedules.**

Module	TOPIC	No. of hours	Course outcomes
1.1	Casting:-Characteristics of sand -pattern and allowances -type of patterns-cores-core prints-chaplets-simple problems.	2	CO1
1.2	Elements of gating system-gating system, pouring time, choke area - risering Caine's method-chills –simple problems.	2	CO1 CO5
1.3	Special casting process:-shell molding, precision investment, die casting, centrifugal casting, continues casting, squeeze casting surface roughness obtainable and application of each casting process.	2	
1.4	Defects in castings :- Shaping faults arising in pouring, Inclusions and sand defects, Gas defects, Shrinkage defects, Contraction defects, Dimensional errors, Compositional errors and segregation; significance of defects on Mechanical properties . (Kalpakjian, Beeley, Rao).	2	CO1
1.5	Superalloy Production Methods: Vacuum Induction Melting; Electroslag Remelting; Vacuum Arc Remelting (ASM).	1	
2.1	Welding:-welding metallurgy, diffusion, heat affected zone, driving force for grain growth, grain size and hardness- joint quality: porosity, slag inclusions, cracks, surface damage, residual stress lamellar tears, stress relieving, heat treatment of welded joints - weldability (Kalpakjian, Lindberg) - destructive and non destructive tests of welded joints (may be provided as class assignment - Lindberg).	2	CO2

2.2	Resistance welding: HAZ, process and correlation of process parameters with welded joints of spot, seam, projection, stud arc, percussion welding-applications of each welding process –simple problems. (Kalpakjian).	3	CO2 CO5
2.3	Arc welding:-HAZ, process and correlation of process parameters with welded joints of shielded metal arc, submerged, gas metal, flux cored, electrogas, electroslog, gas tungsten, plasma arc, electron beam, laser beam –simple problems - Thermit welding, friction welding- applications of each welding process. (Kalpakjian, Lindberg).	3	CO2
2.4	Oxyacetylene welding:-chemistry, types of flame and its applications - brazing- soldering - adhesive bonding.	1	
3.1	Rolling:- principles - types of rolls and rolling mills - mechanics of flat rolling, roll pressure distribution, neutral point, front and back tension, torque and power, roll forces in hot rolling, friction, deflection and flattening, spreading – simple problems.	3	CO4 CO5
3.2	rolling defects-vibration and chatter - flat rolling -miscellaneous rolling process: shape, roll forging, ring, thread and gear, rotary tube piercing, tube rolling - applications – simple problems. (Kalpakjian).	2	CO4
3.3	Plastic deformation of metals - stress-strain relationships- State of stress - yield criteria of Tresca, von Mises, and comparisons - applications.	2	
3.4	Flow rules -power and energy deformations - Heat generation and heat transfer in metal forming process -temperature in forging. (ASM- Taylan Altan).	1	CO4
4.1	Forging: material characterization; grain flow and strength - Forging:-classification - open die forging, forces and work of deformation - Forging methods analysis:- slab method only, solid cylindrical, rectangular work piece in plane strain, forging under sticking condition - simple problems -applications.	3	CO4
	Deformation zone geometry – die forging: - impression, close, coining, skew rolling etc. –simple problems– defects in forging. (Kalpakjian).	1	
4.2	Metal extrusion: - metal flow - mechanics of extrusion:-deformation and friction, actual forces, die angle, forces in hot extrusion - miscellaneous process- defects –simple problems- applications. (Kalpakjian, Lindberg).	2	
4.3	Wire, Rod, and tube drawing: - mechanics of rod and wire drawing: deformation, friction, die pressure and angle, temperature, reduction per pass, drawing flat strip and tubes- –simple problems- drawing defects- swaging-applications. (Kalpakjian, Lindberg, Rao).	2	CO4
4.4	Deep drawing- deep drawbility, simple problems - different drawing practices	1	
5.1	Locating and clamping methods: - basic principle of location; locating methods; degrees of freedom; locating from plane, circular, irregular surface –simple problems.	2	CO4
	Locating methods and devices: - pin and button locators, rest pads and plates, nest or cavity location.	1	

5.2	Basic principles of clamping:-strap, cam, screw, latch, wedge, hydraulic and pneumatic clamping –simple problems. (Donaldson, Wilson F.W.).	2	CO4
5.3	Sheet metal operations: Press tool operations: shearing action, shearing operations: blanking, piercing, simple problems, trimming, shaving, nibbing, notching – simple problems - applications.	2	CO4 CO5
5.4	Tension operations: stretch forming - Compression operations: - coining, sizing, ironing, hobbing - tension and compression operations: drawing, spinning, bending, forming, embossing – simple problems- applications. (Donaldson, Wilson F.W., Rao P.N).	2	CO4
	Fundamentals of die cutting operations - inverted, progressive and compound die - simple problems. (Donaldson)	1	

COURSE CODE	COURSE NAME	CATEGORY	L	T	P	CREDITS
22MET404	FLUID MACHINERY	ES	3	1	0	4

**Preamble :**

This course provides an understanding of reciprocating and rotary fluid machinery. The course consists of hydraulic pumps, turbines, air compressors and gas turbines

**Prerequisite :** NIL

**Course Outcomes :**

After completion of the course the student will be able to

CO1	Explain the characteristics of centrifugal and reciprocating pumps
CO2	Calculate forces and work done by a jet on fixed or moving plate and curved plates
CO3	Explain the working of turbines and Select a turbine for specific application.
CO4	Analyse the working of air compressors and Select the suitable one based on application.
CO5	Analyse gas turbines and Identify the improvements in basic gas turbine cycles.
CO6	Explain the characteristics of centrifugal and reciprocating pumps

**Mapping of course outcomes with program outcomes**

	PO1	PO2	PO3	PO4	PO5	PO6	PO7	PO8	PO9	PO10	PO11	PO12
CO1	3	3	2									
CO2	3	3	2									
CO3	3	3	2									
CO4	3	3	2									
CO5	3	3	2									

**Assessment Pattern**

Blooms Category	CA			ESA
	Assignment	Test - 1	Test - 2	
Remember	25	20	20	10
Understand	25	40	40	20
Apply	25	40	40	70
Analyse	25			
Evaluate				
Create				

**Continuous Internal Evaluation Pattern:**

Attendance : 10 marks

Continuous Assessment Test (2 numbers) : 25 marks

Assignment/Quiz/Course project : 15 marks

**Mark distribution & Duration of Examination :**

Total Marks	CA	ESE	ESE Duration
150	50	100	3 Hours

**End semester pattern:**

There will be two parts; Part A and Part B. Part A contain 10 questions with 2 questions from each module, having 3 marks for each question. Students should answer all questions. Part B contains 2 questions from each module of which student should answer any one. Each question can have maximum 2 sub-divisions and carry 14 marks.

## COURSE LEVEL ASSESSMENT QUESTIONS

### Course Outcome 1

1. A centrifugal pump discharges  $0.15 \text{ m}^3/\text{s}$  of water against a head of 12.5 m, the speed of the impeller being 600 r.p.m. The outer and inner diameters of impeller are 500 mm and 250 mm respectively and the vanes are bent back at  $35^\circ$  to the tangent at exit. If the area of flow remains  $0.07 \text{ m}^2$  from inlet to outlet, calculate :
  - (a) Manometric efficiency of pump,
  - (b) Vane angle at inlet, and
  - (c) Loss of head at inlet to impeller when discharge is reduced by 40% without changing the speed.
2.
  - (a) What is slip in a reciprocating pump. What is the reason for negative slip in a reciprocating pump.
  - (b) A single acting reciprocating pump having a bore of 150 mm and a stroke of 300 mm length, discharges 250 l of water per minute at 50 rpm. Neglecting losses, find theoretical discharge and slip of the pump.
  - (c) With a neat sketch explain the working of a gear pump.
3. Explain the following terms as they are applied to a centrifugal pump:
  - (a) Static suction lift,
  - (b) static suction head,
  - (c) static discharge head and
  - (d) total static head.

### Course Outcome 2

1. Prove that the force exerted by a jet of water on a fixed semi-circular plate in the direction of the jet when the jet strikes at the centre of the semi-circular plate is two times the force exerted by the jet on an fixed vertical plate.
2. Show that the angle of swing of a vertical hinged plate is given by

$$\sin \theta = \frac{\rho a V^2}{W}$$

where  $V$  = Velocity of the jet striking the plate,  $a$  = Area of the jet, and  $W$  = Weight of the plate.

3. A jet of water moving at  $60 \text{ m/s}$  is deflected by a vane moving at  $25 \text{ m/s}$  in a direction at  $30^\circ$  to the direction of the jet. The water jet leaves the blade normally to the motion of the vanes. Draw the inlet and outlet velocity triangles and find the vane angles for no shock at entry or exit. Take the relative velocity at outlet to be 0.85 of the relative velocity at inlet.

### Course Outcome 3

1. Explain the purpose of providing
  - (a) scroll casing
  - (b) stay vanes
  - (c) guide vanes, for a reaction turbine.
2. A Pelton wheel turbine has a mean bucket speed of  $12 \text{ m/s}$  with a jet of water flowing at a rate of  $900 \text{ l/s}$  under a head of  $40 \text{ m}$ . The bucket deflects the jet at an angle of  $165^\circ$ . Calculate the power given by the water to the runner and the hydraulic efficiency of the turbine. Draw the velocity triangle. Assume the coefficient of velocity to be  $0.96$ .
3.
  - (a) What are the unit quantities used to analyze the performance of hydraulic turbines. Explain its importance.
  - (b) What is specific speed of a turbine.

### Course Outcome 4

1. With a neat sketch explain the working of centrifugal compressors.
2. An ideal single stage single acting reciprocating compressor logs a displacement volume of  $14 \text{ litres}$  and a clearance volume of  $5\%$ . It intakes air at  $1 \text{ bar}$  and delivers the same at  $7 \text{ bar}$ . The compression is polytropic with an index of  $1.3$  and re-expansion is isentropic with an index of  $1.4$ . Determine the indicated work of a cycle.
3. What is surging in axial flow compressor? What are its effects? Describe briefly.

### Course Outcome 5

1. A gas turbine unit operates at a mass flow of  $30 \text{ kg/s}$ . Air enters the compressor at a pressure of  $1 \text{ bar}$  and temperature  $15^\circ \text{C}$  and is discharged from the compressor at a pressure of  $10.5 \text{ bar}$ . Combustion occurs at constant pressure and results in a temperature rise of  $420 \text{ K}$ . If the flow leaves the turbine at a pressure of  $1.2 \text{ bar}$ , determine the net power output from the unit and also the thermal efficiency. Take  $C_p = 1.005 \text{ kJ/kgK}$  and  $\gamma = 1.4$ .
2. Derive the expression for maximum specific work output of a gas turbine considering machine efficiencies.
3. Write a short note on different type of compression chambers used in a gas turbine engine.



# SYLLABUS

**Module 1:** Impact of jets: Introduction to hydrodynamic thrust of jet on a fixed and moving surface (flat and curve),– Series of vanes - work done and efficiency. Hydraulic Turbines : Impulse and Reaction Turbines – Degree of reaction – Pelton Wheel – Constructional features - Velocity triangles – Euler’s equation – Speed ratio, jet ratio and work done, losses and efficiencies, design of Pelton wheel – Inward and outward flow reaction turbines- Francis Turbine – Constructional features – Velocity triangles, work done and efficiencies. Axial flow turbine (Kaplan) Constructional features – Velocity triangles- work done and efficiencies

**Module 2:** Characteristic curves of turbines – theory of draft tubes – surge tanks – Cavitation in turbines – Governing of turbines – Specific speed of turbine , Type Number– Characteristic curves, scale Laws – Unit speed – Unit discharge and unit power. Rotary motion of liquids – free, forced and spiral vortex flows Rotodynamic pumps- centrifugal pump impeller types,-velocity triangles-manometric head- work, efficiency and losses, H-Q characteristic, typical flow system characteristics, operating point of a pump. Cavitation in centrifugal pumps- NPSH required and available- Type number-Pumps in series and parallel operations. Performance characteristics- Specific speed-Shape numbers – Impeller shapes based on shape numbers.

**Module 3:** Positive displacement pumps- reciprocating pump – Single acting and double acting- slip, negative slip and work required and efficiency- indicator diagram- acceleration head - effect of acceleration and friction on indicator diagram – speed calculation- Air vessels and their purposes, saving in work done to air vessels multi cylinder pumps. Multistage pumps-selection of pumps-pumping devices-hydraulic ram, Accumulator, Intensifier, Jet pumps, gear pumps, vane pump and lobe pump.

**Module 4:** Compressors: classification of compressors, reciprocating compressor-single stage compressor, equation for work with and without clearance volume, efficiencies, multistage compressor, intercooler, free air delivered (FAD). Centrifugal compressor-working, velocity diagram, work done, power required, width of blades of impeller and diffuser, isentropic efficiency, slip factor and pressure coefficient, surging and choking. Axial flow compressors:- working, velocity diagram, degree of reaction, performance. Roots blower, vane compressor, screw compressor.

**Module 5** Gas turbines: classification, Thermodynamic analysis of gas turbine cycles-open, closed and semi closed cycle; ideal working cycle- Brayton cycle-P-v and T-s diagram, thermal efficiency. Effect of compressor and turbine efficiencies. Optimum pressure ratio for maximum specific work output with and without considering machine efficiencies. Comparison of gas turbine and IC engines, Analysis of open cycle gas turbine, Improvements of the basic gas turbine cycles-regeneration, intercooling and reheating-cycle efficiency and work output-Condition for minimum compressor work and maximum turbine work. Combustion chambers for gas turbines. pressure loss in combustion process and stability loop.

## Text books

Subramanya, K., Hydraulic Machines, Tata McGraw Hill, 1<sup>st</sup> edition, 2017

Rathore, M., Thermal Engineering, Tata McGraw Hill, 1<sup>st</sup> edition, 2010

## Reference Books

Ganesan, V., Gas Turbines, Tata McGraw Hill, 3<sup>rd</sup> edition, 2017.

Sawhney G.S., Thermal and Hydraulic Machines, Prentice Hall India Learning Private Limited; 2<sup>nd</sup> edition, 2011

## COURSE PLAN

Module	Topics	Hours Allotted
I	Impact of jets: Introduction to hydrodynamic thrust of jet on a fixed and moving surface (flat and curve),– Series of vanes - work done and efficiency Hydraulic Turbines : Impulse and Reaction Turbines – Degree of reaction – Pelton Wheel – Constructional features - Velocity triangles – Euler’s equation – Speed ratio, jet ratio and work done, losses and efficiencies, design of Pelton wheel – Inward and outward flow reaction turbines- Francis Turbine – Constructional features – Velocity triangles, work done and efficiencies. Axial flow turbine (Kaplan) Constructional features – Velocity triangles- work done and efficiencies	6-3-0
II	Characteristic curves of turbines – theory of draft tubes – surge tanks – Cavitation in turbines – Governing of turbines – Specific speed of turbine , Type Number– Characteristic curves, scale Laws – Unit speed – Unit discharge and unit power. Rotary motion of liquids – free, forced and spiral vortex flows Rotodynamic pumps- centrifugal pump impeller types,-velocity triangles- manometric head- work, efficiency and losses, H-Q characteristic, typical flow system characteristics, operating point of a pump. Cavitation in centrifugal pumps- NPSH required and available- Type number-Pumps in series and parallel operations. Performance characteristics- Specific speed-Shape numbers – Impeller shapes based on shape numbers.	7-2-0
III	Positive displacement pumps- reciprocating pump – Single acting and double acting- slip, negative slip and work required and efficiency- indicator diagram- acceleration head - effect of acceleration and friction on indicator diagram – speed calculation- Air vessels and their purposes, saving in work done to air vessels multi cylinder pumps. Multistage pumps-selection of	7-2-0

	pumps-pumping devices-hydraulic ram, Accumulator, Intensifier, Jet pumps, gear pumps, vane pump and lobe pump.	
<b>IV</b>	Compressors: classification of compressors, reciprocating compressor-single stage compressor, equation for work with and without clearance volume, efficiencies, multistage compressor, intercooler, free air delivered (FAD) Centrifugal compressor-working, velocity diagram, work done, power required, width of blades of impeller and diffuser, isentropic efficiency, slip factor and pressure coefficient, surging and choking. Axial flow compressors:- working, velocity diagram, degree of reaction, performance. Roots blower, vane compressor, screw compressor.	7-2-0
<b>V</b>	Gas turbines: classification, Thermodynamic analysis of gas turbine cycles- open, closed and semi closed cycle; ideal working cycle- Brayton cycle-P-v and T-s diagram, thermal efficiency. Effect of compressor and turbine efficiencies. Optimum pressure ratio for maximum specific work output with and without considering machine efficiencies. Comparison of gas turbine and IC engines, Analysis of open cycle gas turbine, Improvements of the basic gas turbine cycles-regeneration, intercooling and reheating-cycle efficiency and work output-Condition for minimum compressor work and maximum turbine work. Combustion chambers for gas turbines. pressure loss in combustion process and stability loop.	7-2-0

**MODEL QUESTION PAPER**  
**IV SEMESTER B.TECH DEGREE EXAMINATION**  
**MET206: FLUID MACHINERY**  
Mechanical Engineering

Maximum: 100 Marks

Duration: 3 hours

**PART A**

Answer all questions, each question carries 3 marks

1. What is degree of reaction? What will be the degree of reaction for a Pelton wheel.
2. Explain speed ratio and jet ratio.
3. What is governing of a turbine? Why is it important?
4. Explain the term specific speed of a pump. How is it different from specific speed of a turbine.
5. Define slip, percentage slip and negative slip of a reciprocating pump.
6. What is the purpose of air vessels in multi-cylinder reciprocating pump.
7. What are the classifications of compressors? Explain briefly.
8. Write a short note on axial flow compressors. Why is it preferred in aerospace applications.
9. Explain briefly the process of regeneration in a gas turbine engine.
10. Draw the p-v diagram and T-s diagram of Brayton cycle.

(10×3=30 Marks)

**PART B**

Answer one full question from each module

**MODULE-I**

11. (a) A 50 mm diameter jet having a velocity of 25 *m/s*, strikes a flat plate, the normal of which is inclined at 30° to the axis of the jet. Calculate the normal force exerted on the plate
  - i. when the plate is stationary,
  - ii. when the plate is moving with a velocity of 10 *m/s* in the direction of the jet.Find also the work done and the efficiency of the jet when the plate is moving.  
(7 Marks)

- (b) A Pelton wheel has a mean bucket speed of  $10 \text{ m/s}$  with a jet of water flowing at the rate of  $700 \text{ litres/s}$  under a head of  $30 \text{ m}$ . The buckets deflect the jet through an angle of  $160^\circ$ . Calculate the power given by the water to the runner and the hydraulic efficiency of the turbine. Assume coefficient of velocity as  $0.98$ . (7 Marks)
12. (a) A reaction turbine works at  $450 \text{ rpm}$  under a head of  $120 \text{ m}$ . Its diameter at inlet is  $120 \text{ cm}$  and the flow area is  $0.4 \text{ m}^2$ . The angles made by absolute and relative velocities at inlet are  $20^\circ$  and  $60^\circ$  respectively with the tangential velocity. Determine:
- The volume flow rate,
  - The power developed, and
  - Hydraulic efficiency.
- Assume whirl at outlet to be zero. (7 Marks)
- (b) A Kaplan turbine runner is to be designed to develop  $7357.5 \text{ kW}$  shaft power. The net available head is  $10 \text{ m}$ . Assume that the speed ratio is  $1.8$  and flow ratio is  $0.6$ . If the overall efficiency is  $70\%$  and diameter of the boss is  $0.4$  times the diameter of the runner, find the diameter of the runner, its speed and specific speed. (7 Marks)

### MODULE-II

13. (a) A Pelton wheel is revolving at a speed of  $190 \text{ rpm}$  and develops  $5150.25 \text{ kW}$  when working under a head of  $220 \text{ m}$  with an overall efficiency of  $80\%$ . Determine unit speed, unit discharge and unit power. The speed ratio for the turbine is given as  $0.47$ . Find the speed, discharge and power when this turbine is working under a head of  $140 \text{ m}$ . (7 Marks)
- (b) What do you understand by the characteristic curves of a turbine? Describe the important types of characteristic curves. (7 Marks)
14. (a) Why are centrifugal pumps used sometimes in series and sometimes in parallel? Draw the following characteristic curves for a centrifugal pump:  
Head, power and efficiency versus discharge with constant speed. (7 Marks)
- (b) State the effects of cavitation on the performance of water turbines and also state how to prevent cavitation in water turbines. (7 Marks)

### MODULE-III

15. (a) Draw an indicator diagram, considering the effect of acceleration and friction in suction and delivery pipes. Find an expression for the work done per second in case of single-acting reciprocating pump. (7 Marks)
- (b) Differentiate :
- Between a single-acting and double-acting reciprocating pump,
  - Between a single cylinder and a double cylinder reciprocating pump. (7 Marks)
16. (a) A single-acting reciprocating pump running at  $30 \text{ r.p.m}$ , delivers  $0.012 \text{ m}^3/\text{s}$  of water. The diameter of the piston is  $25 \text{ cm}$  and stroke length is  $50 \text{ cm}$ . Determine :
- The theoretical discharge of the pump,
  - Coefficient of discharge, and
  - Slip and percentage slip of the pump. (8 Marks)
- (b) Write a short note on gear pumps. Why gear pump is known as positive displacement pump. (6 Marks)

## MODULE-IV

17. (a) With a neat sketch explain the working of an axial flow compressor. (7 Marks)
- (b) Derive the expression for the work done in a reciprocating compressor with and without clearance volume. (7 Marks)
18. (a) A single stage double acting air compressor is required to deliver  $14 \text{ m}^3$  of air per minute measured at 1.013 bar and  $15^\circ\text{C}$ . The delivery pressure is 7 bar and the speed 300 rpm. Take clearance volume as 5% of the swept volume with compression and expansion index  $n=1.3$ . Calculate
- Swept volume of the cylinder,
  - Delivery temperature,
  - Indicated power.
- (10 Marks)
- (b) Draw the velocity diagram of an axial flow compressor. (4 Marks)

## MODULE-V

19. (a) The air enters the compressor of an open cycle constant pressure gas turbine at a pressure of 1 bar and temperature  $20^\circ\text{C}$ . The pressure of air after compression is 4 bar. The isentropic efficiencies of compressor and turbine are 80% and 85% respectively. The air fuel ratio is 90:1. If flow rate of air is  $3.0 \text{ kg/s}$ , find
- Power developed
  - Thermal efficiency of cycle
- (7 Marks)
- (b) A gas turbine has a pressure ratio of 6:1 and a maximum cycle temperature of  $600^\circ\text{C}$ . The isentropic efficiencies of compressor and turbine are 0.82 and 0.85 respectively. Calculate the power output in kW of an electric generator geared to turbine when the air enters the compressor at  $15^\circ\text{C}$  at the rate of  $15 \text{ kg/s}$ . Assume the working fluid to be air with  $C_p = 1.005$  and  $\gamma = 1.4$ . (7 Marks)
20. (a) What are the improvements made to the basic gas turbine cycle. Explain with temperature entropy diagram. (8 Marks)
- (b) Differentiate between open, closed and semi closed gas turbine cycles. (6 Marks)

COURSE CODE	COURSE NAME	CATEGORY	L	T	P	CREDITS
22EST405	DESIGN AND ENGINEERING	ES	2	0	0	2

**Preamble:**

The purpose of this course is to

- i) introduce the undergraduate engineering students the fundamental principles of design engineering,
- ii) make them understand the steps involved in the design process and
- iii) familiarize them with the basic tools used and approaches in design.

Students are expected to apply design thinking in learning as well as while practicing engineering, which is very important and relevant for today. Case studies from various practical situations will help the students realize that design is not only concerned about the function but also many other factors like customer requirements, economics, reliability, etc. along with a variety of life cycle issues.

The course will help students to consider aesthetics, ergonomics and sustainability factors in designs and also to practice professional ethics while designing.

**Prerequisite:**

**Nil.** The course will be generic to all engineering disciplines and will not require specialized preparation or prerequisites in any of the individual engineering disciplines.

**Course Outcomes:**

After the completion of the course the student will be able to

<b>CO 1</b>	Explain the different concepts and principles involved in design engineering.
<b>CO 2</b>	Apply design thinking while learning and practicing engineering.
<b>CO 3</b>	Develop innovative, reliable, sustainable and economically viable designs incorporating knowledge in engineering.

**Mapping of course outcomes with program outcomes**

	PO 1	PO 2	PO 3	PO 4	PO 5	PO 6	PO 7	PO 8	PO 9	PO 10	PO 11	PO 12
<b>CO 1</b>	2	1					1			1		
<b>CO 2</b>		2				1		1				2
<b>CO 3</b>			2			1	1		2	2		1

## Assessment Pattern

### Continuous Internal Evaluation (CIE) Pattern:

Attendance : 10 marks

Continuous Assessment Test (2 numbers) : 25 marks

Assignment/Quiz/Course project : 15 marks

### End Semester Examination (ESE) Pattern: There will be two parts; Part A and Part B.

Part A : 30 marks

part B : 70 marks

Part A contains 10 questions with 2 questions from each module, having 3 marks for each question. Students should answer all questions.

Part B contains 2 case study questions from each module of which student should answer any one. Each question carry 14 marks and can have maximum 2 sub questions.

### Mark distribution

Total Marks	CIE	ESE	ESE Duration
150	50	100	3 hours

Bloom's Category	Continuous Assessment Tests		End Semester Examination
	1	2	
Remember	5	5	10
Understand	10	10	20
Apply	35	35	70
Analyse	-	-	-
Evaluate	-	-	-
Create	-	-	-



## **Course Level Assessment Questions**

### **Course Outcome 1 (CO1): Appreciate the different concepts and principles involved in design engineering.**

1. State how engineering design is different from other kinds of design
2. List the different stages in a design process.
3. Describe design thinking.
4. State the function of prototyping and proofing in engineering design.
5. Write notes on the following concepts in connection with design engineering 1) Modular Design, 2) Life Cycle Design, 3) Value Engineering, 4) Concurrent Engineering, and 5) Reverse Engineering
6. State design rights.

### **Course Outcome 2 (CO2) Apply design thinking while learning and practicing engineering.**

1. Construct the iterative process for design thinking in developing simple products like a pen, umbrella, bag, etc.
2. Show with an example how divergent-convergent thinking helps in generating alternative designs and then how to narrow down to the best design.
3. Describe how a problem-based learning helps in creating better design engineering solutions.
4. Discuss as an engineer, how ethics play a decisive role in your designs

### **Course Outcome 3 (CO3): Develop innovative, reliable, sustainable and economically viable designs incorporating different segments of knowledge in engineering.**

1. Illustrate the development of any simple product by passing through the different stages of design process
2. Show the graphical design communication with the help of detailed 2D or 3D drawings for any simple product.
3. Describe how to develop new designs for simple products through bio-mimicry.

**Model Question paper**

Page 1 of 2

Reg No.: \_\_\_\_\_ Name: \_\_\_\_\_

**THIRD/FOURTH SEMESTER B.TECH DEGREE EXAMINATION**

**Course Code: EST 200**

**Course Name: DESIGN AND ENGINEERING**

**Max. Marks: 100 Duration: 3 Hours**

**PART A**

**Answer all questions, each question carries 3 marks**

**Use only hand sketches**

- (1) Write about the basic design process.
- (2) Describe how to finalize the design objectives.
- (3) State the role of divergent-convergent questioning in design thinking.
- (4) Discuss how to perform design thinking in a team managing the conflicts.
- (5) Show how engineering sketches and drawings convey designs.
- (6) Explain the role of mathematics and physics in design engineering process.
- (7) Distinguish between project-based learning and problem-based learning in design engineering.
- (8) Describe how concepts like value engineering, concurrent engineering and reverse engineering influence engineering designs?
- (9) Show how designs are varied based on the aspects of production methods, life span, reliability and environment?
- (10) Explain how economics influence the engineering designs?

**(10x3 marks =30 marks)**

**Part B**

**Answer any ONE question from each module. Each question carry 14 marks**

**Module 1**

- (11) Show the designing of a wrist watch going through the various stages of the design process. Use hand sketches to illustrate the processes.  
or
- (12) Find the customer requirements for designing a new car showroom. Show how the design objectives were finalized considering the design constraints?

### **Module 2**

(13) Illustrate the design thinking approach for designing a bag for college students within a limited budget. Describe each stage of the process and the iterative procedure involved. Use hand sketches to support your arguments.

**or**

(14) Construct a number of possible designs and then refine them to narrow down to the best design for a drug trolley used in hospitals. Show how the divergent-convergent thinking helps in the process. Provide your rationale for each step by using hand sketches only.

### **Module 3**

(15) Graphically communicate the design of a thermo flask used to keep hot coffee. Draw the detailed 2D drawings of the same with design detailing, material selection, scale drawings, dimensions, tolerances, etc. Use only hand sketches.

**or**

(16) Describe the role of mathematical modelling in design engineering. Show how mathematics and physics play a role in designing a lifting mechanism to raise 100 kg of weight to a floor at a height of 10 meters in a construction site.

### **Module 4**

(17) Show the development of a nature inspired design for a solar powered bus waiting shed beside a highway. Relate between natural and man-made designs. Use hand sketches to support your arguments.

**or**

(18) Show the design of a simple sofa and then depict how the design changes when considering 1) aesthetics and 2) ergonomics into consideration. Give hand sketches and explanations to justify the changes in designs.

### **Module 5**

(19) Examine the changes in the design of a foot wear with constraints of 1) production methods, 2) life span requirement, 3) reliability issues and 4) environmental factors. Use hand sketches and give proper rationalization for the changes in design.

**or**

(20) Describe how to estimate the cost of a particular design using ANY of the following: i) a website, ii) the layout of a plant, iii) the elevation of a building, iv) an electrical or electronic system or device and v) a car.

Show how economics will influence the engineering designs. Use hand sketches to support your arguments.

**(5x14 marks =70 marks)**

## Syllabus

### Module 1

Design Process:- Introduction to Design and Engineering Design, Defining a Design Process:-Detailing Customer Requirements, Setting Design Objectives, Identifying Constraints, Establishing Functions, Generating Design Alternatives and Choosing a Design.

### Module 2

Design Thinking Approach:-Introduction to Design Thinking, Iterative Design Thinking Process Stages: Empathize, Define, Ideate, Prototype and Test. Design Thinking as Divergent-Convergent Questioning. Design Thinking in a Team Environment.

### Module 3

Design Communication (Languages of Engineering Design):-Communicating Designs Graphically, Communicating Designs Orally and in Writing. Mathematical Modeling In Design, Prototyping and Proofing the Design.

### Module 4

Design Engineering Concepts:-Project-based Learning and Problem-based Learning in Design.Modular Design and Life Cycle Design Approaches. Application of Biomimicry,Aesthetics and Ergonomics in Design. Value Engineering, Concurrent Engineering, and Reverse Engineering in Design.

### Module 5

Expediency, Economics and Environment in Design Engineering:-Design for Production, Use, and Sustainability. Engineering Economics in Design. Design Rights. Ethics in Design

### Text Books

- 1) YousefHaik, SangarappillaiSivaloganathan, Tamer M. Shahin, Engineering Design Process, Cengage Learning 2003, Third Edition, ISBN-10: 9781305253285,
- 2) Voland, G., Engineering by Design, Pearson India 2014, Second Edition, ISBN 9332535051

### Reference Books

- 1.Philip Kosky, Robert Balmer, William Keat, George Wise, Exploring Engineering, Fourth Edition: An Introduction to Engineering and Design, Academic Press 2015, 4th Edition, ISBN: 9780128012420.
2. Clive L. Dym, Engineering Design: A Project-Based Introduction, John Wiley & Sons, New York 2009, Fourth Edition, ISBN: 978-1-118-32458-5
3. Nigel Cross, Design Thinking: Understanding How Designers Think and Work, Berg Publishers 2011, First Edition, ISBN: 978-1847886361
4. Pahl, G., Beitz, W., Feldhusen, J., Grote, K.-H., Engineering Design: A Systematic Approach, Springer 2007, Third Edition, ISBN 978-1-84628-319-2

## Course Contents and Lecture Schedule

No	Topic	No. of Lectures
1	<b><u>Module 1: Design Process</u></b>	
1.1	Introduction to Design and Engineering Design. <i>What does it mean to design something? How Is engineering design different from other kinds of design? Where and when do engineers design? What are the basic vocabulary in engineering design? How to learn and do engineering design.</i>	1
1.2	<i>Defining a Design Process-</i> : Detailing Customer Requirements. <i>How to do engineering design? Illustrate the process with an example. How to identify the customer requirements of design?</i>	1
1.3	<i>Defining a Design Process-</i> : Setting Design Objectives, Identifying Constraints, Establishing Functions. <i>How to finalize the design objectives? How to identify the design constraints? How to express the functions a design in engineering terms?</i>	1
1.4	<i>Defining a Design Process-</i> : Generating Design Alternatives and Choosing a Design. <i>How to generate or create feasible design alternatives? How to identify the "best possible design"?</i>	1
1.5	Case Studies:- Stages of Design Process. <i>Conduct exercises for designing simple products going through the different stages of design process.</i>	1
2	<b><u>Module 2: Design Thinking Approach</u></b>	
2.1	Introduction to Design Thinking <i>How does the design thinking approach help engineers in creating innovative and efficient designs?</i>	1
2.2	Iterative Design Thinking Process Stages: Empathize, Define, Ideate, Prototype and Test. <i>How can the engineers arrive at better designs utilizing the iterative design thinking process (in which knowledge acquired in the later stages can be applied back to the earlier stages)?</i>	1
2.3	Design Thinking as Divergent-Convergent Questioning. <i>Describe how to create a number of possible designs and then how to refine and narrow down to the 'best design'.</i>	1
2.4	Design Thinking in a Team Environment. <i>How to perform design thinking as a team managing the conflicts ?</i>	1
2.5	Case Studies: Design Thinking Approach. <i>Conduct exercises using the design thinking approach for</i>	1

	<i>designing any simple products within a limited time and budget</i>	
<b>3</b>	<b><u>Module 3: Design Communication (Languages of Engineering Design)</u></b>	
3.1	Communicating Designs Graphically. <i>How do engineering sketches and drawings convey designs?</i>	1
3.2	Communicating Designs Orally and in Writing. <i>How can a design be communicated through oral presentation or technical reports efficiently?</i>	1
<b>First Series Examination</b>		
3.3	Mathematical Modelling in Design. <i>How do mathematics and physics become a part of the design process?</i>	1
3.4	Prototyping and Proofing the Design. <i>How to predict whether the design will function well or not?</i>	1
3.5	Case Studies: Communicating Designs Graphically. <i>Conduct exercises for design communication through detailed 2D or 3D drawings of simple products with design detailing, material selection, scale drawings, dimensions, tolerances, etc.</i>	1
<b>4</b>	<b><u>Module 4: Design Engineering Concepts</u></b>	
4.1	Project-based Learning and Problem-based Learning in Design. <i>How engineering students can learn design engineering through projects?</i> <i>How students can take up problems to learn design engineering?</i>	1
4.2	Modular Design and Life Cycle Design Approaches. <i>What is modular approach in design engineering? How it helps?</i> <i>How the life cycle design approach influences design decisions?</i>	1
4.3	Application of Bio-mimicry, Aesthetics and Ergonomics in Design. <i>How do aesthetics and ergonomics change engineering designs?</i> <i>How do the intelligence in nature inspire engineering designs? What are the common examples of bio-mimicry in engineering?</i>	1
4.4	Value Engineering, Concurrent Engineering, and Reverse Engineering in Design. <i>How do concepts like value engineering , concurrent engineering and reverse engineering influence engineering designs?</i>	1
4.5	Case Studies: Bio-mimicry based Designs. <i>Conduct exercises to develop new designs for simple</i>	1

	<i>products using bio-mimicry and train students to bring out new nature inspired designs.</i>	
5	<b><u>Module 5: Expediency, Economics and Environment in Design Engineering</u></b>	
5.1	Design for Production, Use, and Sustainability. <i>How designs are finalized based on the aspects of production methods, life span, reliability and environment?</i>	1
5.2	Engineering Economics in Design. <i>How to estimate the cost of a particular design and how will economics influence the engineering designs?</i>	1
5.3	Design Rights. <i>What are design rights and how can an engineer put it into practice?</i>	1
5.4	Ethics in Design. <i>How do ethics play a decisive role in engineering design?</i>	1
5.5	Case Studies: Design for Production, Use, and Sustainability. <i>Conduct exercises using simple products to show how designs change with constraints of production methods, life span requirement, reliability issues and environmental factors.</i>	1
<b>Second Series Examination</b>		

COURSE CODE	COURSE NAME	CATEGORY	L	T	P	CREDITS
22HUT406	PROFESSIONAL ETHICS	HU	2	0	0	2

**Preamble:** To enable students to create awareness on ethics and human values.

**Prerequisite:** Nil

**Course Outcomes:** After the completion of the course the student will be able to

<b>CO 1</b>	Understand the core values that shape the ethical behaviour of a professional.
<b>CO 2</b>	Adopt a good character and follow an ethical life.
<b>CO 3</b>	Explain the role and responsibility in technological development by keeping personal ethics and legal ethics.
<b>CO 4</b>	Solve moral and ethical problems through exploration and assessment by established experiments.
<b>CO 5</b>	Apply the knowledge of human values and social values to contemporary ethical values and global issues.

**Mapping of course outcomes with program outcomes**

	PO 1	PO 2	PO 3	PO 4	PO 5	PO 6	PO 7	PO 8	PO 9	PO1 0	PO1 1	PO1 2
<b>CO 1</b>								2			2	
<b>CO 2</b>								2			2	
<b>CO 3</b>								3			2	
<b>CO 4</b>								3			2	
<b>CO 5</b>								3			2	

**Assessment Pattern**

Bloom's category	Continuous Assessment Tests		End Semester Exam
	1	2	
Remember	15	15	30
Understood	20	20	40
Apply	15	15	30

**Mark distribution**

Total Marks	CIE	ESE	ESE Duration
150	50	100	3 hours



### **Continuous Internal Evaluation Pattern:**

Attendance	: 10 marks
Continuous Assessment Tests (2 Nos)	: 25 marks
Assignments/Quiz	: 15 marks

**End Semester Examination Pattern:** There will be two parts; Part A and Part B. Part A contains 10 questions with 2 questions from each module, having 3 marks for each question. Students should answer all questions. Part B contains 2 questions from each module of which student should answer any one. Each question can have maximum 2 sub-divisions and carry 14 marks.

### **Course Level Assessment Questions**

#### **Course Outcome 1 (CO1):**

1. Define integrity and point out ethical values.
2. Describe the qualities required to live a peaceful life.
3. Explain the role of engineers in modern society.

#### **Course Outcome 2 (CO2)**

1. Derive the codes of ethics.
2. Differentiate consensus and controversy.
3. Discuss in detail about character and confidence.

#### **Course Outcome 3(CO3):**

1. Explain the role of professional's ethics in technological development.
2. Distinguish between self interest and conflicts of interest.
3. Review on industrial standards and legal ethics.

#### **Course Outcome 4 (CO4):**

1. Illustrate the role of engineers as experimenters.
2. Interpret the terms safety and risk.
3. Show how the occupational crimes are resolved by keeping the rights of employees.

#### **Course Outcome 5 (CO5):**

1. Exemplify the engineers as managers.
2. Investigate the causes and effects of acid rain with a case study.
3. Explore the need of environmental ethics in technological development.

**Model Question paper**

QP CODE:

Reg No: \_\_\_\_\_

PAGES:3

Name : \_\_\_\_\_

**THIRD/FOURTH SEMESTER B.TECH DEGREE EXAMINATION, MONTH & YEAR**

**Course Code: HUT 200**

**Course Name: PROFESSIONAL ETHICS**

**Max. Marks: 100**

**Duration: 3 Hours**

**(2019-Scheme)**

**PART A**

**(Answer all questions, each question carries 3 marks)**

1. Define empathy and honesty.
2. Briefly explain about morals, values and ethics.
3. Interpret the two forms of self-respect.
4. List out the models of professional roles.
5. Indicate the advantages of using standards.
6. Point out the conditions required to define a valid consent?
7. Identify the conflicts of interests with an example?
8. Recall confidentiality.
9. Conclude the features of biometric ethics.
10. Name any three professional societies and their role relevant to engineers.

(10x3 = 30 marks)

**PART B**

**(Answer one full question from each module, each question carries 14 marks)**

**MODULE I**

11. a) Classify the relationship between ethical values and law?

b) Compare between caring and sharing.

(10+4 = 14 marks)

**Or**

12. a) Exemplify a comprehensive review about integrity and respect for others.

**b)** Discuss about co-operation and commitment. (8+6 = 14 marks)

## **MODULE II**

**13.a)** Explain the three main levels of moral developments, devised by Kohlberg.

**b)** Differentiate moral codes and optimal codes. (10+4 = 14 marks)

**Or**

**14. a)** Extrapolate the duty ethics and right ethics.

**b)** Discuss in detail the three types of inquiries in engineering ethics (8+6 = 14 marks)

## **MODULE III**

**15.a)** Summarize the following features of morally responsible engineers.

**(i)** Moral autonomy

**(ii)** Accountability

**b)** Explain the rights of employees (8+6 = 14 marks)

**Or**

**16. a)** Explain the reasons for Chernobyl mishap ?

**b)** Describe the methods to improve collegiality and loyalty. (8+6 = 14 marks)

## **MODULE IV**

**17.a)** Execute collegiality with respect to commitment, respect and connectedness.

**b)** Identify conflicts of interests with an example. (8+6 = 14 marks)

**Or**

**18. a)** Explain in detail about professional rights and employee rights.

**b)** Exemplify engineers as managers.

## **MODULE V**

**19.a)** Evaluate the technology transfer and appropriate technology.

**b)** Explain about computer and internet ethics. (8+6 = 14 marks)

**Or**

**20. a)** Investigate the causes and effects of acid rain with a case study.

**b)** Conclude the features of ecocentric and biocentric ethics. (8+6 = 14 marks)

## Syllabus

### **Module 1 – Human Values.**

Morals, values and Ethics – Integrity- Academic integrity-Work Ethics- Service Learning- Civic Virtue- Respect for others- Living peacefully- Caring and Sharing- Honestly- courage-Cooperation commitment- Empathy-Self Confidence -Social Expectations.

### **Module 2 - Engineering Ethics & Professionalism.**

Senses of Engineering Ethics - Variety of moral issues- Types of inquiry- Moral dilemmas –Moral Autonomy – Kohlberg’s theory- Gilligan’s theory- Consensus and Controversy-Profession and Professionalism- Models of professional roles-Theories about right action –Self interest-Customs and Religion- Uses of Ethical Theories.

### **Module 3- Engineering as social Experimentation.**

Engineering as Experimentation – Engineers as responsible Experimenters- Codes of Ethics- Plagiarism- A balanced outlook on law - Challenges case study- Bhopal gas tragedy.

### **Module 4- Responsibilities and Rights.**

Collegiality and loyalty – Managing conflict- Respect for authority- Collective bargaining- Confidentiality- Role of confidentiality in moral integrity-Conflicts of interest- Occupational crime- Professional rights- Employee right- IPR Discrimination.

### **Module 5- Global Ethical Issues.**

Multinational Corporations- Environmental Ethics- Business Ethics- Computer Ethics -Role in Technological Development-Engineers as Managers- Consulting Engineers- Engineers as Expert witnesses and advisors-Moral leadership.

### **Text Book**

1. M Govindarajan, S Natarajan and V S Senthil Kumar, Engineering Ethics, PHI Learning Private Ltd, New Delhi,2012.
2. R S Naagarazan, A text book on professional ethics and human values, New age international (P) limited ,New Delhi,2006.

### **Reference Books**

1. Mike W Martin and Roland Schinzinger, Ethics in Engineering,4<sup>th</sup> edition, Tata McGraw Hill Publishing Company Pvt Ltd, New Delhi,2014.
2. Charles D Fleddermann, Engineering Ethics, Pearson Education/ Prentice Hall of India, New Jersey,2004.
3. Charles E Harris, Michael S Protchard and Michael J Rabins, Engineering Ethics- Concepts and cases, Wadsworth Thompson Learning, United states,2005.
4. <http://www.slideword.org/slidestag.aspx/human-values-and-Professional-ethics>.

### Course Contents and Lecture Schedule

SL.No	Topic	No. of Lectures
<b>1</b>	<b>Module 1 – Human Values.</b>	
1.1	Morals, values and Ethics, Integrity, Academic Integrity, Work Ethics	1
1.2	Service Learning, Civic Virtue, Respect for others, Living peacefully	1
1.3	Caring and Sharing, Honesty, Courage, Co-operation commitment	2
1.4	Empathy, Self Confidence, Social Expectations	1
<b>2</b>	<b>Module 2- Engineering Ethics &amp; Professionalism.</b>	
2.1	Senses of Engineering Ethics, Variety of moral issues, Types of inquiry	1
2.2	Moral dilemmas, Moral Autonomy, Kohlberg's theory	1
2.3	Gilligan's theory, Consensus and Controversy, Profession & Professionalism, Models of professional roles, Theories about right action	2
2.4	Self interest-Customs and Religion, Uses of Ethical Theories	1
<b>3</b>	<b>Module 3- Engineering as social Experimentation.</b>	
3.1	Engineering as Experimentation, Engineers as responsible Experimenters	1
3.2	Codes of Ethics, Plagiarism, A balanced outlook on law	2
3.3	Challenger case study, Bhopal gas tragedy	2
<b>4</b>	<b>Module 4- Responsibilities and Rights.</b>	
4.1	Collegiality and loyalty, Managing conflict, Respect for authority	1
4.2	Collective bargaining, Confidentiality, Role of confidentiality in moral integrity, Conflicts of interest	2
4.3	Occupational crime, Professional rights, Employee right, IPR Discrimination	2
<b>5</b>	<b>Module 5- Global Ethical Issues.</b>	
5.1	Multinational Corporations, Environmental Ethics, Business Ethics, Computer Ethics	2
5.2	Role in Technological Development, Moral leadership	1
5.3	Engineers as Managers, Consulting Engineers, Engineers as Expert witnesses and advisors	2

COURSE CODE	COURSE NAME	CATEGORY	L	T	P	CREDITS
22MNC407	CONSTITUTION OF INDIA	MCN	2	0	0	--

**Preamble:**

The study of their own country constitution and studying the importance environment as well as understanding their own human rights help the students to concentrate on their day to day discipline. It also gives the knowledge and strength to face the society and people.

**Prerequisite:** Nil

**Course Outcomes:** After the completion of the course the student will be able to

<b>CO 1</b>	Explain the background of the present constitution of India and features.
<b>CO 2</b>	Utilize the fundamental rights and duties.
<b>CO 3</b>	Understand the working of the union executive, parliament and judiciary.
<b>CO 4</b>	Understand the working of the state executive, legislature and judiciary.
<b>CO 5</b>	Utilize the special provisions and statutory institutions.
<b>CO 6</b>	Show national and patriotic spirit as responsible citizens of the country

**Mapping of course outcomes with program outcomes**

	PO 1	PO 2	PO 3	PO 4	PO 5	PO 6	PO 7	PO 8	PO 9	PO 10	PO 11	PO 12
<b>CO 1</b>						2	2	2		2		
<b>CO 2</b>						3	3	3		3		
<b>CO 3</b>						3	2	3		3		
<b>CO 4</b>						3	2	3		3		
<b>CO 5</b>						3	2	3		3		
<b>CO 6</b>						3	3	3		2		

**Assessment Pattern**

Bloom's Category	Continuous Assessment Tests		End Semester Examination
	1	2	
Remember	20	20	40
Understand	20	20	40
Apply	10	10	20
Analyse			

Evaluate			
Create			

### Mark distribution

Total Marks	CIE	ESE	ESE Duration
150	50	100	3 hours

### Continuous Internal Evaluation Pattern:

Attendance	: 10 marks
Continuous Assessment Test (2 numbers)	: 25 marks
Assignment/Quiz/Course project	: 15 marks

**End Semester Examination Pattern:** There will be two parts; Part A and Part B. Part A contain 10 questions with 2 questions from each module, having 3 marks for each question. Students should answer all questions. Part B contains 2 questions from each module of which student should answer any one. Each question can have maximum 2 sub-divisions and carry 14 marks.

### Course Level Assessment Questions

#### Course Outcome 1 (CO1):

- 1 Discuss the historical background of the Indian constitution.
- 2 Explain the salient features of the Indian constitution.
- 3 Discuss the importance of preamble in the implementation of constitution.

#### Course Outcome 2 (CO2)

- 1 What are fundamental rights ? Examine each of them.
- 2 Examine the scope of freedom of speech and expression underlying the constitution.
- 3 The thumb impression of an accused is taken by the police against his will. He contends that this is a violation of his rights under Art 20(3) of the constitution. Decide.

#### Course Outcome 3(CO3):

- 1 Explain the powers of the President to suspend the fundamental rights during emergency.

2 Explain the salient features of appeal by special leave.

3. List the constitutional powers of President.

**Course Outcome 4 (CO4):**

1 Discuss the constitutional powers of Governor.

2 Examine the writ jurisdiction of High court.

3 Discuss the qualification and disqualification of membership of state legislature.

**Course Outcome 5 (CO5):**

1 Discuss the duties and powers of comptroller of auditor general.

2 Discuss the proclamation of emergency.

3 A state levies tax on motor vehicles used in the state, for the purpose of maintaining roads in the state. X challenges the levy of the tax on the ground that it violates the freedom of interstate commerce guaranteed under Art 301. Decide.

**Course Outcome 6 (CO6):**

1 Explain the advantages of citizenship.

2 List the important principles contained in the directive principles of state policy.

3 Discuss the various aspects contained in the preamble of the constitution

**Model Question paper**

**PART A**

(Answer all questions. Each question carries 3 marks)

1 Define and explain the term constitution.

2 Explain the need and importance of Preamble.

3 What is directive principle of state policy?

4 Define the State.

5 List the functions of Attorney general of India.



- 6 Explain the review power of Supreme court.
- 7 List the qualifications of Governor.
- 8 Explain the term and removal of Judges in High court.
- 9 Explain the powers of public service commission.
- 10 List three types of emergency under Indian constitution.

(10X3=30marks)

### **PART B**

(Answer on question from each module. Each question carries 14 marks)

#### **Module 1**

- 11 Discuss the various methods of acquiring Indian citizenship.
- 12 Examine the salient features of the Indian constitution.

#### **Module 2**

- 13 A high court passes a judgement against X. X desires to file a writ petition in the supreme court under Art32, on the ground that the judgement violates his fundamental rights. Advise him whether he can do so.
- 14 What is meant by directive principles of State policy? List the directives.

#### **Module3**

- 15 Describe the procedure of election and removal of the President of India.
- 16 Supreme court may in its discretion grant special leave to appeal. Examine the situation.

#### **Module 4**

- 17 Discuss the powers of Governor.
- 18 X filed a writ petition under Art 226 which was dismissed. Subsequently, he filed a writ petition under Art 32 of the constitution, seeking the same remedy. The Government argued that the writ petition should be dismissed, on the ground of res judicata. Decide.

#### **Module 5**

19 Examine the scope of the financial relations between the union and the states.

20 Discuss the effects of proclamation of emergency.

(14X5=70marks)

### Syllabus

**Module 1** Definition, historical back ground, features, preamble, territory, citizenship.

**Module 2** State, fundamental rights, directive principles, duties.

**Module 3** The machinery of the union government.

**Module 4** Government machinery in the states

**Module 5** The federal system, Statutory Institutions, miscellaneous provisions.

### Text Books

1 D D Basu, Introduction to the constitution of India, Lexis Nexis, New Delhi, 24e, 2019

2 PM Bhakshi, The constitution of India, Universal Law, 14e, 2017

### Reference Books

1 Ministry of law and justice, The constitution of India, Govt of India, New Delhi, 2019.

2 JN Pandey, The constitutional law of India, Central Law agency, Allahabad, 51e, 2019

3 MV Pylee, India's Constitution, S Chand and company, New Delhi, 16e, 2016

### Course Contents and Lecture Schedule

No	Topic	No. of Lectures
1	<b>Module 1</b>	
1.1	Definition of constitution, historical back ground, salient features of the constitution.	1
1.2	Preamble of the constitution, union and its territory.	1
1.3	Meaning of citizenship, types, termination of citizenship.	2
2	<b>Module 2</b>	
2.1	Definition of state, fundamental rights, general nature, classification, right to equality ,right to freedom , right against exploitation	2

2.2	Right to freedom of religion, cultural and educational rights, right to constitutional remedies. Protection in respect of conviction for offences.	2
2.3	Directive principles of state policy, classification of directives, fundamental duties.	2
3	<b>Module 3</b>	
3.1	The Union executive, the President, the vice President, the council of ministers, the Prime minister, Attorney-General, functions.	2
3.2	The parliament, composition, Rajya sabha, Lok sabha, qualification and disqualification of membership, functions of parliament.	2
3.3	Union judiciary, the supreme court, jurisdiction, appeal by special leave.	1
4	<b>Module 4</b>	
4.1	The State executive, the Governor, the council of ministers, the Chief minister, advocate general, union Territories.	2
4.2	The State Legislature, composition, qualification and disqualification of membership, functions.	2
4.3	The state judiciary, the high court, jurisdiction, writs jurisdiction.	1
5	<b>Module 5</b>	
5.1	Relations between the Union and the States, legislative relation, administrative relation, financial Relations, Inter State council, finance commission.	1
5.2	Emergency provision, freedom of trade commerce and inter course, comptroller and auditor general of India, public Services, public service commission, administrative Tribunals.	2
5.3	Official language, elections, special provisions relating to certain classes, amendment of the Constitution.	2

COURSE CODE	COURSE NAME	CATEGORY	L	T	P	CREDITS
22MEL408	FM & HM LAB	ES	0	0	3	2

**Preamble:**

This lab is mainly focussed to develop a platform where the students can enhance their engineering knowledge in the fluid mechanics domain by applying their theoretical knowledge acquired.

**Prerequisite:** MET203 Mechanics of Fluids

**Course Outcomes:**

After the completion of the course the student will be able to

<b>CO 1</b>	Determine the coefficient of discharge of flow measuring devices (notches, orifice meter and Venturi meter)
<b>CO 2</b>	Calibrate flow measuring devices (notches, orifice meter and Venturi meter)
<b>CO 3</b>	Evaluate the losses in pipes
<b>CO 4</b>	Determine the metacentric height and stability of floating bodies
<b>CO 5</b>	Determine the efficiency and plot the characteristic curves of different types of pumps and turbines

**Mapping of course outcomes with program outcomes**

	PO 1	PO 2	PO 3	PO 4	PO 5	PO 6	PO 7	PO 8	PO 9	PO 10	PO 11	PO 12
<b>CO 1</b>	2	1						2	3	2		2
<b>CO 2</b>	2	1						2	3	2		2
<b>CO 3</b>	2	1						2	3	2		2
<b>CO 4</b>	2	1						2	3	2		2
<b>CO 5</b>	2	1						2	3	2		2

**Assessment Pattern**

**Mark distribution**

Total Marks	CIE	ESE	ESE Duration
150	75	75	2.5 hours

**Continuous Internal Evaluation Pattern:**

Attendance	:	15 marks
Continuous Assessment	:	30 marks
Internal Test (Immediately before the second series test)	:	30 marks

**End Semester Examination Pattern:** The following guidelines should be followed regarding award of marks

(a) Preliminary work	:	15 Marks
(b) Implementing the work/Conducting the experiment	:	10 Marks
(c) Performance, result and inference (usage of equipments and trouble shooting)	:	25 Marks
(d) Viva voce	:	20 marks
(e) Record	:	5 Marks

**General instructions:**

Practical examination to be conducted immediately after the second series test covering entire syllabus given below. Evaluation is a serious process that is to be conducted under the equal responsibility of both the internal and external examiners. The number of candidates evaluated per day should not exceed 20. Students shall be allowed for the University examination only on submitting the duly certified record. The external examiner shall endorse the record.

A minimum of 10 experiments are to be performed.

## SYLLABUS

### LIST OF EXPERIMENTS

1. Determination of coefficient of discharge and calibration of Notches.
2. Determination of coefficient of discharge and calibration of Orifice meter.
3. Determination of coefficient of discharge and calibration of Venturi meter.
4. Determination of hydraulic coefficients of orifices.
5. Determination of Chezy's constant and Darcy's coefficient on pipe friction apparatus.
6. Determine the minor losses in pipe.
7. Experiments on hydraulic ram.
8. Reynolds experiment.
9. Bernoulli's experiment.
10. Determination of metacentric height and radius of gyration of floating bodies.
11. Performance test on positive displacement pumps.

12. Performance test on centrifugal pumps, determination of operating point and efficiency.
13. Performance test on gear pump.
14. Performance test on Impulse turbines.
15. Performance test on reaction turbines (Francis and Kaplan Turbines).
16. Speed variation test on Impulse turbine.
17. Determination of best guide vane opening for Reaction turbine.
18. Impact of jet.

### **Reference Books**

1. Yunus A. Cengel, John M. Cimbala; Fluid Mechanics- Fundamentals and Applications (in SI Units); McGraw Hill, 2010.
2. Bansal R.K, Fluid Mechanics and Hydraulic Machines (SI Units); Laxmi Publications, 2011.
3. Modi P.N and Seth S.M, "Hydraulics and Fluid Mechanics Including Hydraulic Machines" Standard Book House, New Delhi, 20th Edition, 2015
4. Graebel. W. P, "Engineering Fluid Mechanics", Taylor & Francis, Indian Reprint, 2011
5. Robert W. Fox, Alan T. McDonald, Philip J. Pritchard, "Fluid Mechanics and Machinery", John Wiley and sons, 2015.
6. J. Frabzini, 'Fluid Mechanics with Engineering Applications', McGraw Hill, 1997.

COURSE CODE	COURSE NAME	CATEGORY	L	T	P	CREDITS
22MEL409	MACHINE TOOLS LAB I	ES	0	0	3	2

**Preamble:**

1. To understand the parts of various machine tools and impart hands on experience on lathe, drilling, shaping, milling, slotting, grinding, tool and cutter grinding machines.
2. To develop knowledge and importance of metal cutting parameters such as feed, velocity and depth of cut etc on cutting force and surface roughness obtainable.
3. To develop fundamental knowledge on tool materials, cutting fluids and tool wear Mechanisms.
4. To apply knowledge of basic mathematics to calculate the machining parameters for different machining processes.
5. To study process parameters and practice on arc and gas welding technologies.
6. To gain knowledge on the structure, properties, heat treatment, testing and applications of ferrous and non ferrous metals.

**Prerequisite:** MET 204 - Manufacturing Process

**Course Outcomes** - At the end of the course students will be able to

<b>CO 1</b>	The students can operate different machine tools with understanding of work holders and operating principles to produce different part features to the desired quality.
<b>CO 2</b>	Apply cutting mechanics to metal machining based on cutting force and power consumption.
<b>CO 3</b>	Select appropriate machining processes and process parameters for different metals.
<b>CO 4</b>	Fabricate and assemble various metal components by welding and students will be able to visually examine their work and that of others for discontinuities and defects.
<b>CO 5</b>	Infer the changes in properties of steel on annealing, normalizing, hardening and tempering.

**Mapping of course outcomes with program outcomes (Minimum requirements)**

	PO 1	PO 2	PO 3	PO 4	PO 5	PO 6	PO 7	PO 8	PO 9	PO 10	PO 11	PO 12
<b>CO 1</b>	-	-	<b>3</b>	-	-	-	-	-	-	-	-	-
<b>CO 2</b>	-	<b>3</b>	-	-	-	-	-	-	-	-	-	-
<b>CO 3</b>	-	-	-	<b>2</b>	-	-	-	-	-	-	-	-
<b>CO 4</b>	<b>2</b>	-	-	-	-	-	-	-	-	-	-	-
<b>CO 5</b>	-	-	-	-	<b>2</b>	-	-	-	-	-	-	-

### Assessment Pattern

Bloom's taxonomy	Continuous Assessment Tests	
	Test 1 (Marks)	Test 2 (Marks)
Remember	20	20
Understand	10	10
Apply	30	30
Analyse	20	20
Evaluate	10	10
Create	10	10

### Mark distribution

Total Marks	CIE marks	ESE marks	ESE duration
150	75	75	2.5 Hours

### Continuous Internal Evaluation (CIE) Pattern:

Attendance	15 marks
Regular class work/ /Laboratory Record and Class Performance	30 marks
Continuous Assessment Test/s	30 marks
The student's assessment, continuous evaluation, record bonafides, awarding of sessional marks, oral examination etc. should be carried out only by the assistant professor or above. Any two experiments mentioned in part - B, and any eight experiments in part A and total of minimum of ten experiments are to be performed.	

### End semester examination pattern

The Practical Examination will comprise of three hours. Oral examination should be conducted and distribution of marks will be decided by the examiners.

### Conduct of University Practical Examinations

The Principals of the concerned Engineering Colleges with the help of the Chairmen/Chairperson will conduct the practical examination with the approval from the University and bonafide work / laboratory record, hall ticket, identity card issued by college are mandatory for appearing practical University examinations. To conduct practical examination, an external examiner and an internal examiner should be appointed by the University.



**END SEMESTER EXAMINATION  
MODEL QUESTION PAPER**

**Maximum Marks : 75**

**Duration: 2.5 hours**

1. To machine the hexagonal head and the slot shown in the sketch on the specimen and measure the tool wear using toolmaker's microscope.

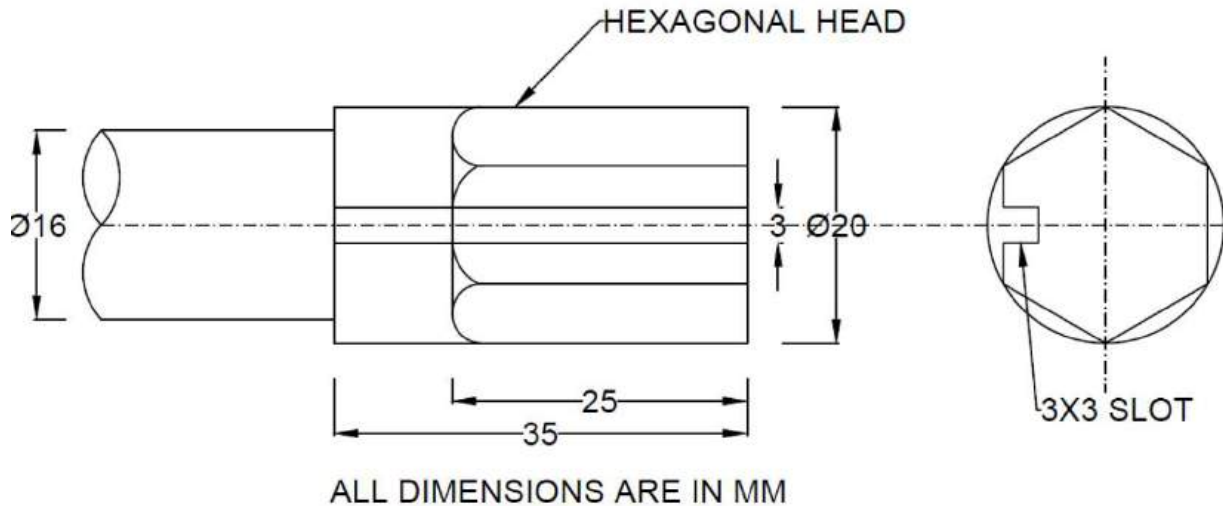

**OR**

2. To drill, file, as shown in the sketch, ream and tap holes on the mild steel plate and measure the tool wear using toolmaker's microscope.

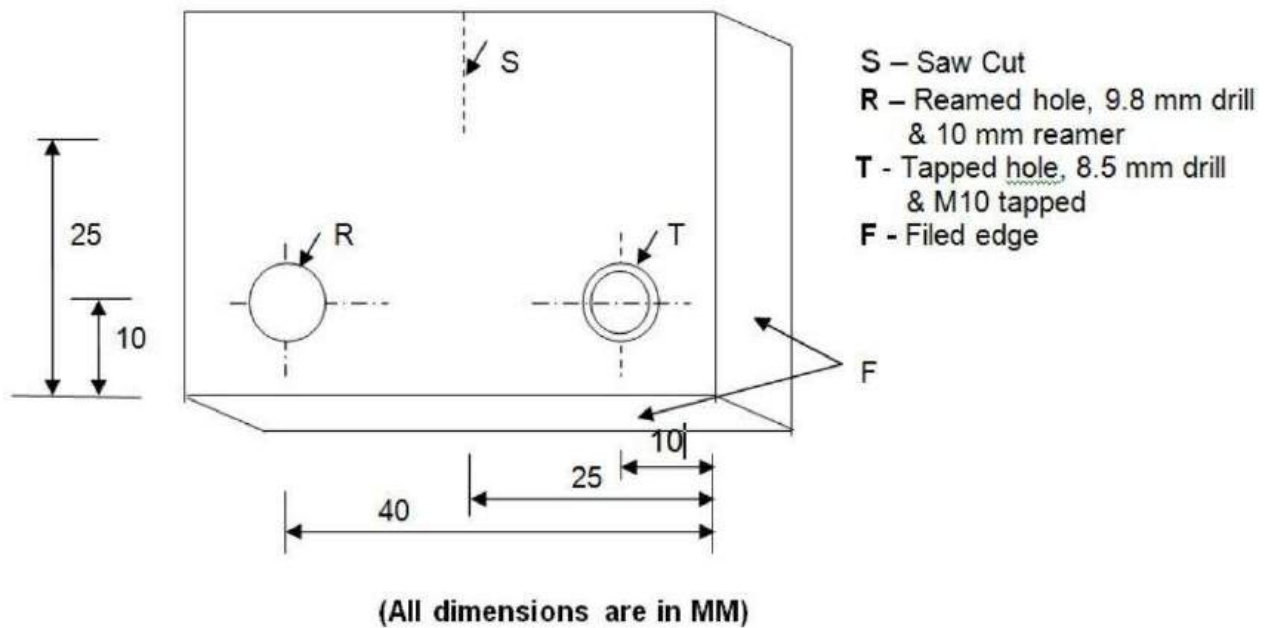

**OR**

3. To make the part shown in the sketch from a mild steel rod on a Lathe and measure the tool flank wear using toolmaker's microscope.

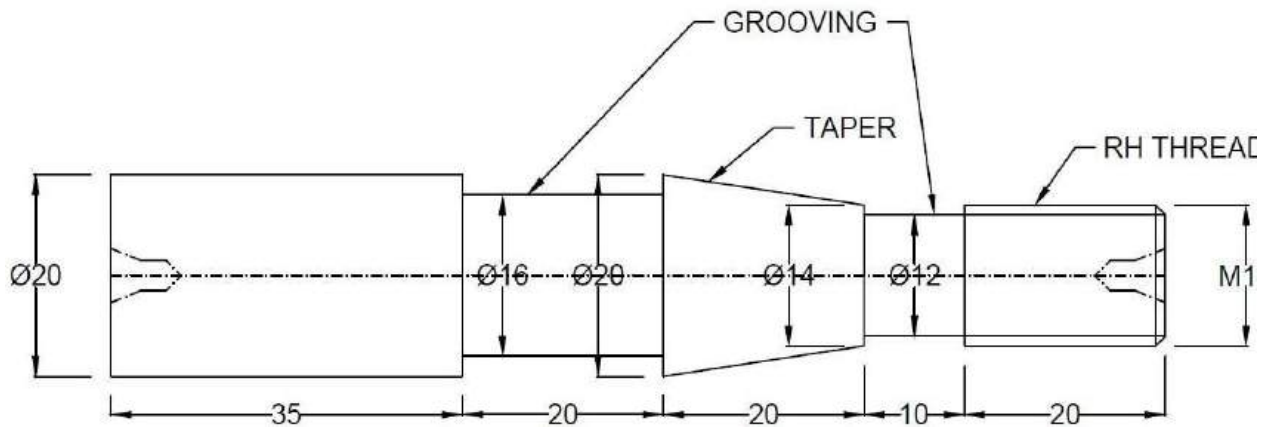

OR

4. Prepare a metallurgical sample and determine the grain size using a optical microscope.

OR

5. To prepare a butt joint with mild steel strip using suitable welding technique and infer on the welded joint.

OR

6. To make the part shown in the sketch from a mild steel rod on a Lathe and measure the tool flank wear using toolmaker's microscope.

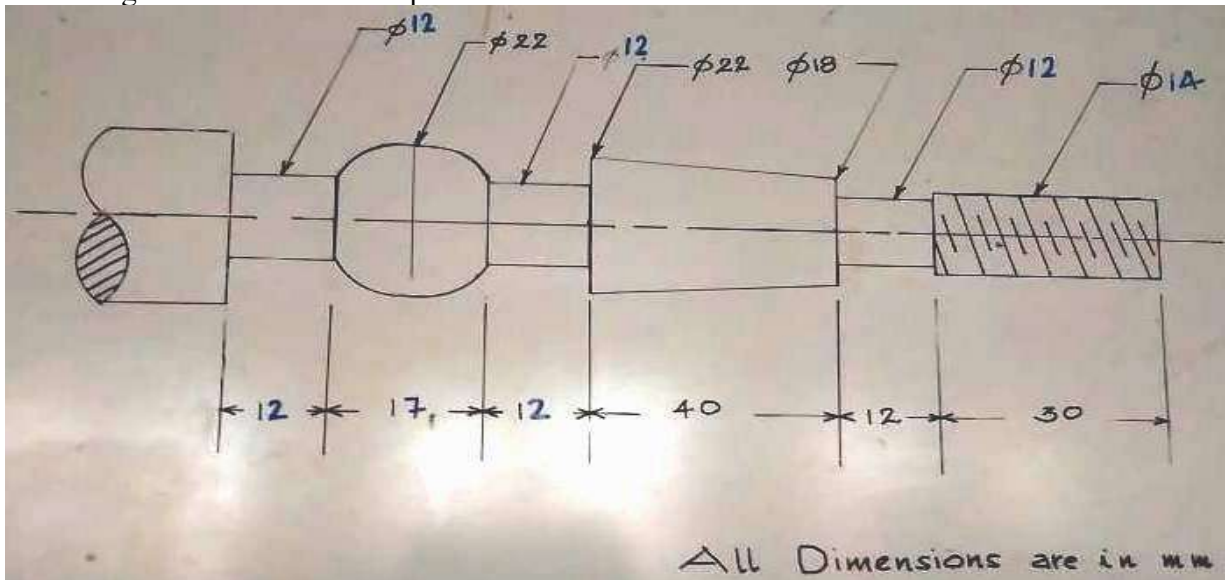

## SYLLABUS

### PART - A

Safety precautions in machine shop - Exercises on machine tools: turning, knurling, drilling, boring, reaming, trepanning, milling, hobbing, planning, shaping, slotting, broaching, grinding, lapping, honing etc. - Welding practice.

### PART - B

Metallurgy, heat treatment and testing.

#### Text Books:

1. Acherkan N. S. "Machine Tool", Vol. I, II, III and IV, MIR Publications.
2. HMT, Production Technology, Tata McGraw Hill.
3. W. A. J. Chapman, Workshop Technology Part I, ELBS & Edward Arnold Publishers.

#### Course content and drawing schedules.

	<b>List of Experiments</b> <b>A minimum of ten experiments are to be carried out</b>	<b>Course outcomes</b>	<b>No. of hours</b>
<b>Experiments</b>	<b>PART -A</b> <b>(minimum eight experiments)</b>		
<b>1</b>	<p><b>Centre Lathe</b></p> <p>Study of lathe tools: - tool materials - selection of tool for different operations - tool nomenclature and attributes of each tool angles on cutting processes – effect of nose radius, side cutting edge angle, end cutting edge angle and feed on surface roughness obtainable – tool grinding.</p> <ul style="list-style-type: none"> <li>• Study the different methods used to observe the work-piece is precisely fixed on lathe.</li> <li>• Study the optimum aspect ratio of work-piece to avoid vibration and wobbling during turning.</li> <li>• Machine tool alignment test on lathe.</li> <li>• Re-sharpening of turning tool to specific geometry</li> </ul>	CO 1	3
<b>2,3,4,5,6</b>	<p><b>Exercises on centre lathe:-</b> Facing, plain turning, step turning and parting – groove cutting, knurling and chamfering - form turning and taper turning – eccentric turning, multi-start thread, square thread and internal thread etc.</p>	CO 1 CO 2	3
	<p><b>Exercises on lathe:-</b> Measurement of cutting forces in turning process and correlate the surface roughness obtainable by varying feed, speed, feed, nose radius, side and end cutting edge angles.</p>		6

7	Measurement of cutting temperature and tool life in turning and machine tool alignment test on lathe machine.	CO 2	3
86	<b>Exercises on Drilling machine</b> <ul style="list-style-type: none"> <li>• <b>Exercises on drilling machine:</b> - drilling, boring, reaming, tapping and counter sinking etc.</li> </ul>	CO 1 CO 2	3
	<ul style="list-style-type: none"> <li>• <b>Exercises on drilling machine:</b> - Measurement of cutting forces in drilling process and correlate with process parameters.</li> </ul>		
9	<b>Exercises on Shaping machine</b> <ul style="list-style-type: none"> <li>• Exercises on shaping machine: - flat surfaces, grooves and key ways.</li> </ul>	CO 2	3
	<b>Exercises on Slotting machine</b> <ul style="list-style-type: none"> <li>• Exercises on slotting machine: - flat surfaces, grooves and key ways.</li> </ul>		
10	<b>Planing and Broaching machine</b> Study and demonstration of broaching and hobbing machine. <ul style="list-style-type: none"> <li>• Exercises on planing machine</li> </ul>	CO 1	3
11	<b>Exercises on Grinding machine</b> <ul style="list-style-type: none"> <li>• Exercise on surface grinding, cylindrical grinding and tool grinding etc.</li> <li>• Measurement of cutting forces and roughness in grinding process and correlate with process parameters.</li> <li>• Study and demonstration of lapping and honing machines.</li> </ul>	CO 1	3
12	<b>Exercises on Welding machine</b> <ul style="list-style-type: none"> <li>• Exercises on arc and gas welding: - butt welding and lap welding of M.S. sheets.</li> </ul>	CO 4	3
	<b>PART - B - Metallurgy (minimum two experiments)</b>		
13	<ul style="list-style-type: none"> <li>• <b>Specimen preparation</b>, etching &amp; microscopic study of Steel, Cast iron and Brass and grain size measurement.</li> </ul>	CO 5	6
14	<ul style="list-style-type: none"> <li>• <b>Heat treatment study:</b>—Effect on mechanical properties and microstructure of ferrous and non ferrous metals.</li> </ul>	CO 5	6
	<ul style="list-style-type: none"> <li>• Studies of various quenching mediums, Carryout heat treatments on steel based on ASM handbook vol.4 and observe the hardness obtained.</li> </ul>		

**SEMESTER -4**  
**MINOR**

COURSE CODE	COURSE NAME	CATEGORY	L	T	P	CREDITS
22MEMR410.1	THEORY OF MACHINES	MR	3	1	0	4

**Preamble:**

Goal of this course is to expose the students to the fundamentals of kinematics of mechanisms, design of cams, theory and analysis of gears, gear trains, clutches, brakes. The students will also be exposed to velocity and acceleration analysis of different mechanisms. It provides the knowledge on balancing of rotating and reciprocating masses, Gyroscopes, Energy fluctuation in Machines.

**Prerequisite: Nil**

**Course Outcomes:** After the completion of the course the student will be able to

<b>CO 1</b>	Interpret basic principles of mechanisms and machines and Analyse a given mechanism based on velocity and acceleration. List the basic selection requirements of different types of mechanical clutches.
<b>CO 2</b>	Describe the theories of gears and gear trains. List the basic selection requirements of different types of mechanical brakes.
<b>CO 3</b>	Develop the profile of CAMs as per the requirements and to understand cam profile.
<b>CO 4</b>	Explain the dynamic balancing of revolving and reciprocating masses. Describe the fundamentals of gyroscope and its application.
<b>CO 5</b>	Analyse the performance of governors and flywheels.

**Mapping of course outcomes with program outcomes**

	PO 1	PO 2	PO 3	PO 4	PO 5	PO 6	PO 7	PO 8	PO 9	PO 10	PO 11	PO 12
<b>CO 1</b>	3	3	2	2		3						2
<b>CO 2</b>	3	3	2	2		3						2
<b>CO 3</b>	3	3	2	2		3						2
<b>CO 4</b>	3	3	3	2		1						1
<b>CO 5</b>	3	3	3	3		1						3

**Assessment Pattern**

Bloom's Category	Continuous Assessment Tests		End Semester Examination
	1	2	
Remember			
Understand	30	40	80
Apply		10	10
Analyse	20		10
Evaluate			
Create			

### Mark distribution

Total Marks	CIE	ESE	ESE Duration
150	50	100	3 hours

### Continuous Internal Evaluation Pattern:

Attendance	: 10 marks
Continuous Assessment Test (2 numbers)	: 25 marks
Assignment/Quiz/Course project	: 15 marks

**End Semester Examination Pattern:** There will be two parts; Part A and Part B. Part A contain 10 questions with 2 questions from each module, having 3 marks for each question. Students should answer all questions. Part B contains 2 questions from each module of which student should answer any one. Each question can have maximum 2 sub-divisions and carry 14 marks.

## COURSE LEVEL ASSESSMENT QUESTIONS

**Course Outcome 1 (CO1):** *Interpret basic principles of mechanisms and machines. Analyse a given mechanism based on velocity and acceleration. List the basic selection requirements of different types of mechanical clutches.*

1. Explain the inversions of a four bar mechanism.
2. Explain with neat sketches, the working of single plate clutch.
3. The crank of a slider crank mechanism rotates clockwise at a constant speed of 300 r.p.m. The crank is 150 mm and the connecting rod is 600 mm long. Determine: 1. Linear velocity and acceleration of the midpoint of the connecting rod, and 2. angular velocity and angular acceleration of the connecting rod, at a crank angle of  $45^\circ$  from inner dead centre position

**Course Outcome 2 (CO2)** *Describe the theories of gears and gear trains. List the basic selection requirements of different types of mechanical brakes.*

1. State and prove the law of gearing
2. In an epicyclic gear train, an arm carries two gears A and B having 36 and 45 teeth respectively. If the arm rotates at 150 rpm in the anticlockwise direction about the centre of the gear A which is fixed, determine the speed of gear B. If the gear A instead of being fixed makes 300 rpm in the clockwise direction, what will be the speed of gear B?
3. Discuss the various types of the brakes.

**Course Outcome 3 (CO3):** *Develop the profile of CAMs as per the requirements and and to understand cam profile.*

1. Explain the different classifications of cam and followers.
2. Draw the displacement, velocity and acceleration diagrams when the follower moves in SHM.
3. A cam with 30 mm as minimum diameter is rotating clockwise at a uniform speed of 1200 r.p.m. and has to give the following motion to a roller follower 10 mm in diameter:
  - a) Follower to complete outward stroke of 25 mm during  $120^\circ$  of cam rotation with equal uniform acceleration and retardation;
  - b) (b) Follower to dwell for  $60^\circ$  of cam rotation;
  - c) (c) Follower to return to its initial position during  $90^\circ$  of cam rotation with equal uniform acceleration and retardation;
  - d) (d) Follower to dwell for the remaining  $90^\circ$  of cam rotation.

Draw the cam profile if the axis of the roller follower passes through the axis of the cam.



**Course Outcome 4 (CO4):** *Explain the static and dynamic balancing of revolving and reciprocating masses. Describe the fundamentals of gyroscope and its application*

1. Four masses  $m_1$ ,  $m_2$ ,  $m_3$  and  $m_4$  are 200 kg, 300 kg, 240 kg and 260 kg respectively. The corresponding radii of rotation are 0.2 m, 0.15 m, 0.25 m and 0.3 m respectively and the angles between successive masses are  $45^\circ$ ,  $75^\circ$  and  $135^\circ$ . Find the position and magnitude of the balance mass required, if its radius of rotation is 0.2 m.
2. Explain with neat sketches, the terms Swaying Couple and Hammer Blow.
3. A ship propelled by a turbine rotor which has a mass of 5000 kg and a speed of 2100 r.p.m. The rotor has a radius of gyration of 0.5 m and rotates in a clockwise direction when viewed from the stern. Find the gyroscopic effects in the following conditions:
  - a. The ship sails at a speed of 30 km/h and steers to the left in a curve having 60 m radius.
  - b. The ship pitches 6 degree above and 6 degree below the horizontal position. The bow is descending with its maximum velocity. The motion due to pitching is simple harmonic and the periodic time is 20 seconds.
  - c. The ship rolls and at a certain instant it has an angular velocity of 0.03 rad/s clockwise when viewed from stern.

Determine also the maximum angular acceleration during pitching. Explain how the direction of motion due to gyroscopic effect is determined in each case.

**Course Outcome 5 (CO5):** *Analyse the performance of governors and flywheels.*

1. The turning moment diagram for a petrol engine is drawn to the following scales : Turning moment, 1 mm = 5 N-m ; crank angle, 1 mm =  $1^\circ$ . The turning moment diagram repeats itself at every half revolution of the engine and the areas above and below the mean turning moment line taken in order are 295, 685, 40, 340, 960, 270 mm<sup>2</sup>. The rotating parts are equivalent to a mass of 36 kg at a radius of gyration of 150 mm. Determine the coefficient of fluctuation of speed when the engine runs at 1800 r.p.m
2. Explain the different types of governors.
3. The arms of a Porter governor are each 250 mm long and pivoted on the governor axis. The mass of each ball is 5 kg and the mass of the central sleeve is 30 kg. The radius of rotation of the balls is 150 mm when the sleeve begins to rise and reaches a value of 200 mm for maximum speed. Determine the speed range of the governor. If the friction at the sleeve is equivalent of 20 N of load at the sleeve, determine how the speed range is modified.

# SYLLABUS

**Module 1:** Kinematics - Links, mechanism, Degrees of freedom, Grashoff's law. Four-bar chain, Slider crank chain- Inversions and practical applications. Velocity and acceleration diagrams of simple mechanisms. Coriolis acceleration (Theory only). Friction clutch - Pressure and wear theories, pivot and collar friction, Single and multiple disc clutches.

**Module 2:** Gear – Classification of gears- Gear terminology- Law of gearing, Gear trains - Simple, compound gear trains and epicyclic gear trains. Brakes - Block and band brakes, self-energizing and self-locking in braking.

**Module 3:** Cams- Types of cams, cam profiles for knife edged and roller followers with and without offsets for SHM, constant acceleration-deceleration, and constant velocity

**Module 4:** Static and dynamic balancing of rotating mass- Single and several masses in different planes. Balancing of reciprocating mass. Gyroscope –Gyroscopic torque, gyroscopic stabilization of ships and aeroplanes.

**Module 5:** Governors - Types of governors- simple watt governor - Porter governor- Theory of Proell governor - Isochronism, hunting, sensitivity and stability. Flywheel - Turning moment diagrams, fluctuation of energy

## Text Books

1. Ballaney P.L. Theory of Machines, Khanna Publishers,1994
2. S. S. Rattan, Theory of Machines, Tata McGraw Hill, 2009
3. V. P. Singh, Theory of Machines, Dhanpat Rai,2013

## Reference Books

1. C. E. Wilson, P. Sadler, Kinematics and Dynamics of Machinery, Pearson Education,2005
2. D. H. Myszka, Machines and Mechanisms Applied Kinematic Analysis, Pearson Education,2013
3. G. Erdman, G. N. Sandor, Mechanism Design: Analysis and synthesis Vol I & II, Prentice Hall of India,1984.
4. Ghosh, A. K. Malik, Theory of Mechanisms and Machines, Affiliated East West Press,1988
5. J. E. Shigley, J. J. Uicker, Theory of Machines and Mechanisms, McGraw Hill,2010
6. Holowenko, Dynamics of Machinery, John Wiley, 1995

## COURSE PLAN

No	Topic	No. of Lectures
<b>1</b>	<b>Module 1 (CO1)</b>	
1.1	Introduction to link, constrained motions, mechanism, machine	1
1.2	Degrees of freedom, Problem, Grashof's law	1
1.3	Inversion – Four Bar chain – Single Slider Chain – Practical Applications	2
1.4	Velocity Analysis – I Centre Method – Relative Velocity Method	2
1.5	Acceleration Analysis - Four Bar Mechanism – Single Slider Chain	2
1.6	Coriolis Component of Acceleration –Quick Return Mechanisms	2
1.7	Clutches – Theories - Classifications	1
<b>2</b>	<b>Module 2 (CO2)</b>	
2.1	Gear – Classifications – Terminology – Law of Gearing – Velocity of Sliding – Interference - Problems	3
2.2	Gear Train –Classifications - Problems on Epi cyclic gear trains	3
2.3	Brake – Theory – Classifications	2
<b>3</b>	<b>Module 3 (CO3)</b>	
3.1	Cam – Introduction - Classifications	1
3.2	Velocity and Acceleration Diagrams – Uniform Velocity – Uniform Acceleration and Deceleration – SHM – Calculations	2
3.3	Construction of Cam Profile	4
<b>4</b>	<b>Module 4 (CO4)</b>	
4.1	Static and dynamic balancing of rotating masses –Single and several masses in different planes	2
4.2	Balancing of reciprocating masses	3
4.3	Gyroscope – Introduction – Stabilization of Ships	2
4.4	Stabilization of Air Planes	2
<b>5</b>	<b>Module 5 (CO5)</b>	
5.1	Governors – Introduction –Classifications	2
5.2	Analytical Problems	2
5.3	Hunting – Sensitivity – Isochronism -Stability	2
5.4	Flywheels – Turning Moment Diagrams –Fluctuation of Energy	2
5.5	Analytical Problems	2

**MODEL QUESTION PAPER**  
**FIFTH SEMESTER B.TECH DEGREE EXAMINATION**  
**Course Code : MET282**  
**Course Name : THEORY OF MACHINES**

Max. Marks : 100

Duration : 3 Hours

**PART – A**  
**(ANSWER ALL QUESTIONS, EACH QUESTION CARRIES 3 MARKS)**

1. Write down the Kutzbach criterion of movability of plane mechanisms. Derive the Grubler's equation from it.
2. Explain the types of constrained motions with neat sketches.
3. With a neat sketch prove the common normal at the point of contact between a pair of teeth must always pass through the pitch point.
4. Explain the terms : (i) Module, (ii) Pressure angle, and (iii) Addendum.
5. Explain the different classifications of followers.
6. Define the following terms as applied to cam with a neat sketch :-(a) Base circle, (b) Pitch circle, (c) Pressure angle
7. Why reciprocating masses is cannot be completely balanced by revolving mass?
8. Derive the formula for the magnitude of gyroscopic couple.
9. Write down the differences between a gyroscope and a flywheel.
10. Explain the term hunting and isochronism.

**PART – B**  
**(ANSWER ONE FULL QUESTION FROM EACH MODULE)**

**MODULE – 1**

11. The dimensions and configuration of the four bar mechanism, shown in Figure, are as follows :  
 $P_1A = 300 \text{ mm}$ ;  $P_2B = 360 \text{ mm}$ ;  $AB = 360 \text{ mm}$ , and  $P_1P_2 = 600 \text{ mm}$ . The angle  $AP_1P_2 = 60^\circ$ . The crank  $P_1A$  has an angular velocity of  $10 \text{ rad/s}$  and an angular acceleration of  $30 \text{ rad/s}^2$ , both clockwise. Determine the angular velocities and angular accelerations of  $P_2B$ , and  $AB$  and the velocity and acceleration of the joint  $B$ . (14 marks)

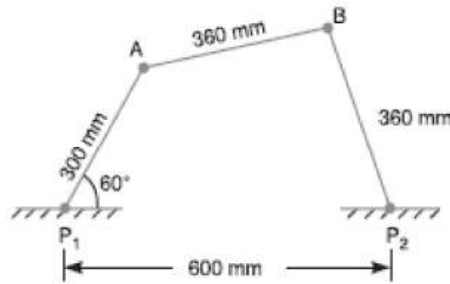

OR

12. a) With neat sketches explain the inversions of a four bar mechanism. (7 marks)  
 b) Derive the equation for the Coriolis's component of acceleration. (7 marks)

**MODULE – 2**

13. An internal wheel B with 80 teeth is keyed to a shaft F. A fixed internal wheel C with 82 teeth is concentric with B. A compound wheel D-E gears with the two internal wheels; D has 28 teeth and gears with C while E gears with B. The compound wheels revolve freely on a pin which projects from a disc keyed to a shaft A co-axial with F. If the wheels have the same pitch and the shaft A makes  $800 \text{ r.p.m.}$ , what is the speed of the shaft F? Sketch the arrangement. (14 marks)

OR

14. a) What do you mean by a self-energizing brake and self-locking brake. (4 Marks)  
 b) A simple band brake operates on a drum of diameter  $600 \text{ mm}$  that is running at a speed of  $200 \text{ rpm}$ . The coefficient of friction is  $0.3$ . The brake band has an angle of contact of  $270^\circ$ . One end of it is fastened to a fixed pin and the other end to the brake arm  $125 \text{ mm}$  and is placed perpendicular to the line bisecting the angle of contact.
- i. What is the effort necessary at the end of brake arm to stop the wheel if  $30 \text{ kW}$  power is absorbed? What is the direction of rotation of drum for minimum pull?
  - ii. What is the width of steel band required for this brake if the maximum tensile stress is not to exceed  $50 \text{ N/mm}^2$  and the thickness of band is  $2.5 \text{ mm}$ .

(10 marks)

### MODULE – 3

15. A cam rotating clockwise at a uniform speed of 1000 r.p.m. is required to give a roller follower the motion defined below : 1. Follower to move outwards through 50 mm during  $120^\circ$  of cam rotation, 2. Follower to dwell for next  $60^\circ$  of cam rotation, 3. Follower to return to its starting position during next  $90^\circ$  of cam rotation, 4. Follower to dwell for the rest of the cam rotation. The minimum radius of the cam is 50 mm and the diameter of roller is 10 mm. The line of stroke of the follower is off-set by 20 mm from the axis of the cam shaft. If the displacement of the follower takes place with uniform and equal acceleration and retardation on both the outward and return strokes, draw profile of the cam. (14 marks)

OR

16. From the following data, draw the profile of a cam in which the follower moves with simple harmonic motion during ascent while it moves with uniformly accelerated motion during descent : Least radius of cam = 50 mm ; Angle of ascent =  $48^\circ$  ; Angle of dwell between ascent and descent =  $42^\circ$  ; Angle of descent =  $60^\circ$  ; Lift of follower = 40 mm ; Diameter of roller = 30 mm ; Distance between the line of action of follower and the axis of cam = 20 mm. If the cam rotates at 360 r.p.m. anticlockwise, find the maximum velocity and acceleration of the follower during descent. (14 marks)

### MODULE – 4

17. a) A shaft carries four masses A, B, C and D of magnitude 200 kg, 300 kg, 400 kg and 200 kg respectively and revolving at radii 80 mm, 70 mm, 60 mm and 80 mm in planes measured from A at 300 mm, 400 mm and 700 mm. The angles between the cranks measured anticlockwise are A to B  $45^\circ$ , B to C  $70^\circ$  and C to D  $120^\circ$ . The balancing masses are to be placed in planes X and Y. The distance between the planes A and X is 100 mm, between X and Y is 400 mm and between Y and D is 200 mm. If the balancing masses revolve at a radius of 100 mm, find their magnitudes and angular positions. (10 marks)
- b) Explain the term swaying couple and hammer blow (4 marks)

OR

18. A ship propelled by a turbine rotor which has a mass of 5000 kg and a speed of 2100 r.p.m. The rotor has a radius of gyration of 0.5 m and rotates in a clockwise direction when viewed from the stern. Find the gyroscopic effects in the following conditions: 1. The ship sails at a speed of 30 km/h and steers to the left in a curve having 60 m radius. 2. The ship pitches 6 degree above and 6 degree below the horizontal position. The bow is descending with its maximum velocity. The motion due to pitching is simple harmonic and the periodic time is 20 seconds. 3. The ship rolls and at a certain instant it has an angular velocity of 0.03 rad/s clockwise when viewed from stern. Determine also the maximum angular acceleration during pitching. Explain how the direction of motion due to gyroscopic effect is determined in each case. (14 marks)

## MODULE – 5

19. a) A Porter governor has all four arms 250 mm long. The upper arms are attached on the axis of rotation and the lower arms are attached to the sleeve at a distance of 30 mm from the axis. The mass of each ball is 5 kg and the sleeve has a mass of 50 kg. The extreme radii of rotation are 150 mm and 200 mm. Determine the range of speed of the governor. (10 marks)
- b) What is stability of a governor? How does it differ from sensitiveness? (4marks)

OR

20. A three cylinder single acting engine has its cranks set equally at  $120^\circ$  and it runs at 600 r.p.m. The torque-crank angle diagram for each cycle is a triangle for the power stroke with a maximum torque of 90 N-m at  $60^\circ$  from dead centre of corresponding crank. The torque on the return stroke is sensibly zero. Determine : 1. power developed. 2. coefficient of fluctuation of speed, if the mass of the flywheel is 12 kg and has a radius of gyration of 80 mm, 3. coefficient of fluctuation of energy, and 4. maximum angular acceleration of the flywheel. (14 marks)

COURSE CODE	COURSE NAME	CATEGORY	L	T	P	CREDITS
22MEMR410.2	THERMODYNAMICS	MR	3	1	0	4

**Preamble:**

Thermodynamics is the study of energy. Without energy life cannot exist. Activities from breathing to the launching of rockets involves energy transactions and are subject to thermodynamic analysis. Engineering devices like engines, turbines, refrigeration and air conditioning systems, propulsion systems etc., work on energy transformations and must be analysed using principles of thermodynamics. So, a thorough knowledge of thermodynamic concepts is essential for a mechanical engineer. This course offers an introduction to the basic concepts and laws of thermodynamics.

**Prerequisite:** NIL

**Course Outcomes:**

After completion of the course the student will be able to

CO1	Understand basic concepts and laws of thermodynamics
CO2	Conduct first law analysis of open and closed systems
CO3	Determine entropy changes associated with different processes
CO4	Understand the application and limitations of the ideal gas equation of state
CO5	Determine change in properties of pure substances during phase change processes
CO6	Evaluate properties of ideal gas mixtures

**Mapping of course outcomes with program outcomes**

	PO1	PO2	PO3	PO4	PO5	PO6	PO7	PO8	PO9	PO10	PO11	PO12
CO1	2	2										2
CO2	2	2	1	1								1
CO3	3	3	2	2								1
CO4	2	2	2	2								1
CO5	3	3	2	1								1
CO6	3	3	2	2								1

**Assessment Pattern**

Blooms Category	CA			ESA
	Assignment	Test - 1	Test - 2	
Remember	25	20	20	10
Understand	25	40	40	20
Apply	25	40	40	70
Analyse	25			
Evaluate				
Create				



**Continuous Internal Evaluation Pattern:**

Attendance : 10 marks

Continuous Assessment Test (2 numbers) : 25 marks

Assignment/Quiz/Course project : 15 marks

**Mark distribution & Duration of Examination :**

Total Marks	CA	ESE	ESE Duration
150	50	100	3 Hours

**End semester pattern:**

There will be two parts; Part A and Part B. Part A contain 10 questions with 2 questions from each module, having 3 marks for each question. Students should answer all questions. Part B contains 2 questions from each module of which student should answer any one. Each question can have maximum 2 sub-divisions and carry 14 marks.

## COURSE LEVEL ASSESSMENT QUESTIONS

**Course Outcome 1**

1. Discuss the limitations of first law of thermodynamics.
2. Second law of thermodynamics is often called a directional law . Why?
3. Explain Joule-Kelvin effect. What is the significance of the inversion curve ?

**Course Outcome 2**

1. A mass of 2.4 kg of air at 150 kPa and 12°C is contained in a gas – tight, frictionless piston – cylinder device. The air is now compressed to a final pressure of 600 kPa . During this process, heat is transferred from the air such that the temperature inside the cylinder remains constant. Calculate the work input during this process.
2. Carbon dioxide enters an adiabatic nozzle steadily at 1 MPa and 500°C with a mass flow rate of 600 kg/hr and leaves at 100 kPa and 450 m/s. The inlet area of the nozzle is 40 cm<sup>2</sup>. Determine (a) the inlet velocity and (b) the exit temperature
3. Water is being heated in a closed pan on top of a range while being stirred by a paddle – wheel. During the process, 30 kJ of heat is transferred to the water and 5 kJ of heat is lost to the surrounding air. The paddle – wheel work amounts to 500 N-m. Determine the final energy of the system, if its initial energy is 10 kJ.

**Course Outcome 3**

1. An adiabatic vessel contains 2 kg of water at 25°C. A paddle – wheel work transfer, the temperature of water is increased to 30°C. If the specific heat of water is assumed to be constant at 4.186 kJ/kg.K, find the entropy change of the universe.

2. Two kilograms of water at 80°C is mixed adiabatically with 3 kg of water at 30°C in a constant pressure process at 1 atm. Find the increase in entropy of the total mass of water due to the mixing process.

3. An iron block of unknown mass at 85°C is dropped into an insulated tank that contains 0.1 m<sup>3</sup> of water at 20°C. At the same time a paddle-wheel driven by a 200 W motor is activated to stir the water. Thermal equilibrium is established after 20 minutes when the final temperature is 24°C. Determine the mass of the iron block and the entropy generated during this process.

#### Course Outcome 4

1. Discuss the limitations of ideal gas equation.
2. Discuss law of corresponding states and its role in the construction of compressibility chart.
3. A rigid tank contains 2 kmol of N<sub>2</sub> and 6 kmol of CH<sub>4</sub> gases at 200 K and 12 MPa. Estimate the volume of the tank, using (a) ideal gas equation of state (b) the compressibility chart and Amagat's law

#### Course Outcome 5

1. Steam is throttled from 3 MPa and 600°C to 2.5 MPa. Determine the temperature of the steam at the end of the throttling process.
2. Determine the change in specific volume, specific enthalpy and quality of steam as saturated steam at 15 bar expands isentropically to 1 bar. Use steam tables
3. Estimate the enthalpy of vapourization of steam at 500 kPa, using the Clapeyron equation and compare it with the tabulated value

#### Course Outcome 6

1. A gaseous mixture contains, by volume, 21% nitrogen, 50% hydrogen and 29% carbon dioxide. Calculate the molecular weight of the mixture, the characteristic gas constant of the mixture and the value of the reversible adiabatic expansion index -  $\gamma$ . At 10°C, the  $C_p$  values of nitrogen, hydrogen and carbon dioxide are 1.039, 14.235 and 0.828 kJ/kg.K respectively.
2. A mixture of 2 kmol of CO<sub>2</sub> and 3 kmol of air is contained in a tank at 199 kPa and 20°C. Treating air to be a mixture of 79% N<sub>2</sub> and 21% O<sub>2</sub> by volume, calculate (a) the individual mass of CO<sub>2</sub>, N<sub>2</sub> and O<sub>2</sub>, (b) the percentage content of carbon by mass in the mixture and (c) the molar mass, characteristic gas constant and the specific volume of the mixture
3. A gas mixture in an engine cylinder has 12% CO<sub>2</sub>, 11.5% O<sub>2</sub> and 76.5% N<sub>2</sub> by volume. The mixture at 1000°C expands reversibly, according to the law  $PV^{1.25} = \text{constant}$ , to 7 times its initial volume. Determine the work transfer and heat transfer per unit mass of the mixture.

# SYLLABUS

**Module 1:** Role of Thermodynamics and its applications in Engineering and Science –Basic Concepts Macroscopic and Microscopic viewpoints, Concept of Continuum, Thermodynamic System and Control Volume, Surrounding, Boundaries, Types of Systems, Universe, Thermodynamic properties, Process, Cycle, Thermodynamic Equilibrium, Quasi – static Process, State, Point and Path function. Zeroth Law of Thermodynamics, Measurement of Temperature, reference Points, Temperature Scales.

**Module 2:** Energy - Work - Pdv work and other types of work transfer, free expansion work, heat and heat capacity. Joule's Experiment- First law of Thermodynamics - First law applied to Non flow Process- Enthalpy- specific heats- PMM1, First law applied to Flow Process, Mass and Energy balance in simple steady flow process. Applications of SFEE, Limitations of the First Law.

**Module 3:** Second Law of Thermodynamics, Thermal Reservoir, Heat Engine, Heat pump – Kelvin-Planck and Clausius Statements, Equivalence of two statements, Reversibility, Irreversible Process, Causes of Irreversibility, PMM2, Carnot's theorem and its corollaries, Absolute Thermodynamic Temperature scale. Clausius Inequality, Entropy- Entropy changes in various thermodynamic processes, principle of increase of entropy and its applications, Entropy generation, Entropy and Disorder, Reversible adiabatic process- isentropic process, Third law of thermodynamics.

**Module 4:** Pure Substances, Phase Transformations, Triple point, properties during change of phase, T-v, p-v and p-T diagram of pure substance, p-v-T surface, Saturation pressure and Temperature, T-h and T-s diagrams, h-s diagrams or Mollier Charts, Dryness Fraction, steam tables. Property calculations using steam tables. The ideal Gas Equation, Characteristic and Universal Gas constants, Limitations of ideal Gas Model: Equation of state of real substances, Compressibility factor, Law of corresponding state, Compressibility charts.

**Module 5:** Mixtures of ideal Gases – Mole Fraction, Mass fraction, Gravimetric and volumetric Analysis, Dalton's Law of partial pressure, Amagat's Laws of additive volumes, Gibbs-Dalton's law Equivalent Gas constant and Molecular Weight, Properties of gas mixtures: Internal Energy, Enthalpy, specific heats and Entropy. General Thermodynamic Relations – Combined First and Second law equations – Helmholtz and Gibb's functions - Maxwell's Relations, Tds Equations. The Clapeyron Equation, equations for internal energy, enthalpy and entropy, specific heats, Throttling process, Joule Thomson Coefficient, inversion curve.

## Text Books

1. P. K. Nag, Engineering Thermodynamics, McGraw Hill, 2013
2. E. Rathakrishnan Fundamentals of Engineering Thermodynamics, PHI, 2005
3. Y. A. Cengel and M. A. Boles, Thermodynamics an Engineering Approach, McGraw Hill, 2011

**Reference Books:**

1. Moran J., Shapiro N. M., Fundamentals of Engineering Thermodynamics, Wiley, 2006
2. R. E. Sonntag and C. Borgnakke, Fundamentals of Thermodynamics, Wiley, 2009
3. Holman J. P. Thermodynamics, McGraw Hill, 2004
4. M. Achuthan, Engineering Thermodynamics, PHI, 2004

**COURSE PLAN**

<b>Module</b>	<b>Topics</b>	<b>Hours Allotted</b>
1	Role of Thermodynamics and it's applications in Engineering and Science – Basic Concepts Macroscopic and Microscopic viewpoints, Concept of Continuum, Thermodynamic System and Control Volume, Surrounding, Boundaries, Types of Systems, Universe	2L
	Thermodynamic properties, Process, Cycle, Thermodynamic Equilibrium, Quasi – static Process, State, Point and Path function.	2L
	Zerth Law of Thermodynamics, Measurement of Temperature, reference Points, Temperature Scales.	2L + 1T
2	Energy - Work - Pdv work and other types of work transfer, free expansion work, heat and heat capacity.	2L + 1T
	Joule's Experiment- First law of Thermodynamics - First law applied to Non flow Process- Enthalpy- specific heats- PMM1	2L + 1T
	First law applied to Flow Process, Mass and Energy balance in simple steady flow process. Applications of SFEE, Limitations of first law	2L + 1T
3	Second Law of Thermodynamics, Thermal Reservoir, Heat Engine, Heat pump – Kelvin-Planck and Clausius Statements, Equivalence of two statements	3L
	Reversibility, Irreversible Process, Causes of Irreversibility, PMM2, Carnot's theorem and its corollaries, Absolute Thermodynamic Temperature scale.	2L + 1T
	Clausius Inequality, Entropy- Entropy changes in various thermodynamic processes, principle of increase of entropy and its applications, Entropy generation, Entropy and Disorder, Reversible adiabatic process- isentropic process, Third law of thermodynamics	2L + 2T
4	Pure Substances, Phase Transformations, Triple point, properties during change of phase, T-v, p-v and p-T diagram of pure substance, p-v-T surface,	3L
	Saturation pressure and Temperature, T-h and T-s diagrams, h-s diagrams or Mollier Charts, Dryness Fraction, steam tables. Property calculations using steam tables	2L + 1T

	The ideal Gas Equation, Characteristic and Universal Gas constants, Limitations of ideal Gas Model: Equation of state of real substances, Compressibility factor, Law of corresponding state, Compressibility charts.	2L +1T
5	Mixtures of ideal Gases – Mole Fraction, Mass fraction, Gravimetric and volumetric Analysis, Dalton's Law of partial pressure, Amagat's Laws of additive volumes, Gibbs-Dalton's law.	2L
	Equivalent Gas constant and Molecular Weight, Properties of gas mixtures: Internal Energy, Enthalpy, specific heats and Entropy	2L +1T
	General Thermodynamic Relations – Combined First and Second law equations – Helmholtz and Gibb's functions - Maxwell's Relations	2L
	Tds Equations. The Clapeyron Equation, equations for internal energy, enthalpy and entropy, specific heats, Throttling process, Joule Thomson Coefficient, inversion curve.	2L + 1T

## MODEL QUESTION PAPER

THIRD SEMESTER B.TECH DEGREE EXAMINATION

Course Code : MET284

Course Name : THERMODYNAMICS

( Permitted to use Steam Tables and Mollier Chart )

Max. Marks : 100

Duration : 3 Hours

### Part – A

Answer all questions.

1. Define thermodynamics. List a few of its applications
2. Differentiate between intensive and extensive properties.
3. Differentiate between heat and work.
4. Explain system approach and control volume approach as applied in the analysis of a flow process.
5. An inventor claims to have developed an engine that delivers 26 kJ of work using 82 kJ of heat while operating between temperatures 120°C and 30°C. Is his claim valid ? Give the reason for your answer.
6. Show that two reversible adiabatics cannot intersect
7. Define (i) critical point and (ii) triple point, with respect to water
8. Why do real gases deviate from ideal gas behaviour? When do they approach ideal behaviour?
9. Define Helmholtz function and Gibbs function and state their significance
10. State Dalton's law and Amagat's laws for ideal gas mixtures.

( 3 x 10 = 30 marks )

### Part – B

Answer any two full questions from each module.

#### Module - 1

- 11.a] Explain macroscopic and microscopic approach to thermodynamics . ( 7 marks )
- b] With the aid of a suitable diagram, explain the working of constant volume gas thermometer. ( 7 marks )

OR

- 12.a] What is meant by thermodynamic equilibrium ? What are the essential conditions for a system to be in thermodynamic equilibrium ? ( 7 marks )

b] Express the temperature of  $91^{\circ}\text{C}$  in (i) Fahrenheit (ii) Kelvin (iii) Rankine. ( 7 marks )

### Module – 2

13.a] A mass of 2.4 kg of air at 150 kPa and  $12^{\circ}\text{C}$  is contained in a gas – tight, frictionless piston – cylinder device. The air is now compressed to a final pressure of 600 kPa . During this process, heat is transferred from the air such that the temperature inside the cylinder remains constant. Calculate the work input during this process. ( 7 marks )

a] Air enters a 28 cm diameter pipe steadily at 200 kPa and  $20^{\circ}\text{C}$  with a velocity of 5m/s. Air is heated as it flows, and leaves the pipe at 180 kPa and  $40^{\circ}\text{C}$ . Determine (i) the volume flow rate of air at the inlet (ii) the mass flow rate of air and (iii) the velocity and volume flow rate at the exit. ( 7 marks )

OR

14.a] A turbine operates under steady flow conditions, receiving steam at the following conditions : pressure 1.2 MPa, temperature  $188^{\circ}\text{C}$ , enthalpy 2785 kJ/kg, velocity 33.3 m/s and elevation 3m. The steam leaves the turbine at the following conditions : pressure 20 kPa, enthalpy 25kJ/kg, velocity 100 m/s, and elevation 0 m. Heat is lost to the surroundings at the rate of 0.29 kJ/s. If the rate of steam flow through the turbine is 0.42 kg/s, what is the power output of the turbine in kW ? ( 7 marks )

b] Derive the steady flow energy equation, stating all assumptions. ( 7 marks )

### Module – 3

15.a] State the Kelvin-Planck and Clausius statements of the second law of thermodynamics and prove their equivalence. ( 7 marks )

b] A heat engine operating between two reservoirs at 1000 K and 300 K is used to drive a heat pump which extracts heat from the reservoir at 300 K at a rate twice that at which the engine rejects heat to it. If the efficiency of the engine is 40 % of the maximum possible and the COP of the heat pump is 50 % of the maximum possible, what is the temperature of the reservoir to which the heat pump rejects heat ? What is the rate of heat rejection from the heat pump, if the rate of heat supply to the engine is 50kW ? ( 7 marks )

OR

16.a] A house is to be maintained at  $21^{\circ}\text{C}$  during winter and at  $26^{\circ}\text{C}$  during summer. Heat leakage through the walls, windows and roof is about 3000 kJ/hr per degree temperature difference between the interior of the house and the environment. A reversible heat pump is proposed for realising the desired heating and cooling. What is the minimum power required to run the

heat pump in the reverse, if the outside temperature during summer is  $36^{\circ}\text{C}$ ? Also find the lowest environment temperature during winter for which the inside of the house can be maintained at  $21^{\circ}\text{C}$  consuming the same power. ( 8 marks )

b] Give the Nernst statement of the third law and explain its significance. ( 6 marks )

#### Module – 4

17.a] Show the constant pressure transformation of unit mass of ice at atmospheric pressure and  $-20^{\circ}\text{C}$  to superheated steam at  $220^{\circ}\text{C}$  on P-v, T-v and P-T coordinate systems and explain their salient features. ( 8 marks )

b] Nitrogen enclosed in a piston cylinder arrangement is at a pressure of 2 bar and temperature  $75^{\circ}\text{C}$ . Calculate the specific volume of Nitrogen using ideal gas equation. What would be the specific volume of this Nitrogen, if its compressibility factor at the prevailing condition is 0.9. ( 6 marks )

OR

18.a] Steam at 25 bar and  $300^{\circ}\text{C}$  expands isentropically to 5 bar. Calculate the change in enthalpy, volume and temperature of unit mass of steam during this process using steam tables and Mollier chart and compare the values ( 8 marks )

b] Explain law of corresponding states and its significance to the generalized compressibility chart. ( 6 marks )

#### Module – 5

19.a] Derive the expressions for the equivalent molecular weight and characteristic gas constant for a mixture of ideal gases. ( 6 marks )

b] 0.5 kg of Helium and 0.5 kg of Nitrogen are mixed at  $20^{\circ}\text{C}$  and at a total pressure of 100 kPa. Find (i) volume of the mixture (ii) partial volumes of the components (iii) partial pressures of the components (iv) the specific heats of the mixture and (v) the gas constant of the mixture. Take ratio of specific heats for Helium and Nitrogen to be 1.667 and 1.4 respectively. ( 8 marks )



OR

20.a] 2 kg of carbon dioxide at 38°C and 1.4 bar is mixed with 5 kg of nitrogen at 150°C and 1.03 bar to form a mixture at a final pressure of 70 kPa. The process occurs adiabatically in a steady flow apparatus. Calculate the final temperature of the mixture and the change in entropy during the mixing process. Take specific heat at constant pressure for CO<sub>2</sub> and N<sub>2</sub> as 0.85 kJ/kgK and 1.04 kJ/kg respectively. ( 7 marks )

b] Derive the Maxwell relations. Explain their significance? ( 7 marks )



## ASSESSMENT PATTERN

Bloom's taxonomy	Continuous Assessment Tests		End Semester Examination (Marks)
	Test I (Marks)	Test II (Marks)	
Remember	25	25	25
Understand	15	15	15
Apply	30	25	30
Analyze	10	10	10
Evaluate	10	15	10
Create	10	10	10

### Mark distribution

Total Marks	CIE marks	ESE marks	ESE duration
150	50	100	3 Hours

### Continuous Internal Evaluation (CIE) Pattern:

Attendance	10 marks
Regular class work/tutorials/assignments	15 marks
Continuous Assessment Test (2 numbers)	25 marks

**End semester pattern:-** There will be two parts; Part A and Part B. Part A contain 10 questions with 2 questions from each module, having 3 marks for each question. Students should answer all questions. Part B contains 2 questions from each module of which student should answer any one. Each question can have maximum 2 subdivisions and carry 14 marks.

### Course Level Assessment Questions

**Course Outcome 1 (CO1):** - Illustrate the basic principles of foundry practices and special casting processes, their advantages, limitations and applications.

1. Explain Why casting is an important manufacturing processes
2. Name the important factors in selecting sand for molds.
3. Why does die casting produce the smallest cast parts?
4. What is the difference between sand-mold and shell mold casting?

**Course Outcome 2 (CO2):** Categorize welding processes according to welding principle and material.

1. Describe the functions and characteristics of electrodes. What functions do coatings have? How are electrodes classified?
2. Describe the role of filler metals in welding.
3. Explain the significance of the stiffness of the components being welded on both weld quality and part shape.

**Course Outcome 3 (CO3):** Understand the advantages of LBM and EBM over fusion welding process.

1. What is the power of LBM and EBM used for welding?
2. Why LBM and EBM are better quality than fusion welding?
3. What is the HAZ of LBM as compared to fusion welding process.

**Course Outcome 4 (CO4):** An ability to understand the principles of the basic microelectronic processing technology.

1. Why is silicon the semiconductor most used in IC technology?
2. Define selectivity and isotropy and their importance in relation to etching.
3. Explain the differences between wet and dry oxidation.
4. How is epitaxy different from other techniques used for deposition? Explain.

**Course Outcome 5 (CO5):** Learn about key aspects of the microelectronics industry, from device design, to processing, to photolithography, to manufacturing and packaging. Students will come out knowing the core processes of ion implantation, diffusion, oxidation, deposition, etching, including the fundamental physical mechanisms, and the necessary understanding for using these processes in a manufacturing environment.

1. Describe bulk and surface micromachining.
2. Lithography produces projected shapes, so true three dimensional shapes are more difficult to produce. What lithography processes are best able to produce three-dimensional shapes, such as lenses? Explain.
3. Explain how you would produce a spur gear if its thickness was one-tenth of its diameter and its diameter was (a) 10  $\mu\text{m}$ , (b) 100  $\mu\text{m}$ , (c) 1 mm, (d) 10 mm, and (e) 100 mm.

## SYLLABUS

### Module I

Metal casting:-sand casting:- shell molding, evaporative pattern casting, investment casting, permanent mold casting, vacuum casting, slush casting, pressure casting, die casting, centrifugal casting, squeeze casting, semi solid metal forming, casting for single crystal, casting defects.

### Module II

Powder metallurgy:-powder production methods; powder characteristics; blending, mixing; compaction of metal powders; sintering fundamentals and mechanisms; infiltration and impregnation - Welding: arc welding: non consumable electrodes; heat affected zone; quality; case study and weld ability of metals.

### Module III

Consumable electrodes; electron and laser beam welding; heat affected zone; power density; weld

quality; case study; applications - Brazing:- filler metals, fluxes, joint strength; brazing methods, applications -Soldering:- solders and fluxes - soldering methods - solder ability, case study, typical joint designs, applications.

#### **Module IV**

Metal forging: quality, defects -Metal extrusion: process, defects, applications - Metal drawing process, drawing practice, defects, applications - Fabrication of microelectronic devices - crystal growing and wafer preparation - Film deposition - oxidation - Photo lithography

#### **Module V**

Different lithography methods - Etching, wet etching, dry etching- diffusion and Ion implantation- metallization and testing - wire bonding and packing - yield and reliability - fabrication of micro electro mechanical devices.

#### **Text Books**

1. Serope Kalpakjian, Steven R. Schmid - Manufacturing Engineering and Technology, seventh edition, Pearson.

#### **Reference**

1. <https://nptel.ac.in/courses/103106075/>
2. Principles of Metal Casting – Hine and Rosenthal
3. Materials and Processes in Manufacturing - Paul Degarma E and Ronald A. Kosher
4. Manufacturing Technology Foundry, Forming and Welding – P. N. Rao

### **MODEL QUESTION PAPER**

**MANUFACTURING PROCESS - MET 286 Max. Marks :**

**100**

**Duration : 3 Hours**

#### **Part – A**

**Answer all questions.**

**Answer all questions, each question carries 3 marks**

1. What are composite molds? Why are they used?
2. What are the advantages of pressure casting over other processes?
3. Describe what occurs to metal powders during sintering.
4. Explain the basic principles of arc-welding processes.
5. Are fluxes necessary in brazing? If so, why?
6. Soldering is generally applied to thinner components. Explain Why.
7. Why is control of the volume of the blank important in closed-die forging?
8. Define selectivity and isotropy and their importance in relation to etching.
9. Describe the difference between isotropic etching and anisotropic etching.
10. What is the difference between chemically reactive ion etching and dry-plasma etching?

#### **PART -B**

**Answer one full question from each module.**

#### **MODULE -1**

11. Explain why squeeze casting produces parts with better mechanical properties, dimensional accuracy, and surface finish than do expendable-mold processes (14 marks).

**OR**

12. Explain different types of casting defects in detail (14 marks).

**MODULE -2**

13. a.Explain the difference between impregnation and infiltration. Give some applications of each (7 marks).  
b.Describe the relative advantages and limitations of cold and hot isostatic pressing (7 marks).

**OR**

14. Explain the factors that contribute to the differences in properties across a welded joint (14 marks).

**MODULE -3**

15. a.What are the principles of (a) wave soldering and (b) reflow soldering? (7 marks).  
b.It is common practice to tin-plate electrical terminals to facilitate soldering. Why is it tin that is used? (7 marks).

**OR**

16. Examine various household products and describe how their components are joined and assembled. Explain why those particular processes were used and not others (14 marks).

**MODULE -4**

17. a.Describe the factors involved in precision forging (7 marks).  
b.Explain why cold extrusion is an important manufacturing process (7 marks).

**OR**

18. a.A common problem in ion implantation is channeling, in which the high-velocity ions travel deep into the material via channels along the crystallographic planes before finally being stopped. How could this effect be avoided? Explain (7 marks).  
b.Describe your understanding of the important features of clean rooms and how they are maintained (7 marks).

**MODULE -5**

19. a.List the advantages and disadvantages of surface micromachining compared with bulk micromachining (7 marks).  
b.What is the difference between chemically reactive ion etching and dry-plasma etching? (7 marks).

**OR**

20. a. What is the main limitation to successful application of MEMS? (7 marks).  
b. What is the purpose of a spacer layer in surface micromachining? (7 marks).

**Course content and lecture schedules.**

<b>Module</b>	<b>TOPIC</b>	<b>No. of hours</b>	<b>Course outcomes</b>
1.1	Metal casting:-sand casting:- sand, types of sand mold, pattern, cores, casting operations.	2	CO1
1.2	Shell molding, plaster and ceramic mold casting; evaporative pattern casting, investment casting,	3	CO1 CO5
1.3	Permanent mold casting, vacuum casting, slush casting, pressure casting, die casting,	2	

1.4	Centrifugal casting, squeeze casting, semi solid metal forming - applications of each process.	2	CO1
1.5	Casting for single crystal, applications of each process, casting defects.	1	
2.1	Powder metallurgy:-powder production methods, atomization, reduction, electrolytic deposition, carbonyls, comminution.	2	CO2
2.2	Powder characteristics:- particle size, shape and distribution	1	CO2 CO5
2.3	Blending, mixing and compaction of metal powders, isostatic pressing	2	CO2
2.4	Sintering: fundamentals and mechanisms - infiltration and impregnation.	1	
2.5	Welding: arc welding non consumable electrodes, heat transfer in arc welding, gas tungsten arc, plasma arc and atomic hydrogen welding; heat affected zone, weld ability, weld quality, applications of each processes.	3	CO4 CO5
3.1	Consumable electrodes:-shielded metal, submerged, gas metal arc welding, heat affected zone, weld ability, weld quality, applications of each processes.	3	CO4
3.3	Electron and laser beam welding, heat affected area, power density, weld quality, heat affected zone, case study, applications of each processes.	1	
3.4	Brazing:- filler metals, fluxes, joint strength; brazing methods, torch, furnace, induction, resistance, dip brazing, applications of each processes.	2	CO4
3.5	Soldering:-types of solders and fluxes - different soldering methods - solder ability, case study, typical joint designs, applications of each processes.	2	CO4
4.1	Metal forging:-open die, impression die, closed die, precision die, quality, defects.	3	CO4
4.2	Metal extrusion:-process, hot, cold, impact and hydrostatic extrusion; defects, applications - Metal drawing process- drawing practice- defects, applications of each processes.	3	
4.3	Fabrication of microelectronic devices:-clean rooms-semiconductors and silicon- crystal growing and wafer preparation	2	CO4
4.4	Film deposition - oxidation - Photo lithography	1	
5.1	electron beam lithography, X-ray, Ion beam, photo resistant lithography, scattering with angular limitations projection electron beam lithography.	1	CO4
5.2	Etching:- wet etching:- isotropic etchants, anisotropic etching - dry etching:-sputter, reactive plasma, physical chemical and cryogenic dry etching.	2	CO4
5.3	Diffusion and Ion implantation- metallization and testing- Wire bonding and packing-yield and reliability - printed circuit boards	3	CO4 CO5
5.4	Fabrication of micro electro-mechanical devices:-micromachining of MEMS devices: bulk and surface micro machining, single crystal silicon reactive etching and metallization, silicon micromachining by single step plasma etching, etching combined with diffusion bonding with suitable example and applications.	3	CO4

**SEMESTER -4**  
**HONOURS**



COURSE CODE	COURSE NAME	CATEGORY	L	T	P	CREDITS
22MEHR411.1	CONTINUUM MECHANICS	HR	3	1	0	4

**Preamble:**

At the end of the course the students will have a comprehensive, systematic and integrated knowledge of the principles of continuum mechanics. They be conversant with physical laws and analytical tools such as tensor calculus required to formulate and solve continuum problems. Also they have an in-depth understanding of the common principles which underlie the disciplines of solid mechanics and fluid mechanics – hitherto considered mostly separate. The course equip the students to pursue further specialized areas of study such as aeroelasticity, nonlinear mechanics, biomechanics etc. which are essentially based on continuum mechanics.

**Prerequisite:**

MECHANICS OF SOLIDS

**Course Outcomes:**

After the completion of the course the student will be able to

<b>CO 1</b>	<b>Make use of the concepts of tensor formalism for practical applications</b>
<b>CO 2</b>	<b>Apply deformation and strain concepts for practical situations</b>
<b>CO 3</b>	<b>Identify stresses acting on components subjected to complex loads</b>
<b>CO 4</b>	<b>Make use of fundamental laws for problem formulations and mathematical modeling</b>
<b>CO 5</b>	<b>Develop constitutive relations and solve 2 D elasticity problems</b>

**Mapping of course outcomes with program outcomes**

	PO 1	PO 2	PO 3	PO 4	PO 5	PO 6	PO 7	PO 8	PO 9	PO10	PO 11	PO 12
<b>CO 1</b>	3				2				2			3
<b>CO 2</b>	3	3	3		2	1			2			3
<b>CO 3</b>	3	3	3		2	1			2			3
<b>CO 4</b>	3								2			3
<b>CO 5</b>	3	3	3		2	1			2			3

## Assessment Pattern

Bloom's Category	Continuous Assessment		End Semester Examination
	Tests		
	1	2	
Remember	10	10	10
Understand	20	20	20
Apply	20	20	70
Analyse			
Evaluate			
Create			

## Mark distribution

Total Marks	CIE	ESE	ESE Duration
150	50	100	3 hours

### Continuous Internal Evaluation Pattern:

Attendance	: 10 marks
Continuous Assessment Test (2 numbers)	: 25 marks
Assignment/Quiz/Course project	: 15 marks

### End Semester Examination Pattern:

There will be two parts; Part A and Part B. Part A contain 10 questions with 2 questions from each module, having 3 marks for each question. Students should answer all questions. Part B contains 2 questions from each module of which student should answer any one. Each question can have maximum 2 sub-divisions and carry 14 marks.

## COURSE LEVEL ASSESSMENT QUESTIONS

### Course Outcome 1

1. With the help of mathematical derivations obtain the relation between circulation of a vector field per unit area around a point in a plane and curl of the vector.
2. Prove the vector identity  $u \times (v \times w) = (u \cdot w)v - (u \cdot v)w$
3. Show that a)  $\delta_{3p} v_p = v_3$  b)  $\delta_{3i} A_{ji} = A_{j3}$

## Course Outcome 2

1. Discuss the physical interpretations of components of Linearized strain tensor.
2. Given the displacement components  $u_1 = kx_2^2, u_2 = 0, u_3 = 0, k = 10^{-4}$ , obtain infinitesimal strain tensor E
3. Given  $x_1 = X_1 + 2X_2, x_2 = X_2, x_3 = X_3$ , obtain the right Cauchy Green deformation tensor, right stretch tensor and rotation tensor.

## Course Outcome 3

1. Given a continuum, where the stress state is known at one point and is represented by the Cauchy stress tensor components  $[\sigma_{ij}] = \begin{bmatrix} 1 & 1 & 0 \\ 1 & 1 & 0 \\ 0 & 0 & 2 \end{bmatrix}$  Pa, find the principal stresses and principal directions.
2. The stress state at one point is represented by the Cauchy stress components  $[\sigma_{ij}] = \begin{bmatrix} \sigma & a\sigma & b \\ a\sigma & \sigma & c\sigma \\ b\sigma & c\sigma & \sigma \end{bmatrix}$ , where  $a, b, c$  constants are and  $\sigma$  is the value of the stress. Determine the constants such that the traction vector on the octahedral plane is zero.
3. Find the maximum principal stress, maximum shear stress and their orientations for the state of stress given  $[\sigma_{ij}] = \begin{bmatrix} 6 & 9 & 0 \\ 9 & -6 & 0 \\ 0 & 0 & 3 \end{bmatrix}$  MP

## Course Outcome 4

1. Explain Reynold's Transport Theorem
2. Prove the symmetry of stress using principle of conservation of angular momentum.
3. Obtain the Eulerian form of continuity equation

## Course Outcome 5

1. From linear elastic constitutive relation for isotropic materials, deduce the strain stress relation  $\epsilon_{ij} = \frac{1+\nu}{E} \sigma_{ij} - \frac{\nu}{E} \sigma_{kk} \delta_{ij}$
2. Formulate the stress compatibility equation for plain strain problems in the absence of body force.
3. Derive the stress compatibility equation for a plain stress problem with body force. State the condition under which it becomes the biharmonic equation.

## MODEL QUESTION PAPER

### IV SEMESTER B.TECH DEGREE EXAMINATION

Course Code : MET292

Course Name : CONTINUUM MECHANICS

#### PART A

*Each question carries three marks*

1. Differentiate between vector space and inner product space.
2. Prove  $\text{div}(\mathbf{A} \times \mathbf{B}) = \text{curl} \mathbf{A} \cdot \mathbf{B} - \text{curl} \mathbf{B} \cdot \mathbf{A}$ , using indicial notation.
3. Differentiate between Lagrangian and Eulerian description of fluid motion.
4. The Lagrangian coordinate of a material particle is  $(x(t), y(t), z(t))$ . Obtain the mathematical expression for the component of acceleration along the direction of motion of the material particle.
5. Derive an equation for octahedral shear stress in terms of the stress invariants.
6. The Cauchy stress tensor at a point P is given  $\sigma_{ij} = \begin{bmatrix} 5 & 6 & 7 \\ 6 & 8 & 9 \\ 7 & 9 & 2 \end{bmatrix}$  GPa. Obtain the deviatoric and volumetric parts of the tensor.
7. Deduce the equilibrium equations from linear momentum principle.
8. Express the local and global form of Reynold's Transport Theorem.
9. Write down the stress strain relations of a linear elastic isotropic material.
10. Write down the radial and tangential components of stress in terms of Airy's stress function.

#### PART B

Answer one full question from each module.

#### MODULE 1

- 11 a) Evaluate using indicial notation (8)
- i.  $\mathbf{u} \times (\mathbf{v} \times \mathbf{w})$
  - ii.  $(\mathbf{uv}) : (\mathbf{ws})$
- b) Expand using summation convention (6)
- iii.  $\rho \dot{v}_i = \rho b_i + \sigma_{ij,j}$
  - iv.  $e'_i = Q_{mi} e_m$

OR

12 a) Prove that  $[A \ B \ C][D \ E \ F] = \begin{bmatrix} A.D & A.E & A.F \\ B.D & B.E & B.F \\ C.D & C.E & C.F \end{bmatrix}$ , from there show that

$$e_{ijk}e_{rst} = \begin{bmatrix} \delta_{ir} & \delta_{is} & \delta_{it} \\ \delta_{jr} & \delta_{js} & \delta_{jt} \\ \delta_{kr} & \delta_{ks} & \delta_{kt} \end{bmatrix} \quad (9)$$

b) Establish the identity  $e_{ijk}e_{mn} = \delta_{im}\delta_{jn} - \delta_{in}\delta_{jm}$  (5)

## MODULE 2

13 a) Given the motion of a body  $x_i = X_i + 0.2tX_2\delta_{1i}$ , for a temperature field given by  $\theta = 2x_1 + (x^2)^2$ , find the material description of temperature and the rate of change of temperature of a particle at time  $t=0$ , which was at the place  $(0,1,0)$ . (8)

b) Derive compatibility equation (6)

OR

14 a) Given that  $[F] = \begin{bmatrix} \sqrt{3} & 1 & 0 \\ 0 & 2 & 0 \\ 0 & 0 & 1 \end{bmatrix}$ , determine the left and right stretch tensors. (14)

b) Explain infinitesimal deformation theory.

c) Obtain an expression for Linearized strain.

## MODULE 3

15 a) The stress matrix in MPa when referred to axes  $Px_1x_2x_3$  is (14)

$$[\sigma_{ij}] = \begin{bmatrix} 3 & 10 & 0 \\ -10 & 0 & 30 \\ 0 & 30 & -27 \end{bmatrix}$$

Determine

- i. the principal stresses
- ii. principal planes
- iii. maximum shear stress
- iv. Octahedral normal and shear stress

OR

- 16 a) The principal stresses of stress at a point are  $\sigma_1, \sigma_2$  and  $\sigma_3$  with  $\sigma_1 > \sigma_2 > \sigma_3$ . Now derive equations of the direction cosines of a plane passing through this point, which is subjected to normal and shear stress  $\sigma_n$  and  $\tau_n$  respectively. (6)
- b) For the stress state given

$$[\sigma_{ij}] = \begin{bmatrix} 12 & 9 & 0 \\ 9 & -12 & 0 \\ 0 & 0 & 6 \end{bmatrix} MPa$$

where the Cartesian coordinate variables  $X_i$  are in meters and the unit of stress are MPa. Determine the principal stresses and principal directions of stress at the point  $X = e_1 + 2e_2 + 3e_3$ . (8)

#### MODULE 4

- 17 a) Derive the differential form of conservation of energy. (4)
- b) What is localization theorem? Write down its relevance in the derivation of differential equations. (6)
- c) Derive the Cauchy's equation of motion using the conservation of linear momentum principle (4)

OR

- 18 a) Prove the symmetry of stress  $\sigma_{ij} = \sigma_{ji}$  using principle of conservation of angular momentum. (8)
- b) Obtain the Eulerian form of continuity equation. (8)

#### MODULE 5

- 19 a) Show that for an isotropic elastic medium (6)
- a.  $\lambda = \frac{E\nu}{(1+\nu)(1-2\nu)}$       b)  $\mu = \frac{E}{2(1+\nu)}$
- b. Determine the radial stress and tangential stress developed in a thick cylinder of internal radius ' $a$ ' and external radius ' $b$ ' subjected internal pressure  $P_i$  and external pressure  $P_o$  using stress function method. (8)

OR

- 20 Consider a special stress function having the form  $\phi = B_2 x_1 x_2 + D_4 x_1 x_3$ . Show that this stress function may be adapted to solve for the stresses in an end-loaded cantilever beam as shown in the sketch. Assume the body forces are zero for this problem. (14)

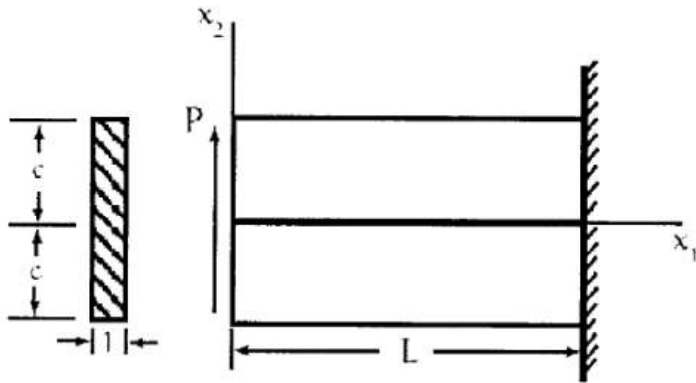

# SYLLABUS

## Module 1

Mathematical preliminaries - Index notation, Einstein's summation convention- Kronecker delta and Levi-Civita symbols, Cartesian basis- Concept of tensor- Tensor as a linear transformation - Vector as a first order tensor- Coordinate transformation of vectors and tensors.

Principal values, trace and invariants-Gradient, divergence and curl of vector and tensor fields- Vector identities-Gauss' divergence and Stokes' theorems.

## Module 2

Concept of continua- Reference and current configuration- Deformation gradient tensor- Lagrangian and Eulerian description of motion.

Polar decomposition theorem- Right and left Cauchy Green tensors- Infinitesimal deformation theory- Linearized strain- Principal strains- Saint Venant's compatibility equations

## Module 3

Traction- Cauchy stress tensor- Stress component along orthonormal basis vector- Components of Cauchy stress tensor on any plane.

Principal planes- Principal stress components- Normal and shear stresses- Stress transformation- Equilibrium equations

## Module 4

Balance Laws - Reynold's transportation theorem- Localization theorem- Lagrangian and Eulerian forms of equation for mass balance.

Balance of linear momentum equation- Balance of angular momentum- Symmetry of stress tensor- Balance of energy

## Module 5

Constitutive relations - Generalized Hooke's law for isotropic materials in indicial and matrix forms- Relation connecting Lamé's constants with Young's modulus, Poisson's ratio and Bulk modulus.

2D formulation of field equations; Airy's stress function- Biharmonic equation-Uni axial tension and pure bending of a beam; End loaded cantilever- Polar coordinates- Axisymmetric formulation- Lamé's thick cylinder problem- Quarter circle cantilevered beam with radial load.



### Text Books

1. G. Thomas Mase, George E. Mase.. Ronald E. Smelser. Continuum mechanics for engineers 3rd ed CRC Press
2. . Lawrence E. Malvern. Introduction to the Mechanics of a Continuous Medium – Prentice Hall

### Reference Books

1. J.H. Heinbockel, Introduction to Tensor Calculus and Continuum Mechanics – Open Source
2. W. Michael Lai, David Ribin, Erhard Kaempl, Introduction to Continuum Mechanics 4th Ed., Butterworth- Heinemann
3. J. N. Reddy, An Introduction to Continuum Mechanics with applications - Cambridge University Press
4. Y. C. Fung, A First Course in Continuum Mechanics for Physical and Biological Engineers and scientists - Prentice Hall
5. Han-Chin W, Continuum mechanics and plasticity - CRC Press
6. Sudhakar Nair, Introduction to Continuum Mechanics – Cambridge University press
7. Morton E. Gurtin, An introduction to continuum mechanics, Academic Press
8. S.P. Timoshenko, J.N. Goodier, Theory of Elasticity, 3rd Edition, McGraw Hill Publishing

## COURSE CONTENTS AND LECTURE SCHEDULE

Sl. No.	Topic	Number of lecture hours
1	Index notation, Einstein's summation convention- Kronecker delta and Levi-Civita symbols	2
2	Cartesian basis- Concept of tensor- Tensor as a linear transformation - Vector as a first order tensor	1
3	Coordinate transformation of vectors and tensors.	2
4	Principal values, trace and invariants	2
5	Gradient, divergence and curl of vector and tensor fields	2
6	Vector identities-Gauss' divergence and Stokes' theorems.	1
7	Concept of continua- Reference and current configuration, Lagrangian and Eulerian description of motion	2
8	Deformation gradient tensor, Right and left Cauchy Green tensors	2

9	Infinitesimal deformation theory- Linearized strain	2
10	Principal strains	1
11	Polar decomposition theorem	1
12	Saint Venant's compatibility equations	1
13	Traction- Cauchy stress tensor- Stress component along orthonormal basis vector	2
14	Components of Cauchy stress tensor on any plane., Normal and shear stresses	2
15	Principal planes- Principal stress components	2
16	Stress transformation	2
17	Reynold's transportation theorem- Localization theorem, Introduction on Balance Laws	1
18	Lagrangian and Eulerian forms of equation for mass balance.	1
19	Balance of linear momentum, equilibrium equations	1
20	Balance of angular momentum, Symmetry of stress tensor	1
21	Balance of energy	1
22	Constitutive relations - Generalized Hooke's law for isotropic materials in indicial and matrix forms	1
23	Relation connecting Lamé's constants with Young's modulus, Poisson's ratio and Bulk modulus.	1
24	2D formulation of field equations; Airy's stress function; Biharmonic equation	4
25	Uni axial tension and pure bending of a beam; End loaded cantilever	1
26	Polar coordinates; Axisymmetric formulation	2
27	Lamé's thick cylinder problem	2
28	Quarter circle cantilevered beam with radial load.	2

COURSE CODE	COURSE NAME	CATEGORY	L	T	P	CREDITS
22MEHR411.2	ADVANCED MECHANICS OF FLUIDS	HR	3	1	0	4

**Preamble:**

This course is a survey of principal concepts and methods of fluid dynamics. Topics include conservation equations, exact solutions of Navier-Stokes Equations, potential flow solutions, Boundary layers; introduction to turbulence and turbulence modelling

**Prerequisite:**

MET 203- Mechanics of Fluids

**Course Outcomes:** After the completion of the course the student will be able to

<b>CO 1</b>	Apply conservation equations of fluid mechanics
<b>CO 2</b>	Use potential flow theory in fluid problems
<b>CO 3</b>	Utilize approximate solutions of the Navier-Stokes equations
<b>CO 4</b>	Compute effect on boundary layers.
<b>CO 5</b>	Explain turbulence and turbulence modelling

**Mapping of course outcomes with program outcomes**

	PO 1	PO 2	PO 3	PO 4	PO 5	PO 6	PO 7	PO 8	PO 9	PO 10	PO 11	PO 12
<b>CO 1</b>	3											
<b>CO 2</b>	3	2	1									
<b>CO 3</b>	3	2	1	1								
<b>CO 4</b>	3	2	1									
<b>CO 5</b>	3	1										

**Assessment Pattern**

Blooms Category	CA			ESA
	Assignment	Test - 1	Test - 2	
Remember	25	20	20	10
Understand	25	40	40	20
Apply	25	40	40	70
Analyse	25			
Evaluate				
Create				

**Continuous Internal Evaluation Pattern:**

Attendance : 10 marks

Continuous Assessment Test (2 numbers) : 25 marks

Assignment/Quiz/Course project : 15 marks

**Mark distribution & Duration of Examination :**

Total Marks	CA	ESE	ESE Duration
150	50	100	3 Hours

**End semester pattern:**

There will be two parts; Part A and Part B. Part A contain 10 questions with 2 questions from each module, having 3 marks for each question. Students should answer all questions. Part B contains 2 questions from each module of which student should answer any one. Each question can have maximum 2 sub-divisions and carry 14 marks.

## COURSE LEVEL ASSESSMENT QUESTIONS

### Course Outcome 1

1. What is the significance of RTT in the study of transport phenomena.
2. Explain the relationship between the stress tensor and the rate of deformation.
3. Derive the expression for the Navier-Stokes equation and explain the different terms involved.

### Course Outcome 2

1. Derive the expression for stream function and potential function of a doublet using the potential flow theory.
2. Derive the expression for lift for flow past a cylinder with circulation.
3. What is the significance of conformal mapping?

### Course Outcome 3

1. Derive the expression for the pressure gradient for Couette flow.
2. Explain the working of a Viscometer based on the flow through a rotating annulus.
3. What is Stokes' first problem?

### Course Outcome 4

1. Explain the development of boundary layer along a thin flat plate held parallel to a uniform flow. Point out the salient features.
2. Discuss on the effect of pressure gradient on boundary layer separation.
3. Find the thickness of the boundary layer at the trailing edge of a smooth plate of length 5 m and width 1.2 m when the plate is moving at 5 m/s in stationary air. Take the kinematic viscosity of air as 0.11 stokes.

### Course Outcome 5

1. What are the semi-empirical theories associated with turbulent flow?
2. Explain the two equation models used in turbulent flow.
3. Distinguish between DNS and LES.

## Syllabus

**Module 1:** Concept of viscosity, stress tensor, relation between stress and rate of deformation, Stokes hypothesis, Reynolds Transport Theorem, Mass, Momentum and Energy conservation, Derivation of Navier-Stokes equations.

**Module 2:** Potential flow: Uniform flow, source flow, sink flow, free vortex flow and super imposed flow-source and sink pair, doublet, plane source in a uniform flow (flow past a half body), source and sink pair in a uniform flow (flow past a Rankine oval body), doublet in a uniform flow (flow past a circular cylinder). Pressure distribution on the surface of the cylinder. Flow past a cylinder with circulation, Kutta-Juokowsky's law. Complex flow potential, complex flow potentials for source, sink, vortex and doublet. Potential flow between two parallel plates, potential flow in a sector. Introduction to conformal transformation, conformal mapping.

**Module 3:** Exact Solutions of Navier Stokes Equations. Parallel flow through straight channel and Couette flow. Couette flow for negative, zero and positive pressure gradients, flow in a rotating annulus, Viscometer based on rotating annulus. Flow at a wall suddenly set to motion (Stokes first problem)

**Module 4:** Boundary layer equations; Boundary layer on a flat plate, Prandtl boundary layer equations, Blasius solution for flow over a flat plate, Von- Karman momentum integral equations, Pohlhausen approximation solution of boundary layer for non-zero pressure gradient flow, favorable and adverse pressure gradients, flow separation and vortex shedding. Boundary layer control.

**Module 5:** Introduction Statistical approach to turbulent flows, Length and time scales and Kolomogrov's energy cascading theory Reynolds averaged Navier Stokes equations, Turbulence modeling. Concept of eddy viscosity and Prandtl's mixing length hypothesis Zero, one and two equation turbulence models and Reynold's stress models. Concepts of LES and DNS.

### Text Books

- (1) White, F. M. *Viscous Fluid Flow*, McGraw Hill Education; 3 edition, 2017
- (2) Schlichting, H. *Boundary layer theory*. McGraw Hill Education; 7 edition, 2014

## COURSE PLAN

Module	Topics	Hours Allotted
<b>I</b>	Concept of viscosity, stress tensor, relation between stress and rate of deformation, Stokes hypothesis, Reynolds Transport Theorem, Mass, Momentum and Energy conservation, Derivation of Navier-Stokes equations.	6-2-0
<b>II</b>	Potential flow: Uniform flow, source flow, sink flow, free vortex flow and super imposed flow-source and sink pair, doublet, plane source in a uniform flow(flow past a half body), source and sink pair in a uniform flow(flow past a Rankine oval body), doublet in a uniform flow(flow past a circular cylinder). Pressure distribution on the surface of the cylinder. Flow past a cylinder with circulation, Kutta-Juokowsky's law. Complex flow potential, complex flow potentials for source, sink, vortex and doublet. Potential flow between two parallel plates, potential flow in a sector. Introduction to conformal transformation, conformal mapping.	7-2-0
<b>III</b>	Exact Solutions of Navier Stokes Equations. Parallel flow through straight channel and couette flow. Couette flow for negative, zero and positive pressure gradients, flow in a rotating annulus, Viscometer based on rotating annulus. Flow at a wall suddenly set to motion (Stokes first problem)	6-2-0
<b>IV</b>	Boundary layer equations; Boundary layer on a flat plate, Prandtl boundary layer equations, Blasius solution for flow over a flat plate, Von- Karman momentum integral equations, Pohlhausen approximation solution of boundary layer for non-zero pressure gradient flow, favorable and adverse pressure gradients, flow separation and vortex shedding. Boundary layer control.	8-3-0
<b>V</b>	Introduction Statistical approach to turbulent flows, Length and time scales and Kolomogrov's energy cascading theory Reynolds averaged Navier Stokes equations, Turbulence modeling. Concept of eddy viscosity and Prandtl's mixing length hypothesis Zero, one and two equation turbulence models and Reynold's stress models. Concepts of LES and DNS.	7-2-0

## MODEL QUESTION PAPER

### IV SEMESTER B.TECH DEGREE EXAMINATION

MET294 ADVANCED MECHANICS OF FLUIDS Mechanical

Engineering

Maximum: 100 Marks

Duration: 3 hours

### PART A

Answer all questions, each question carries 3 marks

1. What is Stokes hypothesis?
2. What is the importance of RTT in the study of transport phenomena?
3. What are the different elementary flows used in potential flow theory?
4. Draw the stream-lines and potential lines for a doublet in a uniform flow and mark the different regions.
5. With a neat sketch explain the Stokes first problem.
6. Draw the velocity profile in Couette flow for negative, zero and positive pressure gradients.
7. With a neat sketch explain the different regions of boundary layer flow over a flat plate
8. What are the different methods employed in controlling the boundary layer separation?
9. Explain Prandtl's Mixing length theory.
10. What is the importance of Turbulence Modeling in fluid dynamics?

(10×3=30 Marks)



## PART B

Answer one full question from each module

### MODULE-I

11. (a) Derive Reynolds Transport Theorem. (7 Marks)  
(b) Derive the expression for the law of conservation of mass from RTT. (7 Marks)
12. (a) Derive Navier-Stokes equations in Cartesian coordinate system. (10 Marks)  
(b) Write the expanded form of Navier-Stokes equations in Cartesian coordinate system. (4 Marks)

### MODULE-II

13. (a) Explain uniform flow with source and sink. Obtain an expression for stream and velocity potential function and show their approximate distribution. (7 Marks)  
(b) A uniform flow with a velocity of 2m/s is flowing over a source placed at the origin. The stagnation point occurs at  $(-0.398, 0)$ . Determine: (i) Strength of the source, (ii) Maximum width of Rankine half-body and (iii) Other principal dimensions of the Rankine half-body. (7 Marks)
14. (a) A uniform flow with a velocity of 3m/s is flowing over a plane source of strength  $30\text{m}^2/\text{s}$ . The uniform flow and source flow are in the same plane. A point  $P$  is situated in the flow field. The distance of the point  $P$  from the source is 0.5m and it is at an angle of  $30^\circ$  to the uniform flow. Determine: (i) stream function at point  $P$  (ii) resultant velocity of flow at  $P$  and (iii) location of stagnation point from the source. (10 Marks)  
(b) Describe the following terms: i) Complex flow potential ii) Conformal mapping (4 Marks)

### MODULE-III

15. (a) An oil of viscosity 18 poise flows between two horizontal fixed parallel plates which are kept 150mm apart. The maximum velocity of flow is 1.5m/s. Find:  
i. The pressure gradient  
ii. The shear stress at the two horizontal parallel plates  
iii. The discharge per unit width for laminar flow of oil. (7 Marks)
- (b) Explain the significance of Navier-Stokes equation in viscous fluid flow. Derive the expression for flow in a rotating annulus from the Navier-Stokes Equation. (7 Marks)
16. (a) Derive the expression for pressure gradient in the parallel flow through a straight channel. (7 Marks)  
(b) Explain the working of a Viscometer based on the flow through a rotating annulus. (7 Marks)

### MODULE-IV

17. (a) Explain the essential features of Blasius method of solving laminar boundary layer equations for a flat plate. Derive an expression for boundary layer thickness from this solution. (7 Marks)

- (b) For the velocity profile for laminar boundary layer flows given as

$$\frac{u}{U} = 2(y/\delta) - (y/\delta)^2$$

find an expression for boundary layer thickness ( $\delta$ ), shear stress ( $\tau_0$ ) and co-efficient of drag ( $C_D$ ) in terms of Reynold number. (7 Marks)

18. (a) For the velocity profile in laminar boundary layer as,

$$\frac{u}{U} = \frac{3}{2} \left( \frac{y}{\delta} \right) - \frac{1}{2} \left( \frac{y}{\delta} \right)^3$$

find the thickness of the boundary layer and the shear stress 1.5 m from the leading edge of a plate. The plate is 2m long and 1.4m wide and is placed in water which is moving with a velocity of 200mm per second. Find the total drag force on the plate if  $\mu$  for water = .01 poise. (7 Marks)

- (b) Derive Von Karman momentum integral equation for boundary layer flows. (7 Marks)

### MODULE-V

19. (a) Explain and differentiate DNS and LES. (7 Marks)

- (b) What is the difference between zero equation, one equation and two equation models in turbulent flow? (7 Marks)

20. (a) Explain in detail any one of the two equation models. (7 Marks)

- (b) Explain Kolmogorovs energy cascade theory. (7 Marks)



## ASSESSMENT PATTERN

Bloom's taxonomy	Continuous Assessment Tests		End Semester Examination (Marks)
	Test 1 (Marks)	Test 11 (Marks)	
Remember	25	25	25
Understand	15	15	15
Apply	30	25	30
Analyze	10	10	10
Evaluate	10	15	10
Create	10	10	10

### Mark distribution

Total Marks	CIE marks	ESE marks	ESE duration
150	50	100	3 Hours

### Continuous Internal Evaluation (CIE) Pattern:

Attendance	10 marks
Regular class work/tutorials/assignments	15 marks
Continuous Assessment Test (2 numbers)	25 marks

**End semester pattern:-** There will be two parts; Part A and Part B. Part A contain 10 questions with 2 questions from each module, having 3 marks for each question. Students should answer all questions. Part B contains 2 questions from each module of which student should answer any one. Each question can have maximum 2 sub-divisions and carry 14 marks.

### Course Level Assessment Questions

#### Part -A

**Course Outcome 1 (CO1):** Understand the chemical bonds, crystal structures and their relationship with the properties.

1. Why electrons of higher principal quantum number form weaker bonds.
2. Postulate why ionic and covalent bonded material exhibit bad conductors of heat and electricity?
3. What are the roles of surface imperfections on crack initiation.
4. Which mechanism of strengthening is the Hall- Petch equation related to?

**Course Outcome 2 (CO2):** Correlate structure and properties relationship for high temperature applications.

1. Nickel has an atomic weight of 58.71, a number which arises from the relative proportions of isotopes of weights 58, 60, 61, 62 and 64. Why is there little contribution from the isotopes of weight 59 and 63?
2. Comparison of the rates of interdiffusion of the transition group metals (the solutes) with nickel (the solvent) indicates that (i) the interdiffusion rate increases with increasing misfit strain between solvent and solute and (ii) the activation energy for interdiffusion decreases with increasing misfit strain. Why might these observations be contrary to expectation? How might this apparent anomaly be rationalised?

**Course Outcome 3 (CO3):** Understand the attributes and purity level obtainable through triple vacuum induction melting process.

1. What is the need of vacuum for obtaining purifying metals?
2. What are conditions for freckle formation and how can be eliminated?
3. Explain the need of electrode quality in ESR and VAR process?
4. Which are the factors governs the quality of vacuum arc remelting process.

**Course Outcome 4 (CO4):** To have knowledge in improving material strength against high temperature environment and predict life time.

1. Explain why it might not be sensible, even for single-crystal superalloys, to eliminate completely the grain-boundary strengtheners such as carbon and boron from the melt chemistry.
2. The rate of oxide formation in  $\text{Al}_2\text{O}_3$  forming single-crystal superalloys is greatly increased with additions of Ti to the alloy chemistry. Explain why this effect occurs.
3. Non-conductive material will you recommend to use at high temperature explain?
4. Both titanium and steel melt at temperatures in excess of 1500 C. Steel can be used at temperatures as high as 1000C but titanium cannot. Why is this?

**Course Outcome 5 (CO5):** Understand the properties of super alloys and its strengthening processes.

1. The following defects can occur during the casting of single-crystal components:(i) high-angle grain boundaries, (ii) freckles and (iii) spurious grains. What is meant by these terms? Give a brief explanation of the origin of each effect.
2. Suggest a high electrical conductive material which can use at 1100C.
3. Give two reasons why the use of titanium alloys is increasing at the expense of aluminum in both civil and military aircraft.

## SYLLABUS

### MODULE - 1

Atomic structure- chemical bonds-crystallography-miller indices - slip - dislocation - crystallization-frank-reed source - Structural parameters in high-temperature deformed metals - dislocation structure - distances between dislocations in sub-boundaries - sub-boundaries as dislocation sources and obstacles -dislocations inside sub-grains - vacancy loops and helicoids - structural peculiarities of high - temperature deformation.

### MODULE - II

Characteristics of high-temperature materials - The super alloys as high-temperature materials- The

requirement: the gas turbine engine- Larson–Miller approach for the ranking of creep performance- development of the super alloys- Nickel as a high-temperature material: justification- super alloy production methods:- vacuum induction melting (VIM), vacuum arc remelting (VAR), VIM, electroslag remelting (ESR), VIM, ESR, VAR- Freckles, three rings, white spot- cleanliness.

### **MODULE - III**

Superalloys:- metallurgy, characteristics - wrought, cast superalloys, properties - crystal structures, phases in superalloys, Iron-Nickel-base superalloys, Nickel-base superalloys, Cobalt-base superalloys, - elements causing brittle phase formation, detrimental tramp elements, elements producing oxidation and hot corrosion resistance- microstructure, gamma prime, gamma double prime, Carbide and Boride phases, strengthening mechanisms- Heat treatment.

### **MODULE - IV**

Single-crystal super alloys for blade applications:- solidification, heat transfer, defects - mechanical behavior, performance in creep, fatigue - Titanium: binary phase diagram - production of ingot - forgings - shear bands - pickling - Ti alloys - machining and welding of Titanium - Heat Treatment - properties of titanium aluminides - Niobium: production of niobium - niobium in steel making - niobium alloys characteristics and applications- Niobium products for the superalloy industry.

### **MODULE - V**

Molybdenum: Ferromolybdenum - production of molybdenum – properties - effect of molybdenum alloying– applications - TZM, TZC- Maraging steel:- reaction in austenite - austenite to martensite transformation- reaction in martensite - time of maraging - precipitate size - fracture toughness - welding and ageing attributes - superior features - applications - cobalt free maraging steel - intermetallics:- phase diagrams- Hume-Rothery phases- structures of  $MgCu_2$ ,  $MgZn_2$ ,  $MgNi_2$ .

### **Text Books**

1. Callister William. D., Material Science and Engineering, John Wiley, 2014
2. Matthew J. Donachie, Stephen J. Donachie, Super alloys A Technical Guide, Second Edition, 2002 ASM International.

### **Reference**

1. Barrett, C. S. and Massalski, T. B. Structure of metals, Third edition. New York, N.Y., McGraw-Hill Book Company, 1966.
2. Decker, Raymond Frank, Source book on maraging steels: A comprehensive collection of outstanding articles from the periodical and reference literature, Published by American Society for Metals (1979).
3. Gerd Lutjering James C. Williams, Titanium, springer.
4. Roger C. Reed, The Super alloys Fundamentals and Applications, Cambridge university press.
5. Valim Levitin - High temperature strain of metals and alloys - physical fundamentals, Wiley-VCH (2006).
6. <https://www.phase-trans.msm.cam.ac.uk/teaching.html>

## MODEL QUESTION PAPER

### MATERIALS IN MANUFACTURING - (HONORS) - MET -296

Max. Marks : 100

Duration : 3 Hours

#### Part – A

Answer all questions.

Answer all questions, each question carries 3 marks

1. NASA's Parker solar probe will be the first-ever mission to "Touch" the Sun. The spacecraft, about the size of a small car, will travel directly into the Sun's atmosphere about 4 million miles from the earth surface. Postulate the coolant used in the Parker solar probe with chemical bonds.
2. Explain the structural parameters in time and creep curve for Nickel.
3. Explain the characteristics required for high-temperature materials
4. Explain the ways and means to improve super alloy cleanliness
5. What are the elements causing brittle phase formation in super alloys.
6. Explain the process and need of stress relieving used for super alloys
7. The preferred growth direction of a single-crystal superalloy is (100) Why?
8. Where is hundred percentage pure Titanium is used?
9. What are the special attributes of margin steel welded joint after ageing process?
10. How the structure of intermetallics are determined ?

#### PART -B

Answer one full question from each module.

##### MODULE -1

11. a. Explain the basic mechanism involved for metal deformation (7 marks).  
b. Explain process involved in high temperature strain of metals and alloys (7 marks).

#### OR

12. What are the roles played by the fan, compressor, combustor and turbine arrangements in a typical gas turbine engine? How do these affect (i) the pressure and (ii) the average temperature of the gas stream? Explain why your findings justify the use of nickel based superalloys in the combustor and turbine sections, but not in the compressor regions (14 marks).

##### MODULE -2

13. Explain the justification for the development of super alloys as high temperature alloys (14 marks).

#### OR

14. Explain the conditions of freckles, three rings and white spots formation and its implications (14 marks).

##### MODULE -3

15. Explain with neat sketches of different strengthening mechanisms of super alloys with its microstructure (14 marks).

#### OR

16. Explain different types of heat treatments employed for super alloys (14 marks).

##### MODULE -4

17. The materials used for high-pressure turbine blade aerofoils are often referred to as single-crystal superalloys. Explain why the use of the term 'single-crystal' is disingenuous (14 marks).

#### OR

18. Explain the process of closed die forging for Titanium alloy manufacturing (14 marks).

**MODULE -5**

19a. Explain the different reaction in austenite in maraging steel (7 marks).

19b. Explain the Maraging steel hardness produced with aging time versus aging time and different temperatures with neat sketches (7 marks).

**OR**

20a. Explain the synergetic effect of cobalt and molybdenum in maraging steel with graphs and sketch (7 marks).

20b. Explain structures of  $MgCu_2$ ,  $MgZn_2$ ,  $MgNi_2$  with neat sketches (7 marks).

**Course content and lecture schedules.**

Module	TOPIC	No. of hours	Course outcomes
1.1	Earlier and present development of atomic structure- Primary bonds: Secondary bonds - crystallography-miller indices- slip- crystallization - frank reed source	1	CO1
1.2	Structural parameters in high-temperature deformed metals: structural parameters.	2	CO1
1.3	Dislocation structure - distances between dislocations in sub-boundaries - sub-boundaries as dislocation sources and obstacles.	3	CO1
1.4	Dislocations inside sub-grains - vacancy loops and helicoids - structural peculiarities of high-temperature deformation (levitin).	3	
2.1	Characteristics of high-temperature materials - The superalloys as high-temperature materials.	3	CO1 CO2
2.2	The requirement: the gas turbine engine- Larson–Miller approach for the ranking of creep performance		
2.3	Development of the super alloys- Nickel as a high-temperature material: justification. (Reed).	2	CO2
2.4	Super alloy production methods:- melt routes for super alloys, characteristics, process parameters, application of each process Vacuum induction melting (VIM), Vacuum arc remelting (VAR), VIM, electroslag remelting (ESR),VIM, ESR, VAR.	3	CO2 CO3
2.5	Freckles, conditions of freckles, three rings, white spot- Super alloy cleanliness: ways and means to improve super alloy cleanliness, advantages of improved cleanliness, homogenization oxide cleanliness. (ASM).	2	CO3
3.1	Superalloys:- metallurgy of superalloys, superalloy characteristics - applications - service temperatures for superalloys.	1	CO2



3.2	Wrought superalloys, cast superalloys, properties of superalloys, mechanical properties and the application of superalloys, selecting superalloys.	1	CO2
3.3	Crystal structures, phases in superalloys, Iron-Nickel-base superalloys, Nickel-base superalloys, Cobalt-base superalloys, alloy elements and microstructural effects in superalloys, elements causing brittle phase formation, detrimental tramp elements, elements producing oxidation and hot corrosion resistance.	3	CO2
3.4	Microstructure, gamma prime, gamma double prime, Carbide and Boride phases, strengthening mechanisms: precipitate, gamma prime, gamma double prime, Carbides, M7C3 Carbides, Borides and other beneficial minor elements.	3	CO5
3.5	Heat treatment types:- stress relieving, annealing, quenching, precipitation, (ASM).	1	CO2
4.1	Single-crystal super alloys for blade applications:- directional solidification, heat transfer, formation of defects during directional solidification - mechanical behavior of the single-crystal super alloys, performance in creep, performance in fatigue (Reed).	3	CO4
4.2	Titanium: Ti-based binary phase diagram - production of ingot, Vacuum Arc Remelting - effect of forging temperature and forging pressure - closed die forgings - shear bands - pickling of titanium - Ti alloys - scrap recycling -problems in machining Titanium - welding of titanium - Heat Treatment of Ti - properties of titanium aluminides - applications.	4	CO2 CO5
4.3	Niobium: Production of niobium - niobium alloys - niobium in steel making – niobium alloys characteristics and applications- Niobium products for the superalloy industry.	2	CO2
5.1	Molybdenum: Ferromolybdenum - production of molybdenum – properties - effect of molybdenum alloying on hot strength, corrosion resistance, and toughness – applications - TZM, TZC.	2	CO2
5.2	Maraging steel:- Maraging steel chronology - reaction in austenite - austenite to martensite transformation- reaction in martensite - time of maraging - precipitate size - fracture toughness - welding and ageing attributes - superior features - applications - cobalt free maraging steel and comparisons.	4	CO2 CO4
5.3	Intermetallics:- Electronegativity, characteristics, property prediction - phase diagrams:- Magnesium - Lead, Copper – Zinc, Nickel -Titanium phase diagram - - The Hume-Rothery phases, electron phases /compounds, laves phases - Strukturbericht C15, C14, C36, etc - structures of MgCu <sub>2</sub> , MgZn <sub>2</sub> , MgNi <sub>2</sub> .	3	CO2 CO4

---

# SEMESTER V

---

COURSE CODE	COURSE NAME	CATEGORY	L	T	P	CREDITS
22MET501	MECHANICS OF MACHINERY	ES	3	1	0	4

**Preamble:**

This course aims to introduce the students to the fundamentals of the kinematics of various mechanisms and also its analysis for its displacement, velocity, and acceleration. The course will also cover the design of cams, theory and analysis of gears, gear trains and synthesis of mechanisms. The static force analysis of planar mechanisms and concept of gyroscopic couple along with its effect has also been included. This course also aids students in estimating unbalance in rotating and reciprocating masses and suggesting methods to overcome it.

**Prerequisite:** Engineering Mechanics (EST 100)

**Course Outcomes:** After the completion of the course the student will be able to

CO 1	Explain the fundamentals of kinematics, various planar mechanisms and interpret the basic principles of mechanisms and machines
CO 2	Perform analysis and synthesis of mechanisms
CO 3	Solve the problem on cams and gear drives, including selection depending on requirement.
CO 4	Calculate the gyroscopic effect in various situations
CO 5	Analyse rotating and reciprocating masses for its unbalance

**Mapping of course outcomes with program outcomes**

	PO 1	PO 2	PO 3	PO 4	PO 5	PO 6	PO 7	PO 8	PO 9	PO 10	PO 12
CO 1	2										
CO 2	3	3	3	2	2						
CO 3	3	3	2	2	2						
CO 4	3	2	1	1	1						
CO 5	3	2	2	1	2						

### Assessment Pattern

Bloom's Category	Continuous Assessment Tests		End Semester Examination
	1	2	
Remember	10	10	10
Understand	20	20	20
Apply	20	20	70
Analyse			
Evaluate			
Create			

### Mark distribution

Total Marks	CIE	ESE	ESE Duration
150	50	100	3 hours

### Continuous Internal Evaluation Pattern:

Attendance	: 10 marks
Continuous Assessment Test (2 numbers)	: 25 marks
Assignment/Quiz/Course project	: 15 marks

End Semester Examination Pattern: There will be two parts; Part A and Part B. Part A contain 10 questions with 2 questions from each module, having 3 marks for each question. Students should answer all questions. Part B contains 2 questions from each module of which student should answer any one. Each question can have maximum 2 sub-divisions and carry 14 marks.

### Course Level Assessment Questions

Course Outcome 1 (CO1): Explain the fundamentals of kinematics, various planar mechanisms and their components

1. Define the terms Link, Kinematic chain, Mechanism & Machine.
2. Explain Grashof's law.
- 3 Apply Kutzbach criterion to find the mobility of mechanisms.

4. Sketch and explain the various inversions of slider crank chain/fourbar chain

Course Outcome 2 (CO2) : Perform analysis and synthesis of mechanisms

1. Find out the velocity and acceleration of links of various planar mechanisms
2. State and prove the Arnold Kennedy's three centre theorem
2. Derive an expression for the magnitude and direction of Coriolis component of acceleration
3. Design a four bar mechanism to generate a given function accurate upto 3 positions
4. Do the static force analysis of four bar/slider crank mechanisms with different loading conditions

Course Outcome 3 (CO3): Solve the problem on cams and gear drives, including selection depending on requirement

1. Why is a roller follower preferred over knife edge follower
2. Design a cam profile to suit the situations for the follower such as SHM, dwell, constant velocity, uniform acceleration cycloidal motion etc
3. What do you understand by the term "interference" as applied to gears
4. Find out the gear train values of simple, compound and epicyclic gear trains

Course Outcome 4 (CO4): Calculate the gyroscopic effect in various situations

1. What do you understand by Gyroscopic couple? Derive its formula for its magnitude.
2. Explain the effect of the gyroscopic couple on the reaction of the four wheels of a vehicle negotiating a curve.
3. Describe the working of a gyroscope.
4. How does gyroscopes help in guidance?

Course Outcome 5 (CO5): Analyse rotating and reciprocating masses for its unbalance

1. Distinguish between static balancing and dynamic balancing
2. Find out the magnitude and position of balancing masses required to balance unbalanced masses rotating in different planes.
3. What do you mean by primary and secondary unbalanced forces?
4. Find out the value of unbalanced primary force, primary couple, secondary force and secondary couple.

## MODEL QUESTION PAPER

### FIFTH SEMESTER B. TECH DEGREE EXAMINATION

Course Code: MET301

Course Name: MECHANICS OF MACHINERY

Max. Marks: 100

Duration: 3 Hours

#### PART – A

(ANSWER ALL QUESTIONS, EACH QUESTION CARRIES 3 MARKS)

1. Find out the degree of freedom in the following cases.



a) A planar link

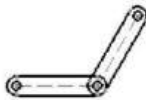

b) Two planar links joined by a revolute joint



c) Three Planar links joined by three revolute joints

2. Describe the motion of the following items as pure rotation, pure translation or complex planar motion.
- a) The hand of a clock b) The pen in an XY plotter c) connecting rod of an IC engine
3. A rod of length 1m with its one end fixed at origin is oriented in the positive X direction. It rotates in the XY plane with an angular velocity of  $10\text{rad/s}$  clockwise direction and angular acceleration of  $10\text{rad/s}^2$  in the counter clockwise direction at a particular instant. Find out the total acceleration experienced at the free end.
4. Obtain the expression for velocity when the cam follower motion is cycloidal in nature.
5. How do we bring interchangeability of gears?
6. What do you mean by type synthesis?
7. Define the term 'friction circle'
8. How does a gyroscope help in guidance of aircrafts?
9. Does a rotor which is statically balanced require dynamic balancing?

10. Why do we go for partial balancing in the case of balancing of reciprocating masses?

Part B

(ANSWER ONE FULL QUESTION FROM EACH MODULE)

MODULE – I

11. a) Draw the inversions of the mechanism shown in Figure 1 which leads to double crank, double rocker and crank rocker mechanisms. Describe the nature of motion of each link in each case also (9 marks)

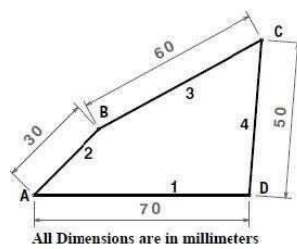

Figure-1

b) What are binary, ternary and quaternary links? (5 marks)

12. In the figure 2 given below the angular velocity of the crank OA is 600 r.p.m. Determine the linear velocity of the slider and angular velocity of all other links. The dimensions of various links are: OA=28 mm; AB = 44 mm; BC = 49 mm and BD = 46 mm. The centre distance between centres of rotation O and C is 65mm. The path of travel of slider is 11 mm below the fixed-point C (14 marks)

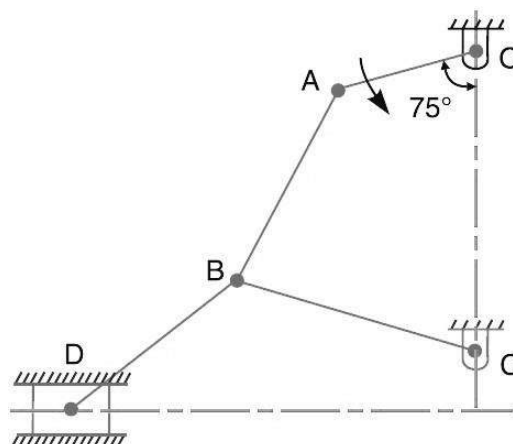

Figure-2

## MODULE – II

13. a) What is meant by Coriolis component of acceleration. In which case does it occur?

How is its direction determined? (9 marks)

b) A link OB rotating with a constant angular velocity of 2 rad/s in the counter clockwise direction and a block is sliding radially outwards on it with a uniform velocity of 0.75 m/s with respect to the rod as shown in the figure 3 below. Given OA = 1 m and link OB is inclined to the positive X axis by  $45^\circ$ . Find out the absolute acceleration of block at A in magnitude and direction. (5 marks)

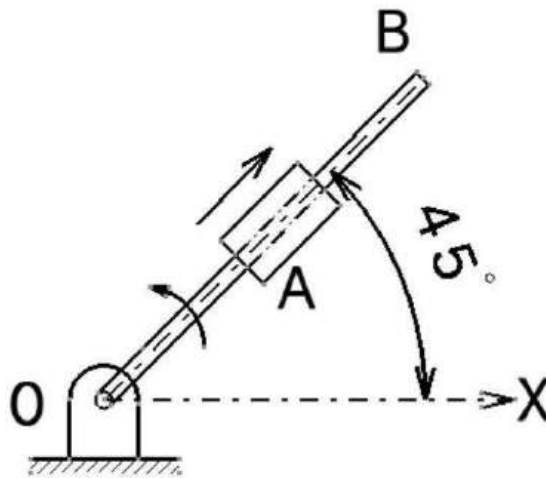

Figure-3

14. A cam rotating at 150 rpm operates a reciprocating follower of radius 2.5 cm. The follower axis is offset by 2.5 cm to the right. The least radius of the cam is 5 cm and the stroke of the follower is 5 cm. ascent and descent with take place by uniform acceleration and retardation. Ascent take place during  $75^\circ$  and descent during  $90^\circ$  of cam rotation. Dwell between ascent and descent is  $60^\circ$ . Draw the cam profile. Also sketch velocity and acceleration diagrams and mark salient values. (14 marks)

## MODULE – III

15. In an epicyclic gear train as shown in Figure 4 the internal wheels A and B and the compound wheels C & D rotate independently about axis O. The wheels E and F rotate on pins fixed to the arm G. E gears with A and C and F gears with B and D. All wheels have the same module and the number of teeth are:



$$T_C = 28, T_D = 26, T_E = T_F = 18$$

- i) Sketch the arrangement
- ii) Find the number of teeth on A and B
- iii) If the arm G makes 100 r.p.m clockwise and A is fixed, find the speed B
- iv) If the arm G makes 100 r.p.m clockwise and wheel A makes 10 r.p.m counter clockwise, find the speed of wheel B (14 marks)

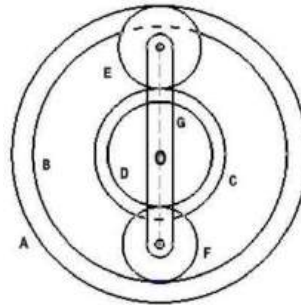

Figure-4

16. a) Design a four bar crank rocker to give  $45^\circ$  of rocker motion with a time ratio of 1:1.25 with  $45^\circ$  output rocker motion. (9 marks)
- b) Design a slider crank mechanism to coordinate two positions of the input link and the slider for the following angular and linear displacement of the input link and slider respectively.

$$\theta_{12} = 30^\circ \text{ \& } S_{12} = 100 \text{ mm} \quad \text{(5 marks)}$$

#### MODULE – IV

17. The applied load on the piston of an offset slider-crank linkage shown in Fig. is 100 N, and the coefficient of friction between the slider and the guide is 0.27, using any method, determine the magnitude and sense of torque  $T_2$  applied on OA for the static equilibrium of the linkage. (14 marks)

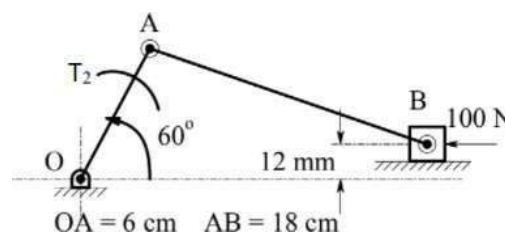

Figure-5

- 18 a) The wheels of a motor cycle have a moment of inertia of  $5 \text{ kg m}^2$  and the engine parts, a moment of inertia of  $0.35 \text{ kgm}^2$ . The wheel axles and the crank shaft of the engine are all parallel to each other. If the ratio of reduction gears is 4:1, the wheel diameter is 700 mm, determine the magnitude and direction of the gyroscopic couple when the motor cycle negotiates a curve of 50 m radius at a speed of 50 km/hr. If the mass of the motor cycle with rider is 250 kg with centre of gravity at 65 cm above the ground in vertical position, determine the speed of the motor cycle rounding a curve of 60 m if the road condition permits an angle of heel of  $45^\circ$ . (10 marks)
- b) Explain spin vector, precession vector, gyroscopic applied torque vector and gyroscopic reactive torque vector. (4 marks)

#### MODULE – V

19. A shaft carries four masses A, B, C and D which are placed in parallel planes perpendicular to the longitudinal axis. The unbalanced masses at planes B and C are 3.6 kg and 2.6kg respectively and both are assumed to be concentrated at a radius of 25mm while the masses in planes A and D are both at a radius of 40mm. The angle between the planes B and C is  $100^\circ$  and that between B and A is  $190^\circ$ , both angles being measured in counter clock wise direction from the plane B. The planes containing A and B are 250mm apart and those containing B and C are 500mm. If the shaft is to be completely balanced, determine

- i) Masses at the planes A and D
- ii) the distance between the planes C and D
- iii) the angular position of the mass D (14 marks)

20. A five cylinder in-line engine running at 750 r.p.m. has successive cranks  $144^\circ$  apart, the distance between the cylinder centre lines being 375 mm. The piston stroke is 225mm and the ratio of the connecting rod to the crank is 4. Examine the engine for balance of primary and secondary forces and couples. Find the maximum values of these and the position of the

central crank at which these maximum values occur. The reciprocating mass for each cylinder is 15 kg. (14 marks)

## Syllabus

### Module 1

Introduction to kinematics and mechanisms - various mechanisms, kinematic diagrams, degree of freedom- Grashof's criterion, inversions, coupler curves mechanical advantage, transmission angle. straight line mechanisms exact, approximate. Displacement, velocity analysis- relative motion - relative velocity. Instantaneous centre -Kennedy's theorem.

### Module 2

Acceleration analysis- Relative acceleration - Coriolis acceleration - graphical and analytical methods.

Cams - classification of cam and followers - displacement diagrams, velocity and acceleration analysis of SHM, uniform velocity, uniform acceleration, cycloidal motion Graphical cam profile synthesis, pressure angle.

### Module 3

Gears – Classification- terminology of spur gears – law of gearing -tooth profiles- involute spur gears- contact ratio - interference - backlash - gear standardization – interchangeability. Gear trains - simple and compound gear trains - planetary gear trains.

Kinematic synthesis (planar mechanisms) - type, number and dimensional synthesis – precision points. Graphical synthesis for motion - path and prescribed timing - function generator. 2 position and 3 position synthesis – overlay Method. Freudenstein's equation.

### Module 4

Static force analysis- Analysis of four bar linkages and slider crank mechanism, graphical method, Matrix method, principle of virtual work. Analysis of four bar and slider crank mechanisms with sliding and pin friction.

Gyroscopic couples-spin, precession and applied gyroscopic couple vectors-effects on the stability of two wheelers, four wheelers, sea vessels and air crafts, application of gyroscopes

### Module 5

Static balancing-dynamic balancing-balancing of several masses in the same plane-several masses in different planes-graphical and analytical method-force and couple polygons.

Balancing of reciprocating masses -Single cylinder engine-multi cylinder engine -V-engine

### Text Books

1. Ballaney P. L., Theory of Machines and Mechanisms, Khanna Publishers,2005
2. S. S. Rattan, Theory of Machines, Tata Mc Graw Hill,2009

### Reference Books

1. C. E. Wilson, P. Sadler, Kinematics and Dynamics of Machinery, Pearson Education,2005.
2. D.H. Myszka, Machines and Mechanisms Applied Kinematic Analysis, Pearson Education,2013
3. G. Erdman, G. N. Sandor, Mechanism Design: Analysis and synthesis Vol I & II, Prentice Hall of India,1984.
4. Ghosh, A. K. Malik, Theory of Mechanisms and Machines, Affiliated East West Press,1988
5. J. E. Shigley, J. J. Uicker, Theory of Machines and Mechanisms, McGraw Hill,2010
6. Norton, Kinematics and Dynamics of Machinery, Tata McGraw Hill,2009

### Course Contents and Lecture Schedule

No	Topic	No. of lectures
1	Module-1-	10 Hours
1.1	Introduction to kinematics and mechanisms	1 Hr
1.2	Various mechanisms	2 Hr
1.3	Kinematic diagrams, degree of freedom, Grashof's criterion	2 Hr
1.4	Inversions	1 Hr
1.5	Coupler curves mechanical advantage, transmission angle.	1 Hr
1.6	Straight line mechanisms exact, approximate	1 Hr
1.7	Displacement, velocity analysis, Kennedy's theorem.	2 Hr
2	Module 2-	10 Hours

2.1	Acceleration analysis- Relative acceleration - Coriolis acceleration -	1 Hr
2.2	Graphical and analytical methods.	2Hr
2.3	Cams - classification of cam and followers	1 Hr
2.4	Displacement diagrams, velocity and acceleration analysis of SHM,	2 Hr
2.5	Uniform velocity, uniform acceleration and cycloidal motion	1 Hr
2.5	Graphical cam profile synthesis, pressure angle.	2 Hr
2.6	Analysis of tangent cam with roller follower and circular cam with flat follower	1 Hr
3	Module-3	9 Hours
3.1	Gears – terminology of spur gears – law of Gearing	1 Hr
3.2	involute spur gears - contact ratio- interference - backlash - gear standardization-interchangeability	1 Hr
3.3	Gear trains - simple and compound gear trains - planetary gear trains	2 Hr
3.4	Kinematic synthesis (planar mechanisms) - type, number and dimensional synthesis – precision points.	2 Hr
3.5	Graphical synthesis for motion - path and prescribed timing - function generator. 2 position and 3 position synthesis	2 Hr
3.6	Overlay Method. Freudenstein's equation	1 Hr
4	Module-4-	8 Hours
4.1	Static force analysis- Analysis of four bar linkages and slider crank mechanism	2 Hr
4.2	Graphical method, Matrix method	1 Hr
4.3	principle of virtual work	1 Hr
4.4	Analysis of four bar and slider crank mechanisms with sliding and pin friction.	1 Hr

4.4	Gyroscopic couples-spin, precession and applied gyroscopic couple vectors	2 Hr
4.5	Effects on the stability of two wheelers , Four wheelers, sea vessals and air crafts	1 Hr
5	Module-5- Kinematics-synthesis	8 Hours
5.1	Static balancing-dynamic balancing-	2 Hr
5.2	balancing of several masses in the same plane	1 Hr
5.3	several masses in different planes-graphical and analytical method	1 Hr
5.4	force and couple polygons	1 Hr
5.5	Balancing of reciprocating masses -Single cylinder engine	1 Hr
5.6	multi cylinder engine-v engine-inline engine	2 Hr

COURSE CODE	COURSE NAME	CATEGORY	L	T	P	CREDITS
22MET502	THERMAL ENGINEERING	ES	3	1	0	4

Preamble: This course involve the application of principles studied in thermodynamics to different energy conversion systems like steam turbine, steam nozzle, steam powerplant, IC engines and refrigeration systems. This course also covers the methods for improving and evaluating the performance of different energy conversion systems. This course also helps to understand the combustion phenomenon in IC engines.

Prerequisite: MET202 Engineering Thermodynamics

Course Outcomes: After the completion of the course the student will be able to

CO 1	Explain the working of steam power cycle and related components
CO 2	Discuss the working of steam turbines and methods for evaluating the performance
CO 3	Illustrate the performance testing and evaluation of IC engines
CO 4	Explain the combustion phenomenon and pollution in IC engines
CO 5	Discuss the principles of refrigeration and air-conditioning and basic design considerations

Mapping of course outcomes with program outcomes

	PO 1	PO 2	PO 3	PO 4	PO 5	PO 6	PO 7	PO 8	PO 9	PO 10	PO 11	PO 12
CO 1	3	3	2									
CO 2	3	3	2									
CO 3	3	3	2									
CO 4	3	3	2									
CO 5	3	3	2									

Assessment Pattern

Bloom's Category	Continuous Assessment Tests		End Semester Examination
	1	2	
Remember	10	10	10
Understand	20	20	20
Apply	20	20	70
Analyse			
Evaluate			
Create			

Mark distribution

Total Marks	CIE	ESE	ESE Duration
150	50	100	3 hours

### Continuous Internal Evaluation Pattern:

Attendance	: 10 marks
Continuous Assessment Test (2 numbers)	: 25 marks
Assignment/Quiz/Course project	: 15 marks

End Semester Examination Pattern: There will be two parts; Part A and Part B. Part A contain 10 questions with 2 questions from each module, having 3 marks for each question. Students should answer all questions. Part B contains 2 questions from each module of which student should answer any one. Each question can have maximum 2 sub-divisions and carry 14 marks.

### Course Level Assessment Questions

#### Course Outcome 1 (CO1):

1. In a reheat Rankine cycle, steam at a pressure of 40 bar and 300°C is expanded through a turbine to a pressure of 4 bar. It is then heated at a constant pressure to 300°C and then expanded to 0.1 bar. Estimate the work done per kg of steam flowing through the turbine, the amount of heat supplied during the reheat process and the cycle efficiency. Neglect pump work.
2. Dry saturated steam enters a frictionless adiabatic nozzle with negligible velocity at a temperature of 300 °C. It is then expanded to a pressure of 40 bar. For a mass flow rate of 2 kg/s, calculate the exit velocity of the steam.
3. With the help of a figure explain the working of Babcock and Wilcox boiler.

#### Course Outcome 2 (CO2):

1. In an impulse steam turbine, steam issues from the nozzle with a velocity of 1200 m/s. The nozzle angle is 20° and the mean blade velocity is 400 m/s. The inlet and outlet blade angles are equal. The blade velocity coefficient is 0.8. The mass of steam flowing through the turbine per hour is 950 kg. Calculate: (i) Blade angles. (ii) Relative velocity of steam entering the blades (iii) Tangential force on the blades. (iv) Power developed. (v) Blade efficiency.
2. In a reaction turbine, the mean blade speed is 150 m/s and the ratio of blade speed to steam speed is 0.625. The outlet angles of fixed and moving blades are 20° and 30° respectively. Calculate (i) the degree of reaction (ii) the adiabatic enthalpy drop in a pair of blade rings and (iii) the gross stage efficiency. The specific volume of steam at fixed blade outlet is 0.567 m<sup>3</sup> and at moving blade outlet 0.6 m<sup>3</sup>. Assume the efficiency of blades when considered as nozzles 0.90 and  $k^2 = 0.86$ , where k is the blade velocity coefficient.
3. Derive the conditions for maximum efficiency of a Parsons reaction turbine.



4. Discuss the means of improving the performance of a steam turbine.

Course Outcome 3(CO3):

1. A 4-cylinder four stroke petrol engine is working based on the following data: Air-fuel ratio by weight = 15:1, calorific value of the fuel = 45000 kJ/kg, mechanical efficiency = 80 %, air- standard efficiency = 54 %, relative efficiency = 70 %, volumetric efficiency = 75 %, stroke/bore ratio = 1.25, suction conditions = 1 bar and 30 °C, r.p.m. = 2500, brake power = 70 kW. Calculate: (i) Compression ratio. (ii) Indicated thermal efficiency. (iii) Brake specific fuel consumption. (iv) Bore and stroke.
2. Discuss the working of a rotary engine and its merits and demerits over conventional IC engines.
3. How Morse test and retardation test helps to find the friction power of an engine?
4. Explain the procedure for heat balance test and its significance.

Course Outcome 4 (CO4):

1. Explain equivalence ratio and its significance in IC engine combustion.
2. Explain different stages of SI engine combustion with the help of pressure-crank angle diagram.
3. Discuss detonation in SI engine, cause and effects and the engine variable influencing the same.
4. Explain different pollution control methods employed for reducing the emissions in IC engines.

Course Outcome 5 (CO5):

1. Derive the expression for COP of an ideal air refrigeration cycle.
2. A food storage locker with R12 refrigerant requires a refrigeration of 2400 kJ/min. capacity has an evaporator temperature of 263 K and a condenser temperature of 303 K. The refrigerant is sub cooled by 6 °C before entering the expansion valve and vapour is superheated by 7 °C before leaving the evaporator coil. The refrigeration compressor is a two cylinder single acting with stroke equal to 1.25 times the bore and operates at 1000 rpm. Calculate i) Mass of refrigerant circulated/min. ii) Heat removed by condenser/min iii) Theoretical bore and stroke.
3. Sensible and latent loads on a space are 50 kW and 10 kW respectively. Cold and dehumidified air at 10 °C DBT and 90 % RH is used to maintain the space condition at 24 °C DBT. Find i) RSHF ii) space relative humidity and iii) mass flow rate of supply air?

# MODEL QUESTION PAPER

## V SEMESTER BTECH DEGREE EXAMINATION

### MET303: THERMAL ENGINEERING

Maximum: 100 Marks

Duration:3 hours

*Use of Steam tables, Refrigeration tables, Charts and Psychrometric chart is permitted.*

#### PART A

Answer all questions, each question carries 3 marks

1. Explain Rankine cycle with help of a T-S diagram.
2. Differentiate between fire tube boiler and water tube boiler.
3. List the difference between throttle governing and nozzle governing.
4. Explain degree of reaction of a steam turbine.
5. With the help of a diagram explain turbocharging.
6. Explain the procedure of Morse test.
7. Discuss about pollutants coming from a CI engine.
8. What do you meant by Octane number?
9. Why reversed Carnot cycle is practically impossible to execute?
10. Define bypass factor and mention its significance. (10×3=30 Marks)

#### PART B

Answer one full question from each module

#### MODULE 1

11. a) Steam at a pressure of 15 bar and 250 °C is expanded through a turbine to a pressure of 4 bar. It is then reheated at constant pressure to initial temperature of 250 °C and finally expanded to condenser pressure of 0.1 bar. Calculate efficiency of the cycle. What will be the efficiency if reheating is not employed? Pump work can be neglected. (8 marks)
- b) Derive the expression for mass flow rate of steam through a nozzle and obtain the critical pressure ratio. (6 marks)

12. a) With the help of a neat figure explain the working of a Benson boiler. What are its merits over other boilers? (8 marks)
- b) With the help of T-s and p-h diagram explain the significance of binary vapour cycle. (6 marks)

## MODULE 2

13. a) Derive the condition for maximum efficiency of a reaction turbine. (6 marks)
- b) With the help of figures enumerate the difference between pressure compounding and velocity compounding of steam turbines. (8 marks)
14. a) What do you mean by reheat factor? List the parameters influencing the value of reheat factor. (4 marks)
- b) In an impulse steam turbine, steam issues from the nozzle with a velocity of 1200 m/s. The nozzle angle is  $20^\circ$  and the mean blade velocity is 400 m/s. The inlet and outlet blade angles are equal. The blade velocity coefficient is 0.8. The mass of steam flowing through the turbine per hour is 950 kg. Calculate: (i) Blade angles. (ii) Relative velocity of steam entering the blades. (iii) Tangential force on the blades. (iv) Power developed. (v) Blade efficiency. (10 marks)

## MODULE 3

15. a) With the help of a neat figure explain the working of Wankel engine. Mention its merits and demerits over conventional IC engines. (9 marks)
- b) Discuss the effect of variable specific heat in actual cycle of IC engines. (5 marks)
16. a) The following observations were recorded during a trial of a four stroke single cylinder diesel engine for a trial duration of 30 min. Fuel consumption is 4 liters, Calorific value of fuel 43 MJ/kg, specific gravity of the fuel = 0.8, average area of indicator diagram =  $8.5 \text{ cm}^2$ , length of indicator diagram = 8.5 cm, spring constant = 5.5 bar/cm, brake load = 150 kg, spring balance reading = 20 kg, effective brake wheel diameter = 1.5 m, speed = 200 rpm, cylinder diameter = 30 cm, stroke = 45 cm. Calculate i) indicated power ii) brake power iii) mechanical efficiency iv) specific fuel consumption in kg/kWh and v) indicated thermal efficiency. (10 marks)
- b) Explain the concept of charge stratification in IC engines. (4 marks)

#### MODULE 4

17. a) With the help of pressure-crank angle diagram explain different stages of CI engine combustion. (8 marks)
- b) Explain the phenomenon of detonation in SI engine based on autoignition theory. (6 marks)
18. a) With the help of figures compare different types of SI engine combustion chambers. (8 marks)
- b) Discuss any two emission control methods employed in reducing the emission of CI engine. (6 marks)

#### MODULE 5

19. a) A freezer of 20 TR capacity has evaporator and condenser temperature of  $-30\text{ }^{\circ}\text{C}$  and  $25\text{ }^{\circ}\text{C}$  respectively. The refrigerant R-12 is sub-cooled by  $4\text{ }^{\circ}\text{C}$  before entering the expansion valve and is superheated by  $5\text{ }^{\circ}\text{C}$  before entering the evaporator. If a six cylinder single acting compressor with stroke equal to bore running at 1000 rpm. is used. Determine i) COP ii) Theoretical piston displacement per minute iii) Theoretical bore and stroke. (9 marks)
- b) Derive an expression for COP of a Reversed Brayton cycle for air refrigeration system. (5 marks)
20. a) 2.5 kg of air is cooled and dehumidified from  $30\text{ }^{\circ}\text{C}$  DBT, 40% RH to  $15\text{ }^{\circ}\text{C}$  DBT & 80% RH in a cooling and dehumidifying coil. Find (i) ADP, (ii) Bypass Factor and (iii) Heat Transfer. If bypass factor is halved keeping the ADP same find (iv) exit air condition and (v) Heat Transfer. (10 marks)
- b) Define i) DPT ii) RH ii) SHF and iv) ADP. (4 marks)

# Syllabus

## Module 1

Steam engineering- Rankine cycle, Modified Rankine cycle, Relative efficiency, Improvement in steam cycles-Reheat, Regenerative and Binary vapour cycle. Steam Boilers: Types of boilers, Cochran boiler, Babcock and Wilcox boiler, Benson boiler, La Mont boiler, Loeffler boiler, Velox boiler, Boiler Mountings and Accessories. Steam nozzles: -Types of nozzle, Velocity of steam, mass flow rate, critical pressure ratio and its significance, effect of friction, super saturated flow.

## Module 2

Steam turbines: classification, compounding of turbines-pressure velocity variation, velocity diagrams, work done, efficiency, condition for maximum efficiency, multistage turbines-condition line, stage efficiency. Steam turbine performance-reheat factor, degree of reaction, cycles with reheating and regenerative heating, governing of turbines.

## Module 3

Actual cycle analysis of IC engines- Deviation of actual engine cycle from ideal cycle, variable specific heats. Rotary engines, Stratified charge engine, Super charging and turbo charging. Performance Testing of I C Engines- Indicator diagram, mean effective pressure. Torque, Engine power- BHP, IHP. Engine efficiency, mechanical efficiency, volumetric efficiency, thermal efficiency, relative efficiency and Specific fuel consumption. Morse test, Heat balance test and Retardation test.

## Module 4

Combustion in I.C. Engines- Analysis of fuel combustion-A/F ratio, equivalence ratio, excess air. Combustion phenomena in S.I. engines; Ignition limits, stages of combustion in S.I. Engines, Ignition lag, velocity of flame propagation, auto ignition, detonation; effects of engine variables on detonation; theories of detonation, octane rating of fuels; pre-ignition; S.I. engine combustion chambers. Combustion in C.I. Engines; delay period; variables affecting delay period; knock in C.I. engines, Cetane rating; C.I. engine combustion chambers. Air pollution from I.C. Engine and its control: Pollutants from S.I. and C.I. Engines, Methods of emission control.

## Module 5

Refrigeration- Reversed Carnot cycle, Air refrigeration system- Reversed Joule cycle. Vapour compression systems-simple cycle - representation on T- s and P- h Diagrams. Effect of operating parameters on COP, Methods of improving COP of simple cycle, Super heating and under cooling. Psychrometric properties – specific humidity, relative humidity and degree of saturation, thermodynamic equations, enthalpy of moisture, DBT, WBT and DPT, psychrometers, psychrometric chart. Psychrometric processes- adiabatic mixing, sensible heating and cooling, humidifying and dehumidifying, air washer, bypass factor, sensible heat factor, Comfort and industrial air conditioning, Comfort air conditioning- factors affecting

human comfort, Effective temperature, comfort chart, Summer air conditioning, factors affecting, cooling load estimation.

#### Text Books

1. Rudramoorthy , Thermal Engineering, McGraw Hill Education India, 2003.
2. R.K Rajput, Thermal Engineering, Laxmi publications, 2010.
3. Arora C. P, Refrigeration and Air-Conditioning, McGraw-Hill, 2008.
4. Arora S. C. and Domkundwar, Refrigeration and Air-Conditioning, Dhanpat Rai, 2010.

#### Reference Books

1. V. Ganesan, Fundamentals of IC engines, Tata McGraw-Hill, 2002.
2. J.B.Heywood, I.C engine fundamentals. McGraw-Hill, 2011.
3. Rathore, Thermal Engineering, McGraw Hill Education India, 2010.
4. Dossat. R. J, Principles of Refrigeration, Pearson Education India, 2002.
5. Stoecker W.F, Refrigeration and Air-Conditioning, McGraw-Hill Publishing Company, 2009.

#### Course Contents and Lecture Schedule

No	Topic	No. of Lectures
1		
1.1	Steam engineering- Rankine cycle, Modified Rankine cycle, Relative efficiency, Improvement in steam cycles-Reheat, Regenerative and Binary vapor cycle.	4
1.2	Steam Boilers: Types of boilers, Cochran boiler, Babcock and Wilcox boiler, Benson boiler, , La Mont boiler, Loeffler boiler, Velox boiler, Boiler Mountings and Accessories.	3
1.3	Steam nozzles:-Types of nozzle- Velocity of steam, mass flow rate, critical pressure ratio and its significance, effect of friction, super saturated flow.	2
2		
2.1	Steam turbines: classification, compounding of turbines-pressure velocity variation, velocity diagrams.	3
2.2	Work done, efficiency, condition for maximum efficiency, multistage turbines-condition line, stage efficiency.	3
2.3	Steam turbine performance-reheat factor, degree of reaction, cycles with reheating and regenerative heating, governing of turbines.	3
3		

3.1	Actual cycle analysis of IC engines- Deviation of actual engine cycle from ideal cycle, variable specific heats.	2
3.2	Rotary engines, Stratified charge engine, Super charging and turbo charging.	2
3.3	Performance Testing of I C Engines- Indicator diagram, mean effective pressure. Torque, Engine power- BHP, IHP. Engine efficiency, mechanical efficiency, volumetric efficiency, thermal efficiency and relative efficiency, Specific fuel consumption.	3
3.4	Morse test, Heat balance test and Retardation test.	2
4		
4.1	Combustion in I.C. Engines- Analysis of fuel combustion-A/F ratio, equivalence ratio, excess air.	1
4.2	Combustion phenomena in S.I. engines; Ignition limits, stages of combustion in S.I. Engines, Ignition lag, velocity of flame propagation, auto ignition, detonation; effects of engine variables on detonation; theories of detonation, octane rating of fuels; pre-ignition; S.I. engine combustion chambers.	3
4.3	Combustion in C.I. Engines; delay period; variables affecting delay period; knock in C.I. engines, Cetane rating; C.I. engine combustion chambers.	3
4.4	Air pollution from I.C. Engine and its control: Pollutants from S.I. and C.I. Engines, Methods of emission control.	2
5		
5.1	Refrigeration– Reversed Carnot cycle, Air refrigeration system- Reversed Joule cycle.	2
5.2	Vapour compression systems-simple cycle - representation on T- s and P- h Diagrams. Effect of operating parameters on COP, Methods of improving COP of simple cycle, Super heating and under cooling.	2
5.3	Psychrometric properties – specific humidity, relative humidity and degree of saturation- thermodynamic equations- enthalpy of moisture- DBT, WBT and DPT–psychrometers, psychrometric chart.	1
5.4	Psychrometric processes- adiabatic mixing, sensible heating and cooling, humidifying and dehumidifying, air washer, bypass factor, sensible heat factor.	2
5.5	Comfort and industrial air conditioning, Comfort air conditioning- factors affecting human comfort, Effective temperature, comfort chart, Summer air conditioning, factors affecting, cooling load estimation.	2

COURSE CODE	COURSE NAME	CATEGORY	L	T	P	CREDITS
22MET503	INDUSTRIAL & SYSTEMS ENGINEERING	ES	3	1	0	4

### Preamble:

This course is designed to facilitate the students to acquire knowledge about management principles and practices of an industry. It empowers the students to amalgamate their knowledge of materials management, inventory management, lean manufacturing, agile manufacturing, industrial relations and enterprise resource planning and thus inculcate the skills needed to apply these principles in an industry.

Prerequisite: NIL

Course Outcomes: After the completion of the course the student will be able to

CO 1	Implement various tools and techniques in industrial engineering
CO 2	Calculate the inventory system for a given requirement
CO 3	Explain the importance of industrial relations
CO 4	Select the lean manufacturing tools to find and eliminate wastes
CO 5	Identify the framework of agile manufacturing
CO 6	Identify core and extended modules of enterprise resource planning

Mapping of course outcomes with program outcomes

	PO 1	PO 2	PO 3	PO 4	PO 5	PO 6	PO 7	PO 8	PO 9	PO 10	PO 11	PO 12
CO 1	2				2				2		2	2
CO 2	3			2						2	2	2
CO 3						1			2	2	1	2
CO 4	2	1		2	1						2	2
CO 5				2	1				2		2	2
CO 6	2				3						2	2

### Assessment Pattern

Bloom's Category	Continuous Assessment Tests		End Semester Examination
	1	2	
Remember	10	10	20
Understand	20	40	60
Apply	20		20
Analyse			
Evaluate			
Create			

### Mark distribution

Total Marks	CIE	ESE	ESE Duration
150	50	100	3 hours



### Continuous Internal Evaluation Pattern:

Attendance	: 10 marks
Continuous Assessment Test (2 numbers)	: 25 marks
Assignment/Quiz/Course project	: 15 marks

End Semester Examination Pattern: There will be two parts; Part A and Part B. Part A contain 10 questions with 2 questions from each module, having 3 marks for each question. Students should answer all questions. Part B contains 2 questions from each module of which student should answer any one. Each question can have maximum 2 sub-divisions and carry 14 marks.

### Course Level Assessment Questions

#### Course Outcome 1 (CO1):

1. Calculate the breakeven point for the product.
2. What are the functions of Industrial Engineering?
3. What are the human factors to be considered while designing a new product?

#### Course Outcome 2 (CO2)

1. List various types of material handling equipments
2. Determine the optimum quantity to be ordered
3. Describe the role played by the materials management function in enabling an organisation to achieve profitability.

#### Course Outcome 3(CO3):

1. Define 'Job Satisfaction'.
2. Describe the causes of poor industrial relations.
3. What is meant by 'collective bargaining'?

#### Course Outcome 4 (CO4):

1. Compare the inventory levels in conventional and lean manufacturing systems.
2. Expand the Japanese terms of 5S
3. Describe the basic elements of lean manufacturing

#### Course Outcome 5 (CO5):

1. Describe the components of agile manufacturing system
2. List the measures that are used to measure innovation in agile production system.
3. How do strategic linkages aid the organisation to acquire agility?

#### Course Outcome 6 (CO6):

1. Enumerate ERP implementation stages.
2. With the aid of a block diagram, explain the construction and working of ERP framework.
3. Describe ERP related technology

Model Question paper

APJ ABDUL KALAM TECHNOLOGICAL UNIVERSITY

FIFTH SEMESTER B.TECH DEGREE EXAMINATION

MET305 INDUSTRIAL & SYSTEMS ENGINEERING

Max. Marks: 100

Duration: 3 Hours

PART A

Answer ALL questions, each carries 3 marks.

1. What are the human factors to be considered while designing a new product?
2. Describe the procedure followed while designing a product.
3. List various types of material handling equipments
4. Describe the concept of JIT manufacturing system
5. Describe the causes and effects of industrial disputes and how it can be eliminated
6. What are the methods of elimination of fatigue?
7. Expand the Japanese terms of 5S.
8. Describe the characteristics of agile manufacturing.
9. State the evolution of ERP.
10. What is Online Analytical Processing?

PART B

Module 1

11. a) How inventories are classified and costs associated by inventories? (5)  
b) A manufacturer has to supply 10,000 units of product annually. The unit cost is Rs. 2 and it costs Rs.36 to place an order. The inventory carrying cost is estimated at 9% of average inventory investment. Determine 1. EOQ 2.Optimum number of orders to be placed per annum. 3. Minimum total cost of inventory (9)
- 12 a) What are the principles of good product design (10)  
b) The fixed cost of producing a product in a company is Rs. 8,00,000. Variable cost per unit of the product is Rs. 30. Each unit of the product is going to be sold at a price of Rs. 180. Determine the breakeven point of this product. (4)

## Module 2

13. Describe the role played by the materials management function in enabling an organisation to achieve profitability. (14)

14. a) What is meant by quantity discount? (4)

b) A retailer procures batteries for quartz watches and sells them to watch repair shops. The price paid by the retailer varies on the basis of the quantities of batteries procured by him. The quantity and the price/unit pattern offered to him are given below:

Quantity (Q)	Price per one unit of battery
$0 \leq Q < 100$	Rs.20
$100 \leq Q < 200$	Rs.18
$200 \leq Q$	Rs.15

The monthly demand for the batteries is 600 units. The storage cost is 15% of unit cost of the battery and the cost of ordering is Rs.30 per order. Determine the optimum quantity to be ordered by the retailer so that the total cost of procurement is minimum. (10)

## Module 3

15. (a) List any five objectives of Trade union. (5)

(b) Trace the history of Trade unionism. (9)

16 (a) Explain conditions to be met for maintaining good industrial relations. (7)

(b) Describe the causes of poor industrial relations. (7)

## Module 4

17. (a) Enumerate the objectives and key principles of lean manufacturing paradigm. (7)

(b) Compare traditional and lean manufacturing paradigms. (7)

18. List and describe any ten components of agile manufacturing system. (14)

## Module 5

19. Describe the key processes of “Customer Relationship Management”. (14)

20 a) With the aid of a block diagram, explain the construction and working of ERP framework. (7)

(b) Explain the differences between 'Business Engineering' and 'Business Process Reengineering'. (7)

## Syllabus

### Module 1

Introduction to Industrial Engineering - Evolution of modern Concepts in Industrial Engineering - Functions of Industrial Engineering - Field of application of Industrial Engineering - Design function - Objectives of design- Development of designs- prototype, production and testing - Human factors in design - Principles of good product design- tolerance design- quality and cost considerations- product life cycle- standardization, simplification, diversification- concurrent engineering- comparison of production alternatives - Economic aspects- C-V-P analysis – simple problems.

### Module 2

Introduction to materials management – objectives – Types of material handling equipments - principles of material handling –Material selection – value analysis – make or buy decisions- Purchasing and procedures. Basic inventory management - Inventory -Functions, Costs, Classifications - EOQ Models- Assumptions- Quantity discount model- Q system- P system- Reorder level - Simple problems- Concept of JIT manufacturing system.

### Module 3

Industrial relations- Psychological attitudes to work and working conditions - fatigue- Methods of eliminating fatigue- Effect of Communication in Industry-Industrial safety-personal protective devices-, causes and effects of industrial disputes- Collective bargaining- Trade union - Workers participation in management.

### Module 4

Principles of Lean Manufacturing(LM) – Basic elements of LM– Introduction to LM Tools- Concept of wastes in LM and their narration - stages of 5S and waste elimination - Conventional Manufacturing versus Lean Manufacturing - Need for LM. Agile manufacturing - Definition, business need, conceptual frame work, characteristics, and generic features - Approaches to enhance ability in manufacturing - Managing people in agile organization

### Module 5

Introduction of enterprise resource planning (ERP)- Concept of Enterprise, ERP Overview - Integrated information system - Myths about ERP – Evolution of ERP- Benefits of ERP implementation - Success and failure factors of ERP implementation - Small, medium and large enterprise vendor solutions- ERP and related technology: Business intelligence (BI), E-Commerce and E-Business, Business Process Reengineering (BPR), Data warehousing, Data mining, Online Analytical Processing(OLAP), Product lifecycle management(PLC), Supply chain

management(SCM), Customer relationship management (CRM)- ERP implementation challenges - Emerging trends on ERP

### Text Books

1. Martand T. Telsang, “Industrial Engineering & Production Management”, S. Chand and Company Limited, 2018.
2. M. Mahajan, “Industrial Engineering & Production Management”, Dhanpat Rai & Co. (P) Limited, 2015.
3. O. P. Khanna, “Industrial Engineering and Management”, Dhanpat Rai Publications, 2018.
4. James P. Womack, Daniel T. Jones and Daniel Roos, “The Machine That Changed the World”, Free Press, New York, 2007.
5. Alexis Leon, “ERP Demystified”, Tata McGraw Hill Education Private Limited, New Delhi, 2008.

### Reference Books

1. Kjell Zandin and Harold Maynard, “Maynard's Industrial Engineering Handbook”, McGraw-Hill Education, 2001.
2. Philips E. Hicks, “Industrial Engineering and Management – A new perspective”, McGraw Hill International Editions, New York, 1994.
3. B. Kumar “Industrial Engineering and Management “, Khanna Publishers,2013.
4. S.R. Devadasan, V. Mohan Sivakumar, R. Murugesh and PR Shalij, “Lean and Agile Manufacturing: Theoretical, Practical and Research Futurities” PHI Learning private Limited, New Delhi, 2012.
5. Ravi Shankar, “Industrial Engineering and Management”, Golgotia Publications Pvt Ltd, NewDelhi, 2009.

### Course Contents and Lecture Schedule

No	Topic	No. of Lectures
1	Introduction to Industrial Engineering	
1.1	Evolution of modern Concepts in Industrial Engineering - Functions of Industrial Engineering - Field of application of Industrial Engineering	2
1.2	Design function - Objectives of design- Development of designs- prototype, production and testing - Human factors in design - Principles of good product design- tolerance design	2
1.3	Quality and cost considerations- product life cycle- standardization, simplification, diversification- concurrent engineering	2
1.4	Comparison of production alternatives - Economic aspects- C-V-P analysis – simple problems	2
2	Introduction to materials management	

2.1	Objectives – Types of material handling equipments	1
2.2	Principles of material handling –Material selection – value analysis	2
2.3	Make or buy decisions-Purchasing procedure	1
2.4	Inventory -Functions, Costs, Classifications	1
2.5	EOQ Models- Assumptions- Quantity discount model- Q system- P system- Reorder level - Simple problems, JIT	3
3	Industrial relations	
3.1	Psychological attitudes to work and working conditions	1
3.2	Fatigue- Methods of eliminating fatigue	1
3.3	Effect of Communication in Industry-Industrial safety-personal protective devices	2
3.3	Causes and effects of industrial disputes- Collective bargaining	2
3.4	Trade union - Workers participation in management	1
4	Lean Manufacturing and Agile manufacturing	
4.1	Principles of Lean Manufacturing(LM) – Basic elements of LM– Introduction to LM Tools	2
4.2	Concept of wastes in LM and their narration	1
4.3	Stages of 5S and waste elimination	2
4.4	Conventional Manufacturing versus Lean Manufacturing - Need for LM.	1
4.5	Agile manufacturing – Definition , business need	1
4.6	Agile manufacturing - conceptual frame work, characteristics, and generic features	2
4.7	Approaches to enhance ability in manufacturing -	1
4.8	Managing people in agile organization	1
5	Introduction of Enterprise Resource Planning	
5.1	Introduction of enterprise resource planning (ERP)- Concept of Enterprise, ERP Overview - Integrated information system - Myths about ERP – Evolution of ERP	2
5.2	Myths about ERP - Basic ERP concepts - Small, medium and large enterprise vendor solutions	2
5.3	Benefits of ERP implementation, Success and failure factors of ERP implementation	1
5.4	Business intelligence (BI), E-Commerce and E-Business, Business Process Reengineering (BPR)	2
5.5	Data warehousing, Data mining, Online Analytical Processing(OLAP), Product lifecycle management(PLC)	2
5.6	Supply chain management(SCM), Customer relationship management (CRM)	1
5.7	ERP implementation challenges, Emerging trends on ERP	1

COURSE CODE	COURSE NAME	CATEGORY	L	T	P	CREDITS
22MET504	MACHINE TOOLS AND METROLOGY	ES	3	1	0	4

**Preamble:**

To develop knowledge of appropriate process parameters to be used for various machining operations.

Understand the fundamentals of modern quality concepts. Be able to apply statistical techniques.

Understand the principles and operation of precision measurement tools and equipment used in modern manufacturing.

Prerequisite: MET 205 Metallurgy and Material Science and PHT 110 Engineering Physics

Course Outcomes - At the end of the course students will be able to

CO 1	Analyze various machining process and calculate relevant quantities such as velocities, forces and powers.
CO 2	Analyze of the tool nomenclature with surface roughness obtainable in each machining processes.
CO 3	Understand the limitations of various machining process with regard to shape formation and surface texture.
CO 4	Demonstrate knowledge of the underlying principles of measurement, as they relate to mechanical measurement, electronic instrumentation, and thermal effects.
CO 5	Get an exposure to advanced measuring devices and machine tool metrology.

Mapping of course outcomes with program outcomes (Minimum requirements)

	PO 1	PO 2	PO 3	PO 4	PO 5	PO 6	PO 7	PO 8	PO 9	PO 10	PO 11	PO 12
CO 1	2	3	-	-	-	-	-	-	-	-	2	1
CO 2	2	3	-	-	-	-	-	-	-	-	2	1
CO 3	2	1	-	2	2	-	-	-	-	-	-	2
CO 4	3	-	2	-	-	-	-	-	-	-	2	2
CO 5	2	-	-	2	3	-	-	-	-	-	-	3

## ASSESSMENT PATTERN

Bloom's taxonomy	Continuous Assessment Tests		End Semester Examination (Marks)
	Test 1 (Marks)	Test 11 (Marks)	
Remember	25	25	25
Understand	15	15	15
Apply	30	25	30
Analyze	10	10	10
Evaluate	10	15	10
Create	10	10	10

Mark distribution			
Total Marks	CIE marks	ESE marks	ESE duration
150	50	100	3 Hours
<b>Continuous Internal Evaluation (CIE) Pattern:</b>			
Attendance		10 marks	
Regular class work/tutorials/assignments/self learning (Minimum 3 numbers)		15 marks	
Continuous Assessment Test (Minimum 2 numbers)		25 marks	
<p>End semester pattern:-There will be two parts; Part A and Part B. Part A contain 10 questions with 2 questions from each module, having 3 marks for each question. Students should answer all questions. Part B contains 2 questions from each module of which student should answer anyone. Each question can have maximum 2 sub-divisions and carry 14 marks.</p>			
<b>COURSE LEVEL ASSESSMENT QUESTIONS</b>			
<p>Course Outcome 1 (CO1) Analyze various machining process and calculate relevant quantities such as velocities, forces and powers.</p>			
<ol style="list-style-type: none"> <li>List out various types of Lathe attachment explain</li> <li>Explain the working principle of slotter</li> <li>In a vernier calliper, the main scale reads in millimetres with a least count of 0.1 mm. Ten divisions on the vernier correspond to nine divisions of the main scale. Determine the</li> </ol>			



leastcount of the calliper.

4. A shaft is manufactured within the specified limits of 30.02 and 29.98 mm. Find the high and low limits of the bush to give a maximum clearance of 0.10 mm and minimum clearance of 0.02 mm.
5. What is the difference between rough grinding and precision grinding?

Course Outcome 2 (CO2): Analysis of the tool nomenclature with surface roughness obtainable in each machining processes.

1. Define the terms 'Cutting speed', 'feed' and 'depth of cut'?
2. How are abrasives selected for grinding operation?
3. Why a coolant used in grinding work?
4. How the grinding wheel is selected for a particular job?
5. Describe the nomenclature of hob.
6. Discuss the significant machining parameters for shaping machine.

Course Outcome 3 (CO3): Understand the limitations of various machining process with regard to shape formation and surface texture.

1. What is the difference between drilling, boring and reaming?
2. Explain any three thread production processes.
3. Explain counter sinking and trepanning.
4. Explain different types of gear hobbing machines.
5. Explain planning of guide gibs and slotting of keyways.

Course Outcome 4 (CO4): Students will demonstrate knowledge of the underlying principles of measurement, as they relate to mechanical measurement, electronic instrumentation, and thermal effects.

1. Describe the GO and NOGO gauge design procedure with neat sketch.
2. **Design general type GO and NO GO gauges for a 40H7/d8 fit. 40 mm lies in the diameter range 30 to 50. Show graphically the disposition of gauge tolerance zones relative to the work tolerance zones. Standard tolerance for IT7 is 16i and IT8 is 25i, where 'I' is the standard tolerance unit. The upper deviation for 'd' shaft is  $-16D^{0.44}$ .**
3. A 50 mm long pin having diameter  $20 \pm 0.02$  mm, will be electroplated for a thickness of  $50 \pm 5$   $\mu$ m. Estimate the size of a GO limit gauge, neglecting the gauge to tolerances.

Course Outcome 5 (CO5): Get an exposure to advanced measuring devices and machine tool metrology.

1. Is assessment length greater/lesser than transverse length in surface roughness measurements? Why?
2. A surface tested under an optical flat using interferometer shows the following interference fringe pattern. Interpret the nature of the surface.

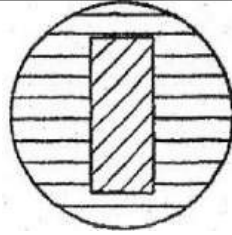

3. What are difference between  $R_t$  and  $R_z$  with neat sketches
4. How are CMM classified based on their construction? With neat sketches explain the merits and applications any one of them.

### MODEL QUESTION PAPER

#### FIFTH SEMESTER MECHANICAL ENGINEERING

#### MACHINE TOOLS AND METROLOGY-MET 307

Max. Marks: 100 Duration: 3 Hours

Part – A

Answer all questions.

Answer all questions, each question carries 3 marks

1. What is trepanning? Explain with sketch.
2. What are the use of face plate and angle plate in a lathe?
3. With a sketch, show rake angle of milling cutter and chip breaker.
4. What s the difference between grinding wheel dressing and truing
5. What is the principle of Gear shaping? Explain.
6. Write note on gear errors.
7. Differentiate between precision and accuracy.
8. Explain the process of wringing of slip gauges.
9. Write the importance of cut off length in surface roughness measurement
10. Explain the principle of measurement by light wave interference method.

PART –B

Answer one full question from each module.

#### MODULE – 1

11. a. What are the attachments used on a center lathe and what purpose do they serve? (7 marks).
- b. Draw a drillsignature, name the important angles and explain their each functionand explain plaining of guide gibs(7 marks).

12. Draw sketch of a crank shaper, mark the important parts and explain their functions. Explain how quick return mechanism works. (14 marks).

#### MODULE – 2

13. a. Explain the principle of working of centreless grinding machine. (7 marks).  
b. What are 'Through Feed', 'In Feed', and 'End Feed' in centreless grinding operations? (7 marks).
14. a. Explain in detail with neat sketches of a) Slot and groove milling, b) profile milling c) thread milling(7 marks).  
b. What is the need of better surface finish and how honing, lapping and burnishing process are different in its features and roughness obtainable, explain with sketches. (7 marks).

#### MODULE – 3

15. Why gear finishing processes are required? Write down the advantages and limitations of gear shaving and gear lapping process with neat sketches. (14 marks).
- 16 Describe the different methods of manufacturing various types of gears i. Preforming  
ii. Producing gear teeth by machining iii. Finishing gear teeth (14 marks).

#### MODULE – 4

- 17 Discuss all the principles of achieving accuracy. Explain all types of errors. (14 marks).
18. Determine limit dimensions for a clearance fit between mating parts of diameter 40 mm, providing a minimum clearance of 0.10 mm with a tolerance on the hole equal to 0.025mm and on shaft 0.05mm using both systems(14 marks).

#### MODULE – 5

- 19 a ) Define the following terms in surface texture measurements: -  
(i) Primary Texture.(ii) Secondary Texture.(iii) Lay(iv) Sampling Length.(7 marks).  
b) Describe the method of evaluating roughness using(i) Peak to valley high method.  
(ii) C.L.A. method. (7 marks).
- 20 a ) Discuss the different types of probes used in CMM (7 marks).  
b.) Explain the various steps in machine vision system (7 marks).

## SYLLABUS

### MODULE – 1

General purpose machine tools – types and classification of machine tools –types and classification of lathe – methods of holding work and tool –lathe accessories and attachments –lathe operations -tool room lathe – duplicate lathe –capstan and turret lathe –horizontal and vertical-single spindle and multi spindle screw machines - Shaping, Planing and Slotting machines – Work holding devices-types of operations - surface roughness obtainable indexing - Drilling and boring Machines – -Drill bit nomenclature- cutting forces in drilling – tool and work holding devices-boring tools and reamers.

### MODULE – II

Milling tool nomenclature - Cutting forces in milling – Calculation of machining time- Indexing head Different indexing methods -Grinding, honing and lapping – types of grinding machines-operations: cutting forces in grinding -Grinding mechanisms – Grinding wheels - surface roughness obtainable in grinding, honing and lapping.

### MODULE – III

Broaching machines –different machines – cutter for broaching – broaching processes – internal external broaching - Gear cutting –methods in gear production – form cutters –gear generating machines – gear hobbing machines – gear broaching -Bevel gear cutting –worm gear cutting –gear finishing.

### MODULE – IV

Metrology –principles of achieving accuracy -Theory of tolerances and allowances –system of limits and fits – types of fits – interchangeability and selective assembly –standards of measurements- Gauges – classification of gauges –principle of gauge tolerance –wear allowance.

### MODULE – V

Instruments for checking straightness, flatness and squareness–pneumatic gauging –precision gauging – automatic gauging for inspection-Optical measuring instruments –Comparators –Measurements of surface roughness – gauging and measurements of screw and gears- Advanced measuring devices – Laser interferometers- Coordinate Measuring Machine (CMM).

Text Books

1. Chapman W. A. J., Workshop Technology, Viva books (P) Ltd
2. HMT, Production Technology, Tata McGraw-Hill
3. Engineering Metrology and Measurements, N.V. Raghavendra, I. Krishnamurthy, Oxford University Press
4. Galyer J.F.W., Schotbolt C.R., Metrology for Engineers, ELBS.

Reference

1. Acharkan. N., Machine Tool Design Vol. 1 to 4, MIR Publication
2. Chernov, Machine Tools, MIR Publication.
3. HajraChoudary, Elements of workshop technology, Vol I & II, Media Publishers.
4. ASME, Hand book of Industrial Metrology.
5. Hume K. J., Engineering Metrology, Macdonald & Co. Ltd.
6. Sharp K.W.B., Practical Engineering Metrology, Sir Isaac Pitman & Sons Ltd.

COURSE CONTENT AND LECTURE SCHEDULES.

Module	TOPIC	No.of hours	Course outcomes
1.1	General purpose machine tools – types and classification of machine tools – Lathe – types and classification of lathe – specification for a lathe –	1	CO3
	Feed, depth of cut, speed-methods of holding work and tool – lathe accessories and attachments – lathe operations and tools used for each operations -	3	CO1
1.2	Brief study of the machine and the nature and type of jobs handled by the following: - tool room lathe – duplicate lathe – capstan and turret lathe – horizontal and vertical-single spindle and multi spindle screw machines.	3	CO2
1.3	Shaping, Planing and Slotting machines – Types and specifications – quick return motion – hydraulic feed and its advantages - automatic feed – speed, feed and depth of cut – Work holding devices-types of operations and examples of work done- surface roughness obtainable indexing (Self learning portion, discretion of faculty, fundamentals to be explained in the class)	1	CO3
1.4	Drilling and boring Machines – Types and specifications – Brief descriptions about the machines and nature, types of job	1	CO3

	handled by each of them.		
1.5	-Drill bit nomenclature- cutting forces in drilling – tool and work holding devices-boring tools and reamers.	1	CO2
2.1	Milling machines – types and specifications- Milling operations and types of milling cutters used for each.	1	CO3
2.2	- Milling tool nomenclature - Cutting forces in milling – Calculation of machining time- Indexing head and its use -	1	CO1 CO3
2.3	Different indexing methods - Differential indexing (Self learning portion discretion of faculty, fundamentals to be explained in the class)	1	
2.4	Grinding, honing and lapping – types of grinding machines- operations: cylindrical, surface and center less grinding – internal grinding, tool and cutter grinding - cutting forces in grinding	3	CO1 CO3
2.5	Grinding mechanisms – Grinding wheels: Specification – types of abrasives, grain size -Types of bond, grade, and structure – Marking system of grinding wheels – Selection of grinding wheels –need of better surface finish; surface roughness obtainable in grinding, honing, lapping and burnishing; Surface roughness comparisons between different conventional metal cutting processes.	3	CO3
3.1	Broaching machines –different machines – cutter for broaching – different broaching processes – internal external broaching.	3	CO3
3.2	Gear cutting –methods used in gear production – form cutters – gear generating machines – gear hobbing machines – gear broaching.	3	CO3
3.3	Bevel gear cutting – straight and spiral gears-worm gear cutting –gear finishing operations.	3	CO3
4.1	Metrology –principles of achieving accuracy –economic machining accuracy – precision Vs accuracy - errors- standards of measurements-	2	CO 4
4.2	Theory of tolerances and allowances –system of limits and fits – types of fits – interchangeability and selective assembly – Taylor’s Principle-	4	CO 4
4.3	Gauges – classification of gauges- plug, ring, taper angle, slip and snap gauges –feeler gauges-dial indicator –principle of gauge tolerance –wear allowance-gauge materials.	4	CO 4 CO 5
5.1	Instruments for checking straightness, angle, flatness and squareness of guiding surface(Self learning portion, discretion of faculty, fundamentals to be explained in the class). – pneumatic gauging –precision gauging –automatic gauging for inspection.	2	CO 4 CO 5

5.2	Optical measuring instruments, basic principle – interferometer-optical flat –optical tool makers’ microscope-autocollimator.	2	CO 5
5.3	Comparators – mechanical, optical, pneumatic, electric and electronic comparators. (Self learning portion, discretion of faculty, fundamentals to be explained in the class).	1	CO 4
5.4	Measurements of surface roughness – elements of roughness – symbols specifying –instruments and for measuring surface roughness-	1	CO 4
	Measurements of screw: terminology, measurement of screw thread elements-measurement of gears: terminology, errors in spur gears, measurement of gear elements.	2	
5.5	Advanced measuring devices – Laser interferometers-Coordinate Measuring Machine (CMM)	1	CO 5

COURSE CODE	COURSE NAME	CATEGORY	L	T	P	CREDITS
22HUT505	INDUSTRIAL ECONOMICS AND FOREIGN TRADE	HU	3	0	0	3

Preamble: To equip the students to take industrial decisions and to create awareness of economic environment.

Prerequisite: Nil

Course Outcomes: After the completion of the course the student will be able to

CO1	Explain the problem of scarcity of resources and consumer behaviour, and to evaluate the impact of government policies on the general economic welfare. (Cognitive knowledge level: Understand)
CO2	Take appropriate decisions regarding volume of output and to evaluate the social cost of production. (Cognitive knowledge level: Apply)
CO3	Determine the functional requirement of a firm under various competitive conditions. (Cognitive knowledge level: Analyse)
CO4	Examine the overall performance of the economy, and the regulation of economic fluctuations and its impact on various sections in the society. (Cognitive knowledge level: Analyse)
CO5	Determine the impact of changes in global economic policies on the business opportunities of a firm. (Cognitive knowledge level: Analyse)

Mapping of course outcomes with program outcomes

	PO1	PO2	PO3	PO4	PO5	PO6	PO7	PO8	PO9	PO10	PO11	PO12
CO1	2										3	
CO2	2	2			2	2	3				3	
CO3	2	2	1								3	
CO4	2	2	1			1					3	
CO5	2	2	1								3	



Abstract POs defined by National Board of Accreditation			
PO#	Broad PO	PO#	Broad PO
PO1	Engineering Knowledge	PO7	Environment and Sustainability
PO2	Problem Analysis	PO8	Ethics
PO3	Design/Development of solutions	PO9	Individual and team work
PO4	Conduct investigations of complex problems	PO10	Communication
PO5	Modern tool usage	PO11	Project Management and Finance
PO6	The Engineer and Society	PO12	Lifelong learning

#### Assessment Pattern

Bloom's Category	Continuous Assessment Tests		End Semester Examination Marks
	Test 1 (Marks)	Test 2 (Marks)	
Remember	15	15	30
Understand	20	20	40
Apply	15	15	30

#### Mark Distribution

Total Marks	CIE Marks	ESE Marks	ESE Duration
150	50	100	3 hours

#### Continuous Internal Evaluation Pattern:

Attendance	: 10 marks
Continuous Assessment - Test (2 numbers)	: 25 marks
Continuous Assessment - Assignment	: 15 marks

#### Internal Examination Pattern:

Each of the two internal examinations has to be conducted out of 50 marks. First series test shall be preferably conducted after completing the first half of the syllabus and the second series test shall be preferably conducted after completing remaining part of the syllabus. There will be two parts: Part A and Part B. Part A contains 5 questions (preferably, 2 questions each from the completed modules and 1 question from the partly completed module), having 3 marks for each question adding up to 15 marks for part A. Students should answer all questions from Part A. Part B contains 7 questions (preferably, 3 questions each from the completed modules and 1 question from the partly completed module), each with 7 marks. Out of the 7 questions, a student should answer any 5.

#### End Semester Examination Pattern:

There will be two parts; Part A and Part B.

Part A : 30 marks

Part B : 70 marks

Part A contains 10 questions with 2 questions from each module, having 3 marks for each question. Students should answer all questions. Part B contains 2 questions from each module of which a student should answer any one. Each question can have maximum 3 sub-divisions and carries 14 marks.

## SYLLABUS

### HUT 300 Industrial Economics & Foreign Trade

#### Module 1 (Basic Concepts and Demand and Supply Analysis)

Scarcity and choice - Basic economic problems- PPC – Firms and its objectives – types of firms – Utility – Law of diminishing marginal utility – Demand and its determinants – law of demand – elasticity of demand – measurement of elasticity and its applications – Supply, law of supply and determinants of supply – Equilibrium – Changes in demand and supply and its effects – Consumer surplus and producer surplus (Concepts) – Taxation and deadweight loss.

#### Module 2 (Production and cost)

Production function – law of variable proportion – economies of scale – internal and external economies – Isoquants, isocost line and producer's equilibrium – Expansion path – Technical progress and its implications – Cobb-Douglas production function - Cost concepts – Social cost: private cost and external cost – Explicit and implicit cost – sunk cost - Short run cost curves - long run cost curves – Revenue (concepts) – Shutdown point – Break-even point.

#### Module 3 (Market Structure)

Perfect and imperfect competition – monopoly, regulation of monopoly, monopolistic completion (features and equilibrium of a firm) – oligopoly – Kinked demand curve – Collusive oligopoly (meaning) – Non-price competition – Product pricing – Cost plus pricing – Target return pricing – Penetration pricing – Predatory pricing – Going rate pricing – Price skimming.

#### Module 4 (Macroeconomic concepts)

Circular flow of economic activities – Stock and flow – Final goods and intermediate goods - Gross Domestic Product - National Income – Three sectors of an economy- Methods of measuring national income – Inflation- causes and effects – Measures to control inflation- Monetary and fiscal policies – Business financing- Bonds and shares -Money market and Capital market – Stock market – Demat account and Trading account - SENSEX and NIFTY.

#### Module 5 (International Trade)

Advantages and disadvantages of international trade - Absolute and Comparative advantage theory - Heckscher - Ohlin theory - Balance of payments – Components – Balance of Payments

deficit and devaluation – Trade policy – Free trade versus protection – Tariff and non-tariff barriers.

#### Reference Materials

1. Gregory N Mankiw, 'Principles of Micro Economics', Cengage Publications
2. Gregory N Mankiw, 'Principles of Macro Economics', Cengage Publications
3. Dwivedi D N, 'Macro Economics', Tata McGraw Hill, New Delhi.
4. Mithani D M, 'Managerial Economics', Himalaya Publishing House, Mumbai.
5. Francis Cherunilam, 'International Economics', McGraw Hill, New Delhi.

#### Sample Course Level Assessment Questions

##### Course Outcome 1 (CO1):

1. Why does the problem of choice arise?
2. What are the central problems?
3. How do we solve the basic economic problems?
4. What is the relation between price and demand?
5. Explain deadweight loss due to the imposition of a tax.

##### Course Outcome 2 (CO2):

1. What is shutdown point?
2. What do you mean by producer equilibrium?
3. Explain break-even point;
4. Suppose a chemical factory is functioning in a residential area. What are the external costs?

##### Course Outcome 3 (CO3):

1. Explain the equilibrium of a firm under monopolistic competition.
2. Why is a monopolist called price maker?
3. What are the methods of non-price competition under oligopoly?

4. What is collusive oligopoly?

Course Outcome 4 (CO4):

1. What is the significance of national income estimation?
2. How is GDP estimated?
3. What are the measures to control inflation?
4. How does inflation affect fixed income group and wage earners?

Course Outcome 5 (CO5):

1. What is devaluation?
2. Suppose a foreign country imposes a tariff on Indian goods. How does it affect India's exports?
3. What is free trade?
4. What are the arguments in favour of protection?

Model Question paper

QP CODE:

PAGES:3

Reg No: \_\_\_\_\_

Name : \_\_\_\_\_

B.TECH DEGREE EXAMINATION, MONTH & YEAR

Course Code: HUT 300

Course Name: Industrial Economics & Foreign Trade

Max.Marks:100

Duration: 3 Hours

PART A

Answer all Questions. Each question carries 3 Marks

1. Why does an economic problem arise?
2. What should be the percentage change in price of a product if the sale is to be increased by 50 percent and its price elasticity of demand is 2?
3. In the production function  $Q = 2L^{1/2}K^{1/2}$  if  $L=36$  how many units of capital are needed to produce 60 units of output?
4. Suppose in the short run  $AVC < P < AC$ . Will this firm produce or shut down? Give reason.
5. What is predatory pricing?
6. What do you mean by non- price competition under oligopoly?
7. What are the important economic activities under primary sector?
8. Distinguish between a bond and share?
9. What are the major components of balance of payments?

10. What is devaluation?

(10 x 3 = 30 marks)

### PART B

(Answer one full question from each module, each question carries 14 marks)

#### MODULE I

11. a) Prepare a utility schedule showing units of consumption, total utility and marginal utility, and explain the law of diminishing marginal utility. Point out any three limitations of the law.

b) How is elasticity of demand measured according to the percentage method? How is the measurement of elasticity of demand useful for the government?

Or

12. a) Explain the concepts consumer surplus and producer surplus.

b) Suppose the government imposes a tax on a commodity where the tax burden is met by the consumers. Draw a diagram and explain dead weight loss. Mark consumer surplus, producer surplus, tax revenue and dead weight loss in the diagram.

#### MODULE II

13. a) What are the advantages of large-scale production?

b) Explain Producer equilibrium with the help of isoquants and isocost line. What is expansion path?

Or

14. a) Explain break-even analysis with the help of a diagram.

b) Suppose the monthly fixed cost of a firm is Rs. 40000 and its monthly total variable cost is Rs. 60000.

i. If the monthly sales is Rs. 120000 estimate contribution and break-even sales.

ii. If the firm wants to get a monthly profit of Rs.40000, what should be the sales?

c) The total cost function of a firm is given as  $TC=100+50Q - 11Q^2+Q^3$ . Find marginal cost when output equals 5 units.

#### MODULE III

15. a) What are the features of monopolistic competition?

b) Explain the equilibrium of a firm earning supernormal profit under monopolistic competition.

Or

16.a) Make comparison between perfect competition and monopoly.

b) Explain price rigidity under oligopoly with the help of a kinked demand curve.

#### MODULE IV

17. a) How is national income estimated under product method and expenditure method?

b) Estimate GDPmp, GNPmp and National income

Private consumption expenditure	= 2000 (in 000 cores)
Government Consumption	= 500
NFIA	= -(300)
Investment	= 800
Net=exports	=700
Depreciation	= 400
Net-indirect tax	= 300

Or

18. a) What are the monetary and fiscal policy measures to control inflation?

b) What is SENSEX?

#### MODULE V

19. a) What are the advantages of disadvantages of foreign trade?

b) Explain the comparative cost advantage.

Or

20. a) What are the arguments in favour protection?

b) Examine the tariff and non-tariff barriers to international trade.

(5 × 14 = 70 marks)



### Teaching Plan

Module 1 (Basic concepts and Demand and Supply Analysis)		7 Hours
1.1	Scarcity and choice – Basic economic problems - PPC	1 Hour
1.2	Firms and its objectives – types of firms	1 Hour
1.3	Utility – Law of diminishing marginal utility – Demand – law of demand	1 Hour
1.4	Measurement of elasticity and its applications	1 Hour
1.5	Supply, law of supply and determinants of supply	1 Hour
1.6	Equilibrium – changes in demand and supply and its effects	1 Hour
1.7	Consumer surplus and producer surplus (Concepts) – Taxation and deadweight loss.	1 Hour
Module 2 (Production and cost)		7 Hours
2.1	Productions function – law of variable proportion	1 Hour
2.2	Economies of scale – internal and external economies	1 Hour
2.3	producers equilibrium – Expansion path	1 Hour
2.4	Technical progress and its implications – cob Douglas Production function	1 Hour
2.5	Cost concepts – social cost: private cost and external cost – Explicit and implicit cost – sunk cost	1 Hour
2.6	Short run cost curves & Long run cost curves	1 Hour
2.7	Revenue (concepts) – shutdown point – Break-even point.	1 Hour
Module 3 (Market Structure)		6 hours
3.1	Equilibrium of a firm, MC – MR approach and TC – TR approach	1 Hour
3.2	Perfect competition & Imperfect competition	1 Hour
3.3	Monopoly – Regulation of monopoly – Monopolistic competition	1 Hour
3.4	Oligopoly – kinked demand curve	1 Hour
3.5	Collusive oligopoly (meaning) – Non price competition	1 Hour
3.6	Cost plus pricing – Target return pricing – Penetration, Predatory pricing – Going rate pricing – price skimming	1 Hour

Module 4 (Macroeconomic concepts)		7 Hours
4.1	Circular flow of economic activities	1 Hour
4.2	Stock and flow – Final goods and intermediate goods – Gross Domestic Product - National income – Three sectors of an economy	1 Hour
4.3	Methods of measuring national income	1 Hour
4.4	Inflation – Demand pull and cost push – Causes and effects	1 Hour
4.5	Measures to control inflation – Monetary and fiscal policies	1 Hour
4.6	Business financing – Bonds and shares – Money market and capital market	1 Hour
4.7	Stock market – Demat account and Trading account – SENSEX and NIFTY	1 Hour
Module 5 (International Trade)		8 Hours
5.1	Advantages and disadvantages of international trade	1 Hour
5.2	Absolute and comparative advantage theory	2 Hour
5.3	Heckscher – Ohlin theory	1 Hour
5.4	Balance of payments - components	1 Hour
5.5	Balance of payments deficit and devaluation	1 Hour
5.6	Trade policy – Free trade versus protection	1 Hour
5.7	Tariff and non tariff barriers.	1 Hour

COURSE CODE	COURSE NAME	CATEGORY	L	T	P	CREDITS
22HUT506	MANAGEMENT FOR ENGINEERS	HU	3	0	0	3

Preamble: This course is intended to help the students to learn the basic concepts and functions of management and its role in the performance of an organization and to understand various decision-making approaches available for managers to achieve excellence. Learners shall have a broad view of different functional areas of management like operations, human resource, finance and marketing.

Prerequisite: Nil

Course Outcomes After the completion of the course the student will be able to

CO1	Explain the characteristics of management in the contemporary context (Cognitive Knowledge level: Understand).
CO2	Describe the functions of management (Cognitive Knowledge level: Understand).
CO3	Demonstrate ability in decision making process and productivity analysis (Cognitive Knowledge level: Understand).
CO4	Illustrate project management technique and develop a project schedule (Cognitive Knowledge level: Apply).
CO5	Summarize the functional areas of management (Cognitive Knowledge level: Understand).
CO6	Comprehend the concept of entrepreneurship and create business plans (Cognitive Knowledge level: Understand).

Mapping of course outcomes with program outcomes

	PO1	PO2	PO3	PO4	PO5	PO6	PO7	PO8	PO9	PO10	PO11	PO12
CO1	2				1	2	2	2		2	1	1
CO2	2				1	1		2	1	2	1	1
CO3	2	2	2	2	1							
CO4	2	2	2	2	1						2	1
CO5	2					1	1		1	2	1	
CO6		2	2	2	1	1	1	1	1	1	1	1

Abstract POs defined by National Board of Accreditation				
PO1	Engineering Knowledge		PO7	Environment and Sustainability
PO2	Problem Analysis		PO8	Ethics
PO3	Design/Development of solutions		PO9	Individual and team work
PO4	Conduct investigations of complex problems		PO10	Communication
PO5	Modern tool usage		PO11	Project Management and Finance
PO6	The Engineer and Society		PO12	Life long learning

Assessment Pattern

Bloom's Category	Test 1 (Marks in percentage)	Test 2 (Marks in percentage)	End Semester Examination (Marks in percentage)
Remember	15	15	30
Understand	15	15	30
Apply	20	20	40
Analyse			
Evaluate			
Create			

## Mark Distribution

Total Marks	CIE Marks	ESE Marks	ESE Duration
150	50	100	3 Hours

### Continuous Internal Evaluation Pattern:

Attendance : 10 marks

Continuous Assessment - Test : 25 marks

Continuous Assessment - Assignment : 15 marks

### Internal Examination Pattern:

Each of the two internal examinations has to be conducted out of 50 marks. First series test shall be preferably conducted after completing the first half of the syllabus and the second series test shall be preferably conducted after completing remaining part of the syllabus. There will be two parts: Part A and Part B. Part A contains 5 questions (preferably, 2 questions each from the completed modules and 1 question from the partly completed module), having 3 marks for each question adding up to 15 marks for part A. Students should answer all questions from Part A. Part B contains 7 questions (preferably, 3 questions each from the completed modules and 1 question from the partly completed module), each with 7 marks. Out of the 7 questions, a student should answer any 5.

### End Semester Examination Pattern:

There will be two parts; Part A and Part B. Part A contains 10 questions with 2 questions from each module, having 3 marks for each question. Students should answer all questions. Part B contains 2 questions from each module of which a student should answer any one. Each question can have maximum 2 sub-divisions and carries 14 marks.

## SYLLABUS

HUT 310 Management for Engineers (35 hrs)

### Module 1 (Introduction to management Theory- 7 Hours)

Introduction to management theory, Management Defined, Characteristic of Management, Management as an art-profession, System approaches to Management, Task and Responsibilities of a professional Manager, Levels of Manager and Skill required.

### Module 2 (management and organization- 5 hours)

Management Process, Planning types , Mission, Goals, Strategy, Programmes, Procedures, Organising, Principles of Organisation, Delegation, Span of Control, Organisation Structures, Directing, Leadership, Motivation, Controlling..

### Module 3 (productivity and decision making- 7 hours)

Concept of productivity and its measurement; Competitiveness; Decision making process; decision making under certainty, risk and uncertainty; Decision trees; Models of decision making.

### . Module 4 (project management- 8 hours)

Project Management, Network construction, Arrow diagram, Redundancy. CPM and PERT Networks, Scheduling computations, PERT time estimates, Probability of completion of project, Introduction to crashing.

### Module 5 (functional areas of management- 8 hours)

Introduction to functional areas of management, Operations management, Human resources management, Marketing management, Financial management, Entrepreneurship, Business plans, Corporate social responsibility, Patents and Intellectual property rights.

References:

1. H. Koontz, and H. Weihrich, Essentials of Management: An International Perspective. 8th ed., McGraw-Hill, 2009.
2. P C Tripathi and P N Reddy, Principles of management, TMH, 4<sup>th</sup> edition, 2008.
3. P. Kotler, K. L. Keller, A. Koshy, and M. Jha, Marketing Management: A South Asian Perspective. 14th ed., Pearson, 2012.
4. M. Y. Khan, and P. K. Jain, Financial Management, Tata-McGraw Hill, 2008.
5. R. D. Hisrich, and M. P. Peters, Entrepreneurship: Strategy, Developing, and Managing a New Enterprise, 4th ed., McGraw-Hill Education, 1997.
6. D. J. Sumanth, Productivity Engineering and Management, McGraw-Hill Education, 1985.
7. K.Ashwathappa, 'Human Resources and Personnel Management', TMH, 3<sup>rd</sup> edition, 2005.
8. R. B. Chase, Ravi Shankar and F. R. Jacobs, Operations and Supply Chain Management, 14th ed. McGraw Hill Education (India), 2015.

#### Sample Course Level Assessment Questions

Course Outcome1 (CO1): Explain the systems approach to management?

Course Outcome 2 (CO2): Explain the following terms with a suitable example Goal, Objective, and Strategy.

Course Outcome 3 (CO3): Mr. Shyam is the author of what promises to be a successful novel. He has the option to either publish the novel himself or through a publisher. The publisher is offering Mr. Shyam Rs. 20,000 for signing the contract. If the novel is successful, it will sell 200,000 copies. Else, it will sell 10,000 copies only. The publisher pays a Re. 1 royalty per copy. A market survey indicates that there is a 70% chance that the novel will be successful. If Mr. Shyam undertakes publishing, he will incur an initial cost of Rs. 90,000 for printing and marketing., but each copy sold will net him Rs. 2. Based on the given information and the

decision analysis method, determine whether Mr. Shyam should accept the publisher's offer or publish the novel himself.

Course Outcome 4 (CO4): Explain the concepts of crashing and dummy activity in project management.

Course Outcome 5 (CO5): Derive the expression for the Economic order quantity (EOQ)?

Course Outcome 6 (CO6): Briefly explain the theories of Entrepreneurial motivation.?



Model Question Paper

QP CODE:

PAGES: 4

Reg No: \_\_\_\_\_

Name: \_\_\_\_\_

APJ ABDUL KALAM TECHNOLOGICAL UNIVERSITY  
FOURTH SEMESTER B.TECH DEGREE EXAMINATION, MONTH & YEAR

Course Code: HUT 310

Course name: Management for Engineers

Max Marks: 100

Duration: 3 Hours

PART-A (Answer All Questions. Each question carries 3 marks)

1. "Management is getting things done through other." Elaborate.
2. Comment on the true nature of management. Is it a science or an art?
3. Planning is looking ahead and controlling is looking back. Comment with suitable examples
4. Explain the process of communication?
5. Explain the hierarchy of objectives?
6. Explain the types of decisions?
7. Describe the Economic man model?
8. Explain the concepts of crashing and dummy activity in project management.
9. Differentiate the quantitative and qualitative methods in forecasting.
10. What are the key metrics for sustainability measurement? What makes the measurement and reporting of sustainability challenging?

PART-B (Answer any one question from each module)

11. a) Explain the systems approach to management. (10)  
b) Describe the roles of a manager (4)

OR

12. a) Explain the 14 principles of administrative management? (10)

b) Explain the different managerial skills (4)

13. a) What are planning premises, explain the classification of planning premises. (10)

b) Distinguish between strategy and policy. How can policies be made effective. (4)

OR

14 a) Explain three motivational theories. (9)

b) Describe the managerial grid. (5)

15. a) Modern forest management uses controlled fires to reduce fire hazards and to stimulate new forest growth. Management has the option to postpone or plan a burning. In a specific forest tract, if burning is postponed, a general administrative cost of Rs. 300 is incurred. If a controlled burning is planned, there is a 50% chance that good weather will prevail and burning will cost Rs. 3200. The results of the burning may be either successful with probability 0.6 or marginal with probability 0.4. Successful execution will result in an estimated benefit of Rs. 6000, and marginal execution will provide only Rs. 3000 in benefits. If the weather is poor, burning will be cancelled incurring a cost of Rs. 1200 and no benefit. i) Develop a decision tree for the problem. (ii) Analyse the decision tree and determine the optimal course of action. (8)

b) Student tuition at ABC University is \$100 per semester credit hour. The Education department supplements the university revenue by matching student tuition, dollars per dollars. Average class size for typical three credit course is 50 students. Labour costs are \$4000 per class, material costs are \$20 per student, and overhead cost are \$25,000 per class. (a) Determine the total factor productivity. (b) If instructors deliver lecture 14 hours per week and the semester lasts for 16 weeks, what is the labour productivity? (6)

OR

16. a) An ice-cream retailer buys ice cream at a cost of Rs. 13 per cup and sells it for Rs. 20 per cup; any remaining unsold at the end of the day, can be disposed at a salvage price of Rs. 2.5 per cup. Past sales have ranged between 13 and 17 cups per day; there is no reason to believe that

sales volume will take on any other magnitude in future. Find the expected monetary value and EOL, if the sales history has the following probabilities:  
(9)

Market Size	13	14	15	16	17
Probability	0.10	0.15	0.15	0.25	0.35

b) At Modem Lumber Company, Kishore the president and a producer of an apple crates sold to growers, has been able, with his current equipment, to produce 240 crates per 100 logs. He currently purchases 100 logs per day, and each log required 3 labour hours to process. He believes that he can hire a professional buyer who can buy a better quality log at the same cost. If this is the case, he increases his production to 260 crates per 100 logs. His labour hours will increase by 8 hours per day. What will be the impact on productivity (measured in crates per labour-hour) if the buyer is hired? What is the growth in productivity in this case?  
(5)

17. a) A project has the following list of activities and time estimates:

Activity	Time (Days)	Immediate Predecessors
A	1	-
B	4	A
C	3	A
D	7	A
E	6	B
F	2	C, D
G	7	E, F
H	9	D
I	4	G, H

(a) Draw the network. (b) Show the early start and early finish times. (c) Show the critical path.  
(10)

b) An opinion survey involves designing and printing questionnaires, hiring and training personnel, selecting participants, mailing questionnaires and analysing data. Develop the precedence relationships and construct the project network. (4)

OR

18. a) The following table shows the precedence requirements, normal and crash times, and normal and crash costs for a construction project:

Activity	Immediate Predecessors	Required Time (Weeks)		Cost (Rs.)	
		Normal	Crash	Normal	Crash
A	-	4	2	10,000	11,000
B	A	3	2	6,000	9,000
C	A	2	1	4,000	6,000
D	B	5	3	14,000	18,000
E	B, C	1	1	9,000	9,000
F	C	3	2	7,000	8,000
G	E, F	4	2	13,000	25,000
H	D, E	4	1	11,000	18,000
I	H, G	6	5	20,000	29,000

Draw the network. (b) Determine the critical path. (c) Determine the optimal duration and the associated cost. (10)

b) Differentiate between CPM and PERT. (4)

19. a) What is meant by market segmentation and explain the process of market segmentation (8)

b) The Honda Co. in India has a division that manufactures two-wheel motorcycles. Its budgeted sales for Model G in 2019 are 80,00,000 units. Honda's target ending inventory is 10,00,000 units and its beginning inventory is 12,00,000 units. The company's budgeted selling price to its distributors and dealers is Rs. 40,000 per motorcycle. Honda procures all its wheels from an

outside supplier. No defective wheels are accepted. Honda's needs for extra wheels for replacement parts are ordered by a separate division of the company. The company's target ending inventory is 3,00,000 wheels and its beginning inventory is 2,00,000 wheels. The budgeted purchase price is Rs. 1,600 per wheel.

(a) Compute the budgeted revenue in rupees.

(b) Compute the number of motorcycles to be produced.

Compute the budgeted purchases of wheels in units and in rupees.? (6)

OR

20. a) a) "Human Resource Management policies and principles contribute to effectiveness, continuity and stability of the organization". Discuss. (b) What is a budget? Explain how sales budget and production budgets are prepared? (10)

b) Distinguish between the following: (a) Assets and Liabilities (b) Production concept and Marketing concept (c) Needs and Wants (d) Design functions and Operational control functions in operations (4)

## Teaching Plan

Sl.No	TOPIC	SESSION
	Module I	
1.1	Introduction to management	1
1.2	Levels of managers and skill required	2
1.3	Classical management theories	3
1.4	neo-classical management theories	4
1.5	modern management theories	5
1.6	System approaches to Management,	6
1.7	Task and Responsibilities of a professional Manager	7
	Module 2	
2.1	Management process – planning	8
2.2	Mission – objectives – goals – strategy – policies – programmes – procedures	9
2.3	Organizing, principles of organizing, organization structures	10
2.4	Directing, Leadership	11
2.5	Motivation, Controlling	12
	Module III	
3.1	Concept of productivity and its measurement Competitiveness	13
3.2	Decision making process;	14
3.3	Models in decision making	15
3.4	Decision making under certainty and risk	16
3.5	Decision making under uncertainty	17
3.6	Decision trees	18
3.7	Models of decision making.	19
	Module IV	
4.1	Project Management	20

Sl.No	TOPIC	SESSION
	Module I	
4.2	Network construction	21
4.3	Arrow diagram, Redundancy	22
4.4	CPM and PERT Networks	23
4.5	Scheduling computations	24
4.6	PERT time estimates	25
4.7	Probability of completion of project	26
4.8	Introduction to crashing	
	Module V	
5.1	Introduction to functional areas of management,	28
5.2	Operations management	29
5.3	Human resources management ,	30
5.4	Marketing management	31
5.5	Financial management	32
5.6	Entrepreneurship,	33
5.7	Business plans	34
5.8	Corporate social responsibility, Patents and Intellectual property rights	35

COURSE CODE	COURSE NAME	CATEGORY	L	T	P	CREDITS
22MNC507	DISASTER MANAGEMENT	MNC	2	0	0	--

Preamble: The objective of this course is to introduce the fundamental concepts of hazards and disaster management.

Prerequisite: Nil

Course Outcomes: After the completion of the course the student will be able to

CO1	Define and use various terminologies in use in disaster management parlance and organise each of these terms in relation to the disaster management cycle (Cognitive knowledge level: Understand).
CO2	Distinguish between different hazard types and vulnerability types and do vulnerability assessment (Cognitive knowledge level: Understand).
CO3	Identify the components and describe the process of risk assessment, and apply appropriate methodologies to assess risk (Cognitive knowledge level: Understand).
CO4	Explain the core elements and phases of Disaster Risk Management and develop possible measures to reduce disaster risks across sector and community (Cognitive knowledge level: Apply)
CO5	Identify factors that determine the nature of disaster response and discuss the various disaster response actions (Cognitive knowledge level: Understand).
CO6	Explain the various legislations and best practices for disaster management and risk reduction at national and international level (Cognitive knowledge level: Understand).



Mapping of course outcomes with program outcomes

	PO1	PO2	PO3	PO4	PO5	PO6	PO7	PO8	PO9	PO10	PO11	PO12
CO1		2				2				2		2
CO2	2	3	2		2	2	3			3		2
CO3	2	3	2	2	2	2	3			3		2
CO4	3	3	3		2	2	3					2
CO5	3	3			2	2	3					2
CO6	3					2	3	3				2

Abstract POs defined by National Board of Accreditation			
PO#	Broad PO	PO#	Broad PO
PO1	Engineering Knowledge	PO7	Environment and Sustainability
PO2	Problem Analysis	PO8	Ethics
PO3	Design/Development of solutions	PO9	Individual and team work
PO4	Conduct investigations of complex problems	PO10	Communication
PO5	Modern tool usage	PO11	Project Management and Finance
PO6	The Engineer and Society	PO12	Life long learning

### Assessment Pattern

Bloom's Category	Continuous Assessment Tests		End Semester Examination Marks
	Test 1 (Marks)	Test 2 (Marks)	
Remember	10	10	20
Understand	25	25	50
Apply	15	15	30
Analyze			
Evaluate			
Create			

### Mark Distribution

Total Marks	CIE Marks	ESE Marks	ESE Duration
150	50	100	3 hours

### Continuous Internal Evaluation Pattern:

Attendance : 10 marks

Continuous Assessment - Test : 25 marks

Continuous Assessment - Assignment : 15 marks

### Internal Examination Pattern:

Each of the two internal examinations has to be conducted out of 50 marks. First series test shall be preferably conducted after completing the first half of the syllabus and the second series test shall be preferably conducted after completing remaining part of the syllabus. There will be two parts: Part A and Part B. Part A contains 5 questions (preferably, 2 questions each from the completed modules and 1 question from the partly completed module), having 3 marks for each question adding up to 15 marks for part A. Students should answer all questions from Part A.

Part B contains 7 questions (preferably, 3 questions each from the completed modules and 1 question from the partly completed module), each with 7 marks. Out of the 7 questions, a student should answer any 5.

**End Semester Examination Pattern:**

There will be two parts; Part A and Part B. Part A contains 10 questions with 2 questions from each module, having 3 marks for each question. Students should answer all questions. Part B contains 2 questions from each module of which a student should answer any one. Each question can have maximum 2 sub-divisions and carries 14 marks.

## SYLLABUS

### MCN 301 Disaster Management

#### Module 1

##### Systems of earth

Lithosphere- composition, rocks, soils; Atmosphere-layers, ozone layer, greenhouse effect, weather, cyclones, atmospheric circulations, Indian Monsoon; hydrosphere- Oceans, inland water bodies; biosphere

Definition and meaning of key terms in Disaster Risk Reduction and Management- disaster, hazard, exposure, vulnerability, risk, risk assessment, risk mapping, capacity, resilience, disaster risk reduction, disaster risk management, early warning systems, disaster preparedness, disaster prevention, disaster mitigation, disaster response, damage assessment, crisis counselling, needs assessment.

#### Module 2

Hazard types and hazard mapping; Vulnerability types and their assessment- physical, social, economic and environmental vulnerability.

Disaster risk assessment –approaches, procedures

#### Module 3

Disaster risk management -Core elements and phases of Disaster Risk Management

Measures for Disaster Risk Reduction – prevention, mitigation, and preparedness.

Disaster response- objectives, requirements; response planning; types of responses.

Relief; international relief organizations.

#### Module 4

Participatory stakeholder engagement; Disaster communication- importance, methods, barriers; Crisis counselling

Capacity Building: Concept – Structural and Non-structural Measures, Capacity Assessment; Strengthening Capacity for Reducing Risk

## Module 5

Common disaster types in India; Legislations in India on disaster management; National disaster management policy; Institutional arrangements for disaster management in India.

The Sendai Framework for Disaster Risk Reduction- targets, priorities for action, guiding principles

### Reference Text Book

1. R. Subramanian, Disaster Management, Vikas Publishing House, 2018
2. M. M. Sulphrey, Disaster Management, PHI Learning, 2016
3. UNDP, Disaster Risk Management Training Manual, 2016
4. United Nations Office for Disaster Risk Reduction, Sendai Framework for Disaster Risk Reduction 2015-2030, 2015

### Sample Course Level Assessment Questions

#### Course Outcome 1 (CO1):

1. What is the mechanism by which stratospheric ozone protects earth from harmful UV rays?
2. What are disasters? What are their causes?
3. Explain the different types of cyclones and the mechanism of their formation
4. Explain with examples, the difference between hazard and risk in the context of disaster management
5. Explain the following terms in the context of disaster management (a) exposure (b) resilience (c) disaster risk management (d) early warning systems, (e) damage assessment (f) crisis counselling (g) needs assessment

#### Course Outcome 2 (CO2):

1. What is hazard mapping? What are its objectives?
2. What is participatory hazard mapping? How is it conducted? What are its advantages?
3. Explain the applications of hazard maps
4. Explain the types of vulnerabilities and the approaches to assess them

#### Course Outcome 3 (CO3):

1. Explain briefly the concept of 'disaster risk'

2. List the strategies for disaster risk management ‘before’, ‘during’ and ‘after’ a disaster
3. What is disaster preparedness? Explain the components of a comprehensive disaster preparedness strategy

Course Outcome 4 (CO4):

1. What is disaster prevention? Distinguish it from disaster mitigation giving examples
2. What are the steps to effective disaster communication? What are the barriers to communication?
3. Explain capacity building in the context of disaster management

Course Outcome 5 (CO5):

1. Briefly explain the levels of stakeholder participation in the context of disaster risk reduction
2. Explain the importance of communication in disaster management
3. Explain the benefits and costs of stakeholder participation in disaster management
4. How are stakeholders in disaster management identified?

Course Outcome 6 (CO6):

1. Explain the salient features of the National Policy on Disaster Management in India
2. Explain the guiding principles and priorities of action according to the Sendai Framework for Disaster Risk Reduction
3. What are Tsunamis? How are they caused?
4. Explain the earthquake zonation of India

Model Question paper

QP CODE:

PAGES:3

Reg No:\_\_\_\_\_

Name :\_\_\_\_\_

FIFTH SEMESTER B.TECH DEGREE EXAMINATION, MONTH & YEAR

Course Code: MCN 301

Course Name: Disaster Management

Max.Marks:100

Duration: 3 Hours

PART A

Answer all Questions. Each question carries 3 Marks

1. What is the mechanism by which stratospheric ozone protects earth from harmful UV rays?
2. What are disasters? What are their causes?
3. What is hazard mapping? What are its objectives?
4. Explain briefly the concept of 'disaster risk'
5. List the strategies for disaster risk management 'before', 'during' and 'after' a disaster
6. What is disaster prevention? Distinguish it from disaster mitigation giving examples
7. Briefly explain the levels of stakeholder participation in the context of disaster risk reduction
8. Explain the importance of communication in disaster management
9. What are Tsunamis? How are they caused?
10. Explain the earthquake zonation of India

Part B

Answer any one Question from each module. Each question carries 14 Marks

11. a. Explain the different types of cyclones and the mechanism of their formation [10]  
b. Explain with examples, the difference between hazard and risk in the context of disaster management [4]

OR

12. Explain the following terms in the context of disaster management [14]  
(a) exposure (b) resilience (c) disaster risk management (d) early warning systems, (e) damage assessment (f) crisis counselling (g) needs assessment

13. a. What is participatory hazard mapping? How is it conducted? What are its advantages? [8]  
b. Explain the applications of hazard maps [6]

OR

14. Explain the types of vulnerabilities and the approaches to assess them [14]  
15. a. Explain the core elements of disaster risk management [8]  
b. Explain the factors that decide the nature of disaster response [6]

OR

16. a. What is disaster preparedness? Explain the components of a comprehensive disaster preparedness strategy [6]  
b. Explain the different disaster response actions [8]  
17. a. Explain the benefits and costs of stakeholder participation in disaster management [10]  
b. How are stakeholders in disaster management identified? [4]

OR

18. a. What are the steps to effective disaster communication? What are the barriers to communication? [7]  
b. Explain capacity building in the context of disaster management [7]



19. Explain the salient features of the National Policy on Disaster Management in India

[14]

OR

20. Explain the guiding principles and priorities of action according to the Sendai Framework for Disaster Risk Reduction

[14]

## Teaching Plan

Module 1		5 Hours
1.1	Introduction about various Systems of earth, Lithosphere-composition, rocks, Soils; Atmosphere-layers, ozone layer, greenhouse effect, weather	1 Hour
1.2	Cyclones, atmospheric circulations, Indian Monsoon; hydrosphere-Oceans, inland water bodies; biosphere	1 Hour
1.3	Definition and meaning of key terms in Disaster Risk Reduction and Management- disaster, hazard,	1 Hour
1.4	Exposure, vulnerability, risk, risk assessment, risk mapping, capacity, resilience, disaster risk reduction, Disaster risk management, early warning systems	1 Hour
1.5	Disaster preparedness, disaster prevention, disaster, Mitigation, disaster response, damage assessment, crisis counselling, needs assessment.	1 Hour
Module 2		5 Hours
2.1	Various Hazard types, Hazard mapping; Different types of Vulnerability types and their assessment	1 Hour
2.2	Vulnerability assessment and types, Physical and social vulnerability	1 Hour
2.3	Economic and environmental vulnerability, Core elements of disaster risk assessment	1 Hour
2.4	Components of a comprehensive disaster preparedness strategy approaches, procedures	1 Hour
2.5	Different disaster response actions	1 Hour
Module 3		5 Hours
3.1	Introduction to Disaster risk management, Core elements of Disaster Risk Management	1 Hour
3.2	Phases of Disaster Risk Management, Measures for Disaster Risk Reduction	1 Hour
3.3	Measures for Disaster prevention, mitigation, and preparedness.	1 Hour

3.4	Disaster response- objectives, requirements. Disaster response planning; types of responses.	1 Hour
3.5	Introduction- Disaster Relief, Relief; international relief organizations.	1 Hour
	Module 4	5 Hours
4.1	Participatory stakeholder engagement	1 Hour
4.2	Importance of disaster communication.	1 Hour
4.3	Disaster communication- methods, barriers. Crisis counselling	1 Hour
4.4	Introduction to Capacity Building. Concept – Structural Measures, Non-structural Measures.	1 Hour
4.5	Introduction to Capacity Assessment, Capacity Assessment; Strengthening, Capacity for Reducing Risk	1 Hour
	Module 5	5 Hours
5.1	Introduction-Common disaster types in India.	1 Hour
5.2	Common disaster legislations in India on disaster management	1 Hour
5.3	National disaster management policy, Institutional arrangements for disaster management in India.	1 Hour
5.4	The Sendai Framework for Disaster Risk Reduction and targets	1 Hour
5.5	The Sendai Framework for Disaster Risk Reduction-priorities for action, guiding principles	1 Hour

COURSE CODE	COURSE NAME	CATEGORY	L	T	P	CREDITS
22MEL508	MACHINE TOOLS LAB II	ES	0	0	3	2

Preamble:

1. To learn the measurement of bores by internal micrometers, bore indicators, indirect methods etc.
2. To learn the measurement of the Angle and taper by Bevel protractor, Sine bars, indirect methods etc.
3. Allow to study the various limits, fits and tolerances adopted in the production drawings.
4. To learn to measure straightness, flatness, roundness, profile, screw threads and gear teeth.
5. To learn, to prepare programs for CNC machines and measurements in CMM.

Course Outcomes - At the end of the course students will be able to

CO 1

Apply the procedures to measure length, angles, width, depth, bore diameters, internal and external tapers, tool angles, and surface roughness by using different instruments and by different indirect methods.

CO 2

Determine limits and fits and allocate tolerances for machine components

CO 3

CNC programming and to use coordinate measuring machine to record measurements of complex profiles with high sensitivity.

CO 4

Use effective methods of measuring straightness, Squareness, flatness, roundness, profile, screw threads and gear teeth.

CO 5

Securing knowledge of manufacturing components within the tolerance limit and surface roughness according to given drawings using various machine tools.

Mapping of course outcomes with program outcomes (Minimum requirements)

	PO 1	PO 2	PO 3	PO 4	PO 5	PO 6	PO 7	PO 8	PO 9	PO 10	PO 11	PO 12
CO 1	3	-	-	-	-	-	-	-	-	-	-	-
CO 2	-	-	3	-	-	-	-	-	-	-	-	-
CO 3	-	-		3	-	-	-	-	-	-	-	-
CO 4	-	3	-	-	-	-	-	-	-	-	-	-
CO 5	-	-	-	-	3	-	-	-	-	-	-	-

## Assessment Pattern

### Mark distribution

Total Marks	CIE	ESE	ESE Duration
150	75	75	2.5 hours

### Continuous Internal Evaluation Pattern:

Attendance	:	15 marks
Continuous Assessment	:	30 marks
Internal Test (Immediately before the second series test)	:	30 marks

End Semester Examination Pattern: The following guidelines should be followed regarding award of marks

(a) Preliminary work	:	15 Marks
(b) Implementing the work/Conducting the experiment	:	10 Marks
(c) Performance, result and inference (usage of equipments and trouble shooting)	:	25 Marks
(d) Viva voce	:	20 marks
(e) Record	:	5 Marks

### General instructions:

Practical examination is to be conducted immediately after the second series test covering entire syllabus given below. Evaluation is a serious process that is to be conducted under the equal responsibility of both the internal and external examiners. The number of candidates evaluated per day should not exceed 20. Students shall be allowed for the University examination only on submitting the duly certified record. The external examiner shall endorse the record.

## SYLLABUS

Experiments on Grinding machine – Programming and experiments on CNC machines-  
Uncertainty in metrology and measurement standards - Errors and their impact on the calculation of uncertainties - Measurement types and instrument selection - Geometric features of parts -  
Measuring straightness, squareness, flatness, roundness, and profile -Screw threads and gear teeth, optical contour projectors - Gage measurement - Surface texture and roughness measurement – flaw detection - Coordinate measuring machine - Modern measuring instruments and machines.

### Reference books

1. Yoram Koren, Numerical Control of Machine Tools, McGraw-Hill.
2. Shotbolt C.R. and Gayler J.F.W, Metrology for Engineers, 5<sup>th</sup> edition, ELBS, London.
3. Sharp K.W.B. and Hume, Practical Engineering Metrology, Sir Isaac Pitman and sons Ltd,

London.

4. Collett, C.V. and Hope, A.D, Engineering Measurements, Second edition, ELBS/Longman

Experiments	List of Experiments	Course outcomes	No. of hours
1	Programming and experiment on CNC machines Study and preparation of programme, simulation and exercise on CNC lathe:-turning, step turning, taper turning, thread cutting, ball and cup turning etc.	CO 3	3
2	Study and preparation of programme, simulation and exercise on CNC milling machine: - surface milling, pocket milling, contour milling etc.		3
3	Experiment on Grinding machine Exercise on surface grinding, cylindrical grinding and tool grinding etc.	CO 1 CO 5	3
	Measurement of cutting forces and roughness in grinding process and correlate with varying input parameters.		
4	Basics for mechanical measurements Calibration of vernier caliper, micrometer and dial gauge. Determination of dimensions of given specimen using vernier caliper, micrometer, height gauge, bore dial gauge etc.	CO 1 CO 2	3
	Experiments on Limits, Fits and Tolerance Determine the class of fits between given shaft and hole. etc		
5	Experiments on Repeatability and Reproducibility Study and analysis of repeatability and reproducibility of given batch of steel balls. etc.	CO 1 CO 2	3
6	Linear measurements Study of different linear measuring instruments etc. Calibration of LVDT using slip gauges	CO 1 CO 5	3

7	<p><b>Straightness error measurement</b></p> <p>Study of different straightness error measuring instruments – basic principle of auto collimator, spirit level and laser interferometer.</p> <p>Measurement of straightness error of a CI surface plate using auto collimator and comparing with spirit level.</p> <p>Laser interferometer used to determine straightness error</p> <p>To check straightness error of a straight edge by the wedge method using slip gauges.</p>	CO 4	3
8	<p><b>Angle measurements</b></p> <p>Angular measurements using bevel protractor, combination sets, clinometers, angle dekkor etc.</p> <p>Measurement of angle and width of a V-block and comparing with combination sets.</p> <p>Measurement of angle using sine bar of different samples.</p> <p>Determination of angle and taper of a taper plug gauge</p>	CO 1	3
9	<p><b>Out of roundness measurement</b></p> <p>Study of different methods used for measuring out of roundness</p> <p>Measurement of out of roundness using form measuring instrument</p> <p>Measurement of out of roundness using V-block and dial gauge</p> <p>Measurement of out of roundness using bench centre and dial gauge etc.</p>	CO 4	3
10	<p><b>Screw thread measurement</b></p> <p>Measurement of screw thread parameters using two wire and three wire method.</p> <p>Measurement of screw thread parameters using tool maker's microscope etc.</p> <p>Measurement of screw thread parameters using thread ring gage, thread plug gage, thread snap gage, screw thread micrometer, optical comparator etc.</p>	CO 4	3
11	<p><b>Bore measurement</b></p> <p>Measurement of a bore by two ball method.</p> <p>Measurement of a bore by four ball method.</p> <p>Bore measurement using slip gauges and rollers.</p>	CO 1	3

	Bore measurement using bore dial gauge etc.		
12	<p>Gear metrology</p> <p>Study of types of gears – gear terminology – gear errors - Profile Projector.</p> <p>Measurement of profile error and gear parameters using profile projector etc.</p> <p>Use of Comparators</p> <p>Exercise on comparators: mechanical, optical, pneumatic and electronic comparators.</p>	CO 4	3
13	<p>Use of Tool maker’s microscope</p> <p>Study of tool maker’s microscope – use at shop floor applications.</p> <p>Measurement of gear tooth parameters using tool maker’s microscope.</p> <p>Measurement of different angles of single point cutting tool using tool maker’s microscope.</p>	CO 1	3
14	<p>Surface roughness measurement</p> <p>Measurement of surface roughness using surface profilometer /roughness measuring machine of turned, milled, grounded, lapped and glass etc specimens.</p>	CO 1	3
15	<p>Squareness measurement</p> <p>Determination of squareness of a trisquare using angle plate and slip gauges etc.</p>	CO 1	3
16	<p>Flatness measurement</p> <p>Study of optical flat and variation of fringe patterns for different surfaces.</p> <p>Determination of parallelism error between micrometer faces etc.</p> <p>Compare given surface using optical flat with interpretation chart.</p>	CO 4	3
17	<p>Vibration measurement</p> <p>Measurement of displacement, velocity and acceleration of vibration.</p>	CO 5	3



18	Use of Pneumatic comparator Checking the limits of dimensional tolerances using pneumatic comparator Calibration using air plug gauge etc	CO 5	3
19	Rotation measurement Determination of rpm using tachometer, optical tachometer and stroboscope, etc. Flaw detection Study and use of ultrasonic flaw detector.	CO 5	3
20	Other measurements Study and making measurements with precision vernier calipers, dial calipers, point micrometer spline micrometer, wire groove micrometer, depth micrometer, V- anvil micrometers, depth gear tooth micrometer, thread micrometer, disc micrometer, thread pitch gauge, vernier height gauge, feeler gauge, three pin micrometer, depth gauge, pitch gauge, thickness gauge, radius gauge, hole test etc. Analysis of automobile exhaust gas and flue gas. Use of feeler gauge to determine the gap of spark plug. Any other modern measuring instruments CMM, EDM, Wire cut EDM, USM etc	CO 5	3

A minimum of 12 sets of experiments are mandatory out of total 20 experiments but both experiments mentioned for programming and experiments on CNC machines are mandatory.

Besides to the skill development in performing the work, oral examination should be conducted during end semester examination.

The student's assessment, continuous evaluation, record bonafides, awarding of sessional marks, oral examination etc. should be carried out by the assistant professor or above.

COURSE CODE	COURSE NAME	CATEGORY	L	T	P	CREDITS
22MEL509	THERMAL ENGINEERING LAB I	ES	0	0	3	2

Preamble: The course is intended to impart basic understanding on the working of internal combustion engines. This includes various performance tests on internal combustion engines as well as makes the students familiar with the evaluation of fuel properties such as viscosity, flash and fire points, calorific value etc. which are key to any performance test.

Prerequisite: Should have undergone a course on Thermal Engineering with emphasis on IC engines

Course Outcomes: After completion of the course the student will be able to

CO 1	Measure thermo-physical properties of solid, liquid and gaseous fuels
CO 2	Identify various systems and subsystems of Diesel and petrol engines
CO 3	Analyse the performance characteristics of internal combustion engines
CO 4	Investigate the emission characteristics of exhaust gases from IC Engines
CO 5	Interpret the performance characteristics of air compressors / blowers

Mapping of course outcomes with program outcomes

	PO 1	PO 2	PO 3	PO 4	PO 5	PO 6	PO 7	PO 8	PO 9	PO 10	PO 11	PO 12
CO 1	3		2	3			2		3	2		2
CO 2	3		2	3			2		3	2		2
CO 3	3		2	3			2		3	2		2
CO 4	3		2	3			2		3	2		2
CO 5	3		2	3			2		3	2		2

Assessment Pattern

Mark distribution

Total Marks	CIE	ESE	ESE Duration
150	75	75	2.5 hours

Continuous Internal Evaluation Pattern:

Attendance	:	15 marks
Continuous Assessment	:	30 marks
Internal Test (Immediately before the second series test)	:	30 marks

End Semester Examination Pattern: The following guidelines should be followed regarding award of marks

- |  |            |
|--|------------|
| (a) Preliminary work   | : 15 Marks |
| (b) Implementing the work/Conducting the experiment                              | : 10 Marks |
| (c) Performance, result and inference (usage of equipments and trouble shooting) | : 25 Marks |
| (d) Viva voce  | : 20 marks |
| (e) Record   | : 5 Marks  |

General instructions:

Practical examination is to be conducted immediately after the second series test covering entire syllabus given below. Evaluation is a serious process that is to be conducted under the equal responsibility of both the internal and external examiners. The number of candidates evaluated per day should not exceed 20. Students shall be allowed for the University examination only on submitting the duly certified record. The external examiner shall endorse the record.

List of Exercises/Experiments: (Lab experiments may be given considering 12 sessions of 3 hours each. Minimum 12 experiments to be performed.)

1. Determination of flash and fire points of petroleum fuels and oils
2. Determination of viscosity of lubricating oils and fuels and its variation with temperature
3. Determination of calorific value of solid and liquid fuels- Bomb Calorimeter
4. Determination of calorific value of gaseous fuels –Gas Calorimeter
5. Familiarisation of various systems and subsystems of petrol engine / MPFI engine
6. Familiarisation of various systems and parts of Diesel engine / Turbocharged engine
7. Performance test on petrol engines / MPFI engine
8. Performance test on Diesel engines / Turbocharged engine
9. Heat Balance test on petrol/Diesel engines
10. Determination volumetric efficiency and Air-fuel ratio of IC engines
11. Cooling curve of IC engines
12. Valve timing diagram of IC engines
13. Economic speed test on IC engines
14. Retardation test on IC engines
15. Morse test on petrol engine
16. Experiment to find flame temperature of premixed flames at different equivalence ratios and temperature of diffusion flames at different fuel flow rates.
17. Analysis of automobile exhaust gas and flue gas using exhaust gas analyser.
18. Performance test on reciprocating compressor
19. Performance test on rotary compressor/blower

## Reference Books

1. J.B.Heywood, I.C engine fundamentals, McGraw-Hill, 2017
2. V. Ganesan, Fundamentals of IC engines, Tata McGraw-Hill, 2017
3. Stephen R Turns, An Introduction to Combustion: Concepts and Applications, McGraw-Hill, 2017

---

SEMESTER V

---

MINOR

---

COURSE CODE	COURSE NAME	CATEGORY	L	T	P	CREDITS
22MEMR509.1	DYNAMICS OF MACHINES	MR	3	1	0	4

Preamble: This course mainly covers the topics namely force analysis of engines, turning moment diagrams, balancing of rotating and reciprocating machines and stability analysis of vehicles. Analysis of free and forced vibration of single degree of freedom systems are included.

Prerequisite: EST100 Engineering Mechanics

Course Outcomes: After the completion of the course the student will be able to:

CO 1	Analyse forces in a four bar mechanism
CO 2	Draw turning moment diagrams for a steam engines and internal combustion engines.
CO 3	Calculate the unbalanced masses in rotating and reciprocating machines.
CO 4	Calculate gyroscopic couple and do stability analysis of vehicles
CO 5	Analyse free and forced vibrations of single degree of freedom systems

Mapping of course outcomes with program outcomes

	PO 1	PO 2	PO 3	PO 4	PO 5	PO 6	PO 7	PO 8	PO 9	PO 10	PO 11	PO 12
CO 1	3	3	2									
CO 2	3	3	2									
CO 3	3	3	2									
CO 4	3	3	2									
CO 5	3	3	2									

Assessment Pattern

Bloom's Category	Continuous Assessment Tests		End Semester Examination
	1	2	
Remember	10	10	10
Understand	20	20	20
Apply	20	20	70
Analyse			
Evaluate			
Create			

Mark distribution

Total Marks	CIE	ESE	ESE Duration
150	50	100	3 hours

### Continuous Internal Evaluation Pattern:

Attendance	: 10 marks
Continuous Assessment Test (2 numbers)	: 25 marks
Assignment/Quiz/Course project	: 15 marks

End Semester Examination Pattern: There will be two parts; Part A and Part B. Part A contain 10 questions with 2 questions from each module, having 3 marks for each question. Students should answer all questions. Part B contains 2 questions from each module of which student should answer any one. Each question can have maximum 2 sub-divisions and carry 14 marks.

### Course Level Assessment Questions

#### Course Outcome 1 (CO1):

1. Explain D' Alembert's principle.
2. Determine analytically the forces such as piston effort, force in the connecting rod and side thrust on the cylinder walls of a reciprocating engine.
3. Draw the force polygon of a four bar mechanism.
4. Use virtual work and determine the external torque required to be applied in the case of a slider-crank engine.

#### Course Outcome 2 (CO2)

1. Define coefficient of fluctuation of energy
2. Draw turning moment diagrams for single cylinder double stroke steam engine.
3. Find the centrifugal stress in a flywheel for a given tangential speed.
4. Determine the maximum fluctuation of energy for a multi cylinder engine.

#### Course Outcome 3 (CO3)

1. Distinguish between static balancing and dynamic balancing.
2. What is single plane balancing? Explain.
3. Draw the force polygon and couple polygon when several masses rotate in different (parallel) planes.
4. Explain i) hammer blow ii) variation in tractive effort and iii) swaying couple in locomotives
5. What do you mean by primary and secondary unbalanced forces?

#### Course Outcome 4 (CO4):

1. Derive an expression relating the stress in a flywheel and its linear speed.
2. Describe with neat sketches the effects of gyroscopic couple on pitching, rolling and steering of a ship
3. Find an expression for the angle of heel for a two wheeler

4. Define coefficient of fluctuation of energy and maximum fluctuation of energy.

Course Outcome 5 (CO5):

1. Explain the energy method and Newton's method to determine the natural frequencies of a single degree of freedom system.
2. Derive an expression for the logarithmic decrement.
3. Find the forced response of a damped single degree of freedom vibrating system subjected to a harmonic excitation.
4. Distinguish between motion transmissibility and force transmissibility.
5. What is whirling? Derive an expression for the critical speed of a shaft.



MODEL QUESTION PAPER

V SEMESTER BTECH DEGREE EXAMINATION

MET381: DYNAMICS OF MACHINES

Maximum: 100 Marks

Duration: 3 hours

PART A

Answer all questions, each question carries 3 marks

1. Explain virtual work method of force analysis of a four-bar mechanism.
2. What is meant by equivalent dynamic systems?
3. Define coefficient of fluctuation of energy and coefficient of fluctuation of speed.
4. Why flywheels are required?
5. Distinguish between static and dynamic balancing.
6. What is meant by partial balancing? List the effects of partial balancing.
7. Describe the effect of gyroscopic couple on the stability of a two-wheeler while negotiating a curve.
8. Define coefficient of fluctuation of speed and coefficient of fluctuation of energy.
9. Explain the energy method of obtaining the natural frequency of a single degree of freedom vibrating system.
10. Explain transmissibility. (10×3=30Marks)

PART B

Answer one full question from each module

MODULE 1

11. a) A slider crank mechanism of crank radius 60 mm and connecting rod length 240 mm is acted upon by 2 kN gas force at its piston. Calculate the torque to be applied on the crank to make the mechanism in static equilibrium when the crank makes 60° with the line of stroke. Use graphical method. (9 marks)  
b) Distinguish between static and dynamic force analyses. (5 marks)
12. a) State and explain D' Alembert's principle. (4 marks)

b) The ratio of connecting rod length to crank length of a vertical gasoline engine is 4. The engine bore and stroke are 8 cm and 10 cm respectively. The mass of the reciprocating parts is 1 kg. The gas pressure on the piston is 6 bar, when it has moved  $40^\circ$  from the inner dead centre during the power stroke. Determine:

- i. net load on the piston
- ii. net load on the gudgeon pin and the crank pin
- iii. thrust on the cylinder walls
- iv. thrust on the crank bearing

## MODULE 2

13. a) Derive an expression for the centrifugal stress in a flywheel as a function of the tangential velocity. (5 marks)

b) A machine is coupled to a two stroke engine which produces a torque of  $800 + 180 \sin 3\theta$  Nm where  $\theta$  is the crank angle. The mean engine speed is 400 rpm. The flywheel and the other rotating parts attached to the engine have a mass of 350 kg at a radius of gyration of 220 mm. Calculate: i) the power of the engine and ii) the total fluctuation of speed of the flywheel. (9 marks)

14.. a) Draw the turning moment diagram for a 4 stroke diesel engine. (4 marks)

b) The turning moment diagram for a multi cylinder engine has been draw to a scale of 1 cm to 5000 Nm torque and 1 cm to  $60^\circ$  respectively. The intercepted areas between output torque curve and mean resistance line taken in order from one end are: -0.3; +4.1; -2.8; +3.2; -3.3; +2.5; -3.6; +2.8; -2.6 square cm when the engine is running at 800 rpm. The engine has a stroke of 30 cm and the fluctuation of speed is not to exceed 2% of the mean speed. Determine a suitable diameter and cross-section of the flywheel rim for a limiting value of shaft centrifugal stress of  $280 \times 10^5$  N/m<sup>2</sup>. The material density may be assumed as 7.2 g/cm<sup>3</sup>. Assume thickness of the rim to be  $\frac{1}{4}$  of the width.

(10 marks)

## MODULE 3

15. a) Four masses 200 kg, 300 kg, 240 kg and 260 kg with radii of rotation are positioned at 20 cm, 15 cm, 25 cm and 30 cm respectively. Their corresponding angular positions with respect to mass 200 kg are  $45^\circ$ ,  $75^\circ$  and  $135^\circ$ . Find the

magnitude and position of the balancing mass required if the radius of rotation is 20 cm. (10 marks)

b) Dynamically balanced system is statically balanced, but not vice versa. Give your comments. (4 marks)

16. a) Describe the effects of partial balancing of reciprocating engines. (9 marks)

b) Four masses are attached to shaft at planes A, B, C and D at equal radii. The distance of planes B, C and D from A are 50 cm, 60 cm and 130 cm respectively. The masses at A, B and C are 60 kg, 55 kg and 80 kg respectively. If the system is in complete balance, determine the mass at D and the position of masses B, C and D with respect to A.

(10 marks)

#### MODULE 4

17. a) Explain spin vector, precession vector, gyroscopic applied torque vector and gyroscopic reactive torque vector. (4 marks)

b) Explain the effects of gyroscopic couple on the stability of a four wheeler while it negotiates a curve. (10 marks)

18. a) What is the function of a flywheel? (4 marks)

b) Determine the maximum and minimum speeds of a flywheel of mass 25 kg and radius of gyration of 10 cm when the fluctuation of energy is 54.5 Nm. The mean speed of the engine is 1000 rpm. (10 marks)

#### MODULE 5

19. a) A machine of mass 1000 kg is acted upon by an external force of 2450 N at a speed of 1500 rpm. To reduce the effect, vibration isolators made of rubber having a static deflection of 2 mm under the machine load and an estimated damping factor of 0.2 are used. Determine the following:

- i. Force transmitted to the foundation
- ii. Amplitude of vibration of machine
- iii. Phase lag between the transmitted force and the displacement of mass.

(10 marks)

b) Distinguish between motion transmissibility and displacement transmissibility.

(5 marks)

20.a) ) A damped spring mass system has mass 3 kg, stiffness 100 N/m and damping coefficient 3 Ns/m. Determine the following:

i. Damping ratio

ii. Damped natural frequency

iii. Logarithmic decrement

iv. Ratio of two successive amplitudes (8 marks)

b) Describe briefly Newton's method and energy method used for obtaining the natural frequencies. (6 marks)

## Syllabus

### Module 1

Static and dynamic force analysis of mechanisms (four bar linkages only)-graphical method-virtual work method -D'Alembert's principle-equivalent dynamic systems-reciprocating engine force analysis

### Module 2

Flywheels-turning moment diagrams for steam engines-four stroke internal combustion engine and multi cylinder engines-coefficient of fluctuation of speed-coefficient of fluctuation of energy-design of flywheels.

### Module 3

Balancing: static balancing-dynamic balancing-balancing of several masses revolving in a single plane-several masses in different parallel planes-balancing of single cylinder reciprocating engines-partial balancing and its effects-balancing of multi cylinder inline engines

### Module 4

Gyroscopic couple-effects on the stability of automobiles-two wheeler and four wheeler, stability of ships and air crafts-Flywheels-turning moment diagrams-coefficient of fluctuation of energy, coefficient of fluctuation of speed

### Module 5

Vibration-free vibration of single degree of freedom systems-equation of motion-Newton's method-energy method-natural frequency-undamped and damped systems-logarithmic decrement-forced vibration-response of SDOF systems to harmonic excitation-whirling of shaft-vibration absorber-transmissibility

### Text Books

1. Ballaney, P. L. Theory of machines and mechanisms. Khanna Publishers, 2010.
2. Rattan S S, Theory of Machines, Tata McGraw-Hill Education, 2005.

### Reference Books

1. Charles E Wilson and J Peter Sadler, Kinematics and Dynamics of Machinery, Tata McGraw-Hill Education, 2008.
2. Amithabha Ghosh and Asok Kumar Malik, Theory of Mechanisms and Machines, East West Press, 2011
3. Thomas Bevan, Theory of Machines, Pearson, 2013.

## Course Contents and Lecture Schedule

No	Topic	No. of Lectures
1		
1.1	Static analysis of mechanisms-graphical method-four bar mechanisms	3
1.2	Virtual work method -D'Alembert's principle-equivalent dynamic systems	3
1.3	Reciprocating engine force analysis	2
2		
2.1	Flywheels, turning moment diagrams-steam engines-four stroke internal combustion engines and multi cylinder engines	4
2.2	Multi cylinder engine-coefficient of fluctuation of speed-coefficient of fluctuation of energy-design of flywheels	4
3		
3.1	Static and dynamic balancing- balancing of several masses in a single plane-force polygon	3
3.2	Balancing of several masses in parallel planes-couple polygon	3
3.3	Balancing of reciprocating masses-effects of partial balancing	2
3.4	Balancing of multi cylinder in-line engines	2
4		
4.1	Gyroscopic couple-introduction-spin, precession and applied couple vectors	2
4.2	Effects of gyroscopic couple on the stability of two wheeler and four wheeler	2
4.3	Effects on the stability of sea vessels and air crafts	3
4.4	Flywheels-turning moment diagrams-coefficient of fluctuation of energy, coefficient of fluctuation of speed	3
5		
5.1	Vibration-free vibration of single degree of freedom systems-equation of motion-Newton's method-energy method-natural frequency	3
5.2	Damped systems-logarithmic decrement-forced vibration-response of SDOF systems to harmonic excitation	3
5.3	Whirling of shaft-vibration absorber- transmissibility	3

COURSE CODE	COURSE NAME	CATEGORY	L	T	P	CREDITS
22MEMR509.2	THERMAL SCIENCE AND ENGINEERING	MR	3	1	0	4

Preamble: This course involve the application of principles studied in thermodynamics to different energy conversion systems like steam turbine, steam powerplant, IC engines and refrigeration systems. This course also covers the methods for improving and evaluating the performance of different energy conversion systems. This course also helps to understand the combustion phenomenon in IC engines.

Prerequisite: MET284 Thermodynamics ( Minor)

Course Outcomes: After the completion of the course the student will be able to

CO 1	Explain the working of steam power cycle and related components
CO 2	Discuss the working of steam turbines and methods for evaluating the performance
CO 3	Illustrate the performance testing and evaluation of IC engines
CO 4	Explain the combustion phenomenon and pollution in IC engines
CO 5	Discuss the principles of refrigeration and air-conditioning and basic design considerations

Mapping of course outcomes with program outcomes

	PO 1	PO 2	PO 3	PO 4	PO 5	PO 6	PO 7	PO 8	PO 9	PO 10	PO 11	PO 12
CO 1	3	3	2									
CO 2	3	3	2									
CO 3	3	3	2									
CO 4	3	3	2									
CO 5	3	3	2									

Assessment Pattern

Bloom's Category	Continuous Assessment Tests		End Semester Examination
	1	2	
Remember	10	10	10
Understand	20	20	20
Apply	20	20	70
Analyse			
Evaluate			
Create			

## Mark distribution

Total Marks	CIE	ESE	ESE Duration
150	50	100	3 hours

### Continuous Internal Evaluation Pattern:

Attendance	: 10 marks
Continuous Assessment Test (2 numbers)	: 25 marks
Assignment/Quiz/Course project	: 15 marks

End Semester Examination Pattern: There will be two parts; Part A and Part B. Part A contain 10 questions with 2 questions from each module, having 3 marks for each question. Students should answer all questions. Part B contains 2 questions from each module of which student should answer any one. Each question can have maximum 2 sub-divisions and carry 14 marks.

### Course Level Assessment Questions

#### Course Outcome 1 (CO1):

1. In a reheat Rankine cycle, steam at a pressure of 40 bar and 300°C is expanded through a turbine to a pressure of 4 bar. It is then heated at a constant pressure to 300°C and then expanded to 0.1 bar. Estimate the work done per kg of steam flowing through the turbine, the amount of heat supplied during the reheat process and the cycle efficiency. Neglect pump work.
2. Explain the term boiler mountings and accessories
3. With the help of a figure explain the working of Babcock and Wilcox boiler.

#### Course Outcome 2 (CO2):

1. In an impulse steam turbine, steam issues from the nozzle with a velocity of 1200 m/s. The nozzle angle is 20° and the mean blade velocity is 400 m/s. The inlet and outlet blade angles are equal. The blade velocity coefficient is 0.8. The mass of steam flowing through the turbine per hour is 950 kg. Calculate: (i) Blade angles. (ii) Relative velocity of steam entering the blades (iii) Tangential force on the blades. (iv) Power developed. (v) Blade efficiency.
2. Derive the conditions for maximum efficiency of a Parsons reaction turbine.
3. Discuss the means of improving the performance of a steam turbine.



Course Outcome 3(CO3):

1. A 4-cylinder four stroke petrol engine is working based on the following data: Air-fuel ratio by weight = 15:1, calorific value of the fuel = 45000 kJ/kg, mechanical efficiency = 80 %, air- standard efficiency = 54 %, relative efficiency = 70 %, volumetric efficiency = 75 %, stroke/bore ratio = 1.25, suction conditions = 1 bar and 30 °C, r.p.m. = 2500, brake power = 70 kW. Calculate: (i) Compression ratio. (ii) Indicated thermal efficiency. (iii) Brake specific fuel consumption. (iv) Bore and stroke.
2. Discuss the working of a rotary engine and its merits and demerits over conventional IC engines.
3. Explain the performance testing of IC engines

Course Outcome 4 (CO4):

1. Explain equivalence ratio and its significance in IC engine combustion.
2. Explain different stages of SI engine combustion with the help of pressure-crank angle diagram.
3. Discuss detonation in SI engine, cause and effects and the engine variable influencing the same.

Course Outcome 5 (CO5):

1. Derive the expression for COP of an ideal air refrigeration cycle.
2. Explain the factors affecting human comfort
3. Write brief note on summer air conditioning

## MODEL QUESTION PAPER

### V SEMESTER BTECH DEGREE EXAMINATION

#### MET383: THERMAL SCIENCE AND ENGINEERING

Maximum: 100 Marks

Duration: 3 hours

*Use of Steam tables, Refrigeration tables, Charts and Psychrometric chart is permitted.*

#### PART A

Answer all questions, each question carries 3 marks

1. Explain Rankine cycle with help of a T-S diagram.
2. Differentiate between fire tube boiler and water tube boiler.
3. List the difference between throttle governing and nozzle governing.
4. Explain degree of reaction of a steam turbine.
5. Explain the term MEP
6. Explain the meaning of Specific Fuel
7. Explain the term Preignition
8. What do you mean by Octane number?
9. Why reversed Carnot cycle is practically impossible to execute?
10. Differentiate between specific humidity and relative humidity (10×3=30 Marks)

#### PART B

Answer one full question from each module

#### MODULE 1

11. a) Steam at a pressure of 15 bar and 250 °C is expanded through a turbine to a pressure of 4 bar. It is then reheated at constant pressure to initial temperature of 250 °C and finally expanded to condenser pressure of 0.1 bar. Calculate efficiency of the cycle. Pump work can be neglected. (8 marks)
- b) Explain in detail different boiler mountings and accessories. (6 marks)

12. a) With the help of a neat figure explain the working of a Benson boiler. What are its merits over other boilers? (8 marks)
- b) With the help of T-s and p-h diagram explain the significance of binary vapour cycle. (6 marks)

## MODULE 2

13. a) Derive the condition for maximum efficiency of a reaction turbine. (6 marks)
- b) With the help of figures enumerate the difference between pressure compounding and velocity compounding of steam turbines. (8 marks)
14. a) What do you mean by reheat factor? List the parameters influencing the value of reheat factor. (4 marks)
- b) In an impulse steam turbine, steam issues from the nozzle with a velocity of 1200 m/s. The nozzle angle is  $20^\circ$  and the mean blade velocity is 400 m/s. The inlet and outlet blade angles are equal. The blade velocity coefficient is 0.8. The mass of steam flowing through the turbine per hour is 950 kg. Calculate: (i) Blade angles. (ii) Relative velocity of steam entering the blades. (iii) Tangential force on the blades. (iv) Power developed. (v) Blade efficiency. (10 marks)

## MODULE 3

15. a) Discuss the terms a) Mechanical efficiency b) Volumetric Efficiency c) Thermal efficiency of an IC engine (9 marks)
- b) Discuss the effect of variable specific heat in actual cycle of IC engines. (5 marks)
16. The following observations were recorded during a trial of a four stroke single cylinder diesel engine for a trial duration of 30 min. Fuel consumption is 4 liters, Calorific value of fuel 43 MJ/kg, specific gravity of the fuel = 0.8, average area of indicator diagram =  $8.5 \text{ cm}^2$ , length of indicator diagram = 8.5 cm, spring constant = 5.5 bar/cm, brake load = 150 kg, spring balance reading = 20 kg, effective brake wheel diameter = 1.5 m, speed = 200 rpm, cylinder diameter = 30 cm, stroke = 45 cm. Calculate i) indicated power ii) brake power iii) mechanical efficiency iv) specific fuel consumption in kg/kWh and v) indicated thermal efficiency. (14 marks)

#### MODULE 4

17. a) With the help of pressure-crank angle diagram explain different stages of CI engine combustion. (8 marks)
- b) Explain the phenomenon of detonation in SI engine based on autoignition theory. (6 marks)
18. With the help of figures compare different types of SI and CI engine combustion chambers. (14 marks)

#### MODULE 5

19. a) A freezer of 20 TR capacity has evaporator and condenser temperature of  $-30\text{ }^{\circ}\text{C}$  and  $25\text{ }^{\circ}\text{C}$  respectively. The refrigerant R-12 is sub-cooled by  $4\text{ }^{\circ}\text{C}$  before entering the expansion valve and is superheated by  $5\text{ }^{\circ}\text{C}$  before entering the evaporator. If a six cylinder single acting compressor with stroke equal to bore running at 1000 rpm. is used. Determine i) COP ii) Theoretical piston displacement per minute iii) Theoretical bore and stroke. (9 marks)
- b) Derive an expression for COP of a Reversed Brayton cycle for air refrigeration system. (5 marks)
20. a) Explain the concept of summer air conditioning (10 marks)
- b) Define i) DPT ii) RH ii) SHF and iv) ADP. (4 marks)

## Syllabus

### Module 1

Steam engineering- Rankine cycle, Modified Rankine cycle, Relative efficiency, Improvement in steam cycles-Reheat, Regenerative and Binary vapour cycle. Steam Boilers: Types of boilers, Cochran boiler, Babcock and Wilcox boiler, Benson boiler, La Mont boiler, Boiler Mountings and Accessories.

### Module 2

Steam turbines: classification, compounding of turbines-pressure velocity variation, velocity diagrams, work done, efficiency, condition for maximum efficiency, multistage turbines-condition line, stage efficiency. Steam turbine performance-reheat factor, degree of reaction, cycles with reheating and regenerative heating, governing of turbines.

### Module 3

Actual cycle analysis of IC engines- Deviation of actual engine cycle from ideal cycle, Performance Testing of I C Engines- Indicator diagram, mean effective pressure. Torque, Engine power- BHP, IHP. Engine efficiency, mechanical efficiency, volumetric efficiency, thermal efficiency, relative efficiency and Specific fuel consumption.

### Module 4

Combustion in I.C. Engines- Analysis of fuel combustion-A/F ratio, equivalence ratio, excess air. Combustion phenomena in S.I. engines; Ignition limits, stages of combustion in S.I. Engines, Ignition lag, velocity of flame propagation, auto ignition, detonation; effects of engine variables on detonation; theories of detonation, octane rating of fuels; pre-ignition; S.I. engine combustion chambers. Combustion in C.I. Engines; delay period; variables affecting delay period; knock in C.I. engines, Cetane rating; C.I. engine combustion chambers.

### Module 5

Refrigeration– Reversed Carnot cycle, Air refrigeration system- Reversed Joule cycle. Vapour compression systems-simple cycle - representation on T- s and P- h Diagrams. Psychrometric properties – specific humidity, relative humidity and degree of saturation, thermodynamic equations, enthalpy of moisture, DBT, WBT and DPT, psychrometers, psychrometric chart. Comfort and industrial air conditioning, Comfort air conditioning-factors affecting human comfort, Effective temperature, comfort chart, Summer air conditioning

### Text Books

1. Rudramoorthy , Thermal Engineering, McGraw Hill Education India, 2003.
2. R.K Rajput, Thermal Engineering, Laxmi publications, 2010.
3. Arora C. P, Refrigeration and Air-Conditioning, McGraw-Hill, 2008.

4. Arora S. C. and Domkundwar, Refrigeration and Air-Conditioning, Dhanpat Rai, 2010.

#### Reference Books

1. V. Ganesan, Fundamentals of IC engines, Tata McGraw-Hill, 2002.

2. J.B.Heywood, I.C engine fundamentals. McGraw-Hill, 2011.

3. Rathore, Thermal Engineering, McGraw Hill Education India, 2010.

4. Dossat. R. J, Principles of Refrigeration, Pearson Education India, 2002.

5. Stoecker W.F, Refrigeration and Air-Conditioning, McGraw-Hill Publishing Company, 2009.

#### Course Contents and Lecture Schedule

No	Topic	No. of Lectures
1		
1.1	Steam engineering- Rankine cycle, Modified Rankine cycle, Relative efficiency, Improvement in steam cycles-Reheat, Regenerative and Binary vapor cycle.	4
1.2	Steam Boilers: Types of boilers, Cochran boiler, Babcock and Wilcox boiler, Benson boiler.	3
1.3	La Mont boiler, Boiler Mountings and Accessories.	2
2		
2.1	Steam turbines: classification, compounding of turbines-pressure velocity variation, velocity diagrams.	3
2.2	Work done, efficiency, condition for maximum efficiency, multistage turbines-condition line, stage efficiency.	3
2.3	Steam turbine performance-reheat factor, degree of reaction, cycles with reheating and regenerative heating, governing of turbines.	3
3		
3.1	Actual cycle analysis of IC engines- Deviation of actual engine cycle from ideal cycle	2
3.2	Performance Testing of I C Engines- Indicator diagram, mean effective pressure. Torque	2
3.3	Engine power- BHP, IHP. Engine efficiency, mechanical efficiency, volumetric efficiency, thermal efficiency	3
3.4	Relative efficiency, Specific fuel consumption.	2
4		
4.1	Combustion in I.C. Engines- Analysis of fuel combustion-A/F ratio, equivalence ratio, excess air.	1
4.2	Combustion phenomena in S.I. engines; Ignition limits, stages of combustion in S.I. Engines, Ignition lag, velocity of flame	3

	propagation, auto ignition, detonation; effects of engine variables on detonation; theories of detonation,	
4.3	Octane rating of fuels; pre-ignition; S.I. engine combustion chambers. Combustion in C.I. Engines; delay period; variables affecting delay period;	3
4.4	knock in C.I. engines, Cetane rating; C.I. engine combustion chambers.	2
5		
5.1	Refrigeration– Reversed Carnot cycle, Air refrigeration system- Reversed Joule cycle.	2
5.2	Vapour compression systems-simple cycle - representation on T- s and P- h Diagrams.	2
5.3	Psychometric properties – specific humidity, relative humidity and degree of saturation-	1
5.4	Thermodynamic equations- enthalpy of moisture- DBT, WBT and DPT–psychrometers, psychometric chart.	2
5.5	Comfort and industrial air conditioning, Comfort air conditioning- factors affecting human comfort, Effective temperature, comfort chart, Summer air conditioning,	2

COURSE CODE	COURSE NAME	CATEGORY	L	T	P	CREDITS
22MEMR509.3	MACHINE TOOLS ENGINEERING	MR	3	1	0	4

**Preamble:**

This course facilitate students to learn about various machine tools and operations performed on them. Theoretical foundation offered by this course must help the learners to make appropriate decisions vis-a-vis preliminary planning and selection of machine tools, acquiring adequate supervisory skills and to help the learners to efficiently interact with their peers to arrive at solutions for day-to-day shop floor problems.

**Prerequisite:**

MET285 Material Science and Technology (Minor), MET286 Manufacturing Technology (Minor)

**Course Outcomes:** After the completion of the course the student will be able to:

CO 1	Describe basic concepts involved in metal cutting.
CO 2	Differentiate between machine tools, their components, operations carried out and their unique metal removing mechanisms.
CO 3	Describe how to specify machine tools and cutting tools.
CO 4	Calculate the time required for machining.
CO 5	Clarify advantages of CNC over manual machine tools.
CO 6	Clarify how non-conventional machining techniques are advantageous to finish jobs with intricate profiles and closer tolerances.

**Mapping of course outcomes with program outcomes:**

	PO 1	PO 2	PO 3	PO 4	PO 5	PO 6	PO 7	PO 8	PO 9	PO 10	PO 11	PO 12
CO 1	3	-	-	-	-	-	-	-	2	-	-	-
CO 2	1	-	1	-	3	-	-	-	2	1	-	-
CO 3	-	-	-	2	-	-	-	-	2	-	1	-
CO 4	3	2	-	-	-	-	-	-	2	-	-	-
CO 5	-	-	-	-	2	-	-	-	2	-	-	2
CO 6	-	-	-	-	-	-	1	-	2	-	-	1



## Assessment Pattern

Bloom's Category	Continuous Assessment Tests		End Semester Examination (marks)
	1 (marks)	2 (marks)	
Remember	15	15	35
Understand	15	15	35
Apply	10	10	15
Analyse	10	10	15
Evaluate	-	-	-
Create	-	-	-

## Mark distribution

Total Marks	CIE	ESE	ESE Duration
150	50	100	3 hours

## Continuous Internal Evaluation Pattern:

Attendance	: 10 marks
Continuous Assessment Test (2 numbers)	: 25 marks
Assignment/Quiz/Course project	: 15 marks

End Semester Examination Pattern: There will be two parts; Part A and Part B. Part A contain 10 questions with 2 questions from each module, having 3 marks for each question. Students should answer all questions. Part B contains 2 questions from each module of which student should answer any one. Each question can have maximum 2 sub-divisions and carry 14 marks.

## Course Level Assessment Questions

### Course Outcome 1 (CO1):

1. Describe the geometry of a single point cutting tool with a neat diagram.
2. Define machinability.
3. List various cutting tool materials and their applications.

### Course Outcome 2 (CO2):

1. Examine two reasons for centre drilling on lathe.
2. Differentiate between up milling and down milling.
3. Differentiate a wire-cut EDM from a general purpose EDM.

Course Outcome 3 (CO3):

1. List all specification parameters of a lathe.
2. Specify a plain milling cutter.
3. Specify a twist drill.

Course Outcome 4 (CO4):

1. Calculate the time required for drilling a 20 mm hole in metal blank having thickness of 36 mm. The cutting speed is 15 metres/minute and feed is 0.2 mm/revolution.
2. Calculate the r.p.m. of lathe to obtain a cutting speed of 25 metres/minute, when turning a rod of diameter 32 mm diameter.
3. Calculate machining time for cylindrical grinding, if length of longitudinal travel =500 mm, feed =1.0 mm/revolution and work piece r.p.m = 500 in a single pass.

Course Outcome 5 (CO5):

1. Clarify whether a conventional machine tool can be retrofitted with a CNC system.
2. Describe advantages of CNC system in manufacturing.
3. Distinguish between open loop system and closed loop system by giving an example for each.

Course Outcome 6 (CO6):

1. Describe advantages of WJM over traditional punching/manual cutting
2. Compare process capabilities of conventional drilling and laser beam drilling.
3. Clarify why an EDM is not used as a replacement to CNC milling machine.

MODEL QUESTION PAPER  
FIFTH SEMESTER MECHANICAL ENGINEERING  
MET385 MACHINE TOOLS ENGINEERING

Max. Marks: 100

Duration: 3 hours

Part–A

Answer all questions. Each question carries 3 marks.

1. State the effect of cutting speed, feed and depth of cut on surface finish obtainable.
2. Explain why built up edge on a tool is undesirable.
3. A brass pin of 500 mm length and 40 mm diameter is turned on a lathe to 38.8 mm diameter in one pass. The cutting speed is 60 metres/minute and feed is 0.8 mm/min. Calculate the machining time.
4. How do you specify (a) portable drilling machine (b) radial drilling machine (c) multiple spindle drilling machine.
5. List various operations that can be performed on a milling machine.
6. Differentiate between grain and grade in a grinding wheel.
7. Bring out the differences between continuous path control and point-to-point positioning.
8. List the generic advantages of CNC system over their manual counterparts.
9. Discuss the characteristics of dielectric fluids used in EDM.
10. List the advantage of WJM over traditional cutting.

Part–B

Answer one full question from each module.

Module I

11. (a) Sketch the three views of a 25 mm single point square tool bit having tool signature as indicated below: 15,15,10,10,15,10 (3 mm) (7 marks)
- (b) Define machinability. Discuss all variables affecting machinability. (7 marks)
12. (a) Discuss various cutting tool materials and their applications.
- (b) Define tool failure. List and explain 2 reasons for normal tool wear. (7 marks)

Module II

13. Describe construction details of an engine lathe with a neat illustration. (14 marks)
14. Draw and explain any four operations carried out in a lathe. (14 marks)

Module III

15. Draw and explain up milling and down milling. Decide which type is suitable to prevent backlash. (14 marks)

16. List all factors to be considered for selection of grinding wheels. Discuss each in detail. (14 marks)

#### Module IV

17. Discuss all elements of a CNC system with a suitable block diagram. (14 marks)

18. Discuss construction details of a CNC lathe and compare process capability of CNC lathe with that of a manual lathe. (14 marks)

#### Module V

19. Describe ultrasonic drilling process giving areas of application. (14 marks)
20. Discuss construction and operation of a wire-cut EDM system with the help of a suitable diagram. (14 marks)

### Syllabus

#### Module 1

Definition of machining–brief history of machining–role of machining in society. Introduction to metal cutting: Elements of cutting process– orthogonal cutting– mechanism of chip formation–machining variables -types of chips–chip breaker– geometry of single point cutting tool– tool nomenclature- speed, feed, depth of cut – cutting fluids- effect of machining variables on surface roughness- Cutting tool materials–types–application. Machinability–tool life and wear.

#### Module 2

General purpose machine tools – Lathe: principle of operation of lathe–construction details of lathe–work holding and tool holding parts of lathe– types of lathe and specification–machining time calculation on lathe–main operations. Drilling Machines: principle of operation–construction details- work holding and tool holding devices– types of drilling machine and specification. Twist drill geometry–specification–calculation of machining time in drilling.

#### Module 3

Milling machines: Principle of operation of milling machine–types and specifications–principal parts–work holding devices–types of milling cutters–elemental milling motions–up milling, down milling calculation of machining time. Grinding machines: classification –operations– surface, cylindrical and centerless grinding–grinding wheels–specification–types of abrasives, grain size. Dressing and truing of grinding wheels–selection of grinding wheels.

#### Module 4

Machine tools with Computer Numeric Control: Principle of operation of CNC system–basic components of CNC system– classification of CNC systems– open loop control and closed loop

control– point to point and continuous path control– absolute positioning and incremental positioning–CNC lathe–construction and operation – CNC milling machine–construction and operation (elementary treatment only)

## Module 5

Non-conventional techniques in machining: Electric Discharge Machining (EDM): mechanisms of metal removal- elements of an EDM– spark generation– application of EDM – Wire-cut EDM-features. UltraSonic Machining (USM): mechanism of metal removal- elements of USM- applications. Water Jet Machining (WJM): mechanism of metal removal-elements of WJM- applications.

### Text Books

1. R.K.Jain, Production Technology, Khanna publishers, 17<sup>th</sup> ed., 2013.
2. Hajra Choudhary, Elements of Workshop Technology Vol. II, Media Promoters & Publishers Pvt. Ltd., 2010.

### Reference Books

1. Serope Kalpakjian, Steven R. Schmid – Manufacturing Engineering and Technology, 8<sup>th</sup> ed. Pearson.
2. Chapman W.A.J., Workshop Technology, Viva books (P) Ltd, 1998.
3. Peter J. Hoffman, Eric S. Hopewell et al., Precision Machining Technology, Cengage Learning, 2014.
4. Malkin Stephen, Grinding Technology: Theory and application of Machining with Abrasives, Industrial press, 2008.

### Course Contents and Lecture Schedule

No	Topic	No. of Lectures	COs
1.1	Definition of Machining–brief history of machining–role of machining in society – automotive- aerospace– medical–consumable goods.	1	CO1
1.2	Introduction to metal cutting–elements of cutting process–work piece-tool interaction in orthogonal cutting- rake angle, shear angle, cutting angle, clearance angle–mechanism of chip formation–chip breaker.	1	CO1
1.3	Machining variables- geometry of chips (types of chips)- cutting speed, feed, depth of cut- tool geometry ( single point)-nomenclature-cutting fluids.	3	CO1
1.4	Effect of machining variables on surface roughness.	2	CO1
1.5	Cutting tool materials and application.	1	CO1
1.6	Machinability-factors affecting it –machinability index.	1	CO1
1.7	Tool life and tool wear.	1	CO1
2.1	General purpose machine tools– lathe- principle and operation of lathe-how to specify a lathe-types of lathe.	1	CO2 CO3
2.2	Construction details of engine lathe-work holding and tool holding parts of lathe.	2	CO2
2.3	Main operations in lathe- machining time calculation of plain turning.	2	CO4

2.4	Drilling machines – principle of operation-construction details.	1	CO2
2.5	Work holding and tool holding devices.	2	CO2
2.6	Types of drilling machine- specification of radial drilling machine.	1	CO3
2.7	Twist drill geometry and specification- calculation of drilling time.	1	CO4
3.1	Milling machine- purpose and principle of operation-types an specification.	1	CO2
3.2	Differentiate Horizontal milling machine and vertical milling machine – principal parts and work holding devices of vertical milling machine.	1	CO2
3.3	Types of milling cutters- elemental milling movements- up milling, down milling – calculation of plain milling time.	2	CO4
3.4	Grinding machines- classification- surface, cylindrical and centre less grinding.	1	CO2
3.5	Grinding wheels–specification–types of abrasives, grain size–dressing and truing of grinding wheels–selection of grinding wheels.	3	CO3
4.1	Machine tools with CNC- principle of operation of CNC – basic components (block diagrams)	2	CO2
4.2	Classification of CNC systems– open loop control and closed loop control– point-to-point and continuous path control– absolute positioning and incremental positioning.	2	CO5
4.3	CNC lathe- construction and operation ( elementary treatment)	2	CO5
4.4	CNC milling machine- construction and operation ( elementary treatment)	2	CO5
5.1	Non-conventional techniques in machining: Electric Discharge machining (EDM): mechanism of metal removal- elements of an EDM– physics of spark generation.	2	CO6
5.2	Applications of EDM process.	1	CO6
5.3	Wire-cut EDM-features and applications.	1	CO6
5.4	Ultrasonic Machining (USM): mechanism of metal removal- elements of USM-applications.	2	CO6
5.5	Water Jet Machining (WJM): mechanism of metal removal-elements of WJM- applications.	2	CO6

---

SEMESTER V

---

HONOURS

---





## Assessment Pattern

Blooms Category	Continuous Assessment Tests		ESE
	1	2	
Remember			
Understand	40	40	80
Apply		10	10
Analyse	10		10
Evaluate			
Create			

## Mark Distribution

Total Marks	CIE	ESE	ESE Duration	
150	50	100	3 Hrs	

## Continuous Internal Evaluation Pattern

Attendance	10
Continuous Assessment Tests ( 2 nos)	25
Assignments/ Quiz/ Course Project	15

End Semester Examination Pattern: There will be two parts; Part A and Part B. Part A contain 10 questions with 2 questions from each module, having 3 marks for each question. Students should answer all questions. Part B contains 2 questions from each module of which student should answer any one. Each question can have maximum 2 sub-divisions and carry 14 marks.

## COURSE LEVEL ASSESSMENT QUESTIONS

Course Outcome 1 (CO1): Analyse the stresses, strains and deformations of structures under 2- and 3-dimensional loading by tensorial and graphical (Mohr's circle) approaches.

1. Determine the resultant traction at a point in a plane using the stress tensor.
2. Evaluate the principal stresses, principal strains and their directions from a given state of stress or strain.
3. Write the stress tensor and strain tensor.

Course Outcome 2 (CO2): Describe the different instrument used for strain measurement materials using stress-strain relationships.

1. With help of fig, explain the construction and working of any one type of strain gauge.
2. Explain how strain can be measured over a long time at high and low temperature.
3. Explain how the delta rosette can be used for analysing the strain.

Course Outcome 3 (CO3): Describe the concept behind the measurement and instrumentation.

1. Describe Range and Sensitivity of a circuit
2. Define error, accuracy and precision with respect to measuring instrument.
3. With help of fig, Describe any one type of displacement measuring transducer.

Course Outcome 4 (CO4): Describe the concept behind Photo elasticity and brittle Coating.

1. Enumerate different steps involved in brittle coating.
2. Describe the effect of stressed model in plane polariscope.
3. Describe compensation techniques in photo elasticity.

Course Outcome 5 (CO5): Describe the different NDT methods to evaluate the strength.

1. Describe dye penetrant test with help of figure.
2. Explain penetrometer with help of figure.
3. With help of figure, explain Magnetic particle test.

## MODEL QUESTION PAPER

### FIFTH SEMESTER B.TECH DEGREE EXAMINATION

### MET 393 EXPERIMENTAL STRESS ANALYSIS

Max. Marks:100

Duration: 3Hours

#### PART – A

*(ANSWER ALL QUESTIONS, EACH QUESTION CARRIES 3 MARKS)*

1. Define stress at a point.
2. Explain principal stresses and strain.
3. How static and dynamic strain can be measured over a strain circuits.
4. What are residual stresses? What are its beneficial and harmful effects?
5. What are transducers? What are its properties?
6. Explain the different principles of measurements
7. Define stress optic law
8. What are the main uses of photo elastic coatings?
9. Distinguish between Destructive testing and Non-destructive testing.
10. What are the properties of X rays and Gamma rays.

#### PART – B

*(ANSWER ONE FULL QUESTION FROM EACH MODULE)*

#### MODULE – 1

11. The state of stress at a point is given by the Cartesian stress tensor
- $$\begin{pmatrix} 3 & -1 & 1 \\ -1 & 5 & -1 \\ 1 & -1 & 3 \end{pmatrix}$$
- Kpa. Find (a) the stress invariant (b) characteristic equation (c) Principal stresses (d) Unit normal of the principal planes. (14marks)
12. a) Derive the expression for Cauchy's equation for stress on a given plane, normal stress & shear stress. (7marks)

b) Derive stress compatibility equation of plane strain problems. (7marks)

#### MODULE – 2

13. a) With help of neat sketch, explain a mechanical strain gauge (7 marks)

b) Explain how rectangular rosette can be analyzed for strain measurement. (7 marks)

14. a) With help of fig, explain a optical strain gauge. (7 Marks)

b) Describe how strain can be measured over a long period at low and high temperature.

(7 marks)

#### MODULE – 3

15. a) with help of figure, explain the working of cathode ray oscilloscope. (7 marks)

b) With help of fig, explain the working of displacement transducer. (7 marks)

16. a) Prove that constant current potentiometer circuit has more sensitivity than that of a constant voltage circuit (7 marks)

b) With help of fig, explain the working of force transducer. (7 marks)

#### MODULE – 4

17 a) Describe the different types of available brittle coatings. (7marks)

b) Obtain the expression for intensity of light emerging from a plane polariscope with dark field set up. (7marks)

18 a) With help of fig, explain Tardy's method of compensation. (10 marks)

b) Explain isochromatic and isoclinics fringe pattern (4 marks)

#### MODULE – 5

19. a) Explain laser testing methods in NDT. (7 marks)

b) With help of fig, explain the steps involved in LPI. (7 marks)

20. a) With help of fig, explain Radiography test. (7 marks)

b) Explain the working of X – ray fluoroscopy (7 marks)

## SYLLABUS

Module 1: Analysis of deformable bodies: stress, stress at a point using Cartesian stress tensor, Cauchy's equation for stress on a given plane, normal stress & shear stress; Strain, deformation and displacement (in Cartesian coordinates), strain components, 2D plane stress and plane strain problems, principal stresses (2D & 3D), stress invariants, Mohr's circle representation for stress in 2D and problems, representation 3D stress in Mohr's circle using principal stresses as input.

Module 2: Strain measurements: strain gauges and stress gauges. Mechanical, optical and electrical gauges – Construction and applications. Variable resistance strain gauges, gauge characteristics, gauge sensitivity, static and dynamic strain – strain measurement over a long period at low and high temperature. Strain rosettes – Rectangular rosettes, Delta rosettes. Residual stresses : Beneficial and harmful effects.

Module 3: Instrumentation: Strain circuits, potentiometer circuits, Range and sensitivity, The wheatstones bridge, sensitivity, Galvanometer, Transient response, Principles of measurements: Error, Accuracy and precision , Uncertainty analysis, Curve fitting. Oscillograph, cathode ray oscilloscope, Transducers – Displacement, Force, Pressure, velocity and acceleration.

Module 4: Photo elasticity: The polariscope, Stress optic law, Polariscope arrangements – Plane polariscope and Circular Polariscope. Dark field and light field, isochromatic and isoclinics, Use of photo elastic coatings, compensation techniques. Brittle coatings: Coating stresses, Failure theories, steps in brittle coating tests.

Module 5: Non Destructive testing Methods – Types – dye penetrant methods, Radiography – X – ray and Gamma ray – X – ray fluoroscopy. Penetrameter – Magnetic particle methods. Introduction to lasers in NDT – Ultrasonic flaw detection.

### Text Books

1. J. W. Dally and W. F. Riley, Experimental Stress Analysis – McGraw Hill, 1991
2. L.S.Srinath, M R Raghavan, K Lingaiah, G Gargesa, B Pant, and K . Ramachandra, Experimental Stress Analysis, Tata Mc Graw Hill, 1984.
3. A. Mubin, Experimental Stress Analysis, Khanna Publishers, 2003 .
4. Sadhu Singh, Experimental Stress Analysis, Khanna Publishers, 1996.

### Reference Books

1. M. Hetenyi, Handbook of Experimental Stress Analysis, John Wiley & Sons Inc, New York, 1950
2. C.C. Perry and H.R. Lissener, Strain Gauge Primer, McGraw Hill, 2<sup>nd</sup> Ed., 1962 .

3. W.J. McGonagle -Non-destructive Testing -Mc Graw Hill, 1961 .

### COURSE PLAN

No	Topic	No. of Lectures
1	Module 1: Stress and Strain Analysis	9 hrs
1.1	Describe the deformation behaviour of elastic solids in equilibrium under the action of a system of forces. Describe method of sections to illustrate stress as resisting force per unit area. Stress vectors on Cartesian coordinate planes passing through a point .	1 hr
1.2	Direction cosines of a plane. Equality of cross shear (Derivation not required). Write Cauchy's equation (Derivation not required) for stress on a plane as the product of stress tensor and direction cosine vector. Normal and tangential (shear) components of stress on a plane.	1 hr
1.3	Deformation, displacement, gradient of deformation and strains in elastic solids. Cartesian components of strain and Cauchy's strain-displacement relationships (small-strain only). Strain tensor in 2D and 3D. Write the stress tensor and strain tensor for Plane stress and Plane Strain analysis.	1 hr
1.4	Stress on an oblique plane under axial loading, Discuss principal planes, characteristic equation to find principal stresses for 2D and 3D state of stress, stress invariants. Evaluate principal stresses in 2D and 3D using characteristic equations.	2 hrs
1.5	Discuss the order of principal stress and maximum shear stress. Compare the principal stresses in 2D and 3D state of stress. Represent the state of stress using principal stress tensor. Determine the direction of principal stresses as eigenvectors of the principal stress tensor.	2 hrs
1.6	Represent the 2D and 3D state of stress using principal stress graphically (Mohr's circle). Determine the maximum shear stress by Mohr's circle method and compare with the theoretical relations.	2 hrs
2	Module 2: Strain measurements	8 hrs
2.1	Strain gauges and stress gauges, Different types of strain gauges – construction and working, Different application of strain gauges. Variable resistance strain gauge	2 hr
2.2	Gauge characteristics, gauge sensitivity, measurement of static and dynamic strain, and measurement of strain over a long period at high and low temperature.	2 hrs
2.3	Strain rosette - Rectangular rosettes and Delta rosettes (simple problems).	2 hrs
2.4	Residual stresses, harmful effects of residual stresses, beneficial effects of residual stresses.	2 hrs
3	Module 3 :Instrumentation	9 hrs
3.1	Strain circuits, potentiometer circuits, Range and sensitivity, The wheatstones bridge.	2 hrs
3.2	Principles of measurements: Error, Accuracy and precision,	1 hr

	Uncertainty analysis, Curve fitting.	
3.3	Oscillograph ,cathode ray oscilloscope,	1 hr
3.4	Transducer – Characteristics and properties.	1 hr
3.5	Displacement transducer – Construction and working, Pressure transducer - Construction and working.	2 hrs
3.6	Velocity transducer - Construction and working	1 hr
3.7	Acceleration transducer - Construction and working.	1 hr
4	Module 4 : Photoelasticity.	8 hrs
4.1	The polariscope, Stress optic law, Polariscope arrangements – Plane polariscope and Circular Polariscope.	2 hrs
4.2	Dark field and light field , isochromatics and isoclinics , Use of photoelastic coatings.	2 hrs
4.3	Different types of compensation techniques.	2 hrs
4.4	Coating stresses, Failure theories, steps in brittle coating tests.	2 hr
5	Module 5 :Non Destructive Methods.	8 hrs
5.1	Non Destructive testing Methods – Types – dye penetrant methods, Radiography – X – ray and Gamma ray.	2 hrs
5.2	X – ray fluoroscopy , Penetrameter (Detailed description)	2 hr
5.3	Magnetic particle methods, advantages and disadvantages, applications.	2 hrs
5.4	Introduction to lasers in NDT – Ultrasonic flaw detection.	2 hrs

COURSE CODE	COURSE NAME	CATEGORY	L	T	P	CREDITS
22MEHR510.2	ADVANCED THERMODYNAMICS	HR	3	1	0	4

Preamble: This course involves the application of principles studied in thermodynamics for analysis of thermal energy systems. This course also covers the properties of pure substances, Energy balance of reacting systems and advances in chemical thermodynamics.

Course Outcomes: After the completion of the course the student will be able to

CO 1	Apply the concepts of basic thermodynamics, entropy and energy for analyses of thermal energy systems.
CO 2	Understand properties of pure substance and thermodynamic properties of real gases
CO 3	Apply energy balances to reacting systems for both closed and open system.
CO 4	Define the chemical equilibrium constant and apply the general criteria for chemical equilibrium analysis to reacting ideal-gas mixtures.

Mapping of course outcomes with program outcomes

	PO 1	PO 2	PO 3	PO 4	PO 5	PO 6	PO 7	PO 8	PO 9	PO 10	PO 11	PO 12
CO 1	3	3	2									
CO 2	3	3	2									
CO 3	3	3	2									
CO 4	3	3	2									

Assessment Pattern

Bloom's Category	Continuous Assessment Tests		End Semester Examination
	1	2	
Remember	10	10	10
Understand	10	10	20
Apply	20	20	50
Analyse	10	10	20
Evaluate			
Create			

Mark distribution

Total Marks	CIE	ESE	ESE Duration
150	50	100	3 hours



### Continuous Internal Evaluation Pattern:

Attendance	: 10 marks
Continuous Assessment Test (2 numbers)	: 25 marks
Assignment/Quiz/Course project	: 15 marks

End Semester Examination Pattern: There will be two parts; Part A and Part B. Part A contain 10 questions with 2 questions from each module, having 3 marks for each question. Students should answer all questions. Part B contains 2 questions from each module of which student should answer any one. Each question can have maximum 2 sub-divisions and carry 14 marks.

### Course Level Assessment Questions

#### Course Outcome 1 (CO1):

1. One kg of water at 273 K is brought into contact with a heat reservoir at 373 K. When the water has reached 373 K, find the entropy change of water, of the heat reservoir and of the universe.
2. State and prove Clausius Theorem
3. Water at 363 K flowing at the rate of 2 kg/s mixes adiabatically with another stream of water at 303 K flowing at the rate of 1 kg/s. Estimate the entropy generation rate and rate of exergy loss due to mixing. Take  $T_0 = 300$  K

#### Course Outcome 2 (CO2)

1. A large insulated vessel is divided into two chambers one containing 5 kg of dry saturated steam at 0.2 MPa and the other 10 Kg of steam 0.8 quality at 0.5 MPa. If the partition between the chambers is removed and the steam is mixed thoroughly and allowed to settle, find the final pressure, steam quality and entropy change in the process
2. Draw the phase equilibrium diagram for a pure substance on h-s plot with relevant constant property lines.
3. Show that for an ideal gas the slope of the constant volume line on the T-S diagram is more than that of the constant pressure line.

#### Course Outcome 3(CO3):

1. Determine the adiabatic flame temperature when liquid octane at 298 K is burned with 300% theoretical air at 298 K in a steady flow process
2. What is heat of reaction? When is it positive and when negative?

3. Calculate the degree of ionization of cesium vapour at  $10^{-6}$  atm at the two temperatures of 2260 and 2520 K

Course Outcome 4 (CO4):

1. Explain law of mass action
2. Explain reaction equilibrium constant.
3. Discuss second law analysis of reactive systems

## MODEL QUESTION PAPER

### V SEMESTER BTECH DEGREE EXAMINATION

#### MET395: ADVANCED THERMODYNAMICS

Maximum: 100Marks

Duration:3 hours

### PART A

Answer all questions, each question carries 3 marks

1. Show that entropy is a property of the system
2. What is the meaning of quality of energy
3. Draw the phase equilibrium diagram for a pure substance on T-s plot with relevant constant property lines.
4. Write Clausius – Clapeyron equations
5. Explain law of corresponding states
6. Explain Vander-Waals equation of state
7. Explain Second-Law Analysis of Reacting systems
8. What do you meant by adiabatic flame temperature?
9. Explain law of mass action
10. What is van't Hoff equation

(10×3=30Marks)

## PART B

Answer one full question from each module

### MODULE 1

11. Three identical finite bodies of constant heat capacity are at temperatures 300, 300 and 100 K. If no work or heat is supplied from outside, what is the highest temperature to which any one of the bodies can be raised by the operation of heat engines or refrigerators (14 marks)

12. A pressure vessel has a volume of  $1\text{m}^3$  and contains air at 1.4 MPa, 448K. The air is cooled to 298K by heat transfer to surroundings at 298 K. Calculate the availability in the initial and final states and irreversibility of the process. Take  $P_0 = 100\text{kPa}$  (14 marks)

### MODULE 2

13. Steam initially at 0.3 MPa, 523K is cooled at constant volume. Find

- a) Temperature at which steam become saturated vapour,
  - b) What is the quality at 353 K,
  - c) What is the heat transferred per kg of steam in cooling from 523 K to 353 K
- (14 marks)

14. Derive Maxwell relations and TdS equations (14 marks)

### MODULE 3

15. a) What are virial coefficients ? When do they become zero? (7 Marks)

b) Express Vander – Walls constants in terms of critical properties (7 marks)

16. Calculate the volume of 2.5 Kg moles of steam at 236.4 atm. And 776.76 K with the help of compressibility factor vs reduced pressure graph. At this given volume and pressure what would be the temperature in K, if steam behaves like a Vander-Walls gas. The critical pressure, volume and temperature of steam are 218.2 atm,  $57\text{ cm}^3/\text{g}$  mole and 647.3 K respectively.

(14 marks)

#### MODULE 4

17. a) Explain second law efficiency of a reactive system ? (4 marks)
- b) Explain first law analysis of reactive systems. (10 Marks)

18. The products of combustion of an unknown hydrocarbon  $C_xH_y$  have the following composition as measured by an Orsat apparatus

$CO_2$  8%,  $CO$  0.9%,  $O_2$  8.8% and  $N_2$  82.3 % Find a) Composition fuel b) air-fuel ratio and c) percentage of excess air used. (14 marks)

#### MODULE 5

19. a) What is Gibbs function of formation (5 marks)
- b) Explain the phase equilibrium for a single component system (9 marks)
20. a) What is degree of reaction (5 marks)
- b) Explain the phase equilibrium for a multi component system (9 marks)

## Syllabus

### Module 1

RECAPITULATION OF FUNDAMENTALS. Basic definition and concepts; The basic laws of Thermodynamics, Entropy flow and entropy production, 3rd law of Thermodynamics, Availability in steady flow open system and in a closed system, Irreversibility and effectiveness.

### Module 2

PROPERTIES OF PURE SUBSTANCES. P-V-T surfaces, phase diagram, phase changes, various properties diagram, 1st order phase transition and 2nd order phase transition, Clapeyron's equation, Ehrenfest's equations, Maxwell's equations, equation for internal energy, enthalpy, entropy, specific heat and Joule Thompson coefficient.

### Module 3

EQUATION OF STATE FOR REAL GASES. Compressibility factor and generalised compressibility chart, Law of corresponding state, law of pseudo critical pressure and temperature, reduced coordinate, Vander-Waals equation of state and other equation of state.

### Module 4

CHEMICAL REACTION. Fuels and Combustion, First-Law Analysis of Reacting Systems: Steady-Flow Systems and Closed Systems, Entropy Change of Reacting Systems, Second-Law Analysis of Reacting systems.

### Module 5

CHEMICAL THERMODYNAMICS. Gibb's theorem, Gibb's function of mixture of inert ideal gases, Chemical equilibrium, Thermodynamic equation for phase, Degree of reaction, equation of reaction, law of mass action, heat of reaction and Vant Hoff Isober, Phase Equilibrium for a Single-Component System and Multi-Component System

#### Text books:

1. Richard Edwin Sonntag , G.J. Van Wylen, Introduction to Thermodynamics- Classical and Statistical Wiley , 1991
2. Cengel and Boles., Thermodynamics : An engineering Approach McGraw-Hill, 2007 Sixth Edition
3. P.K. Nag. Engineering Thermodynamics Tata McGraw -Hill , 2013

#### Reference books:

1. M. Zemansky, R H Dittman. Heat and Thermodynamics –7<sup>th</sup> Edition 1998
2. E. F . Obert, Concepts of thermodynamics – McGraw-Hill, 1963

Course Contents and Lecture Schedule

No	Topic	No. of Lectures
1		
1.1	Basic definition and concepts; The basic laws of Thermodynamics,	3
1.2	Entropy flow and entropy production, 3rd law of Thermodynamics,	2
1.3	Availability in steady flow open system and in a closed system	2
1.4	Irreversibility and effectiveness.	2
2		
2.1	PROPERTIES OF PURE SUBSTANCES. P-V-T surfaces, phase diagram, phase changes, various properties diagram,	3
2.2	1st order phase transition and 2nd order phase transition, Clapeyron's equation, Ehrenfest's equations,	3
2.3	Maxwell's equations, equation for internal energy, enthalpy, entropy, specific heat and joule Thompson coefficient.	3
3		
3.1	EQUATION OF STATE FOR REAL GASES. Compressibility factor and generalised compressibility chart,	2
3.2	Law of corresponding state	2
3.3	law of pseudo critical pressure and temperature	3
3.4	Reduced coordinate, Vander-Waals equation of state and other equation of state.	2
4		
4.1	CHEMICAL REACTION. Fuels and Combustion,	1
4.2	First-Law Analysis of Reacting Systems: Steady-Flow Systems and Closed Systems	3
4.3	Entropy Change of Reacting Systems	2
4.4	Second-Law Analysis of Reacting systems	3
5		
5.1	CHEMICAL THERMODYNAMICS. Gibb's theorem, Gibbs function of mixture of inert ideal gases,	2
5.2	Chemical equilibrium, Thermodynamic equation for phase,	2
5.3	Degree of reaction, equation of reaction, law of mass action,	2
5.4	Heat of reaction and Vant Hoff Isober, Phase Equilibrium for a Single-Component System and Multi-Component System	3

COURSE CODE	COURSE NAME	CATEGORY	L	T	P	CREDITS
22MEHR510.3	FLUID POWER AUTMATION	HR	3	1	0	4

Preamble :

This course provides basic ideas of fluid power automation. It enables the students to design and optimize pneumatic and hydraulic automation systems.

Prerequisite : Nil

Course Outcomes :

After completion of the course the student will be able to

CO1	Explain the concept of power generating elements
CO2	Describe fundamentals of actuator and accumulator
CO3	Explain in detail control and regulation elements
CO4	Illustrate different circuit design methods
CO5	Illustrate electrical control of pneumatic and hydraulics circuits

Mapping of course outcomes with program outcomes

	PO1	PO2	PO3	PO4	PO5	PO6	PO7	PO8	PO9	PO10	PO11	PO12
CO1	3	2	1									
CO2	3	2										
CO3	3	2	1									
CO4	3	1										
CO5	3	1										

Assessment Pattern

Bloom Category	Continuous Assessment Tests		End Semester Examination
	1	2	
Remember	10	10	10
Understand	20	20	20
Apply	20	20	70
Analyse			
Evaluate			
Create			

Mark Distribution and duration of ESE

Total Marks	CA	ESE	ESE Duration
150	50	100	3 Hours

Continuous Internal Evaluation Pattern

Attendance : 10 marks

Continuous Assessment Test (2 numbers) : 25 marks

Assignment/Quiz/Course project : 15 marks

End semester pattern:

There will be two parts; Part A and Part B. Part A contain 10 questions with 2 questions from each module, having 3 marks for each question. Students should answer all questions. Part B contains 2 questions from each module of which student should answer any one. Each question can have maximum 2 sub-divisions and carry 14 marks.

Course Level Assessment Questions:

Course Outcome 1 (CO1):

1. Explain the need and benefits of automation.
2. Discuss the various components of a fluid power system.
3. Discuss about the hydraulic and pneumatic element selection criteria based with respect to a typical example.

Course Outcome 2 (CO2):

1. Write a detailed note on Linear Actuators.
2. Give a short notes on (a) Spring Return Single acting Cylinder and (b) Double acting cylinder with a piston rod on both sides
3. Make a circuit sketch showing the use of accumulators as a shock absorber.

Course Outcome 3 (CO3):

1. Explain different types of direction and flow control valves.
2. Explain the components of closed loop hydraulic systems with a block diagram.
3. With a neat sketch, describe the construction and working of pressure compensated flow control valve.

Course Outcome 4 (CO4):

1. Construct a ladder diagram for a hydraulic circuit with six cylinders used to control industrial robot.
2. Describe combinational and sequential logical circuits.
3. Design and develop a hydraulic circuit for the following sequence using cascade method. A+ B+ C+

Course Outcome 5 (CO5):

1. Explain basic electrical devices used in electro pneumatic circuits.
2. Explain the functions of relays, timers and counters in hydraulic and pneumatic circuits.
3. Explain the basic structure of a PLC.



MODEL QUESTION PAPER  
V SEMESTER B.TECH DEGREE EXAMINATION  
MET397: FLUID POWER AUTOMATION

Maximum: 100 Marks

Duration: 3 hours

PART A

Answer all questions, each question carries 3 marks

1. What are the limitations of fluid power automation?
2. What are the factors to be considered in the selection of pump?
3. Define spool valve?
4. How is counter represented in ladder diagram?
5. What is a linear actuator?
6. What is the function Karnaugh map?
7. Define underlap and overlap in the context of servo valve spools?
8. What are the uses of relays in hydraulic and pneumatic circuits?
9. What is the function of intensifier?
10. List the components of PLC. (10 X 3 = 30 marks)

PART B

Answer one full question from each module

Module 1

11. Describe in brief with neat sketches any 16 ISO symbols used for fluid power elements. (14 marks)
12. Briefly explain the working and construction details of Vane pump with a diagram (14 marks)

Module 2

13. Describe the working principle of hydraulic accumulators (14 marks)
14. With a neat sketch, explain the end cushion provided in hydraulic cylinder (14 marks)

Module 3

15. Draw a neat sketch and explain the working of pressure and temperature compensated flow control valve (14 marks)
16. Write short notes on direction control valves and its types with neat sketches (14 marks)

Module 4

17. Draw and explain the working principle of fail-safe circuit with overload protection (14 marks)
18. Design and draw a hydraulic circuit for A+B+B+A+ sequencing operation and explain. (14marks)

Module 5

19. Design and draw electro hydraulic circuit for hydraulic motor braking system (14 marks)

20. a) Draw the fluid power symbols of any 4 accessories (4 marks)  
b) Describe the advantages and disadvantages of fluid power systems

(10 marks)

### Syllabus

#### Module 1

Need for automation, classification of drives- hydraulic and pneumatic –comparison ISO symbols for fluid power elements, selection criteria Fluid power generating elements-hydraulic pumps and motorgears, vane, piston pumps-motors-selection and specification

#### Module 2

Drive characteristics- linear actuator–types, mounting details, cushioning–power packs–accumulators

#### Module 3

Control and regulation elements—direction, flow and pressure control valves-methods of actuation, types, sizing of ports. Spool valves- operating characteristics, electro hydraulic servo valves-different types-characteristics and performance

#### Module 4

Typical design methods –ladder diagram- sequencing circuits design - combinational logic circuit design-cascade method - Karnaugh map method.

#### Module 5

Electrical control of pneumatic and hydraulic circuits- use of relays, timers, counters, interfacing with PLCs, proportional control of hydraulic systems

#### Text Books:

1. Alavudeen A, Fluid Power Transmission and Control, Charotar Publishing House, 2007
2. Jagadeesha T, Hydraulics and Pneumatics, I K International Publishing House, 2015
3. AntonyEsposito,FluidPowerSystemsandcontrol,Prentice-Hall,1988

#### Reference Books:

1. PeterRohner,FluidPowerlogiccircuitdesign, MacmillanPress, 1994.
2. E.C.FitchandJ.B.Surjaatmadja.Introductiontofluidlogic,McGrawHill, 1978
3. HerbertE.Merritt,Hydrauliccontrolsystems,JohnWiley&Sons,1967
4. Dudley.A.Pease,BasicFluidPower,PrenticeHall,1967

Course Contents and Lecture Schedule

No.	Topic	No. of Lectures
I	Need for automation, classification of drives- hydraulic and pneumatic – comparison, ISO symbols for fluid power elements, selection criteria	4
	Fluid power generating elements – hydraulic pumps and motorgears, vane, piston pumps-motors- selection and specification	5
II	Drive characteristics- linear actuator-types, mounting details, cushioning–power packs–accumulators	9
III	Control and regulation elements–direction, flow and pressure control valves- methods of actuation, types, sizing of ports, spool valves-operating characteristics, Electro hydraulic servo valves-different types-characteristics and performance	10
IV	Typical design methods –Ladder diagram- sequencing circuits design - combinational logic circuit design-cascade method – Karnaugh map method.	9
V	Electrical control of pneumatic and hydraulic circuits- use of relays, timers, counters ,interfacing with PLCs, proportional control of hydraulic systems	8

---

# SEMESTER VI

---

COURSE CODE	COURSE NAME	CATEGORY	L	T	P	CREDITS
22MET601	HEAT & MASS TRANSFER	ES	3	1	0	4

Preamble:

The objectives of the course are:

- To introduce the various modes of heat transfer and to develop methodologies for solving a wide variety of practical heat transfer problems
- To provide useful information concerning the performance and design of simple heat transfer systems
- Conceive the energy balance in any thermal practical situation involving heat transfer mechanisms.
- To introduce mass transfer.

Prerequisite: MET203 Mechanics of Fluids, MET202 Engineering Thermodynamics

Course Outcomes: After the completion of the course the student will be able to

CO 1	Apply principles of heat and mass transfer to engineering problems
CO 2	Analyse and obtain solutions to problems involving various modes of heat transfer
CO 3	Design heat transfer systems such as heat exchangers, fins, radiation shields etc.
CO 4	Define laminar and turbulent boundary layers and ability to formulate energy equation in flow systems.

Mapping of course outcomes with program outcomes

	PO 1	PO 2	PO 3	PO 4	PO 5	PO 6	PO 7	PO 8	PO 9	PO 10	PO 11	PO 12
CO 1	3	3	2									1
CO 2	3	3	3									2
CO 3	3	3	3									2
CO 4	3	3	3									2

Assessment Pattern

Bloom's Category	Continuous Assessment Tests		End Semester Examination
	1	2	
Remember	10	10	10
Understand	20	10	20
Apply	10	20	50
Analyse	10	10	20
Evaluate			
Create			

## Mark distribution

Total Marks	CIE	ESE	ESE Duration
150	50	100	3 hours

### Continuous Internal Evaluation Pattern:

Attendance	: 10marks
Continuous Assessment Test(2numbers)	: 25 marks
Assignment/Quiz/Course project	: 15marks

End Semester Examination Pattern: There will be two parts; Part A and Part B. Part A contain 10 questions with 2 questions from each module, having 3 marks for each question. Students should answer all questions. Part B contains 2 questions from each module of which student should answer any one. Each question can have maximum 2 sub-divisions and carry 14 marks.

## Course Level Assessment Questions

### Course Outcome 1 (CO1):

1. A furnace wall is made up of three layers of thicknesses 250 mm, 100 mm and 150 mm with thermal conductivities of 1.65 W/m.K and 9.2 W/m.K respectively. The inside is exposed to gases at 1250 °C with a convection coefficient of 25 W/m<sup>2</sup>.K. and the inside surface is at 1100 °C, the outside surface is exposed to air at 25 °C with convection coefficient of 12 W/m<sup>2</sup>.K. Determine (a) the unknown thermal conductivity K (b) the overall heat transfer coefficient (c) all the intermediate temperatures?
2. Derive an expression for steady state temperature distribution in a slab with internal heat generation.
3. Dry air at 300 °C and 1 atm flows over a wet flat plate 600 mm. long at a velocity of 50 m/s. Calculate the mass transfer co-efficient of water vapour in air at the end of the plate. Take the diffusion co-efficient of water vapour in air,  $D = 0.26 \times 10^{-4} \text{ m}^2/\text{s}$ .

### Course Outcome 2 (CO2)

1. Discuss the importance of non-dimensional numbers in heat transfer problems.
2. A hollow sphere ( $k = 65 \text{ W/m.K}$ ) of 120 mm inner diameter and 350 mm outer diameter is covered 10 mm layer of insulation ( $k = 10 \text{ W/m.K}$ ). The inside and outside temperatures are 500 °C and 50 °C respectively. Calculate the rate of heat flow through this sphere.

3. A steel ball (specific heat = 0.46 kJ/kg.K, and thermal conductivity 35W/m.K) having 5 cm diameter and initially at a uniform temperature of 450 °C is suddenly placed in a control environment in which the temperature is maintained at 100 °C. Calculate the time required for the ball to attain a temperature of 150 °C.

Course Outcome 3(CO3):

1. Water at the rate of 4 kg/s is heated from 40 °C to 55°C in a shell and tube heat exchanger. On the shell side one pass is used with water as the heating fluid and at a mass flow rate of 2 kg/s, and entering the heat exchanger at 95 °C. The overall heat transfer coefficient is 1500 W/m<sup>2</sup>K. and the average water velocity in the 2 cm diameter tubes is 0.5 m/s. Because of space limitations, the tube length must not exceed 3 m. Calculate the number of tube passes, the number of tubes per pass and the length of the tubes, keeping in mind the design constraints.
2. Two large plates, one at 800 K and other at 600 K have emissivities 0.5 and 0.8 respectively. A radiation shield having an emissivity 0.1 on one side and emissivity 0.05 on the other side is placed between the plates. Calculate the heat transfer by radiation per square meter with and without the radiation shield.
3. A rectangular aluminum fin of thermal conductivity 200 W/m.K, 3mm. thick and 7.5 cm long protrudes out from a wall. The fin base is maintained at a temperature of 300 °C and the ambient temperature is 50 °C with heat transfer coefficient 10W/m<sup>2</sup>K. The tip of the fin is insulated. Calculate the heat transfer from the fin per unit depth of material.

Course Outcome 4 (CO4):

1. Explain velocity boundary layer and thermal boundary layer with neat sketches.
2. Air at 40 °C flows over a tube with a velocity of 30 m/s. The tube surface temperature is 120 °C. Calculate the heat transfer coefficient for the following cases:
  - (i) Tube is square with a side of 6 cm
  - (ii) Tube is circular cylinder with a diameter of 6 cm.
3. Air at 20 °C at atmospheric pressure flows over a flat plate at a velocity of 3 m/s. If the plate is 1 m wide and at 80 °C, calculate the following at  $x = 300\text{mm}$ .
  - i. Hydrodynamic boundary layer thickness
  - ii. Thermal boundary layer thickness
  - iii. Local friction coefficient
  - iv. Average heat transfer coefficient
  - v. Heat transfer rate

MODEL QUESTION PAPER  
SIXTH SEMESTER MECHANICAL ENGINEERING

Heat and Mass Transfer-MET302

Maximum: 100 Marks

Duration: 3 hours

PART A

Answer all questions. Each question carries 3 marks

1. Discuss about the application of Heisler chart and Schmidt plot in heat transfer analysis.
2. How does a numerical solution method differ from analytical one? Explain.
3. What are the characteristics of a boundary layer?
4. Write the significance of Nusselt number.
5. What is meant by condensation heat transfer? How it differs from drop wise heat transfer?
6. What are the main factors to be considered for a heat exchanger design?
7. Explain about radiation shape factor.
8. What are the properties of blackbody?
9. Give two examples of mass transfer in day-to-day life.
10. Explain Ficks law of diffusion with suitable assumptions.

(10 X 3 = 30 Marks)



## PART B

Answer one full question from each module

### MODULE 1

11.

a) Derive 3-dimensional unsteady state heat conduction equation with heat generation, in Cartesian co-ordinate system for anisotropic material. (7Marks)

b) A 3 mm diameter and 5m long electric wire is tightly wrapped with a 2 mm thick plastic cover whose thermal conductivity is  $k = 0.15 \text{ W/m-K}$ . Electrical measurements indicate that a current of 10 A passes through the wire and there is a voltage drop of 8 V along the wire. If the insulated wire is exposed to a medium at  $T_\infty = 30^\circ\text{C}$  with a heat transfer coefficient of  $h = 12 \text{ W/m}^2\text{-K}$ , determine the temperature at the interface of the wire and the plastic cover in steady operation. Also state with reason, whether doubling the thickness of the plastic cover will increase or decrease heat transfer.

(7 Marks)

12.

a) Derive an expression for temperature distribution for 1-dimensional slab with varying thermal conductivity. Assume the variation of thermal conductivity of slab as  $k = k_0(1+\beta t)$ .

(7 Marks)

b) A square plate heater 15 cm x 15 cm is inserted between two slabs. Slab A is 2 cm thick ( $k = 50\text{W/m-K}$ ) and Slab B is 1cm thick ( $k = 0.2\text{W/m-K}$ ). The outside heat transfer coefficients on side A and side B are  $200\text{W/m}^2\text{-K}$  and  $50\text{W/m}^2\text{-K}$  respectively. The temperature of surrounding air is  $25^\circ\text{C}$ . If rating of heater is 1 KW, find (a) Maximum temperature in the system, and (b) outer surface temperature of the two slabs. (7Marks)

### MODULE II

13.

a) Saturated propane at 300 K with a velocity of 25 cm/s flows over a flat plate of length  $L=2 \text{ m}$ . and width  $w=1 \text{ m}$ . maintained at uniform temperature of 400 K. Calculate the local heat transfer coefficient at 1 m. length and the average heat transfer coefficient from  $L=0 \text{ m}$ . to  $L=2 \text{ m}$ . Also find the heat transfer. (7Marks)

b) Hot air at atmospheric pressure and  $80^\circ\text{C}$  enters an 8 m. long uninsulated square duct of cross section  $0.2 \text{ m.} \times 0.2 \text{ m.}$  that passes through the attic of a house at a rate of  $0.15\text{m}^3/\text{s}$ . The duct is observed to be nearly isothermal at  $60^\circ\text{C}$ . Determine the exit temperature of the air. (7Marks)

14.

a) Air at  $15^{\circ}\text{C}$ ,  $35\text{ m/s}$ , flows through a hollow cylinder of  $4\text{ cm}$  inner diameter and  $6\text{ cm}$  outer diameter and leaves at  $45^{\circ}\text{C}$ . The tube passes through a room where the room temperature is  $65^{\circ}\text{C}$  and tube wall is maintained at  $60^{\circ}\text{C}$ . Calculate the heat transfer coefficient between the air and the inner tube. (7Marks)

b) Consider a  $0.6\text{ m} \times 0.6\text{ m}$  thin square plate in a room at  $30^{\circ}\text{C}$ . One side of the plate is maintained at a temperature of  $90^{\circ}\text{C}$ , while the other side is insulated. Determine the rate of heat transfer from the plate by natural convection. If the emissivity of the surface is  $1.0$ , calculate the heat loss by radiation. Also calculate the percentage of heat loss by convection. (7Marks)

### MODULE III

15.

a) A counter flow double pipe heat exchanger is to heat water from  $20^{\circ}\text{C}$  to  $80^{\circ}\text{C}$  at a rate of  $1.2\text{ kg/s}$ . The heating is to be accomplished by geothermal water available at  $170^{\circ}\text{C}$  at a mass flow rate of  $2\text{ kg/s}$ . The inner tube is thin walled and has a diameter of  $1.5\text{ cm}$ . If the overall heat transfer coefficient of the heat exchanger is  $640\text{ W/m}^2\text{-K}$ , determine the length of the heat exchanger required to achieve the desired heating. Use  $\epsilon\text{-NTU}$  method.

(8 Marks)

b) Derive an expression for LMTD of double pipe, parallel flow heat exchanger.

(6 Marks)

16.

a) Steam in the condenser of a power plant is to be condensed at a temperature of  $30^{\circ}\text{C}$  with cooling water from a nearby lake, which enters the tubes of the condenser at  $14^{\circ}\text{C}$  and leaves at  $22^{\circ}\text{C}$ . The surface area of the tubes is  $45\text{ m}^2$  and the overall heat transfer coefficient is  $2100\text{ W/m}^2 \cdot ^{\circ}\text{C}$ . Determine the mass flow rate of the cooling water needed and the rate of condensation of the steam in the condenser. (7Marks)

b) In a double pipe heat exchanger, hot fluid with a specific heat of  $2300\text{ J/kg}$  enters at  $380^{\circ}\text{C}$  and leaves at  $300^{\circ}\text{C}$ . Cold fluid enters at  $25^{\circ}\text{C}$  and leaves at  $210^{\circ}\text{C}$ . Calculate the heat exchanger area required for (i) Counter flow and (ii) Parallel flow. Take overall heat transfer coefficient as  $750\text{ W/m}^2\text{ K}$  and mass flow rate of hot fluid is  $1\text{ kg/s}$ . (7Marks)

## MODULE IV

17.

a) A 70 mm. thick metal plate with a circular hole of 35 mm. diameter along the thickness is maintained at a uniform temperature 250 °C. Find the loss of energy to the surroundings at 27 °C, assuming the two ends of the hole to be as parallel discs and the metallic surfaces and surroundings have blackbody characteristics. (6Marks)

b) Two large parallel planes with emissivities of 0.3 and 0.5 are maintained at temperatures of 527 °C and 127 °C respectively. A radiation shield having emissivities of 0.05 on both sides is placed between them. Calculate,

(i) Heat transfer rate between them without shield.

(ii) Heat transfer rate between them with shield.

(8 Marks)

18.

a) Two parallel plates of size 1.0 m. by 1.0 m. spaced 0.5 m apart are located in a very large room, the walls of which are maintained at a temperature of 27°C. One plate is maintained at a temperature of 900 °C and the other at 400 °C. Their emissivities are 0.2 and 0.5 respectively. If the plates exchange heat between themselves and the surroundings, find the net heat transfer to each plate and to the room. Consider only the plate surface facing each other.

(8 Marks)

b) Two rectangular surfaces are perpendicular to each other with a common edge of 2 m. The horizontal plane is 2 m. long and vertical plane is 3 m long. Vertical plane is at 1200 K and has an emissivity of 0.4. the horizontal plane is 18 °C and has an emissivity of 0.3. Determine the net heat exchange between the planes. ( 6 marks)

## MODULE V

19.

a) Explain the analogy between heat and mass transfer.

(6 Marks)

b) Dry air at 30°C and 1 atm flows over a wet flat plate 600 mm. long at a velocity of 50 m/s. Calculate the mass transfer co-efficient of water vapour in air at the end of the plate. Take the diffusion co-efficient of water vapour in air,  $D = 0.26 \times 10^{-4} \text{ m}^2/\text{s}$ .

(8Marks)

20.

a) Gaseous hydrogen is stored at elevated pressure in a rectangular steel container of 10 mm. wall thickness. The molar concentration of hydrogen in steel at the inner surface is  $2 \text{ kg mol/m}^3$ , while the concentration of hydrogen in steel at the outer surface is  $0.5 \text{ kg mol/m}^3$ . The binary diffusion coefficient for hydrogen in steel is  $0.26 \times 10^{-12} \text{ m}^2/\text{s}$ . What is the mass flux of hydrogen through the steel? (8 Marks)

b) Explain the phenomenon of equimolar counter diffusion. Derive an expression for equimolar counter diffusion between two gases or liquids.

(6 Marks)

## Syllabus

### Module 1-

#### CONDUCTION HEAT TRANSFER

Introduction to heat transfer- thermodynamics and heat transfer-typical heat transfer situations- modes of heat transfer- mechanism of heat transfer- basic laws of heat transfer- thermal conductivity-effect of temperature on thermal conductivity- combined heat transfer mechanism-real life situations of combined heat transfer.

Differential equations of heat conduction-boundary conditions and initial conditions, one dimensional steady state situations – plane wall, cylinder, sphere -concept of thermal resistance, critical radius, conduction with heat generation- Two-dimensional steady state situations, transient conduction, Lumped capacitance model, concept of Heisler chart and Schmidt Plot-Conduction shape factor-Numerical methods of analysis-thermal analysis of rectangular fins.

### Module 2

#### CONVECTION HEAT TRANSFER

Fundamentals, order of magnitude analysis of momentum and energy equations; hydrodynamic and thermal boundary Layers-Relation between fluid friction and heat transfer-Concepts of fluid mechanics, Differential equation of heat convection, Laminar flow heat transfer in circular pipe – constant heat flux and constant wall temperature, thermal entrance region, Turbulent flow heat transfer in circular pipe, pipes of other cross sections, Heat transfer in laminar flow and turbulent flow over a flat plate, Reynolds analogy, Flow across a cylinder and sphere- Natural convection- basics-free convection heat transfer on a vertical flat plate-empirical relations for free convection heat transfer.

### Module 3

#### HEAT EXCHANGERS

Condensation heat transfer phenomena- the condensation Number-Boiling heat transfer Phenomena-Simplified relations for boiling heat transfer-Introduction to heat exchangers-types of heat exchangers-the overall heat transfer coefficient-Fouling factor-LMTD analysis of heat exchangers-effectiveness-NTU method-Analysis of variable properties-compact heat exchangers-heat exchanger design considerations.

## Module 4

### RADIATION HEAT TRANSFER

Physical mechanism of radiation heat transfer-Radiation properties-; Black body radiation Planck's law, Wein's displacement law, Stefan Boltzmann law, Kirchoff's law; Gray body Radiation shape factors-heat exchange between non -black bodies-Infinite parallel planes-Radiation combined with conduction and convection.

## Module 5

### MASS TRANSFER

Introduction to mass transfer- Molecular diffusion in fluids- Steady state molecular diffusion in fluids under stagnant and laminar flow conditions - Fick's law of diffusion-Types of solid diffusion- mass transfer coefficients in laminar and turbulent flows- Introduction to mass transfer coefficient- Equimolar counter-diffusion- Correlation for convective mass transfer coefficient- Correlation of mass transfer coefficients for single cylinder- Theories of mass transfer- Overall mass transfer coefficients.

### Text Books

1. Sachdeva R.C., Fundamentals of Engineering Heat and Mass Transfer, New Age Science Limited, 2009
2. R.K.Rajput. Heat and mass transfer, S.Chand &Co., 2015
3. Nag P.K., Heat and Mass Transfer, McGrawHill, 2011
4. Kothandaraman C.P., Fundamentals of Heat and Mass Transfer, New Age International, New Delhi,2006

### Data Book

Heat and Mass Transfer data book: C.P. Kothandaraman, S. Subramanya, New age International Publishers,2014

### Reference Books

2. Holman J.P, "Heat transfer", Mc Graw-Hill, 10th. Ed.,2009.
3. Yunus A. Cengel, "Heat and Mass Transfer: Fundamentals and Applications" McGraw-Hill Higher Education; 6th edition,2019.
4. Frank P. Incropera and David P. Dewitt, Heat and Mass Transfer, John Wiley and sons,2011

## COURSE PLAN

MODULE	TOPICS	HOURS ALLOTTED
1	Introduction to heat transfer- thermodynamics and heat transfer- typical heat transfer situations- modes of heat transfer- mechanism of heat transfer- basic laws of heat transfer- thermal conductivity- thermal conductivity-effect of temperature on thermal conductivity- combined heat transfer mechanism-real life situations of combined heat transfer.	2-0-0
	Differential equations of heat conduction-boundary conditions and initial conditions, one dimensional steady state situations – plane wall, cylinder, sphere -concept of thermal resistance, critical radius, conduction with heat generation- Two-dimensional steady state situations, transient conduction, Lumped capacitance model, concept of Heisler chart and Schmidt Plot-Conduction shape factor-Numerical methods of analysis- thermal analysis of rectangular fins.	6-4-0
2	Fundamentals, order of magnitude analysis of momentum and energy equations; hydrodynamic and thermal boundary Layers-Relation between fluid friction and heat transfer-Concepts of fluid mechanics, Differential equation of heat convection, Laminar flow heat transfer in circular pipe – constant heat flux and constant wall temperature, thermal entrance region, Turbulent flow heat transfer in circular pipe, pipes of other cross sections, Heat transfer in laminar flow and turbulent flow over a flat plate, Reynolds analogy, Flow across a cylinder and sphere- Natural convection- basics- free convection heat transfer on a vertical flat plate- empirical relations for free convection heat transfer.	6-4-0
3	Condensation heat transfer phenomena- the condensation Number-Boiling heat transfer Phenomena-Simplified relations for boiling heat transfer-Introduction to heat exchangers-types of heat exchangers-the overall heat transfer coefficient-Fouling factor-LMTD analysis of heat exchangers-effectiveness-NTU method-Analysis of variable properties- compact heat exchangers-heat exchanger design considerations.	5-2-0
4	Physical mechanism of radiation heat transfer-Radiation properties-; Black body radiation Planck's law, Wein's displacement law, Stefan Boltzmann law, Kirchoff's law; Gray body Radiation shape factors-heat exchange between non -black bodies-Infinite parallel planes-Radiation combined with conduction and convection.	5-2-0

5	Introduction to mass transfer- Molecular diffusion in fluids- Steady state molecular diffusion in fluids under stagnant and laminar flow conditions - Fick's law of diffusion-Types of solid diffusion- mass transfer coefficients in laminar and turbulent flows- Introduction to mass transfer coefficient- Equimolar counter-diffusion- Correlation for convective mass transfer coefficient- Correlation of mass transfer coefficients for single cylinder- Theories of mass transfer- Overall mass transfer coefficients	7-2-0
---	---	-------

COURSE CODE	COURSE NAME	CATEGORY	L	T	P	CREDITS
22MET602	DYNAMICS AND DESIGN OF MACHINERY	ES	3	1	0	4

Preamble: This course focuses on important topics of dynamics of machinery and design of machine elements. It covers the topics namely force of four bar mechanisms, design of flywheels, welded joints, riveted joints and spring. Design of machine elements due to impact, shock and fatigue loading are covered in the syllabus. Analysis of free and forced vibration of single degree of freedom systems and a brief introduction about free vibration of two degree of freedom systems is also included.

Prerequisite: EST100 Engineering Mechanics

Course Outcomes: After the completion of the course the student will be able to:

CO 1	Do engine force analysis and to draw turning moment diagrams
CO 2	Analyse free and forced vibrations of single degree of freedom systems
CO 3	Determine the natural frequencies of a two degree of freedom vibrating system and to calculate the stresses in a structural member due to combined loading
CO 4	Design machine elements subjected to fatigue loading and riveted joints
CO 5	Design welded joint and close coiled helical compression spring

Mapping of course outcomes with program outcomes

	PO 1	PO 2	PO 3	PO 4	PO 5	PO 6	PO 7	PO 8	PO 9	PO 10	PO 11	PO 12
CO 1	3	3	2									
CO 2	3	3	2									
CO 3	3	3	2									
CO 4	3	3	2									
CO 5	3	3	2									

Assessment Pattern

Bloom's Category	Continuous Assessment Tests		End Semester Examination
	1	2	
Remember	10	10	10
Understand	20	20	20
Apply	20	20	70
Analyse			
Evaluate			
Create			

Mark distribution

Total Marks	CIE	ESE	ESE Duration
150	50	100	3 hours



### Continuous Internal Evaluation Pattern:

Attendance	: 10 marks
Continuous Assessment Test (2 numbers)	: 25 marks
Assignment/Quiz/Course project	: 15 marks

End Semester Examination Pattern: There will be two parts; Part A and Part B. Part A contain 10 questions with 2 questions from each module, having 3 marks for each question. Students should answer all questions. Part B contains 2 questions from each module of which student should answer any one. Each question can have maximum 2 sub-divisions and carry 14 marks.

### Course Level Assessment Questions

#### Course Outcome 1 (CO1):

1. Explain D' Alembert's principle.
2. Determine analytically the forces such as piston effort, force in the connecting rod and side thrust on the cylinder walls of a reciprocating engine.
3. Draw the turning moment diagram of IC engine.
4. Derive an expression for the coefficient of fluctuation of energy.
5. Derive an expression relating the stress in a flywheel and its linear speed.

#### Course Outcome 2 (CO2)

1. Explain the energy method and Newton's method to determine the natural frequencies of a single degree of freedom system.
2. Derive an expression for the logarithmic decrement.
3. Find the forced response of a damped single degree of freedom vibrating system subjected to a harmonic excitation.
4. Distinguish between motion transmissibility and force transmissibility.
5. What is whirling? Derive an expression for the critical speed of a shaft.

#### Course Outcome 3 (CO3):

1. Find the natural frequencies and mode shapes of a two degree freedom vibrating system.
2. What do you mean by eigenvalues and eigenvectors of a multi degree freedom vibrating system?
3. What are the steps in the design process?
4. Define stress concentration factor. How can we minimize it?

#### Course Outcome 4 (CO4):

1. Explain Goodman's criterion.

2. Explain Soderberg's criterion.
3. Define endurance limit and factor of safety.
4. Derive an expression for the impact stress due to a freely falling body.
5. Describe the modes of failure of a riveted joint.
6. What are the different efficiencies of a riveted joint?
7. Classify the riveted joints.

Course Outcome 5 (CO5):

1. What are the different types of welded joint?
2. Describe AWS welding symbols with neat sketches.
3. Determine the weld size of a joint subjected to axial, bending and twisting loads.
4. Derive an expression for the shear stress in the spring wire.
5. Derive an expression for the deflection of a helical compression spring.
6. Why concentric springs are required in certain applications?

### MODEL QUESTION PAPER

APJ ABDUL KALAM TECHNOLOGICAL UNIVERSITY

VI SEMESTER BTECH DEGREE EXAMINATION

MET304 : DYNAMICS AND DESIGN OF MACHINERY

Maximum: 100 Marks

Duration:3 hours

*Use of Machine Design Data Book is permitted.*

### PART A

Answer all questions, each question carries 3 marks

1. Describe briefly the dynamic force analysis of a reciprocating engine.
2. Derive an expression for the coefficient of fluctuation of energy.
3. Derive an expression for logarithmic decrement.
4. Define whirling speed of a shaft.
5. Explain the mode shapes of a vibrating system.
6. What are the steps in the design process?
7. Define endurance limit. What are the factors affecting it?
8. What are the failure modes of a riveted joint?

9. Describe the AWS welding symbols.

10. Explain i) surge ii) resilience and iii) curvature effect of a spring. (10×3=30 Marks)

## PART B

Answer one full question from each module

### MODULE 1

11. a) Describe with a neat sketch the turning moment diagram for a four-stroke internal combustion engine (4 marks)

b) The turning moment of an engine is given by the equation:  $2500 + 750 \sin 3\theta$  Nm where  $\theta$  is the crank angle in radians. The mean speed of the engine is 300 rpm. The flywheel along with other rotating parts attached to the engine have a mass of 500 kg at a radius of gyration of 0.8 m. Determine i) the power developed by the engine and ii) the percentage of fluctuation of speed of the flywheel (10 marks)

12. a) State and explain D' Alembert's principle. (4 marks)

b) The ratio of connecting rod length to crank length of a vertical gasoline engine is 4. The engine bore and stroke are 8 cm and 10 cm respectively. The mass of the reciprocating parts is 1 kg. The gas pressure on the piston is 6 bar, when it has moved  $40^\circ$  from the inner dead centre during the power stroke. Determine the following:

- i. Net load on the piston
- ii. Net load on the gudgeon pin and the crank pin
- iii. Thrust on the cylinder walls
- iv. Thrust on the crank bearing

The engine runs at 2000 rpm. At what engine speed will the net load on the gudgeon pin be zero? (10 marks)

### MODULE 2

13. a) A machine of mass 1000 kg is acted upon by an external force of 2450 N at a speed of 1500 rpm. To reduce the effect, vibration isolators made of rubber having a static deflection of 2 mm under the machine load and an estimated damping factor of 0.2 are used. Determine the following:

- i. Force transmitted to the foundation

- ii. Amplitude of vibration of machine
- iii. Phase lag between the transmitted force and the displacement of mass. (9 marks)

b) Distinguish between motion transmissibility and displacement transmissibility. (5 marks)

14.a) A damped spring mass system has mass 3 kg, stiffness 100 N/m and damping coefficient 3 Ns/m. Determine the following:

- i. Damping ratio
- ii. Damped natural frequency
- iii. Logarithmic decrement
- iv. Ratio of two successive amplitudes (8 marks)

b) Describe briefly Newton's method and energy method used for obtaining the natural frequencies. (6 marks)

### MODULE 3

15. Find the natural frequencies and mode shapes of a two degree freedom system shown in figure. The masses are  $m_1 = m_2 = 10$  kg and the stiffness values are  $k_1 = k_2 = 2$  kN/mm.

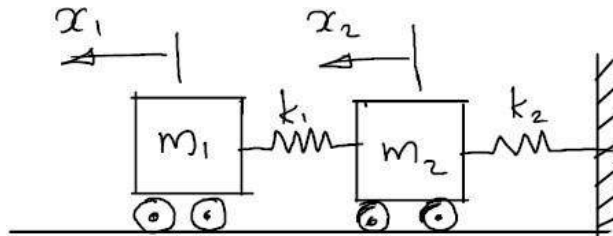

16.a) Define stress concentration factor. How can it be minimized? (5 marks)

b) Calculate the stress at point A on the fixed end of a rod of length 80 mm and cross-sectional area  $30 \text{ mm}^2$  shown in figure. (9 marks)

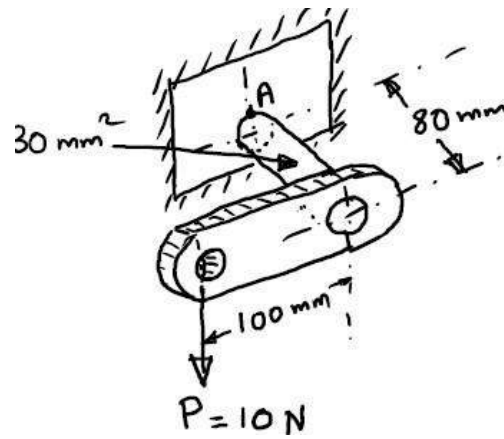

#### MODULE 4

17. a) Distinguish between Soderberg and Goodman criteria. (5 marks)
- b) A round bar is subjected to the following variable loads. Torque varying from 2kNm to 5 kNm, bending moment varying from 10 kNm to 12 kNm. Calculate the size of the bar if it is made of C40 steel with yield stress of 324 MPa. Yield stress in shear is 50% of that in uniaxial loading. Adopt a factor of safety of 2.5 on yield stress for shear. (9 marks)
18. a) What are the advantages of riveted joint over welded joint? (4 marks)
- b) Design a double riveted butt joint with equal widths of cover plates to join two plates of thickness 10 mm. The allowable stress for the material of the rivets and for the plates are as follows: For plate material in tension,  $\sigma_t = 80$  MPa, for rivet material in compression,  $\sigma_c = 120$  MPa, for rivet material in shear,  $\tau = 60$  MPa (10 marks)

#### MODULE 5

19. a) Describe with neat sketches the different types of welded joints. (5 marks)
- b) An eccentrically loaded bracket is welded to a support as shown in figure. The permissible shear stress for the weld material is 80 MPa. Determine the size of the weld. (9 marks)

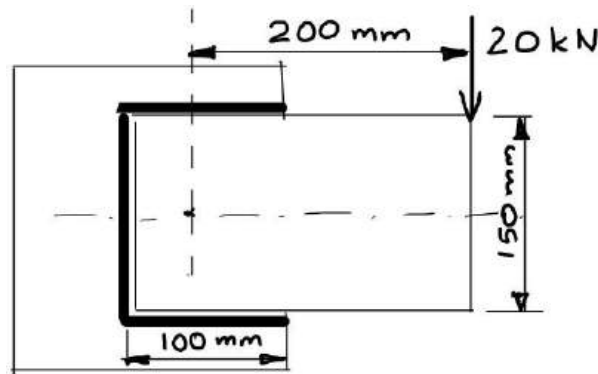

20. a) Derive an expression for the axial deflection of a close coiled helical spring.

(5 marks)

b) A bumper consisting of two helical springs of circular section, brings to rest a railway wagon of mass 1500 kg moving at 1.2 m/s. While doing so, the springs are compressed by 150 mm. The mean diameter of the coil is 6 times the wire diameter. The permissible shear stress is 400 MPa. Determine i) the maximum force on each spring ii) wire diameter of the spring, iii) mean diameter of the coils and iv) the number of active coils. Take  $G=0.84 \times 10^6$  MPa.

(9 marks)

## Syllabus

### Module 1

Dynamic force analysis- D' Alembert's principle –four bar mechanism- engine force analysis (reciprocating engines)- piston side thrust-connecting rod force-piston effort- dynamic force analysis considering mass of the connecting rod-analytical method.

Flywheels-turning moment diagrams for four stroke internal combustion engine and multi cylinder engines-coefficient of fluctuation of speed-coefficient of fluctuation of energy-design of flywheels.

### Module 2

Introduction- free vibration of single degree undamped systems- natural frequency-energy method- Newton's second law (free body diagram)-damped systems- logarithmic decrement.

Forced vibration-single degree of freedom systems-harmonic excitation-vibration isolation-transmissibility-whirling of shafts.

### Module 3

Introduction to two degree of freedom systems- natural frequencies and mode shapes.

Introduction to design-definition, steps in the design process, materials and their properties-elastic and plastic behaviour of metals, ductile and brittle behaviour, shear, bending and torsional stresses, combined stresses, stress concentration factor.

## Module 4

Shock and impact loads- fatigue loading- Gerber, Goodman and Soderberg criteria, endurance limit stress, factors affecting endurance limit, factor of safety.

Design of riveted joints- material for rivets, modes of failure, efficiency of joint, design of boiler and tank joints, structural joints.

## Module 5

Design of welded joints-welding symbols, stresses in fillet and butt welds, Butt joint in tension, fillet weld in tension, fillet joint under torsion, fillet weld under bending, eccentrically loaded welds.

Springs- classification, spring materials, stresses and deflection of helical springs, axial loading, curvature effect, resilience, static and fatigue loading, surge in spring, critical frequency, concentric springs, end construction.

## Text Books

1. Ballaney, P. L. Theory of machines and mechanisms. Khanna Publishers, 2010.
2. Rattan S S, Theory of Machines, Tata McGraw-Hill Education, 2005.
3. Bhandari V B, Design of Machine Elements, Tata McGraw-Hill Education, 2010.

## Design Data Books (permitted for reference in the university examination)

1. Mahadevan, K., and K. Balaveera Reddy. Design Data Handbook; Mechanical Engineers in SI and Metric Units. CBS Publishers & Distributors, New Delhi, 2018.
2. NarayanaIyengar B.R & Lingaiah K, Machine Design Data Handbook, Tata McGraw Hill/Suma Publications, 1984
3. PSG Design Data, DPV Printers, Coimbatore, 2012

## Reference Books

1. Charles E Wilson and J Peter Sadler, Kinematics and Dynamics of Machinery, Tata McGraw-Hill Education, 2008.
2. Amithabha Ghosh and Asok Kumar Malik, Theory of Mechanisms and Machines, East West Press, 2011
3. Robert L Norton, Design of Machinery, Tata Mc Graw-Hill, 2005
4. P C Sharma and D K Aggarwal, Machine Design, S K Kataria & Sons

## Course Contents and Lecture Schedule

No	Topic	No. of Lectures
1		
1.1	Dynamic force analysis- D' Alembert's principle –Four bar mechanism-	3
1.2	Engine force analysis (reciprocating engines)- piston side thrust-connecting rod force-piston effort- dynamic force analysis considering mass of the connecting rod-analytical method.	4
1.3	Flywheels, turning moment diagrams-four stroke internal combustion engines and multi cylinder engines	3
1.4	Coefficient of fluctuation of speed-coefficient of fluctuation of energy-design of flywheels	2
2		
2.1	Introduction- free vibration of single degree undamped systems- natural frequency-energy method- Newton's second law (free body diagram)-damped systems- logarithmic decrement.	3
2.2	Forced vibration-single degree of freedom systems-harmonic excitation-vibration isolation-transmissibility-whirling of shafts.	3
3		
3.1	Introduction to two degree of freedom systems- natural frequencies and mode shapes.	3
3.2	Introduction to design-definition, steps in design process. materials and their properties- elastic and plastic behaviour of metals, ductile and brittle behaviour	3
3.3	Shear, bending and torsional stresses, combined stresses, stress concentration factor.	4
4		
4.1	Shock and Impact loads, fatigue loading- Gerber, Goodman and Soderberg criteria, endurance limit stress, factors affecting endurance limit, factor of safety.	2
4.2	Design of riveted joints- material for rivets, modes of failure, efficiency of joint, design of boiler and tank joints, structural joints.	3
5		
5.1	Design of welded joints-welding symbols, stresses in fillet and butt welds, butt joint in tension, fillet weld in tension,	3
5.2	Fillet joint under torsion, fillet weld under bending, eccentrically loaded welds.	2
5.3	Springs- classification, spring materials, stresses and deflection of	3



	helical springs, axial loading, curvature effect, resilience, static and fatigue loading	
5.4	Surge in spring, critical frequency, concentric springs, end construction.	3

COURSE CODE	COURSE NAME	CATEGORY	L	T	P	CREDITS
22MET603	ADVANCED MANUFACTURING ENGINEERING	ES	3	1	0	4

**Preamble:**

1. Understand the capabilities, limitations of conventional manufacturing & machining process and what the need of advanced manufacturing processes is.
2. Understand, how to formulate tool path and program CNC machines.
3. Understand, how PLC operate and control automated equipment and systems.
4. Understand the need of atomic level surface roughness and machining process.
5. Understand the need of high velocity forming of metals.

Prerequisite: MET 205 Metallurgy and material science and MET204 Manufacturing Processes

Course Outcomes - At the end of the course students will be able to

CO 1	To be conversant with the advanced machining process and to appreciate the effect of process parameters on the surface integrity aspects during the advanced machining process.
CO 2	CNC programming, select appropriate tooling and fixtures.
CO 3	To categorize the various nontraditional material removal process based on energy sources and mechanism employed.
CO 4	Analyze the processes and evaluate the role of each process parameter during micro machining of various advanced material removal processes.
CO 5	Explain the processes used in additive manufacturing for a range of materials and applications.

Mapping of course outcomes with program outcomes (Minimum requirements)

	PO 1	PO 2	PO 3	PO 4	PO 5	PO 6	PO 7	PO 8	PO 9	PO 10	PO 11	PO 12
CO 1	3	-	-	-	2	-	-	-	-	-	-	2
CO 2	2	-	2	-	3	-	-	-	-	-	-	-
CO 3	2	-	-	-	2	-	-	-	-	-	-	2
CO 4	2	3	-	-	2	-	-	-	-	-	-	-
CO 5	2	-	-	3	2	-	-	-	-	-	2	-

### Assessment Pattern

Bloom's taxonomy	Continuous Assessment Tests		End Semester Examination (Marks)
	Test I (Marks)	Test II (Marks)	
Remember	25	25	25
Understand	15	15	15
Apply	30	25	30
Analyze	10	10	10
Evaluate	10	15	10
Create	10	10	10

Mark distribution			
Total Marks	CIE marks	ESE marks	ESE duration
150	50	100	3 Hours
Continuous Internal Evaluation (CIE) Pattern:			
Attendance			10 marks
Regular class work/tutorials/assignments/self-learning (Minimum 3 numbers)			15 marks
Continuous Assessment Test (Minimum 2 numbers)			25 marks
<p>End semester pattern: -There will be two parts; Part A and Part B. Part A contain 10 questions with 2 questions from each module, having 3 marks for each question. Students should answer all questions. Part B contains 2 questions from each module of which student should answer anyone. Each question can have maximum 2 sub-divisions and carry 14 marks.</p>			

## COURSE LEVEL ASSESSMENT QUESTIONS

Course Outcome 1 (CO1): - To be conversant with the advanced machining process and to appreciate the effect of process parameters on the surface integrity aspects during the advanced machining process.

1. How carbonyls are useful in powder metallurgy?
2. A simple integrator in which  $p$  is a constant is performed with a DDA integrator. Calculate the output  $\Delta z$  at the first 8 iterations. The DDA contains 3-bit register which are initially set  $p = 5$  and  $q = 0$ . If each iteration is executed in 1 ms, draw the accumulated output  $\Delta z$  versus time.
3. What are the process parameters affecting the performance of USM
4. Draw and explain the effect of high speed on stress strain relationship of mild steel and copper

Course Outcome 2 (CO2): CNC programming, select appropriate tooling and fixtures.

1. Draw relay ladder diagram for the following sequential operations. Start button pressed, table motor started, package moves to the position of the limit switch and stops. Auxiliary features required are emergency stop, red light to indicate stop condition and green light to indicate package moving condition. Draw input and output connection diagrams also.
2. Draw a PLC ladder logic diagram to get the reciprocating motion of a punching machine using following sequential operations. One of the two motors operates when power is supplied. Motor drives the punch to one side. When it completes the required movement in one direction, a limit switch detects the position of the punch. First motor is get deactivated. Second motor starts and moves the punch to the opposite direction. When it completes required movement in opposite direction, a second limit switch detects the position of the punch. Second motor is get deactivated and first motor is started again and the process continues so as to get a continuous reciprocating motion. Also draw the input and output diagrams.
3. A DDA contains 8 bit registers. The value of its  $p$  register is constant and  $P = 150$  and the clock frequency is 10240pps. Calculate the output frequency of DDA
4. Describe with sketch the working and construction of recirculating ball screw used in CNC machine tools.
5. Explain linear and circular interpolations used in turning. Draw a neat sketch of circular interpolation

Course Outcome 3 (CO3): To categorize the various nontraditional material removal process based on energy sources and mechanism employed.

1. How the amplitude and frequency of vibration effects on material removal rate in Ultra Sonic Machining
2. What are the functions of electrolyte in ECM? What are the properties to be considered while selecting electrolytes in ECM?
3. What are the process parameters affecting the performance of USM

4. Which are the factors affecting its MRR in IBM process.
5. Describe the mechanism of material removal in Ion beam machining

Course Outcome 4 (CO4): Analyze the processes and evaluate the role of each process parameter during micro machining of various advanced material removal processes.

1. What is magneto rheological lapping? What are its advantages over conventional lapping?
2. Ablation of metals with Ultra short laser pulses.
3. Explain different types of elastic body waves
4. Draw and explain the effect of high speed on stress strain relationship of mild steel and copper
5. Explain with a neat schematic the fundamental principle of material removal in an abrasive jet machining process. Plot the trend for the Material Removal Rate with Nozzle Tip Distance (NTD) and explain why it rises, plateaus and falls with increasing NTD.
6. What is meant by ductile regime machine?

Course Outcome 5 (CO5): Explain the processes used in additive manufacturing for a range of materials and applications.

1. What are the two materials that are most commonly used for doing rapid prototyping of parts
2. What are the major process parameters involved in LIGA process?
3. A new car is designed, incorporating new technology, suggest how rapid prototyping could be applied for the development of the product. what are the steps followed? Discuss the factors considered.

**MODEL QUESTION PAPER**  
**SIXTH SEMESTER MECHANICAL ENGINEERING**  
**MET 306 - ADVANCED MANUFACTURING ENGINEERING**

Maximum Marks: 100

Duration: 3 Hours

**Part – A**

Answer all questions, each question carries 3 marks

1. Explain the different stages of sintering process in Powder metallurgy
2. Differentiate the impregnation and infiltration process in Powder metallurgy
3. What are the different word address formats used in part programming?
4. Mention the purpose of miscellaneous functions in part programming. Write any 2 M –codes with their applications
5. Describe the mechanism of material removal in Ion beam machining
6. What are the functions and desirable properties of dielectric fluid in EDM?
7. Explain the two Techniques in Explosive forming process
8. Differentiate P wave and S wave in High Velocity Forming
9. Write a note on Elastic Emission Machining
10. Explain the LIGA and its application, what is the aspect ratio in LIGA.

**PART -B**

Answer one full question from each module.

**MODULE – 1**

11. a) Explain the need and comparison between traditional and non-traditional manufacturing processes. (7 marks).
12. Explain Merchant's theory with neat sketches. (14 marks).

**MODULE – 2**

Write a Manual Part Program for the given figure (14 marks).

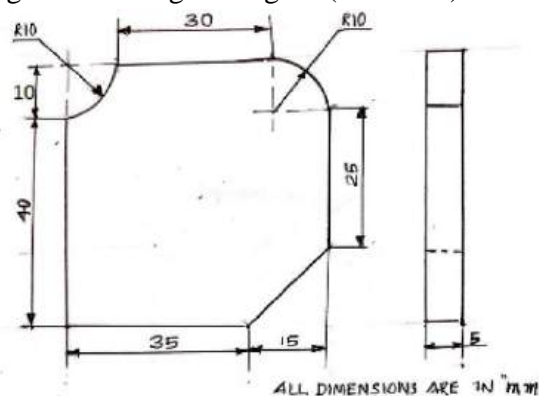

13. What is meant by interpolation in NC systems? Explain different types of interpolations. (14marks)

**MODULE – 3**

14. a) What are the parameters influencing the MRR in USM process (7 marks).  
b) How LBM differs from and EBM (7 marks).
15. Explain IBM with neat sketch; applications and vividly the process parameters influencing on it (14marks).
16. **MODULE – 4**  
a) Compare high velocity forming with conventional forming process (7 marks).  
b) What are stress waves? Write the equation for finding the velocity of shear wave (7 marks).
17. Explain Electro Magnetic Forming and show that it can be applied to internal, external and surface forming operations. (14 marks).
- MODULE – 5**
18. a.Explain the material removal mechanism in Diamond turn machining process (7 marks).  
b. With a neat sketch explain Diamond turn machining process. (7 marks).
19. . a. With a neat sketch explain Selective Laser Sintering.(7 marks).
20. b.Describe the Laminated Object Manufacturing Process (7 marks).

## SYLLABUS

### Module I

Powder Metallurgy- Powder Production- Powder characteristics- Mixing – Compaction: - techniques- sintering- Theory metal cutting - Orthogonal and oblique cutting- chip formation- Merchant's theory-Friction force - cutting tool materials -Thermal aspects of machining -Tool wear and wear mechanisms - Economics of machining- Machinability- Cutting fluids.

### Module II

Programmable Logic Controllers (PLC) – CNC: systems - contouring systems: principle of operation -DDA integrator: -Principle of operation, exponential deceleration –liner, circular and complete interpolator - NC part programming - Computer aided part programming - machining centers, feedback devices.

### Module III

Non Traditional machining processes: - EDM, USM, ECM, LBM, EBM, PAM, IBM, AJM, AWJM.

## Module IV

High velocity forming of metals - Sheet metal forming - explosive forming - Electro hydraulic forming - Electro Magnetic Forming.

## Module V

Micromachining: Diamond turn mechanism, Advanced finishing processes: - Abrasive Flow Machining, Magnetic Abrasive Finishing. - Magnetorheological Finishing, Magnetorheological Abrasive Flow Finishing, Magnetic Float Polishing, Elastic Emission Machining. - Material addition processes: - stereo-lithography, selective laser sintering, fused deposition modeling, laminated object manufacturing, laser engineered net-shaping, laser welding, LIGA process.

## Text Books

1. YoramKoren, Computer control of manufacturing systems, TMH
2. Jain V.K., Introduction to Micromachining, Narosa publishers.
3. Davies K and Austin E.R, Developments in high speed metal forming, the machinery publishing Co, 1970, SBN -853332053

## Reference

1. ASTME, High velocity forming of metals, PHI, 1968.
2. Ibrahim Zeid, R Sivasubrahmanian CAD/CAM: Theory & Practice Tata McGraw Hill Education Private Limited, Delhi.
3. .P.Groover, E.M. Zimmers, Jr."CAD/CAM"; Computer Aided Design and Manufacturing, Prentice Hall of India, 1987
4. PetruzellaFrank.D. - Programmable logic controllers
5. Jain V.K., Advanced Machining Processes
6. Armarego and Brown, The Machining of Metals, Prentice – Hall.
7. Paul. H. Black, Theory of Metal Cutting, McGraw Hill.
8. ASM hand book Volume 16, Machining, ASM international, 1989
9. Lal G.K., Introduction to Machining Science, New Age Publishers.



COURSE CONTENT AND LECTURE SCHEDULES.

Module	TOPIC	No.of hours	Course outcomes
1.1	Introduction: Need and comparison between traditional, non-traditional and micro & nano machining process.	2	CO1
	Powder Metallurgy: Need of P/M - Powder Production methods:- Atomization, electrolysis, Reduction of oxides, Carbonyls (Process parameters, characteristics of powder produced in each method).		
1.2	Powder characteristics: properties of fine powder, size, size distribution, shape, compressibility, purity etc.	2	CO1
	Mixing – Compaction:- techniques, pressure distribution, HIP & CIP(fundamentals to be explained in the class, self-learning topic , discretion of faculty)..		
1.3	Mechanism of sintering, driving force for pore shirking, solid and liquid phase sintering - Impregnation and Infiltration Advantages, disadvantages and specific applications of P/M.	1	
1.4	Theory metal cutting in turning: Tool nomenclature, attributes, surface roughness obtainable - Orthogonal and oblique cutting - Mechanism of metal removal - Mechanism of chip formation –chip breakers – Merchant’s theory.	3	CO1
1.5	Friction force laws in metal cutting - development of cutting tool materials (fundamentals to be explained in the class, self-learning topic, discretion of faculty).	1	CO1
1.6	Thermal aspects of machining -Tool wear and wear mechanisms - Economics of machining, Machinability, Cutting fluids(fundamentals to be explained in the class, self-learning topic, discretion of faculty).	1	CO1
2.1	Programmable Logic Controllers (PLC):need – relays - logic ladder program –timers, simple problems only.	1	CO1 CO2
2.2	Point to point, straight cut and contouring positioning - incremental and absolute systems – open loop and closed loop systems - control loops in contouring systems: principle of operation -DDA integrator:-Principle of operation, exponential deceleration –liner, circular and complete interpolator.	3	
2.3	NC part programming: part programming fundamentals - manual programming –NC coordinate systems and axes – tape format – sequence number, preparatory functions, dimension words, speed word, feed word, tool word, miscellaneous functions –	2	CO1 CO2
2.4	Computer aided part programming:- CNC languages – APT language structure.	3	CO1

	Programming exercises: simple problems on turning and drilling etc - <i>(At least one programming exercise must be included in the end semester University examination)</i> . - machining centers, feedback devices (fundamentals to be explained in the class, self-learning topic, discretion of faculty).		CO2
3.1	Non Traditional machining processes:- Electric Discharge Machining (EDM):- Mechanism of metal removal, dielectric fluid, spark generation, recast layer and attributes of process characteristics on MRR, accuracy, HAZ etc, Wire EDM, applications and accessories.	2	CO1 CO3
	Ultrasonic Machining (USM):-mechanics of cutting, effects of parameters on amplitude, frequency of vibration, grain diameter, slurry, tool material attributes and hardness of work material, applications.	2	CO1 CO3
3.2	Electro chemical machining (ECM):- Mechanism of metal removal attributes of process characteristics on MRR, accuracy, surface roughness etc, application and limitations.	1	CO1 CO3
3.3	Laser Beam Machining (LBM), Electron Beam Machining (EBM), Plasma arc Machining (PAM), Ion beam Machining(IBM) - Mechanism of metal removal, attributes of process characteristics on MRR, accuracy etc and structure of HAZ compared with conventional process; application, comparative study of advantages and limitations of each process.	3	CO1 CO3
3.4	Abrasive Jet Machining (AJM), Abrasive Water Jet Machining (AWJM) - Working principle, Mechanism of metal removal, Influence of process parameters, Applications, Advantages & disadvantages.	1	CO1 CO3
4.1	High velocity forming of metals:-effects of high speeds on the stress strain relationship steel, aluminum, Copper – comparison of conventional and high velocity forming methods- deformation velocity, material behavior, stain distribution.	2	CO1 CO3
4.2	Stress waves and deformation in solids – types of elastic body waves- relation at free boundaries- relative particle velocity.	2	CO1 CO3
4.3	Sheet metal forming: - explosive forming:-process variable,properties of explosively formed parts, etc.	2	CO1 CO3
4.4	Electro hydraulic forming: - theory, process variables, etc, comparison with explosive forming -Electro Magnetic Forming.	2	CO1 CO3
5.1	Micromachining: Diamond turn mechanism, material removal mechanism, applications.- Advanced finishing processes: - Abrasive Flow Machining, Magnetic Abrasive Finishing.	3	CO1 CO4
5.2	Magnetorheological Finishing, Magnetorheological Abrasive Flow Finishing, Magnetic Float Polishing, Elastic Emission Machining.	3	CO4
5.3	Material addition process:- stereo-lithography, selective laser sintering, fused deposition modeling, laminated object manufacturing, laser engineered net-shaping, laser welding, LIGA process.	3	CO5

COURSE CODE	COURSE NAME	CATEGORY	L	T	P	CREDITS
22MEE604.1	NON-DESTRUCTIVE TESTING	PROGRAM ELECTIVE 1	2	1	0	3

**Preamble:**

Nondestructive Testing (NDT) plays an extremely important role in quality control, flaw detection and structural health monitoring covering a wide range of industries. There are varieties of NDT techniques in use. This course will first cover the fundamental science behind the commonly used NDT methods to build the basic understanding on the underlying principles. It will then go on to cover the process details of each of these NDT methods.

Prerequisite: NIL

Course Outcomes: After the completion of the course the student will be able to

CO 1	Have a basic knowledge of surface NDT which enables to carry out various inspections in accordance with the established procedures.
CO 2	The students will be able to differentiate various defect types and select the appropriate NDT methods for the specimen.
CO 3	Calibrate the instrument and evaluate the component for imperfections.
CO 4	Have a basic knowledge of ultrasonic testing which enables them to perform inspection of samples.
CO 5	Have a complete theoretical and practical understanding of the radiographic testing, interpretation and evaluation.

**Mapping of course outcomes with program outcomes**

	PO 1	PO 2	PO 3	PO 4	PO 5	PO 6	PO 7	PO 8	PO 9	PO 10	PO 11	PO 12
CO 1	3	3	2									1
CO 2	3	3	2									1
CO 3	3	3	1									2
CO 4	3	3	2									2
CO 5	3	3	1									1

**Assessment Pattern**

Bloom's Category	Continuous Assessment Tests		End Semester Examination
	1	2	
Remember	25	25	25
Understand	25	25	25
Apply	30	30	30
Analyse	10	10	10
Evaluate	10	10	10
Create			

## Mark distribution

Total Marks	CIE	ESE	ESE Duration
150	50	100	3 hours

### Continuous Internal Evaluation Pattern:

Attendance : 10 marks

Continuous Assessment Test (2 numbers) : 25 marks

Assignment/Quiz/Course project : 15 marks

End Semester Examination Pattern: There will be two parts; Part A and Part B. Part A contain 10 questions with 2 questions from each module, having 3 marks for each question. Students should answer all questions. Part B contains 2 questions from each module of which student should answer any one. Each question can have maximum 2 sub-divisions and carry 14 marks.

### Course Level Assessment Questions

#### Course Outcome 1 (CO1):

1. Explain why NDT methods were initially developed
2. Describe the uses of NDT
3. Define the functionality of Destructive method

#### Course Outcome 2 (CO2)

1. Name the various nondestructive test methods
2. Recognize the NDT method abbreviations
3. Briefly explain each NDT method

#### Course Outcome 3(CO3):

1. Explain the discontinuities inherent in various manufacturing processes
2. Define the causes, prevention, and repair of those welding discontinuities
3. Explain the discontinuities inherent in various welding processes

#### Course Outcome 4 (CO4):

1. Explain basic principle of Radiographic examination.
2. Discuss principle of radiographic testing and give its application and limitation

3. Explain the principle, application and disadvantages of Radiographic Testing.

Course Outcome 5 (CO5):

1. Describe the various types of RT equipment
2. Describe the basic principles of gamma and X-ray generation
3. Name the three means of protection to help reduce exposure to radiation

MODEL QUESTION PAPER  
SIXTH SEMESTER MECHANICAL ENGINEERING  
NON DESTRUCTIVE TESTING - MET 312

Max. Marks : 100

Duration : 3 Hours

Part – A

Answer all questions, each question carries 3 marks

1. Define Non-destructive testing?
2. Explain the basic principle of Visual testing?
3. Explain the sequence of operation of Liquid penetrant testing?
4. Explain the basic principle of Liquid penetrant testing?
5. How are the materials classified based on their interaction with a magnetic field?
6. Explain the Hysteresis Loop and Magnetic Properties of a material?
7. Compare X-rays and Gamma rays?
8. What is Snell's Law and its significance in Ultrasonic Testing?
9. Define the terms (a) Radiation Energy, (b) Intensity
10. What are the physical aspects of E.C.T?

PART -B

Answer one full question from each module.

MODULE – 1

11. a) With the help of suitable examples, differentiate between destructive and nondestructive testing techniques. (8 Mark)

b) With the help of a neat diagram, explain computer enhanced visual inspection system. (6 Mark)

OR

12. a) Explain visual inspection process. Also explain about the different types of optical aids used in the process. (8 Mark)  
b) List the applications and Limitations of Visual inspection technique in NDT (6 Mark)

#### MODULE – 2

13. a) How are the penetrants classified based on (8 Mark)  
a. Physical properties  
b. Removal techniques  
c. Strength of indication

b) What are the methods used to remove excess penetrants during LPI (6 Mark)

OR

14. a) Explain the working principle of liquid penetrant inspection (LPI). With neat sketches explain the various steps involved in performing LPI. (8 Mark)  
b) Explain different types of developers and how it is being applied (6 Mark)

#### MODULE – 3

15. a) With the help of neat sketches explain about any four types of magnetization techniques used in magnetic particle inspection (MPI). (8 Mark)  
b) What are the differences between dry and wet continuous MPI? (6 Mark)

OR

16. a) Differentiate between direct and indirect method of magnetization. Write the advantages and disadvantages of both methods. (8 Mark)  
b) What is continuous testing and residual technique of MPI (6 Mark)

#### MODULE – 4

17. a) With the help of neat figures, differentiate between through transmission technique and pulse echo testing techniques used in ultrasonic testing. (8 mark)  
b) What are the different types of probes used in ultrasonic testing? (6 mark)

OR

18. a) What are the different wave forms used in ultrasonic testing? (8 Mark)  
b) With neat sketches explain the following: (6 mark)  
i) A-Scan ii) B-Scan iii) C-Scan

#### MODULE – 5

19. a) With neat sketches explain about the different inspection techniques in radiography testing (RT). (8 Mark)  
b) Explain about various steps involved in film processing in RT. (6 mark)

OR

20. a) Explain the following terms associated with ECT: (8 Mark)  
i) Lift off effect ii) Edge effect iii) End effect  
b) Explain about eddy current testing (ECT) technique in detail. (6 mark)

## SYLLABUS

### Module 1

NDT Versus Mechanical testing-Overview of the Non Destructive Testing Methods for the detection of manufacturing defects as well as material characterisation-Relative merits and limitations-various physical characteristics of materials and their applications in NDT.

Visual Inspection: Fundamentals of Visual Testing – vision, lighting, material attributes, environmental factors, visual perception, direct and indirect methods – mirrors, magnifiers, Boroscopes and fibro scopes– light sources and special lighting–calibration- computer enhanced system

### Module 2

Liquid Penetrant Inspection: Principles – types and properties of liquid penetrants – developers – advantages and limitations of various methods - Preparation of test materials – Application of penetrants to parts, removal of excess penetrants, post cleaning – Control and measurement of penetrant process variables –selection of penetrant method – solvent removable, water washable, post emulsifiable – Units and lighting for penetrant testing – calibration- Interpretation and evaluation of test results - dye penetrant process applicable codes and standards.

### Module 3

Magnetic Particle Inspection (MPI): Important terminologies related to magnetic properties of material, principle-magnetizing technique, procedure, and equipment, fluorescent magnetic particle testing method, sensitivity-application and limitation-Methods of magnetization, magnetization techniques such as head shot technique, cold shot technique- central conductor testing, and magnetization using products using yokes-direct and indirect method of magnetization - continuous testing of MPI, residual technique of MPI- checking devices in MPI, Interpretation of MPI, indications, advantage and limitation of MPI.

### Module 4

Ultrasonic Testing: Basic principles of sound propagation, types of sound waves, Principle of UT-methods of UT, their advantages and limitations-Piezoelectric Material, Various types of transducers/probe-Calibration methods, contact testing and immersion testing, normal beam and straight beam testing, angle beam testing, dual crystal probe, ultrasonic testing techniques resonance testing, through transmission technique, pulse echo testing technique, instruments

used UT, accessories such as transducers, types, frequencies, and sizes commonly used. Reference of standard blocks-technique for normal beam inspection-flaw characterization technique, defects in welded products by UT-Thickness determination by ultrasonic method;- Study of A, B and C scan presentations-Time of Flight Diffraction (TOFD).

#### Module 5

Radiography: X-rays and Gamma rays, Properties of X-rays relevant to NDE - Absorption of rays - scattering. Characteristics of films- graininess, Density, Speed, Contrast. Characteristic curves. Inspection techniques like SWSI, DWSI, DWDI, panoramic exposure, real time radiography, films used in industrial radiography

Eddy Current Testing: Generation of eddy currents – effect of change of impedance on instrumentation – properties of eddy currents – eddy current sensing elements, probes, type of coil arrangement – absolute, differential, lift off, operation, applications, advantages, limitations Field factor and lift of effect, edge effect, end effect, impedance plane diagram in brief, depth of penetration of ECT, relation between frequency and depth of penetration in ECT.

#### Text Books

1. Baldev Raj, Practical Non – Destructive Testing, Narosa Publishing House, 1997
2. J.Prasad and C. G. K. Nair, Non-Destructive Test and Evaluation of Materials, Tata McGraw-Hill Education, 2nd edition (2011).
3. B.Raj, T. Jayakumar and M. Thavasimuthu, Practical Non Destructive Testing, Alpha Science International Limited, 3 rd edition (2007).
4. T. Rangachari, J. Prasad and B.N.S. Murthy, Treatise on Non-destructive Testing and Evaluation, Navbharath Enterprises, Vol.3, (1983).
5. Ed. Peter.J. Shull, Non-destructive Evaluation: Theory, Techniques, and Applications, Marcel Dekker (2002). 2.

#### Reference Books

1. C. Hellier, Handbook of Non-Destructive Evaluation, McGraw-Hill Professional, 1st edition (2001).
2. J. Thomas Schmidt, K. Skeie and P. MacIntire, ASNT Non Destructive Testing Handbook: Magnetic Particle Testing, American Society for Non-destructive Testing, American Society for Metals, 2nd edition (1989).
3. Krautkramer, Josef and Hebert Krautkramer, Ultrasonic Testing of Materials, Springer Verlag, 1990



Course Contents and Lecture Schedule

No	Topic	No. of Lectures
MODULE 1		
1.1	NDT Versus Mechanical testing-Overview of the Non Destructive Testing Methods for the detection of manufacturing defects as well as material characterisation	2
1.2	Relative merits and limitations-various physical characteristics of materials and their applications in NDT	1
1.3	Fundamentals of Visual Testing – vision, lighting, material attributes, environmental factors, visual perception, direct and indirect methods	1
1.4	Mirrors, magnifiers, Boroscopes and fibro scopes	1
1.5	light sources and special lighting, calibration- computer enhanced system	2
MODULE 2		
2.1	Liquid Penetrant Inspection: Principles – types and properties of liquid penetrants – developers	1
2.2	Advantages and limitations of various methods - Preparation of test materials	1
2.3	Application of penetrants to parts, removal of excess penetrants, post cleaning	1
2.4	Control and measurement of penetrant process variables –selection of penetrant method	1
2.5	solvent removable, water washable, post emulsifiable – Units and lighting for penetrant testing	1
2.6	calibration- Interpretation and evaluation of test results - dye penetrant process applicable codes and standards	2
MODULE 3		
3.1	Magnetic Particle Inspection (MPI): Important terminologies related to magnetic properties of material	1
3.2	Principle-magnetizing technique, procedure, and equipment, fluorescent magnetic particle testing method, Sensitivity	1
3.3	Methods of magnetization, magnetization techniques such as head shot technique, cold shot technique- central conductor testing,	1
3.4	magnetization using products using yokes-direct and indirect method of magnetization - continuous testing of MPI	1
3.5	residual technique of MPI- checking devices in MPI	1
3.6	Indications, advantage and limitation of MPI.	1
MODULE 4		
4.1	Ultrasonic Testing: Basic principles of sound propagation, types of	

	sound waves, Principle of UT-methods of UT	1
4.2	Piezoelectric Material, Various types of transducers/probe Calibration methods, contact testing and immersion testing, normal beam and straight beam testing,	1
4.3	Angle beam testing, dual crystal probe, ultrasonic testing techniques resonance testing, through transmission technique, pulse echo testing technique	1
4.4	Accessories such as transducers, types, frequencies, and sizes commonly used. Reference of standard blocks	1
4.5	Technique for normal beam inspection Thickness determination by ultrasonic method	1
4.6	Study of A, B and C scan presentations, Instruments used UT	1
4.7	Time of Flight Diffraction (TOFD).	1
MODULE 5		
5.1	Radiography: X-rays and Gamma rays, Properties of X-rays relevant to NDE - Absorption of rays - scattering	1
5.2	Characteristics of films- graininess, Density, Speed, Contrast. Characteristic curves. Inspection techniques like SWSI, DWSI, DWDI	1
5.3	Panoramic exposure, real time radiography, films used in industrial radiography	1
5.4	Eddy Current Testing: Generation of eddy currents – effect of change of impedance on instrumentation – properties of eddy currents	1
5.5	Eddy current sensing elements, probes, type of coil arrangement – absolute, differential, lift off, operation, applications, advantages, limitations	1
5.6	Field factor and lift of effect, edge effect, end effect, impedance plane diagram in brief, depth of penetration of ECT	1
5.7	Relation between frequency and depth of penetration in ECT.	1

COURSE CODE	COURSE NAME	CATEGORY	L	T	P	CREDITS
22MEE604.2	COMPUTATIONAL FLUID DYNAMICS	PROGRAM ELECTIVE 1	2	1	0	3

**Preamble:**

This course introduces the students to finite difference methods as a means of solving different types of differential equations that arise in fluid dynamics and heat transfer. Fundamentals of numerical analysis, ordinary differential equations and partial differential equations related to fluid mechanics and heat transfer will be reviewed. Error control and stability considerations are discussed. A class of methods used in computational fluid dynamics for numerically solving the Navier-Stokes equations normally for incompressible flows will be covered in this course.

Prerequisite: MET 203 Mechanics of Fluids

Course Outcomes: After the completion of the course the student will be able to

CO 1	Understanding the governing equations dominating fluid flow and heat transfer and their mathematical and physical nature.
CO 2	Understand finite difference method to fluid flow problems and the level of errors associated with these methods.
CO 3	Understand and apply finite volume method to fluid flow and heat transfer problems.
CO 4	Understand and apply finite volume method to diffusion and convection problems and various interpolation schemes.
CO 5	Understand various methods in numerically solving Navier Stokes equation for incompressible flows.
CO 6	Understand various graphical techniques to present post processed results.

**Mapping of course outcomes with program outcomes**

	PO 1	PO 2	PO 3	PO 4	PO 5	PO 6	PO 7	PO 8	PO 9	PO 10	PO 11	PO 12
CO 1	3	2										
CO 2	3	2	1									
CO 3	3	3	1									
CO 4	3	3	1									
CO 5	3	2	1									
CO 6	3	2	1									

**Assessment Pattern**

Bloom's Category	Continuous Assessment Tests		End Semester Examination
	1	2	
Remember	10	10	10
Understand	20	20	20
Apply	20	20	70
Analyse			
Evaluate			
Create			

## Mark distribution

Total Marks	CIE	ESE	ESE Duration
150	50	100	3 hours

### Continuous Internal Evaluation Pattern:

Attendance	: 10 marks
Continuous Assessment Test (2 numbers)	: 25 marks
Assignment/Quiz/Course project	: 15 marks

End Semester Examination Pattern: There will be two parts; Part A and Part B. Part A contain 10 questions with 2 questions from each module, having 3 marks for each question. Students should answer all questions. Part B contains 2 questions from each module of which student should answer any one. Each question can have maximum 2 sub-divisions and carry 14 marks.

### Course Level Assessment Questions

#### Course Outcome 1 (CO1):

- 1 Derive Navier Stokes equation in conservative form
- 2 Write a note on elliptical, parabolic and hyperbolic PDEs as applicable to CFD
- 3 Explain the applications of CFD in various industries.

#### Course Outcome 2 (CO2)

- 1 Explain finite difference method in brief. Give the justification for the choice for the finite difference method
- 2 Write a note on central and upwind difference schemes for one dimensional steady convection-diffusion equation
- 3 Obtain a 5-point centre-difference scheme for  $\frac{\partial^2 \phi}{\partial x^2}$  at grid-point  $i$  using  $\phi_{i-2}, \phi_{i-1}, \phi_i, \phi_{i+1}, \phi_{i+2}$  and find its truncation error.

#### Course Outcome 3(CO3):

1. Consider a heat conduction problem governed by  $\frac{\partial T}{\partial t} = \alpha \frac{\partial^2 T}{\partial x^2}$ . Develop a finite difference representation for this equation by the control-volume approach. Do not assume that the grid is uniform.
2. Explain the features of TDMA method
3. Write a note on explicit and implicit approaches and stability criteria.

#### Course Outcome 4 (CO4):

1. A property  $\phi$  is transported by means of convection and diffusion through the one-dimensional domain. The governing equation is  $[D_w - (De - Fe) - (Fe - F_w)] P - D_w W - (De - Fe) E$ ; the boundary conditions are  $\phi_0 = 1$  at  $x = 0$  and  $\phi L = 0$  at  $x = L$ . Using QUICK scheme for convection and diffusion, calculate the distribution of  $\phi$  as a function of  $x$  for (i) Case 1:  $u = 0.1$  m/s, (ii) Case 2:  $u = 2.5$  m/s

2. Explain Crank-Nicolson implicit scheme used for solving the parabolic partial differential equations
3. A property  $\phi$  is transported by means of convection and diffusion through the one-dimensional domain. The governing equation is  $[D_w (De - Fe) - (Fe - Fw)] P = D_w W (De - Fe) - E$ ; the boundary conditions are  $\phi_0 = 1$  at  $x = 0$  and  $\phi_L = 0$  at  $x = L$ . Using upwind differencing scheme for convection and diffusion, calculate the distribution of  $\phi$  as a function of  $x$  for (i) Case 1:  $u = 0.1$  m/s, (ii) Case 2:  $u = 2.5$  m/s with the coarse five-point grid

Course Outcome 5 (CO5):

1. Derive the expression for vorticity at the wall in terms of stream function. The expression should contain the interior points only. One could use no-slip velocity boundary condition at the wall in deriving the expression.
2. Write vorticity stream function equations
3. Describe the philosophy of Pressure Correction technique. Explain how boundary conditions are specified consistent with the philosophy of Pressure Correction method

Course Outcome 6 (CO6):

1. Explain SIMPLE Algorithm
2. Derive Pressure Correction formula considering two dimensional flows and explain step by step procedure for SIMPLE algorithm
3. Write a note on computer graphics techniques used to present post processed CFD results

SIXTH SEMESTER B.TECH DEGREE EXAMINATION  
Course Code: MET 322  
Course Name: COMPUTATIONAL FLUID DYNAMICS

Max. Marks: 100

Duration: 3 Hours

PART A

ANSWER ALL QUESTIONS, EACH QUESTION CARRIES 3 MARKS)

1. Explain the merits and demerits of numerical approaches over theoretical and experimental approaches.
2. Show that the second-order wave equation is a hyperbolic partial differential equation.
3. Using Taylor series, derive a first order and a second order difference equation for  $\frac{\partial u}{\partial y}$ .
4. Explain the relaxation techniques used in numerical schemes.
5. Explain Dirichlet, Neumann, and Robins type boundary conditions.
6. Derive the difference equation for steady one-dimensional heat conduction problem.
7. Discuss a situation where upwind differencing scheme is preferred over central differencing scheme.
8. Suggest a numerical difference scheme for which numerical false diffusion is desirable and justify your suggestion.
9. Explain any three graphical methods to present CFD results.
10. Discuss the importance of staggered grid in numerically solving incompressible viscous flow problems. ( 10 X 3 = 30 Marks )

PART B

Module 1

(ANSWER ONE FULL QUESTION FROM EACH MODULE)

11. Explain the significance of parabolic, hyperbolic and elliptic partial differential equations in a numerical perspective. ( 14 Marks )
12. Write down the Navier-Stokes equation in vector form by clearly mentioning the solution vector, flux vector and source vector. Convert the Navier-Stokes equations into non-dimensional form. ( 14 Marks )

Module 2

13. Consider the viscous flow of air over a flat plate. At a given station in the flow direction, the variation of the flow velocity,  $u$ , in the direction perpendicular to the plate (the  $y$  direction) is given by the expression  $u = 21582 \left( 1 - e^{-\frac{y}{L}} \right)$  where  $L =$  characteristic length = 0.05 m. The unit of  $u$  is m/s. The viscosity coefficient  $\mu = 1.81 \times 10^{-5}$  kg/(m.s). Using the equation for  $u$ , find the values of  $u$  at discrete grid points equally spaced in the  $y$  direction with  $\Delta y = 0.002$ m. With the values obtained at discrete grid points located at  $y=0, 0.002$  m,  $0.004$  m, and  $0.006$  m, calculate the shear stress at the wall  $\tau_w$  (a) using a first order difference equation and (b) second order difference equation. Compare these calculated finite difference results with the exact value of  $\tau_w$  which can be found by making use of the expression for  $u$ . ( 14 Marks )

14. The equation for deflection of a beam is given by  $\frac{d^2y}{dx^2} - e^{x^2} = 0$  and deflection at  $x = 0$  and  $x = 1$  are given by  $y(0) = 0$  and  $y(1) = 0$ . Use the difference equations to find the approximate deflection at  $x = 0.25, 0.5$ , and  $0.75$ . ( 14 Marks )

### Module 3

15. Consider the problem of source-free heat conduction in an insulated rod of 0.5 m length whose ends are maintained at constant temperatures of 100°C and 500°C respectively. The one-dimensional problem is governed by  $\frac{d}{dx} \left( \frac{k \cdot dT}{dx} \right) = 0$ . Calculate the steady state temperature distribution in the rod using finite volume method. Thermal conductivity  $k$  equals 1000 W/m.K, cross-sectional area  $A$  is  $10 \times 10^{-3} \text{m}^2$ . Use cell centered grid points. ( 14 Marks )
16. Two plastic sheets, each 5 mm thick, are to be bonded together with a thin layer of adhesive that fuses at 140 °C. For this purpose, they are pressed between two surfaces at 250 °C. Using finite volume method, determine the time for which the two sheets should be pressed together, if the initial temperature of the sheets (and the adhesive) is 30 °C. For plastic sheets, thermal conductivity  $k=0.25$  W/m-K, specific heat  $C=2000$ J/kg-K and density,  $\rho=1300$  kg/m<sup>3</sup>. ( 14 Marks )

### Module 4

17. A property  $\phi$  is transported by means of convection and diffusion through the one-dimensional domain  $0 \leq X \leq L$ . The governing equation is  $\frac{d}{dx} \rho u \phi = \frac{d}{dx} \Gamma \left( \frac{d\phi}{dx} \right)$ ; the boundary conditions are  $\phi_0 = 1$  at  $x = 0$  and  $\phi_L = 0$  at  $x = L$ . Using five equally spaced cells and the central differencing scheme for convection and diffusion, calculate the distribution of  $\phi$  as a function of  $x$  for  $u = 0.1$ m/s. Compare the results with the analytical solution  $(\phi - \phi_0)(\phi_L - \phi_0) = \frac{\rho u x}{(e^{\Gamma} - 1)}$ . ( 14 Marks )
18. Make a comparison of central differencing scheme and upwind differencing scheme. Explain the influence of numerical false diffusion on these two schemes. ( 14 Marks )

### Module 5

19. Derive the stream function- vorticity formulation for the Navier-Stokes equation by clearly stating the assumptions. ( 14 Marks )
20. Explain the SIMPLE algorithm. Make a discussion of the pressure correction equation and the boundary conditions for the pressure correction equation. ( 14 Marks )

## Syllabus

### MODULE : 1

Governing equations of fluid mechanics and heat transfer; fundamental equations – continuity equation, momentum equation and energy equation; non-dimensional form of equations; boundary layer equations for steady incompressible flows. Physical and mathematical classifications of partial differential equations. Comparison of experimental, theoretical and numerical approaches; applications of CFD.

### MODULE : 2

Discretization-converting derivatives to their finite difference forms-Taylor's series approach, polynomial fitting approach; forward, backward and central differencing Schemes. Discretization error, truncation error, round off error. Consistency and numerical stability, iterative convergence, condition for convergence, rate of convergence; under and over relaxations, termination of iteration.

### MODULE : 3

Finite volume method for Steady one-dimensional conduction problems; handling of boundary conditions; two-dimensional steady state conduction problems; point-by-point and line-by-line method of solution; dealing with Dirichlet, Neumann, and Robins type boundary conditions; tri-diagonal matrix algorithm; transient heat conduction problems - explicit, implicit, Crank-Nicholson and ADI schemes.

### MODULE : 4

Finite volume method for diffusion and convection-diffusion problems; steady one-dimensional convection and diffusion; upwind, hybrid, power-law and QUICK schemes; false diffusion.

### MODULE : 5

Computation of the flow field using stream function-vorticity formulation. Two dimensional incompressible viscous flow. Staggered grid. Pressure correction methods. Solution algorithm for pressure-velocity coupling in steady flows-SIMPLE algorithm. Boundary conditions for the pressure correction method. Computer graphics techniques to present CFD results.

### Text Books

1. S V Patankar, Numerical Heat Transfer and Fluid Flow, McGraw-Hill
2. John D Anderson Jr, Computational Fluid Dynamics, McGraw-Hill Book Company

### Reference Books

1. K Muralidhar, T Sundararakjan, Computational Fluid Flow and Heat transfer, Narosa, 2<sup>nd</sup> Edition, 2011
2. Tapan K Senguptha, Computational Fluid Dynamics, University Press, 2005



## Course Contents and Lecture Schedule

No	Topic	No. of Lectures
<b>Module I</b>		
1	Fundamental equations fluid mechanics and heat transfer	1
2	Continuity equation, momentum equation and energy equation;	2
3	Non-dimensional form of equations	1
4	Boundary layer equations for steady incompressible flows.	1
5	Physical and mathematical classifications of partial differential equations.	1
6	Comparison of experimental, theoretical and numerical approaches; applications of CFD.	1
<b>Module II</b>		
1	Discretization-converting derivatives to their finite difference forms-Taylor's series approach and polynomial fitting approach	1
2	Forward, backward and central differencing Schemes.	1
3	Discretization error, truncation error, round off error	1
4	Consistency and numerical stability	1
5	Iterative convergence, condition for convergence, rate of convergence	1
6	Under and over relaxations, termination of iteration.	1
<b>Module III</b>		
1	Finite volume method for steady one-dimensional conduction problems	1
2	handling of boundary conditions;	1
3	two-dimensional steady state conduction problems; point-by-point and line-by-line method of solution;	1
4	dealing with Dirichlet, Neumann, and Robins type boundary conditions;	1
5	tri-diagonal matrix algorithm;	1
6	transient heat conduction problems -explicit, implicit, Crank-Nicholson schemes	2
7	ADI scheme	1
<b>Module IV</b>		
1	Finite volume method for diffusion and convection-diffusion problems;	1
2	Upwind scheme for steady one-dimensional convection and diffusion	1
3	Hybrid scheme and power-law scheme	2
4	QUICK scheme	1
5	Numerical false diffusion	1
<b>Module V</b>		
1	Computation of the flow field using stream function-vorticity formulation.	2
2	Two dimensional incompressible viscous flow.	1
3	Staggered grid. Pressure correction methods.	1
4	Solution algorithm for pressure-velocity coupling in steady flows-SIMPLE algorithm.	2
5	Boundary conditions for the pressure correction method.	1
6	Computer graphics techniques to present CFD results.	1

COURSE CODE	COURSE NAME	CATEGORY	L	T	P	CREDITS
22MEE604.3	ADVANCED MECHANICS OF SOLIDS	PROGRAM ELECTIVE 1	2	1	0	3

Preamble: This elective course is designed to guide the student to move to the next level of what was included in the third semester course on Strength of Materials (MET 201 MECHANICS OF SOLIDS). Some of the materials which are usually preliminary for a paper like this, have got discussed in that prerequisite, and hence not repeated here. Application of stress and strain analysis in two and three dimensions to solve engineering problems is what is aimed at. The course is supposed to serve necessary background material for future courses on Finite Element Method, and advanced courses on Elasticity.

Prerequisite: MET 201 MECHANICS OF SOLIDS

Course Outcomes: After the completion of the course the student will be able to

CO 1	Formulate the field equations of Elasticity.
CO 2	Model some engineering problems as two-dimensional, for easy solutions involving a Stress Function.
CO 3	Develop solutions for axi-symmetric problems for applications in thick pressure vessels and in rotating circular discs.
CO 4	Extend the basic ideas related to theory of elastic flexure, for skewed loading and for beams which are curved.
CO 5	Apply solution methods for torsion in components with non-circular cross sections and thin walled structures.

Mapping of course outcomes with program outcomes

	PO 1	PO 2	PO 3	PO 4	PO 5	PO 6	PO 7	PO 8	PO 9	PO 10	PO 11	PO 12
CO 1	3	2	1									
CO 2	2	3	1									
CO 3	2	3	1									
CO 4	3	2	1									
CO 5	2	3	1									

Assessment Pattern

Bloom's Category	Continuous Assessment Tests		End Semester Examination
	1	2	
Remember	10	10	10
Understand	20	20	20
Apply	20	20	70
Analyse			
Evaluate			
Create			

## Mark distribution

Total Marks	CIE	ESE	ESE Duration
150	50	100	3 hours

### Continuous Internal Evaluation Pattern:

Attendance	: 10 marks
Continuous Assessment Test (2 numbers)	: 25 marks
Assignment/Quiz/Course project	: 15 marks

End Semester Examination Pattern: There will be two parts; Part A and Part B. Part A contain 10 questions with 2 questions from each module, having 3 marks for each question. Students should answer all questions. Part B contains 2 questions from each module of which student should answer any one. Each question can have maximum 2 sub-divisions and carry 14 marks.

### Course Level Assessment Questions

#### Course Outcome 1 (CO1):

1. Formulate all Field equations of elasticity.
2. Establishing the compatibility equations.
3. Realizing the differences between the formulation strategies of solutions in solid mechanics.
4. Formal proof for the uniqueness of the intended solutions.

#### Course Outcome 2 (CO2)

1. Realization that a vast majority of problems reduces to two-dimensional (either plane-stress or plane strain).
2. Formulating the Airy's stress function for two-dimensional problems.
3. Extending the Airy's method to solve practical problems like that encountered in contact analysis.

#### Course Outcome 3(CO3):

1. Formulation of equation for stresses and deflections in axi-symmetric problems.
2. Extend the axi-symmetric solutions for engineering applications in structures which are pressurised from the inside, as well as outside.
3. Extend the axi-symmetric theory to solve stresses and deformations in spinning discs.

#### Course Outcome 4 (CO4):

1. Extend the basic elastic flexure formula to cases when the load is skewed.
2. Develop the necessary framework to solve stresses in curved beams.

Course Outcome 5 (CO5):

1. Applying the St. Venant's torsion theory for non-circular cross sections
2. Applying Prandtl's Stress Function to solve Torsion and its applicability in terms of Membrane Analogy.
3. Stress analysis in thin walled closed sections.

### Model Question paper

APJ ABDUL KALAM TECHNOLOGICAL UNIVERSITY

SIXTH SEMESTER B.TECH DEGREE EXAMINATION

Course Code : MET332 Course Name : ADVANCED MECHANICS OF SOLIDS

Max. Marks : 100

Duration : 3 Hours

PART – A (ANSWER ALL QUESTIONS, EACH QUESTION CARRIES 3 MARKS)

1. Discuss the different types of boundary conditions encountered in the solution of elasticity problems.
2. What are Compatibility equations? Why are they essential in solving elasticity problems?
3. Express stress-strain relations in Matrix format for Plane-Stress and Plane-Strain problems.
4. Elucidate an example for the application of superposition in solving contact stress problems.
5. Derive expressions for circumferential and axial stresses in a thin cylindrical pipe of diameter 'd', thickness 't' and subjected to internal pressure 'P'.
6. Derive expressions for Circumferential Strain and Radial Strain for a two-dimensional thick cylinder (axi-symmetric) problem.
7. Discuss the significance of Shear-Centre in solving Bending of beams.
8. State all relevant assumptions in solving bending stress problems in curved beams using Winkler-Bach theory.
9. Elucidate the difference in approach between St. Venant's theory and Prandtl's theory in the solution of torsion problems.

10. How are torsion problems solved experimentally, making use of Prandtl's membrane analogy?

PART – B (ANSWER ONE FULL QUESTION FROM EACH MODULE)

MODULE – 1

11. (a) For a two-dimensional stress problem described using cylindrical coordinates, derive the equations of equilibrium in terms of  $(r, \theta)$ . (10 Marks)

(b) For the following plane strain distribution, verify whether the compatibility condition is satisfied:

$$\epsilon_{xx} = 3x^2y, \epsilon_{yy} = 4y^2x + 10^{-2}, \gamma_{xy} = 2xy + 2x^3 \quad (4 \text{ Marks})$$

12. (a) Given the fact that the strain energy density is positive-definite, show that the field equations of elasticity yields a Unique solution for a given system of forces and boundary conditions. (8 marks)

(b) Derive the equations of equilibrium in rectangular Cartesian coordinates. (6 Marks)

MODULE – 2

13. Figure shows a cantilever (of depth  $2c$ ) loaded by u.d.l. of magnitude 'q'. If the Airy's stress function for this problem is  $\phi = A [y^5 - 2c^2y^3 - 10x^2y^3 + 30c^2x^2y - 20c^3x^2]$ , (a) show that it is an acceptable stress function for Airy's method and (b) evaluate 'A' for this problem. (14 Marks)

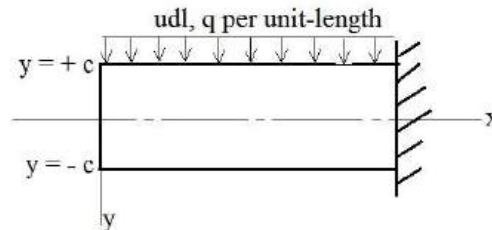

14. If the Airy' stress function ( $\phi$ ) in polar coordinates for solving contact stresses due to line-load on a straight boundary is  $\phi(r, \theta) = - (W/L \pi) r \theta \sin\theta$  ( where 'W/L' is the normal load per unit length), (a) show that it is an acceptable stress function for Airy's method (b) evaluate stresses for this two-dimensional stress-field (c) Show that the reactions offered by the resulting stress balances the externally applied load.

(14 Marks)

MODULE – 3

15. (a) Assuming plane stress, the stresses in a hollow thick cylinder of radius 'a' and external radius 'b' subjected to uniform (compressive) pressure of magnitude  $P_a$  and  $P_b$  inside and outside respectively is of the form

$$\sigma_r = \frac{E}{1 - \nu^2} \left[ C_1(1 + \nu) - C_2(1 - \nu) \frac{1}{r^2} \right]$$

$$\sigma_\theta = \frac{E}{1 - \nu^2} \left[ C_1(1 + \nu) + C_2(1 - \nu) \frac{1}{r^2} \right]$$

where 'r' is the radius at any point. Evaluate the constants  $C_1$  and  $C_2$ .

(b) Based on the above, develop expressions for (i) an internally pressurised thick cylinder and (ii) thick cylinder under external pressure. Plot the variation of stresses across thickness for both cases. (14 Marks)

16. A rotating disc ( $N=3500$  rpm) with a hole has an inner radius of 10 cm and outer radius of 35 cm. If the Poisson's ratio of the material is 0.3 and density is  $8050 \text{ kg/m}^3$ , (i) calculate and plot the distribution of radial and circumferential stresses across the radius (ii) Find the maximum values of radial and circumferential stresses. (14 Marks)

MODULE – 4

17. Find the maximum stress in the section A-B, if the cross-section is a square of sides 3cm x 3cm, for an applied load of  $P=3000\text{N}$ . Also, plot the variation of stresses across section, indicating the location of centroid and the neutral-axis. (14 Marks)

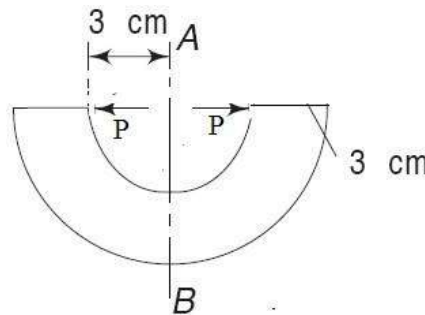

18. A rectangular beam with a 10 cm x 15 cm section is used as a simply supported beam of 3 m span. It carries a uniformly distributed load of 1470 N per meter. The load acts in a plane making  $30^\circ$  with the vertical. Calculate the maximum flexural stress at all corners of the cross-section at the mid-span and also locate the neutral axis for the same section.

(14 Marks)

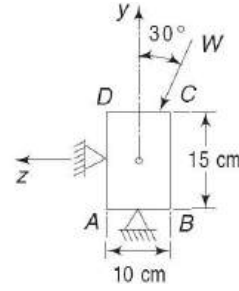
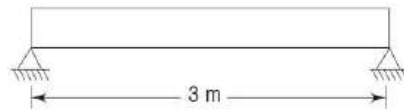

### MODULE – 5

19. Show that the stress function  $m \left[ \frac{x^2}{a^2} + \frac{y^2}{b^2} - 1 \right]$  is a valid Prandtl's stress function for solving torsion problem on an elliptical cross section of major axis  $2a$  and minor axis  $2b$ . Derive expressions for (i) Angle of twist per unit length (ii) Torsional rigidity (iii) Stresses (iv) Max. Stress. (14 Marks)

20. The cross-section of an aerofoil- model in a small wind-tunnel tested for the torque induced due to circulation around it, is idealized as shown in figure. If the shear strength of the material used for the model is  $40 \text{ MPa}$  and if the shear-modulus, ' $G$ ' is  $26 \text{ GPA}$ , find the limiting-torque for which it can be tested. How much would it deform (angular deflection) under this condition. Use  $3 \text{ mm}$  wall thickness all around. (14 Marks)

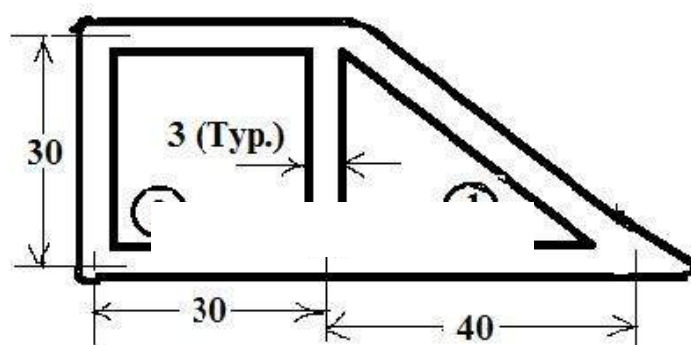

**All dimensions in mm**

## Syllabus

### Module 1

Field equations of Elasticity: Equations of equilibrium in rectangular and cylindrical polar coordinates – strain-displacement-relations - constitutive equations. Boundary value problems: Different boundary conditions- Examples for Displacement Formulation/ Force Formulation. Compatibility equations - Uniqueness of solution and superposition- St. Venant's principle.

### Module 2

Two dimensional problems in elasticity: Stress-strain relations for Plane stress and Plane strain cases. Airy's Stress Functions for solution of stresses: problems in Rectangular as well as in Polar coordinates- contact stresses due to concentrated normal force (line load) on a straight boundary using Airy's stress function, and its extension to solve for stresses due to uniform normal pressure.

### Module 3

Axisymmetric problems: Thin cylinders pressurized from inside, and thick cylinders pressurized from inside and outside - Rotating disks.

### Module 4

Unsymmetrical bending of straight beams possessing two axes of symmetry-shear center-Winkler Bach theory for Bending of curved beams (with rectangular cross-section).

### Module 5

Torsion of non-circular bars: St. Venant's and Prandtl's methods- solutions for elliptical cross-section. Membrane analogy –torsion of thin walled closed sections .

### Text Books

1. Nambudiripad K. B. M, "Advanced Mechanics of Solids- A Gentle Introduction", Narosa Publishing House, First Edition, 2018.
2. Srinath L. S., "Advanced Mechanics of Solids", Tata McGraw Hill Publishing Company, Third Edition, 2009.
3. Jose S., "Advanced Mechanics of Materials", Pentagon Educational Services, Second Edition, 2017.
4. Anil Lal S., "Advanced Mechanics of Solids", Siva Publications and Distributors, First Edition, 2017.



## Reference Books

1. Ragab A. R. and Bayoumi S. E., “Engineering Solid Mechanics, Fundamentals and Applications”, CRC Press, First Edition, 2018.
2. Timoshenko S. P., and Goodier J. N., “Theory of Elasticity”, McGraw Hill (India), Private Limited, NewDelhi, Third Edition, 2010.
3. Sadd M. H., “Elasticity: Theory, Applications and Numerics”, Academic Press, Indian reprint, 2<sup>nd</sup> edition, 2012.

## Course Contents and Lecture Schedule

No	Topic	No. of Lectures
1	Module-1: Field Equations	7
1.1	Review of Stress-tensor, strain-displacement relations and strain tensor. Derivation of Equilibrium equations in rectangular and polar coordinates.	2 Hours
1.2	Generalised Hooke’s law for linearly elastic, homogeneous isotropic solids	1 Hour
1.3	Boundary conditions in Elasticity problems with examples, Displacement Formulation/ Force Formulation Uniqueness of Solutions, Method of Super position	2 Hours
1.4	Compatibility equations, St. Venants Principle	2 Hours
2	Module-2: Two-dimensional problems	7
2.1	Stress-strain relations for Plane –stress and plane strain conditions	1 Hour
2.2	Formulation of the Airys stress function in Rectangular and Polar Coordinates	2 Hours
2.3	Illustrative examples for solutions using Airy’s stress function	2 Hours
2.4	Contact stresses due to concentrated normal force (line load) on a straight boundary using Airy’s stress function, and its extension to solve for stresses due to uniform normal pressure.	2 Hours
3	Module-3: Axi-symmetric Problems	7
3.1	Stresses in Thin Cylindrical shells and numerical problems.	1 Hour
3.2	Axisymmetric problems: Basic Formulation	1 Hour
3.3	Application to thick shells	1 Hour
3.4	Numerical problems related to thick shells	1 Hour
3.5	Formulation of rotating disks	1 Hour
3.6	Numerical problems related to rotating disks	2 Hours
4	Module-4: Special Topics in Bending	7
4.1	Unsymmetrical bending of straight beams possessing two axes of	1 Hour

	symmetry.	
4.2	Numerical problems related to Unsymmetrical bending of straight beams	2 Hours
4.3	Shear Centre	1 Hour
4.4	Winkler Bach theory for Bending of curved beams	1 Hour
4.5	Numerical problems related to Unsymmetrical bending of straight beams	2 Hours
5	Module-5: Torsion of Non-Circular Sections	7
5.1	St. Venant's torsion theory	2 Hours
5.2	Prandtl's torsion theory	1 Hour
5.3	Membrane Analogy	1 Hour
5.4	Torsion of thin walled cross sections	1 Hour
5.5	Numerical problems on torsion of thin walled sections	2 Hours

COURSE CODE	COURSE NAME	CATEGORY	L	T	P	CREDITS
22MEE604.4	IC ENGINE COMBUSTION AND POLLUTION	PROGRAM ELECTIVE 1	2	1	0	3

Preamble :

This course provides basic concepts on fuel-air mixing, theory of combustion in IC engines. To provide knowledge on emission control technologies of IC engines.

Prerequisite : Thermal Engineering

Course Outcomes :

~~After completion of the course the student will be able to~~

CO1	Explain the basic concepts of fuel air mixing
CO2	Understand the combustion process of SI engine
CO3	Understand the combustion process of CI engine
CO4	Explore various alternate fuels in IC engine
CO5	Describe emission control technologies of IC engine

Mapping of course outcomes with program outcomes

	PO1	PO2	PO3	PO4	PO5	PO6	PO7	PO8	PO9	PO10	PO11	PO12
CO1	3	2										
CO2	3	1										
CO3	3	1										
CO4	3	2				1	1					
CO5	3	1				1	1					

Assessment Pattern

Bloom Category	Continuous Assessment Tests		End Semester Examination
	1	2	
Remember	10	10	10
Understand	20	20	20
Apply	20	20	70
Analyse			
Evaluate			
Create			

Total Marks	CIE	ESE	ESE Duration
150	50	100	3 hours

Mark distribution:

Continuous Internal Evaluation Pattern:

Attendance : 10 marks

Continuous Assessment Test (2 numbers) : 25 marks

Assignment/Quiz/Course project : 15 marks

End semester pattern:

There will be two parts; Part A and Part B. Part A contain 10 questions with 2 questions from each module, having 3 marks for each question. Students should answer all questions. Part B contains 2 questions from each module of which student should answer any one. Each question can have maximum 2 sub-divisions and carry 14 marks.

Course Level Assessment Questions:

Course Outcome 1 (CO1):

1. Explain the different air-fuel ratios required for different operating conditions of a gasoline engine?
2. What are the different air fuel mixtures on which an engine can be operated?
3. Explain the following; 1.Richmixture, 2.Stoichiometric mixture3. Lean mixture.

Course Outcome 2 (CO2):

1. What are the major factors to be considered for the design of SI engine combustion chamber?
2. Define the terms flame development and flame propagation in engines
3. Using the pressure crank angle diagram (P- $\theta$ ) explain the different stages of desirable combustion in a SI engine .Also explain how abnormal combustion takes place (P- $\theta$ ) diagram?

Course Outcome 3 (CO3):

1. Briefly explain the thermodynamic analysis of CI engine combustion process.Explain clearly assumption made.
2. Explain the various factors that influence spray penetration in CI engine.
3. What is the effect of EGR in emissions from CI engine?

Course Outcome 4 (CO4):

1. Discuss the salient properties of hydrogen as a fuel.
2. What is the modification to be made in CI engine running on biodiesel? Explain in detail about the use of the biodiesel as fuel in CI engine and various merits and demerits of it use?
3. Explain the fuel characteristics of alcohols,CNG,LPG & hydrogen?

Course Outcome 5 (CO5):

1. List the major pollutants from SI engines. How can we measure and control each of them
2. What are the effects of pollutants from CI engines on environment and human beings? How can these be controlled to a certain extent.
3. Explain soot and particulate traps.

MODEL QUESTION PAPER  
APJ ABDUL KALAM TECHNOLOGICAL UNIVERSITY  
VI SEMESTER B.TECH DEGREE EXAMINATION  
MET342: IC ENGINE COMBUSTION AND POLLUTION

Maximum: 100 Marks

Duration: 3 hours

PART A

Answer all questions, each question carries 3 marks

1. What are the different air fuel mixtures on which an engine can be operated?
2. Why a SI engine requires a rich mixture during idling and at full load?
3. What are factors that influence the flame speed?
4. What are the various factors affecting knock in spark ignition engine?
5. State briefly about air motion in CI engines using diagrams.
6. What is the effect of delay period on Knock in CI engines?
7. List the components present in the measuring chain for pressure measurement in engine research.
8. Write about the different types of alternate fuels available.
9. What are the various pollutants present in combustion products?
10. What are emission norms? Give the major pollutants that are to be controlled?

(10 X 3 = 30 marks)

PART B

Answer one full question from each module

Module 1

11. Briefly explain the different air-fuel ratios required for different operating conditions of a gasoline engine? (14 marks)
12. Discuss the air fuel ratio requirements of SI engine? (14 marks)

Module 2

13. Explain the stages of combustion in SI engines with suitable flame propagation curve? (14 marks)
14. What is meant by abnormal combustion. Explain the phenomena of knock in SI engine? (14 marks)

### Module 3

15. Explain with figures various types of combustion chambers used in CI engine. (14 marks)
16. Explain the phenomenon of spray evaporation and combustion in CI engine (14 marks)

### Module 4

17. Explain the fuel characteristics of biodiesel, CNG,LPG &hydrogen? (14 marks)
18. Discuss about the HCCI engine. (14 marks)

### Module 5

19. Write short notes on the formation of particulate and smooth emission in IC engines? (14 marks)
20. Explain in detail about the different methods used for the measurement of exhaust Emission in petrol engine? (14 marks)

## Syllabus

### Module 1

Engine design and operating parameters, Thermo chemistry of fuel-air mixtures  
Properties of working fluids- unburned mixture composition, burned mixture charts, Exhaust gas composition.

### Module 2

Ideal models of engine cycles, Availability analysis of engine processes. Combustion in SI engines- Thermodynamic analysis, Flame structure and speed, Cyclic variations in combustion, partial burning and misfire, abnormal combustion

### Module 3

Combustion in CI engines- Phenomenological model of CI engine combustion, Analysis of cylinder pressure data, fuel spray behaviour

### Module 4

Utilization of alternate fuels in IC engines- biodiesel, hydrogen, LPG, Natural gas- Advantages and disadvantages- HCCI combustion, ASTM specifications

### Module 5

Engine emission and air pollution- Genesis and formation of pollutants, SI engine emission control technology - CI engine emission control technology, fuel quality, emission standards

Text Books:

1. Ganesan, Internal combustion engines, Tata- Mcgraw Hill Publishers, 2002
2. Ramalingam, K.K., Internal Combustion Engines, Scitech Publications (India) Pvt. Ltd., 2004.
3. F Obert, IC Engines and air pollution, Intext educational publishers, 1973
4. Mathur,M.L., and Sharma,R.P., A Course in Internal Combustion Engines, DhanpatRai Publications, 1993.

Reference Books:

1. Heywood JB, IC Engine fundamentals, McGraw hill book Co, 1989
2. W WPulkrabek, Engineering Fundamentals of the IC Engine, 2nd edition, PHI, 2003
3. B. P. Pundir, Engine Emissions: Pollutant formation and advances in control technology, NarosaPublication,2007

Course Contents and Lecture Schedule

No.	Topic	No. of Lectures
1		
1.1	Engine design and operating parameters, Thermo chemistry offuel-air mixtures	4
1.21.2	Properties of working fluids- unburned mixture composition, burned mixture charts, Exhaust gas composition.	3
2	Combustion in SI engines	
2.1	Ideal models of engine cycles, Availability analysis of engine processes.	2
2.2	Thermodynamic analysis, Flame structureand speed, Cyclic variations in combustion, partial burning and misfire,abnormal combustion	5
3	Combustion in CI engines	
3.1	Phenomenological model of CI engine combustion	4
3.2	Analysis of cylinder pressure data, fuel spray behavior	3
4	Utilization of alternate fuels in IC engines	
4.1	Biodiesel, hydrogen, LPG,Natural gas- Advantages and disadvantages	5
4.2	HCCI combustion, ASTMspecifications	2
5	Engine emission and air pollution	
5.1	Genesis and formation of pollutants	1

5.2	SI engine emission control technology	3
5.3	CI engine emission control technology, fuel quality, emission standards	3



COURSE CODE	COURSE NAME	CATEGORY	L	T	P	CREDITS
22MEE604.5	AUTOMOBILE ENGINEERING	PROGRAM ELECTIVE 1	2	1	0	3

**Preamble:**

The objective of this course is

- To know the anatomy of automobile in general
- To understand the working of different automotive systems and subsystems
- To update the latest developments in automobiles

Prerequisite: EST 120 Basics of Mechanical Engineering

Course Outcomes: After the completion of the course the student will be able to

CO 1	Explain different automotive systems and subsystems .
CO 2	Illustrate the principles of transmission, suspension, steering and braking systems of an automobile.
CO 3	Build a basic knowledge about the technology in electric vehicles.
CO 4	Summarize the concept of aerodynamics in automobiles.

Mapping of course outcomes with program outcomes

	PO1	PO2	PO3	PO4	PO5	PO6	PO7	PO8	PO9	PO10	PO11	PO12
CO1	3											3
CO2	3											3
CO3	3											3
CO4	3											3

Assessment Pattern

Bloom's Category	Continuous Assessment Tests		End Semester Examination
	1	2	
Remember	10	10	10
Understand	20	20	20
Apply	20	20	70
Analyse			
Evaluate			
Create			

## Mark distribution

Total Marks	CIE	ESE	ESE Duration
150	50	100	3 hours

### Continuous Internal Evaluation Pattern:

Attendance	: 10 marks
Continuous Assessment Test (2 numbers)	: 25 marks
Assignment/Quiz/Course project	: 15 marks

End Semester Examination Pattern: There will be two parts; Part A and Part B. Part A contain 10 questions with 2 questions from each module, having 3 marks for each question. Students should answer all questions. Part B contains 2 questions from each module of which student should answer any one. Each question can have maximum 2 sub-divisions and carry 14 marks.

### Course Level Assessment Questions

#### Course Outcome 1 (CO1):

1. What is the need of clutch and gearbox in an automobile?
2. List out the factors affecting the maximum torque transmitting capacity of a friction clutch,
3. Define over drive and list out its advantages.

#### Course Outcome 2 (CO2)

1. Explain Ackermann steering mechanism with a neat sketch.
2. Explain in detail the working and function of ABS braking system.
3. Explain the function and advantages of Double Wishbone Suspension system.

#### Course Outcome 3 (CO3):

1. What is the difference between an electric vehicle and a hybrid vehicle?
2. List out the differences in the chassis design of an electric vehicle comparing with the conventional chassis.
3. Explain the basic operation of a fuel cell.

#### Course Outcome 4 (CO4):

1. What is the significance of aerodynamic lift in vehicles?
2. Explain the concept of 'Hatch back Drag'.
3. What are the functions of negative lift aerofoil wings.

Model Question Paper  
SIXTH SEMESTER MECHANICAL ENGINEERING  
MET 352 AUTOMOBILE ENGINEERING

Max. Marks: 100

Duration: 3 Hours

PART A (30 marks)

*Answer all questions, each carries 3 marks.*

1. List the three types of chassis construction.
2. Explain the loads coming on a chassis frame.
3. Differentiate body roll couple and body overturning couple.
4. Explain the features of Double Wish Bone suspension system.
5. Describe any type of a regenerative brake system.
6. Illustrate the desirable properties of brake pad materials.
7. Define the terms under steer and over steer in automobiles.
8. Explain the advantages of power assisted steering system.
9. Explain the functions of negative lift aerofoil wings.
10. List out the advantages of rear end spoiler in a vehicle.

PART B (70 marks)

*Answer any one question from each module, each carries 14 marks.*

*Module 1*

11.	a)	Explain the working of worm and roller steering gearbox system with the help of a neat sketch.	(7)
	b)	Explain the common troubles encountered in gear boxes and suggest suitable remedies.	(7)
12.		Compare hydraulic, mechanical, electrical and vacuum methods of operating clutches. Describe a hydraulic operated clutch in detail with help of simple	(14)

		diagram.	
<i>Module 2</i>			
13.	a)	Explain the features of McPherson strut suspension system with a neat sketch.	( 8)
	b)	Explain the function of an antiroll bar in a four wheeled vehicle.	(6)
14.	a)	Illustrate the working of swing arm rear wheel drive independent suspension.	(8)
	b)	Explain the features of De Dion axle rear wheel suspension.	(6)
<i>Module 3</i>			
15.	a)	Explain how the braking efficiency of a vehicle is evaluated? Also detail the parameters that affect the braking efficiency.	(7)
	b)	Derive an expression for the brakes applied on front and rear wheels.	(7)
16.	a)	Discuss the working and advantages of ABS over conventional systems.	(8)
	b)	Explain the working of a brake caliper with a neat sketch.	(6)
<i>Module 4</i>			
17.	a)	Explain the working and advantages of turbocharger with a neat sketch.	(8)
	b)	Explain how oil control ring helps in piston lubrication.	(6)
18.	a)	Explain the basic principle of a hydrogen fuel cell and its efficiency.	(8)
	b)	Explain the technology of high speed electric trains.	(6)
<i>Module 5</i>			
19.	a)	Differentiate between fast back drag and hatch back drag.	(7)
	b)	Explain the methods to control the aerodynamic lift in vehicles.	(7)
20.	a)	Illustrate the influence of shape of vehicles on drag coefficients.	(7)
	b)	Explain how profile edge chamfering improves drag in vehicles.	(7)

## Syllabus

### Module 1

Components of an automobile. General classification. Conventional Chassis construction- Types of frames- Frameless constructions. Vehicle dimensions.

Friction clutch: Principle, dry friction clutches- Pull type diaphragm clutch, multiple diaphragm clutch, multi-plate hydraulically operated automatic transmission clutch, semi centrifugal clutch, fully automatic centrifugal clutch, and integral single plate diaphragm clutch. Electromagnetic clutch operation. Clutch friction materials, wet clutch.

Manual transmission- Need of gear box, power to weight ratio, speed operating range-five speed and reverse sliding mesh, constant mesh, and synchromesh gear boxes. Automatic transmission- Epicyclic gear box - torque convertor – Over drives. Automated manual transmission.

### Module 2

Suspension: - suspension geometry, terminology- Macpherson strut friction and spring offset - suspension roll centers:-roll centers, roll axis, roll centre height, short swing and long arm suspension, transverse double wishbone, parallel trailing double arm and vertical pill strut suspension, Macpherson strut suspension, semi-trailing arm rear suspension, telescopic suspension. High load beam axle leaf spring, sprung body roll stability. Rear axle beam suspension- body roll stability analysis:- body roll couple, body roll stiffness, body over turning couple.

Rear suspension: - live rigid axle suspension, non drive rear suspension- swing arm rear wheel drive independent suspension. Low pivot split axle coil spring wheel drive independent suspension, trailing and semi trailing arm rear wheel drive independent suspension. Transverse double link arm rear wheel drive independent suspension, De Dion axle rear wheel suspension - Hydrogen suspension, hydro-pneumatic automatic height correction suspension.

### Module 3

Brakes: mechanical and hydraulic brakes (review only) – properties of friction lining and pad materials, theory of internal shoe brake, equations –effect of expanding mechanism of shoes on total braking torque, equations. Braking of vehicles:- brakes applied on rear, front and all four wheels, equations –calculation of mean lining pressure and heat generation during braking operation, equations. – braking of vehicle moving on curved path, simple problems.

Anti Lock Braking system (ABS):- hydro-mechanical ABS - hydro-electric ABS - air-electric ABS. Brake servos: - direct acting suspended vacuum assisted brake servo unit operation - hydraulic servo assisted brake systems. Pneumatic operated disc brakes – electronic-pneumatic brakes. Regenerative braking system.

## Module 4

Steering:-basic principle of a steering system– Ackermann –over steer and under steer – slip angle, camber, , king pin inclination, caster, toe-in and toe-out .Steering gear box:-worm and roller type steering gear box – Re-circulating ball nut and rocker lever– need of power assisted steering.

Piston for IC engine, piston rings, piston pin, connecting rod, crank shaft, crank pin, cam shaft, valves, fly wheel, fluctuation of energy and size of fly wheel, hub and arms, stress in a fly wheel rim, simple problems. Fuel injection systems: multiport fuel injection (MPFI) and common rail direct injection (CRDI) systems. Super charging in engines, turbo charger, turbo lag.

Electric Vehicle Technology (EVT): EV Architecture, types of batteries, battery parameters, super capacitors. Fuel cells and its efficiency. EV Chassis – requirements, suspension for EVs. Recent Electric vehicles- Electric mobility aids. Future of electric vehicles –Tesla S, Maglev trains, Electric rail road systems.

## Module 5

Aerodynamic drag: pressure drag, air resistance, opposing motion of a vehicle, equations, after flow wake, drag coefficients, various body shapes, base drag, vortices, trailing vortex drag, attached transverse vortices. Aerodynamic lift:-lift coefficients, vehicle lift, underbody floor height versus aerodynamic lift and drag, aerofoil lift and drag, front end nose shape.

Car body drag reduction:-profile edge chamfering, bonnet slope and wind screen rake, roof and side panel chamfering, rear side panel taper, under body rear end upward taper, rear end tail extension, under body roughness. Aerodynamic lift control:- under body dams, exposed wheel air flow pattern, partial enclosed wheel air flow pattern, rear end spoiler, negative lift aerofoil wings. After body drag: - square back drag, fast back drag, hatch back drag, notch back drag.

## Text Books

1. Heinz Heisler, Vehicle and engine technology, Butterworth-Heinemann, 2<sup>nd</sup> edition,1998.
2. R.B. Gupta., Auto design , Satya Prakashan Publishers, New Delhi, 2016 .
3. James Larminie and John Lowry, Electric vehicle technology explained, Wiley publications, 2<sup>nd</sup> edition, 2015.
4. Kirpal Singh, Automobile Engineering Vol.1 & Vol.2, Standard Publishers, 13<sup>th</sup> edition, 2020.

## Reference Books

4. V.A.W. Hillier, Fundamentals of modern vehicle technology, Butterworth-Heinemann, 2<sup>nd</sup> edition,1998.

5. Tom Denton, Electric and Hybrid Vehicles, Routledge Publishers, 2nd edition, 2020.

Course Contents and Lecture Schedule

No	Topic	No. of Lectures
1	Clutch and transmission	
1.1	Introduction, Chassis construction- Types of frames.	1
1.2	Frameless construction, Vehicle dimensions	1
1.3	Principle of dry friction clutches- Single plate, Multi plate.	1
1.4	Semi centrifugal clutch, fully automatic centrifugal clutch, and	1
1.5	Integral single plate diaphragm clutch. Electromagnetic clutch operation., clutch friction materials, wet clutches	1
1.6	Sliding mesh, constant mesh , synchromesh gear boxes, epicyclic gear boxes	1
1.7	Torque converter, Over drives, Automated manual transmission	1
2	Suspension	
2.1	Suspension: - suspension geometry, terminology. Macpherson strut friction and spring offset.	1
2.2	Suspension roll centers:-roll centers, roll axis, roll centre height, short swing and long arm suspension.	1
2.3	Transverse double wishbone, parallel trailing double arm and vertical pillar strut suspension, Macpherson strut suspension, semi-trailing arm rear suspension, telescopic suspension.	1
2.4	High load beam axle leaf spring, sprung body roll stability. Rear axle beam suspension- body roll stability analysis:- body roll couple, body roll stiffness, body over turning couple.	1
2.5	Rear suspension: - live rigid axle suspension, non drive rear suspension- swing arm rear wheel drive independent suspension.	1
2.6	Low pivot split axle coil spring wheel drive independent suspension, trailing and semi trailing arm rear wheel drive independent suspension.	1
2.7	Transverse double link arm rear wheel drive independent suspension, De Dion axle rear wheel suspension. Hydrogen suspension, hydro-pneumatic automatic height correction suspension.	1
3	Brakes	
3.1	Types of Brakes, Properties of friction lining and pad materials.Theory	1

	of internal shoe brake, equations	
3.2	Effect of expanding mechanism of shoes on total braking torque, equations.	1
3.3	Braking of vehicles:- brakes applied on rear, front and all four wheels, equations.	1
3.4	Calculation of mean lining pressure and heat generation during braking operation, equations.	1
3.5	Braking of vehicle moving on curved path, simple problems. Hydro-mechanical ABS - hydro-electric ABS	1
3.6	Air-electric ABS. Brake servos: -direct acting suspended vacuum assisted brake servo unit operation - Hydraulic servo assisted brake systems.	1
3.7	Pneumatic operated disc brakes – electronic-pneumatic brakes. Regenerative braking systems.	1
4	Steering, Engine and EVT	
4.1	Ackermann steering mechanism, over steer and under steer .	1
4.2	Worm and roller type steering gear box, Re-circulating ball nut and rocker lever, power assisted steering.	1
4.3	IC engines, piston, rings, pin, flywheel, connecting rod.Crank shaft, crank pin, cam shaft, valve mechanism	1
4.4	Fuel injection systems ,Turbochargers, turbo lag.	1
4.5	EV Architecture, types of batteries, battery parameters, super capacitors. Fuel cells and its efficiency.	1
4.6	EV Chassis – requirements, suspension for EVs. Recent Electric vehicles- Electric mobility aids.	1
4.7	Future of electric vehicles –Tesla S, Maglev trains, Electric rail road systems.	1
5	Aerodynamics in automobiles	
5.1	Aerodynamic drag: pressure drag, air resistance, opposing motion of a vehicle.	1
5.2	Flow wake, drag coefficients, various body shapes, base drag, vortices, trailing vortex drag, attached transverse vortices.	1
5.3	Aerodynamic lift:-lift coefficients, vehicle lift. Under body floor height versus aerodynamic lift and drag.Aerofoil lift and drag, front end nose	1



	shape.	
5.4	Car body drag reduction:-profile edge chamfering, bonnet slope and wind screen rake.	1
5.5	Roof and side panel chamfering, rear side panel taper, under body rear end upward taper, rear end tail extension, under body roughness.	1
5.6	Aerodynamic lift control:- under body dams, exposed wheel air flow pattern, partial enclosed wheel air flow pattern, rear end spoiler, negative lift aerofoil wings.	1
5.7	After body drag: - square back drag, fast back drag, hatch back drag, notch back drag.	1

COURSE CODE	COURSE NAME	CATEGORY	L	T	P	CREDITS
22MEE604.6	PRODUCT DESIGN AND DEVELOPMENT	PROGRAM ELECTIVE 1	2	1	0	3

#### Preamble:

- To create confidence in developing new products.
- To acquaint with methods and tools for product design and development.
- To equip with practical knowledge in conceptualization, design and development of new product.

Prerequisite: NIL

Course Outcomes: After the completion of the course the student will be able to

CO 1	Determine the life cycle of a product and product development process
CO 2	Develop knowledge of robust design and conceptual design
CO 3	Introduce the concept of Design for Manufacturing and Assembly in product design.
CO 4	Use value engineering in the development of product
CO 5	Incorporate ergonomics and rapid prototyping in product development.

#### Mapping of course outcomes with program outcomes

	PO 1	PO 2	PO 3	PO 4	PO 5	PO 6	PO 7	PO 8	PO 9	PO 10	PO 11	PO 12
CO 1	3	3	2									
CO 2	3	3	2									
CO 3	3	3	2									
CO 4	3	3	2									
CO 5	3	3	2									

#### Assessment Pattern

Bloom's Category	Continuous Assessment Tests		End Semester Examination
	1	2	
Remember	10	10	10
Understand	20	20	20
Apply	20	20	70
Analyse			
Evaluate			
Create			

#### Mark distribution

Total Marks	CIE	ESE	ESE Duration
150	50	100	3 hours

Continuous Internal Evaluation Pattern:

Attendance	: 10 marks
Continuous Assessment Test (2 numbers)	: 25 marks
Assignment/Quiz/Course project	: 15 marks

End Semester Examination Pattern: There will be two parts; Part A and Part B. Part A contain 10 questions with 2 questions from each module, having 3 marks for each question. Students should answer all questions. Part B contains 2 questions from each module of which student should answer any one. Each question can have maximum 2 sub-divisions and carry 14 marks.

Course Level Assessment Questions

Course Outcome 1 (CO1):

1. State the features of a good product design.
2. Explain the morphology of design.
3. Describe about the product life cycle.

Course Outcome 2 (CO2)

1. Discuss the brainstorming technique.
2. Discuss about the robust design.
3. Describe the industrial design process.

Course Outcome 3(CO3):

1. Explain DFM Method in design.
2. Explain the importance of ergonomics in product design.
3. Explain the environmental impacts derived from the manufacturing sector.

Course Outcome 4 (CO4):

1. Discuss the advantages of value analysis.
2. Compare Value analysis and value engineering.
3. Discuss some of the quantitative economic analysis tool used in industry.

Course Outcome 5 (CO5):

1. Describe the steps in reverse engineering.
2. Explain the concept of Concurrent Engineering, Rapid prototyping
3. Explain about the patenting system.

## MODEL QUESTION PAPER

### SIXTH SEMESTER B. TECH DEGREE EXAMINATION

Course Code: MET362

Course Name: PRODUCT DESIGN AND  
DEVELOPMENT Max. Marks: 100

Duration: 3 Hours

#### PART – A

(ANSWER ALL QUESTIONS, EACH QUESTION CARRIES 3 MARKS)

1. How the different types of products are classified?
2. What are the various reasons for the failure of a new product?
3. What are three accuracy points in cam and follower synthesis?
4. What meant by the term “lines of maintenance”?
5. Analyze the corporate social responsibility in ethical view point?
6. Differentiate between fixed cost and variable cost?
7. Explain the term anthropometry?
8. What are the rights of a patentee?
9. Differentiate between drafting and modelling software with suitable examples?
10. Explain different steps in a 3d scanning process

#### PART – B

(ANSWER ONE FULL QUESTION FROM EACH MODULE)

##### Module 1

11. Explain the various steps involved the morphology of design? (14 marks)
12. Analyze the steps and responsibilities involved in the development of a new product with the help of an example? (14 marks)

##### Module 2

13. Discuss the various steps in robust design process? (14 marks)
14. Analyze the various activities involved in the industrial design process? (14marks)

##### Module 3

15. a) Elaborate the role of ergonomic factors in product design? (8 marks)  
b) Analyze the ergonomic factors that need to be considered in the design of a chair? (6 marks)

16. Explain how the design for assembly affects the product design with the help of two examples?

(14 marks)

#### Module 4

17. Define Value Engineering. Explain the application of the value engineering concept with the help of two case studies?

(14 marks)

18. How the cost of a product is determined? Explain with suitable example.

(14 marks)

#### Module 5

19. Analyze the major factors that contribute to the improved product quality by incorporating the concurrent engineering concept?

(14 marks)

20. Explain Stereo-lithography and Fused Deposition Modeling with sketch. Compare the advantages and disadvantages of these techniques?

(14 marks)

# Syllabus

## Module 1

Introduction: Classification/ Specifications of Products, Product life cycle, product mix.

Introduction to product design, Modern product development process Design by evolution, Design by innovation, Morphology of design

Ethics in product design, legal factors and social issues.

## Module 2

Creativity Techniques: Creative thinking, conceptualization, brain storming, primary design, drawing, simulation, detail design.

Conceptual Design: Generation, selection & embodiment of concept, Product architecture.

Industrial design: process, need.

Robust Design: Taguchi Designs, Design of experiments.

## Module 3

Design for Manufacturing and Assembly: Methods of designing for Manufacturing and Assembly.

Design for Maintenance. Design for Environment.

Ergonomics in product design.

Aesthetics in product design. Concepts of size and texture color.

## Module 4

Value Engineering / Value Analysis: Definition. Methodology, Case studies.

Product costing.

Economic analysis: Qualitative & Quantitative.

Psychological and Physiological considerations.

## Module 5

Concurrent Engineering -Elements of concurrent engineering, Benefits

Rapid prototyping: concepts, processes and advantages.

Reverse engineering: steps in reverse engineering- hardware and software in reverse engineering

Tools for product design – Drafting / Modeling software.

Patents & IP Acts- Overview, Disclosure preparation.

## Text Books

1. Karl T Ulrich, Steven D Eppinger, "Product Design & Development." Tata McGraw Hill, 2003.

## Reference Books

1. Baldwin E N & Neibel B W "Designing for Production." Edwin Homewood Illinois.
2. Bralla J G (Ed.), "Handbook of Product Design for Manufacture, McGraw Hill, New York, 1986
3. D. T. Pham, S.S. Dimov, Rapid Manufacturing-The Technologies and Applications of Rapid Prototyping and Rapid Tooling, Springer – Verlag, London, 2001.
4. David G Ullman, "The Mechanical Design Process." McGraw Hill Inc Singapore 1992
5. Hollins B & Pugh S "Successful Product Design." Butter worths London, 1990
6. Jones J C "Design Methods." Seeds of Human Futures. John Willey, 1970
7. Kevin Otto & Kristin Wood Product Design: "Techniques in Reverse Engineering and new Product Development.", Pearson Education New Delhi, 2000
8. N J M Roozenberg , J Ekels , N F M Roozenberg " Product Design Fundamentals and Methods ." John Willey & Sons 1995.
9. Andreas Gebhardt, Rapid Prototyping, Carl Hanser – Verlag, Munich, 2003.

## Course Contents and Lecture Schedule

No	Topic	No. of Lectures
1	Module 1	6
1.1	Introduction: Classification/ Specifications of Products. Product life cycle.	2
1.2	Product mix. Introduction to product design. Modern product development process.	2
1.3	Innovative thinking. Morphology of design. Ethics in product design Ethics in product design	2
2	Module 2	6
2.1	Creativity Techniques, Conceptual Design: Generation, selection & embodiment of concept.	2
2.2	Product architecture. Industrial design: process, need.	2
2.3	Robust Design: Taguchi Designs & DOE.	2
3	Module 3	7
3.1	Design for Manufacturing and Assembly: Methods of designing for Manufacturing and Assembly.	3
3.2	Designs for Maintainability. Designs for Environment. Product costing.	2
3.3	Ergonomics in product design. Aesthetics in product design.	2
4	Module 4	7
4.1	Value Engineering / Value Analysis: Definition. Methodology,	3
4.2	Case studies.	2
4.3	Economic analysis: Qualitative & Quantitative. Product costing.	2
5	Module 5	9
5.1	Concurrent Engineering, Rapid prototyping: concepts, processes and advantages.	3
5.2	Reverse engineering: steps in reverse engineering- hardware and software in reverse engineering	2
5.3	Tools for product design – Drafting / Modelling software.	2
5.4	Patents & IP Acts. Overview, Disclosure preparation.	2



COURSE CODE	COURSE NAME	CATEGORY	L	T	P	CREDITS
22MEE604.7	ADVANCED METAL JOINING TECHNIQUES	PROGRAM ELECTIVE 1	2	1	0	3

**Preamble:**

This course provides student to learn fundamental concepts of advanced welding techniques and their applications to an extent to enable the learner to arrive at a firsthand conclusion on selection of a particular technique best suited to resolve a metal joining problem.

Prerequisite: MET204 Manufacturing process.

Course Outcomes: After the completion of the course the student will be able to:

CO 1	Explain the physics, equipment, applications of EBW and LBW.
CO 2	Summarise the physics, equipment, applications of diffusion welding and adhesive bonding processes.
CO 3	Contrast the physics, equipment, applications of explosive welding with friction welding.
CO 4	Outline the physics, equipment, applications of ultrasonic welding and brazing.
CO 5	Illustrate the physics, equipment, applications of plasma arc welding and magnetically impelled arc butt welding.
CO 6	Select an appropriate welding technique to resolve a metal joining problem.

**Mapping of course outcomes with program outcomes:**

	PO 1	PO 2	PO 3	PO 4	PO 5	PO 6	PO 7	PO 8	PO 9	PO 10	PO 11	PO 12
CO 1	3	-	-	-	-	-	-	-	-	-	-	2
CO 2	2	-	-	-	-	-	-	-	-	-	-	2
CO 3	2	-	-	2	-	-	-	-	-	-	-	3
CO 4	3	-	2	-	-	-	-	-	-	-	-	2
CO 5	2	-	-	-	1	-	-	-	-	-	-	2
CO 6	3	-	-	-	2	-	-	-	-	-	-	1

**Assessment Pattern**

Bloom's Category	Continuous Assessment Tests		End Semester Examination (marks)
	1 (marks)	2 (marks)	
Remember	20	20	40
Understand	20	20	40
Apply	10	10	20
Analyse	-	-	-
Evaluate	-	-	-
Create	-	-	-

## Mark distribution

Total Marks	CIE	ESE	ESE Duration
150	50	100	3 hours

### Continuous Internal Evaluation Pattern:

Attendance : 10 marks

Continuous Assessment Test (2 numbers) : 25 marks

Assignment/Quiz/Course project : 15 marks

End Semester Examination Pattern: There will be two parts; Part A and Part B. Part A contain 10 questions with 2 questions from each module, having 3 marks for each question. Students should answer all questions. Part B contains 2 questions from each module of which student should answer any one. Each question can have maximum 2 sub-divisions and carry 14 marks.

### Course Level Assessment Questions.

#### Course Outcome 1 (CO1):

1. Explain principle of operation of Electron Beam Welding.
2. Illustrate a typical EBW gun.
3. List 2 applications of laser beam welding. Identify the inherent process capability of LBM which makes it suitable for above listed applications.

#### Course Outcome 2 (CO2):

1. With the help of suitable diagrams, describe various stages in diffusion welding process.
2. Describe various diffusion welding methods.
3. Explain the physics of adhesive bonding.

#### Course Outcome 3 (CO3):

1. With the help of suitable diagram, describe parallel stand-off and angular stand-off.
2. Compare the mechanism of metal joining in explosive welding with that of friction welding. Give one application for each.
3. Show the effect of rotational speed on duration of friction welding.

#### Course Outcome 4 (CO4):

1. Describe principle of operation of ultrasonic welding.
2. List all design considerations for a brazed joint.

3. Make a note on hand torch brazing.

Course Outcome 5 (CO5):

1. Differentiate transferred and non-transferred plasma arc processes.
2. Sketch and explain a plasma arc welding system.
3. Describe the steps involved in MIAB with appropriate diagrams.

Course Outcome 6 (CO6):

1. Select a welding process which is considered relatively best for underwater welding. Correlate relevant process capability of the selected technique to support your selection.
2. Select a welding process that is considered best for welding stainless steel. Correlate relevant process capability of the selected technique to support your selection.
3. Suggest a best welding technique to join materials having thin sections. Explain why.

Model Question Paper  
SIXTH SEMESTER MECHANICAL ENGINEERING

MET372 ADVANCED METAL JOINING TECHNIQUES

Max. Marks: 100

Duration: 3 hours

Part–A

Answer all questions. Each question carries 3 marks.

1. Draw typical joint designs for electron beam welding.
2. How do you define “f number” for a laser beam?
3. What is vacuum fusion bonding?
4. Write a short note on crack extension test performed on adhesive bonds.
5. What is Impact velocity? How critical is it in creating an explosive weld?
6. Sketch and mark a simple friction welding setup.
7. What is principle of operation of ultrasonic welding?
8. List down essential properties of brazing filler metals.
9. What is “keyholing” in plasma arc welding?
10. What are the advantages of magnetically impelled arc butt welding?

Part–B

Answer one full question from each module.

Module I

11. (a) Draw and explain an EBW equipment. (7 marks)  
(b) Discuss all joint configurations commonly used for LBW. (7 marks)

12. (a) Discuss process characteristics of EBW. (7 marks)  
(b) Discuss Carbon Dioxide lasers used for welding. (7 marks)

#### Module II

13. Explain the theory of diffusion welding process. (14 marks)
14. Classify adhesives used for adhesive bonding and explain their characteristics. (14 marks)

#### Module III

15. With the help of a neat diagram describe different stages in explosion welding. (14 marks)
16. Draw and explain various joint designs employed in friction welding. (14 marks)

#### Module IV

17. State and explain all variables in ultrasonic welding. (14 marks)
18. Write short notes on (i) torch brazing (ii) furnace brazing (iii) vacuum brazing (14 marks)

#### Module V

19. Explain the principle of operation of MIAB welding and steps involved in it with the help of suitable diagrams. (14 marks)
20. Describe the components of a Plasma Arc Welding system and list all applications of PAW. (14 marks)

### Syllabus

#### Module 1

Radiant energy welding: Electron Beam Welding (EBW) - principle and theory- equipment and systems- process characteristics and variables- weld joint design- applications- EBW process variants. Laser Beam Welding-principle and theory-operation-types of lasers-process variables and characteristics-applications.

## Module 2

Diffusion welding-principle and theory-methods- welding parameters-advantages and limitations-applications. Cold pressure welding-process, equipment and set-up-applications. Adhesive Bonding-principle and theory-types of adhesives-joint design-bonding methods- applications.

## Module 3

Explosive welding-principle and theory-process variables-equipment-joint design-advantages and limitations-applications. Friction welding-principle and theory-process variables-advantages and limitations-applications. Friction stir welding- metal flow phenomena-tools-process variables – applications.

## Module 4

Ultrasonic welding-principle and theory-process variables and equipment-types of ultrasonic welds-advantages and limitations-applications. Brazing- principle- brazing processes-torch brazing- furnace brazing- vacuum brazing-induction brazing-advantages and limitations-applications.

## Module 5

Plasma arc welding –principle and theory- transferred arc and non-transferred arc techniques-equipment-advantages and limitations-applications. Magnetically impelled arc butt (MIAB) welding-principle of operation-applications. Under water welding-wet and dry under water welding- set-up for underwater welding systems.

## Text Books

1. Parmar R.S., Welding Processes and Technology, Khanna Publishers, Delhi, 1998.

## Reference Books

1. ASM Metals Handbook “Welding and Brazing”, Vol.6, ASM, Ohio, 1988
2. Parmar R.S., “Welding Engineering and Technology” Khanna Publishers, Delhi, 1997
3. Rossi, B.E., Welding Engineering, Mc Graw-Hill, 1954
4. Schwartz M.M., “Metal Joining Manual”, McGraw-Hill Inc., 1979
5. Udin et al., Welding for Engineers, John Wiley & Sons, New York, 1967
6. Welding Engineers Handbook – ASHE Vol. I, II, III, IV

## Course Contents and Lecture Schedule

No.	Topic	No. of Lectures	COs
1.1	Radiant energy welding: Principle of Electron Beam Welding and theory.	1	CO1
1.2	Types of EBW welding guns.	1	CO1
1.3	EBW equipment and systems.	1	CO1
1.4	Process variables –effect of beam current on weld penetration-effect of	1	CO1

	welding speed on weld penetration.		
1.5	Process variants of EBW-medium vacuum EBW and non-vacuum EBW.	1	CO1
1.6	Typical weld joint design and preparation for EBW.	1	CO1
1.7	Weldable materials using EBW and applications of EBW.	1	CO1CO6
1.8	Principle of Laser Beam Welding, mechanism and operation- types of laser systems- process variables and characteristics.	1	CO1
1.9	Weld joint design – weldable materials and applications of laser beam welding.	1	CO1 CO6
2.1	Diffusion welding- principle and theory.	1	CO2
2.2	Diffusion welding methods- Gas-pressure bonding, Vacuum fusion bonding, Eutectic fusion bonding.	1	CO2
2.3	Diffusion welding parameters.	1	CO2
2.4	Weldable materials using diffusion welding- advantages, limitations and applications.	1	CO2 CO6
2.5	Cold pressure welding equipment and set-up-applications.	1	CO2
2.6	Adhesive bonding- principle and theory- classification of adhesives and types of adhesive materials.	1	CO2
2.7	Joint design and bonding methods – applications.	1	CO2 CO6
3.1	Explosive welding- principle and theory- process variables.	1	CO3
3.2	Set-up for explosion welding- Joint design- advantages and limitations- applications.	1	CO3
3.3	Friction welding- principle and theory- process variables.	2	CO3
3.4	Effect of rotational speed on duration of welding- process characteristics.	1	CO3
3.5	Advantages and limitations-applications. Variants of friction welding- friction stir welding-metal flow phenomena.	2	CO3 CO6
4.1	Ultrasonic welding- principle and theory.	1	CO4
4.2	Ultrasonic process variables and equipment-types of ultrasonic welds.	1	CO4
4.3	Advantages and disadvantages of ultrasonic welding- applications.	1	CO4 CO6
4.4	Brazing-principle-brazing processes- torch brazing- furnace brazing- vacuum brazing-induction brazing-advantages and limitations- applications.	2	CO4
5.1	Plasma Arc welding –principle and theory- transferred arc and non-transferred arc processes.	1	CO5
5.2	Plasma arc welding system.	1	CO5
5.3	Advantages, limitations and applications.	1	CO5 CO6
5.4	Magnetically Impelled Arc Butt (MIAB) welding- principle of operation-applications.	2	CO5 CO6
5.5	Under water welding techniques – wet and dry welding- general arrangement for underwater welding systems.	2	CO5

COURSE CODE	COURSE NAME	CATEGORY	L	T	P	CREDITS
22HUT605	INDUSTRIAL ECONOMICS AND FOREIGN TRADE	HU	3	0	0	3

Preamble: To equip the students to take industrial decisions and to create awareness of economic environment.

Prerequisite: Nil

Course Outcomes: After the completion of the course the student will be able to

CO1	Explain the problem of scarcity of resources and consumer behaviour, and to evaluate the impact of government policies on the general economic welfare. (Cognitive knowledge level: Understand)
CO2	Take appropriate decisions regarding volume of output and to evaluate the social cost of production. (Cognitive knowledge level: Apply)
CO3	Determine the functional requirement of a firm under various competitive conditions. (Cognitive knowledge level: Analyse)
CO4	Examine the overall performance of the economy, and the regulation of economic fluctuations and its impact on various sections in the society. (Cognitive knowledge level: Analyse)
CO5	Determine the impact of changes in global economic policies on the business opportunities of a firm. (Cognitive knowledge level: Analyse)

Mapping of course outcomes with program outcomes

	PO1	PO2	PO3	PO4	PO5	PO6	PO7	PO8	PO9	PO10	PO11	PO12
CO1	2										3	
CO2	2	2			2	2	3				3	
CO3	2	2	1								3	
CO4	2	2	1			1					3	
CO5	2	2	1								3	

Abstract POs defined by National Board of Accreditation			
PO#	Broad PO	PO#	Broad PO
PO1	Engineering Knowledge	PO7	Environment and Sustainability
PO2	Problem Analysis	PO8	Ethics
PO3	Design/Development of solutions	PO9	Individual and team work
PO4	Conduct investigations of complex problems	PO10	Communication
PO5	Modern tool usage	PO11	Project Management and Finance
PO6	The Engineer and Society	PO12	Lifelong learning

#### Assessment Pattern

Bloom's Category	Continuous Assessment Tests		End Semester Examination Marks
	Test 1 (Marks)	Test 2 (Marks)	
Remember	15	15	30
Understand	20	20	40
Apply	15	15	30

#### Mark Distribution

Total Marks	CIE Marks	ESE Marks	ESE Duration
150	50	100	3 hours



#### Continuous Internal Evaluation Pattern:

Attendance	: 10 marks
Continuous Assessment - Test (2 numbers)	: 25 marks
Continuous Assessment - Assignment	: 15 marks

#### Internal Examination Pattern:

Each of the two internal examinations has to be conducted out of 50 marks. First series test shall be preferably conducted after completing the first half of the syllabus and the second series test shall be preferably conducted after completing remaining part of the syllabus. There will be two parts: Part A and Part B. Part A contains 5 questions (preferably, 2 questions each from the completed modules and 1 question from the partly completed module), having 3 marks for each question adding up to 15 marks for part A. Students should answer all questions from Part A. Part B contains 7 questions (preferably, 3 questions each from the completed modules and 1 question from the partly completed module), each with 7 marks. Out of the 7 questions, a student should answer any 5.

#### End Semester Examination Pattern:

There will be two parts; Part A and Part B.

Part A : 30 marks

Part B : 70 marks

Part A contains 10 questions with 2 questions from each module, having 3 marks for each question. Students should answer all questions. Part B contains 2 questions from each module of which a student should answer any one. Each question can have maximum 3 sub-divisions and carries 14 marks.

## SYLLABUS

### HUT 300 Industrial Economics & Foreign Trade

#### Module 1 (Basic Concepts and Demand and Supply Analysis)

Scarcity and choice - Basic economic problems- PPC – Firms and its objectives – types of firms – Utility – Law of diminishing marginal utility – Demand and its determinants – law of demand – elasticity of demand – measurement of elasticity and its applications – Supply, law of supply and determinants of supply – Equilibrium – Changes in demand and supply and its effects – Consumer surplus and producer surplus (Concepts) – Taxation and deadweight loss.

#### Module 2 (Production and cost)

Production function – law of variable proportion – economies of scale – internal and external economies – Isoquants, isocost line and producer's equilibrium – Expansion path – Technical progress and its implications – Cobb-Douglas production function - Cost concepts – Social cost: private cost and external cost – Explicit and implicit cost – sunk cost - Short run cost curves - long run cost curves – Revenue (concepts) – Shutdown point – Break-even point.

#### Module 3 (Market Structure)

Perfect and imperfect competition – monopoly, regulation of monopoly, monopolistic completion (features and equilibrium of a firm) – oligopoly – Kinked demand curve – Collusive oligopoly (meaning) – Non-price competition – Product pricing – Cost plus pricing – Target return pricing – Penetration pricing – Predatory pricing – Going rate pricing – Price skimming.

#### Module 4 (Macroeconomic concepts)

Circular flow of economic activities – Stock and flow – Final goods and intermediate goods - Gross Domestic Product - National Income – Three sectors of an economy- Methods of measuring national income – Inflation- causes and effects – Measures to control inflation- Monetary and fiscal policies – Business financing- Bonds and shares -Money market and Capital market – Stock market – Demat account and Trading account - SENSEX and NIFTY.

#### Module 5 (International Trade)

Advantages and disadvantages of international trade - Absolute and Comparative advantage theory - Heckscher - Ohlin theory - Balance of payments – Components – Balance of Payments

deficit and devaluation – Trade policy – Free trade versus protection – Tariff and non-tariff barriers.

#### Reference Materials

1. Gregory N Mankiw, 'Principles of Micro Economics', Cengage Publications
2. Gregory N Mankiw, 'Principles of Macro Economics', Cengage Publications
3. Dwivedi D N, 'Macro Economics', Tata McGraw Hill, New Delhi.
4. Mithani D M, 'Managerial Economics', Himalaya Publishing House, Mumbai.
5. Francis Cherunilam, 'International Economics', McGraw Hill, New Delhi.

#### Sample Course Level Assessment Questions

##### Course Outcome 1 (CO1):

1. Why does the problem of choice arise?
2. What are the central problems?
3. How do we solve the basic economic problems?
4. What is the relation between price and demand?
5. Explain deadweight loss due to the imposition of a tax.

##### Course Outcome 2 (CO2):

1. What is shutdown point?
2. What do you mean by producer equilibrium?
3. Explain break-even point;
4. Suppose a chemical factory is functioning in a residential area. What are the external costs?

##### Course Outcome 3 (CO3):

1. Explain the equilibrium of a firm under monopolistic competition.
2. Why is a monopolist called price maker?
3. What are the methods of non-price competition under oligopoly?

4. What is collusive oligopoly?

Course Outcome 4 (CO4):

1. What is the significance of national income estimation?
2. How is GDP estimated?
3. What are the measures to control inflation?
4. How does inflation affect fixed income group and wage earners?

Course Outcome 5 (CO5):

1. What is devaluation?
2. Suppose a foreign country imposes a tariff on Indian goods. How does it affect India's exports?
3. What is free trade?
4. What are the arguments in favour of protection?

Model Question paper

QP CODE:

PAGES:3

Reg No: \_\_\_\_\_

Name : \_\_\_\_\_

B.TECH DEGREE EXAMINATION, MONTH & YEAR

Course Code: HUT 300

Course Name: Industrial Economics & Foreign Trade

Max.Marks:100

Duration: 3 Hours

PART A

Answer all Questions. Each question carries 3 Marks

1. Why does an economic problem arise?
2. What should be the percentage change in price of a product if the sale is to be increased by 50 percent and its price elasticity of demand is 2?
3. In the production function  $Q = 2L^{1/2}K^{1/2}$  if  $L=36$  how many units of capital are needed to produce 60 units of output?
4. Suppose in the short run  $AVC < P < AC$ . Will this firm produce or shut down? Give reason.
5. What is predatory pricing?
6. What do you mean by non- price competition under oligopoly?
7. What are the important economic activities under primary sector?
8. Distinguish between a bond and share?
9. What are the major components of balance of payments?

10. What is devaluation?

(10 x 3 = 30 marks)

### PART B

(Answer one full question from each module, each question carries 14 marks)

#### MODULE I

11. a) Prepare a utility schedule showing units of consumption, total utility and marginal utility, and explain the law of diminishing marginal utility. Point out any three limitations of the law.

b) How is elasticity of demand measured according to the percentage method? How is the measurement of elasticity of demand useful for the government?

Or

12. a) Explain the concepts consumer surplus and producer surplus.

b) Suppose the government imposes a tax on a commodity where the tax burden is met by the consumers. Draw a diagram and explain dead weight loss. Mark consumer surplus, producer surplus, tax revenue and dead weight loss in the diagram.

#### MODULE II

13. a) What are the advantages of large-scale production?

b) Explain Producer equilibrium with the help of isoquants and isocost line. What is expansion path?

Or

14. a) Explain break-even analysis with the help of a diagram.

b) Suppose the monthly fixed cost of a firm is Rs. 40000 and its monthly total variable cost is Rs. 60000.

i. If the monthly sales is Rs. 120000 estimate contribution and break-even sales.

ii. If the firm wants to get a monthly profit of Rs.40000, what should be the sales?

c) The total cost function of a firm is given as  $TC=100+50Q - 11Q^2+Q^3$ . Find marginal cost when output equals 5 units.

#### MODULE III

15. a) What are the features of monopolistic competition?

b) Explain the equilibrium of a firm earning supernormal profit under monopolistic competition.

Or

16.a) Make comparison between perfect competition and monopoly.

b) Explain price rigidity under oligopoly with the help of a kinked demand curve.

#### MODULE IV

17. a) How is national income estimated under product method and expenditure method?

b) Estimate GDPmp, GNPmp and National income

Private consumption expenditure	= 2000 (in 000 cores)
Government Consumption	= 500
NFIA	= -(300)
Investment	= 800
Net=exports	=700
Depreciation	= 400
Net-indirect tax	= 300

Or

18. a) What are the monetary and fiscal policy measures to control inflation?

b) What is SENSEX?

#### MODULE V

19. a) What are the advantages of disadvantages of foreign trade?

b) Explain the comparative cost advantage.

Or

20. a) What are the arguments in favour protection?

b) Examine the tariff and non-tariff barriers to international trade.

(5 × 14 = 70 marks)

### Teaching Plan

Module 1 (Basic concepts and Demand and Supply Analysis)		7 Hours
1.1	Scarcity and choice – Basic economic problems - PPC	1 Hour
1.2	Firms and its objectives – types of firms	1 Hour
1.3	Utility – Law of diminishing marginal utility – Demand – law of demand	1 Hour
1.4	Measurement of elasticity and its applications	1 Hour
1.5	Supply, law of supply and determinants of supply	1 Hour
1.6	Equilibrium – changes in demand and supply and its effects	1 Hour
1.7	Consumer surplus and producer surplus (Concepts) – Taxation and deadweight loss.	1 Hour
Module 2 (Production and cost)		7 Hours
2.1	Productions function – law of variable proportion	1 Hour
2.2	Economies of scale – internal and external economies	1 Hour
2.3	producers equilibrium – Expansion path	1 Hour
2.4	Technical progress and its implications – cob Douglas Production function	1 Hour
2.5	Cost concepts – social cost: private cost and external cost – Explicit and implicit cost – sunk cost	1 Hour
2.6	Short run cost curves & Long run cost curves	1 Hour
2.7	Revenue (concepts) – shutdown point – Break-even point.	1 Hour
Module 3 (Market Structure)		6 hours
3.1	Equilibrium of a firm, MC – MR approach and TC – TR approach	1 Hour
3.2	Perfect competition & Imperfect competition	1 Hour
3.3	Monopoly – Regulation of monopoly – Monopolistic competition	1 Hour
3.4	Oligopoly – kinked demand curve	1 Hour
3.5	Collusive oligopoly (meaning) – Non price competition	1 Hour
3.6	Cost plus pricing – Target return pricing – Penetration, Predatory pricing – Going rate pricing – price skimming	1 Hour



Module 4 (Macroeconomic concepts)		7 Hours
4.1	Circular flow of economic activities	1 Hour
4.2	Stock and flow – Final goods and intermediate goods – Gross Domestic Product - National income – Three sectors of an economy	1 Hour
4.3	Methods of measuring national income	1 Hour
4.4	Inflation – Demand pull and cost push – Causes and effects	1 Hour
4.5	Measures to control inflation – Monetary and fiscal policies	1 Hour
4.6	Business financing – Bonds and shares – Money market and capital market	1 Hour
4.7	Stock market – Demat account and Trading account – SENSEX and NIFTY	1 Hour
Module 5 (International Trade)		8 Hours
5.1	Advantages and disadvantages of international trade	1 Hour
5.2	Absolute and comparative advantage theory	2 Hour
5.3	Heckscher – Ohlin theory	1 Hour
5.4	Balance of payments - components	1 Hour
5.5	Balance of payments deficit and devaluation	1 Hour
5.6	Trade policy – Free trade versus protection	1 Hour
5.7	Tariff and non tariff barriers.	1 Hour

COURSE CODE	COURSE NAME	CATEGORY	L	T	P	CREDITS
22HUT606	MANAGEMENT FOR ENGINEERS	HU	3	0	0	3

Preamble: This course is intended to help the students to learn the basic concepts and functions of management and its role in the performance of an organization and to understand various decision-making approaches available for managers to achieve excellence. Learners shall have a broad view of different functional areas of management like operations, human resource, finance and marketing.

Prerequisite: Nil

Course Outcomes After the completion of the course the student will be able to

CO1	Explain the characteristics of management in the contemporary context (Cognitive Knowledge level: Understand).
CO2	Describe the functions of management (Cognitive Knowledge level: Understand).
CO3	Demonstrate ability in decision making process and productivity analysis (Cognitive Knowledge level: Understand).
CO4	Illustrate project management technique and develop a project schedule (Cognitive Knowledge level: Apply).
CO5	Summarize the functional areas of management (Cognitive Knowledge level: Understand).
CO6	Comprehend the concept of entrepreneurship and create business plans (Cognitive Knowledge level: Understand).

Mapping of course outcomes with program outcomes

	PO1	PO2	PO3	PO4	PO5	PO6	PO7	PO8	PO9	PO10	PO11	PO12
CO1	2				1	2	2	2		2	1	1
CO2	2				1	1		2	1	2	1	1
CO3	2	2	2	2	1							
CO4	2	2	2	2	1						2	1
CO5	2					1	1		1	2	1	
CO6		2	2	2	1	1	1	1	1	1	1	1

Abstract POs defined by National Board of Accreditation				
PO1	Engineering Knowledge		PO7	Environment and Sustainability
PO2	Problem Analysis		PO8	Ethics
PO3	Design/Development of solutions		PO9	Individual and team work
PO4	Conduct investigations of complex problems		PO10	Communication
PO5	Modern tool usage		PO11	Project Management and Finance
PO6	The Engineer and Society		PO12	Life long learning

Assessment Pattern

Bloom's Category	Test 1 (Marks in percentage)	Test 2 (Marks in percentage)	End Semester Examination (Marks in percentage)
Remember	15	15	30
Understand	15	15	30
Apply	20	20	40
Analyse			
Evaluate			
Create			

## Mark Distribution

Total Marks	CIE Marks	ESE Marks	ESE Duration
150	50	100	3 Hours

### Continuous Internal Evaluation Pattern:

Attendance : 10 marks

Continuous Assessment - Test : 25 marks

Continuous Assessment - Assignment : 15 marks

### Internal Examination Pattern:

Each of the two internal examinations has to be conducted out of 50 marks. First series test shall be preferably conducted after completing the first half of the syllabus and the second series test shall be preferably conducted after completing remaining part of the syllabus. There will be two parts: Part A and Part B. Part A contains 5 questions (preferably, 2 questions each from the completed modules and 1 question from the partly completed module), having 3 marks for each question adding up to 15 marks for part A. Students should answer all questions from Part A. Part B contains 7 questions (preferably, 3 questions each from the completed modules and 1 question from the partly completed module), each with 7 marks. Out of the 7 questions, a student should answer any 5.

### End Semester Examination Pattern:

There will be two parts; Part A and Part B. Part A contains 10 questions with 2 questions from each module, having 3 marks for each question. Students should answer all questions. Part B contains 2 questions from each module of which a student should answer any one. Each question can have maximum 2 sub-divisions and carries 14 marks.

## SYLLABUS

HUT 310 Management for Engineers (35 hrs)

### Module 1 (Introduction to management Theory- 7 Hours)

Introduction to management theory, Management Defined, Characteristic of Management, Management as an art-profession, System approaches to Management, Task and Responsibilities of a professional Manager, Levels of Manager and Skill required.

### Module 2 (management and organization- 5 hours)

Management Process, Planning types , Mission, Goals, Strategy, Programmes, Procedures, Organising, Principles of Organisation, Delegation, Span of Control, Organisation Structures, Directing, Leadership, Motivation, Controlling..

### Module 3 (productivity and decision making- 7 hours)

Concept of productivity and its measurement; Competitiveness; Decision making process; decision making under certainty, risk and uncertainty; Decision trees; Models of decision making.

### . Module 4 (project management- 8 hours)

Project Management, Network construction, Arrow diagram, Redundancy. CPM and PERT Networks, Scheduling computations, PERT time estimates, Probability of completion of project, Introduction to crashing.

### Module 5 (functional areas of management- 8 hours)

Introduction to functional areas of management, Operations management, Human resources management, Marketing management, Financial management, Entrepreneurship, Business plans, Corporate social responsibility, Patents and Intellectual property rights.

References:

1. H. Koontz, and H. Weihrich, Essentials of Management: An International Perspective. 8th ed., McGraw-Hill, 2009.
2. P C Tripathi and P N Reddy, Principles of management, TMH, 4<sup>th</sup> edition, 2008.
3. P. Kotler, K. L. Keller, A. Koshy, and M. Jha, Marketing Management: A South Asian Perspective. 14th ed., Pearson, 2012.
4. M. Y. Khan, and P. K. Jain, Financial Management, Tata-McGraw Hill, 2008.
5. R. D. Hisrich, and M. P. Peters, Entrepreneurship: Strategy, Developing, and Managing a New Enterprise, 4th ed., McGraw-Hill Education, 1997.
6. D. J. Sumanth, Productivity Engineering and Management, McGraw-Hill Education, 1985.
7. K.Ashwathappa, 'Human Resources and Personnel Management', TMH, 3<sup>rd</sup> edition, 2005.
8. R. B. Chase, Ravi Shankar and F. R. Jacobs, Operations and Supply Chain Management, 14th ed. McGraw Hill Education (India), 2015.

#### Sample Course Level Assessment Questions

Course Outcome1 (CO1): Explain the systems approach to management?

Course Outcome 2 (CO2): Explain the following terms with a suitable example Goal, Objective, and Strategy.

Course Outcome 3 (CO3): Mr. Shyam is the author of what promises to be a successful novel. He has the option to either publish the novel himself or through a publisher. The publisher is offering Mr. Shyam Rs. 20,000 for signing the contract. If the novel is successful, it will sell 200,000 copies. Else, it will sell 10,000 copies only. The publisher pays a Re. 1 royalty per copy. A market survey indicates that there is a 70% chance that the novel will be successful. If Mr. Shyam undertakes publishing, he will incur an initial cost of Rs. 90,000 for printing and marketing., but each copy sold will net him Rs. 2. Based on the given information and the

decision analysis method, determine whether Mr. Shyam should accept the publisher's offer or publish the novel himself.

Course Outcome 4 (CO4): Explain the concepts of crashing and dummy activity in project management.

Course Outcome 5 (CO5): Derive the expression for the Economic order quantity (EOQ)?

Course Outcome 6 (CO6): Briefly explain the theories of Entrepreneurial motivation.?

Model Question Paper

QP CODE:

PAGES: 4

Reg No: \_\_\_\_\_

Name: \_\_\_\_\_

APJ ABDUL KALAM TECHNOLOGICAL UNIVERSITY  
FOURTH SEMESTER B.TECH DEGREE EXAMINATION, MONTH & YEAR

Course Code: HUT 310

Course name: Management for Engineers

Max Marks: 100

Duration: 3 Hours

PART-A (Answer All Questions. Each question carries 3 marks)

1. "Management is getting things done through other." Elaborate.
2. Comment on the true nature of management. Is it a science or an art?
3. Planning is looking ahead and controlling is looking back. Comment with suitable examples
4. Explain the process of communication?
5. Explain the hierarchy of objectives?
6. Explain the types of decisions?
7. Describe the Economic man model?
8. Explain the concepts of crashing and dummy activity in project management.
9. Differentiate the quantitative and qualitative methods in forecasting.
10. What are the key metrics for sustainability measurement? What makes the measurement and reporting of sustainability challenging?

PART-B (Answer any one question from each module)

11. a) Explain the systems approach to management. (10)  
b) Describe the roles of a manager (4)

OR



12. a) Explain the 14 principles of administrative management? (10)

b) Explain the different managerial skills (4)

13. a) What are planning premises, explain the classification of planning premises. (10)

b) Distinguish between strategy and policy. How can policies be made effective. (4)

OR

14 a) Explain three motivational theories. (9)

b) Describe the managerial grid. (5)

15. a) Modern forest management uses controlled fires to reduce fire hazards and to stimulate new forest growth. Management has the option to postpone or plan a burning. In a specific forest tract, if burning is postponed, a general administrative cost of Rs. 300 is incurred. If a controlled burning is planned, there is a 50% chance that good weather will prevail and burning will cost Rs. 3200. The results of the burning may be either successful with probability 0.6 or marginal with probability 0.4. Successful execution will result in an estimated benefit of Rs. 6000, and marginal execution will provide only Rs. 3000 in benefits. If the weather is poor, burning will be cancelled incurring a cost of Rs. 1200 and no benefit. i) Develop a decision tree for the problem. (ii) Analyse the decision tree and determine the optimal course of action. (8)

b) Student tuition at ABC University is \$100 per semester credit hour. The Education department supplements the university revenue by matching student tuition, dollars per dollars. Average class size for typical three credit course is 50 students. Labour costs are \$4000 per class, material costs are \$20 per student, and overhead cost are \$25,000 per class. (a) Determine the total factor productivity. (b) If instructors deliver lecture 14 hours per week and the semester lasts for 16 weeks, what is the labour productivity? (6)

OR

16. a) An ice-cream retailer buys ice cream at a cost of Rs. 13 per cup and sells it for Rs. 20 per cup; any remaining unsold at the end of the day, can be disposed at a salvage price of Rs. 2.5 per cup. Past sales have ranged between 13 and 17 cups per day; there is no reason to believe that

sales volume will take on any other magnitude in future. Find the expected monetary value and EOL, if the sales history has the following probabilities:  
(9)

Market Size	13	14	15	16	17
Probability	0.10	0.15	0.15	0.25	0.35

b) At Modern Lumber Company, Kishore the president and a producer of an apple crates sold to growers, has been able, with his current equipment, to produce 240 crates per 100 logs. He currently purchases 100 logs per day, and each log required 3 labour hours to process. He believes that he can hire a professional buyer who can buy a better quality log at the same cost. If this is the case, he increases his production to 260 crates per 100 logs. His labour hours will increase by 8 hours per day. What will be the impact on productivity (measured in crates per labour-hour) if the buyer is hired? What is the growth in productivity in this case?  
(5)

17. a) A project has the following list of activities and time estimates:

Activity	Time (Days)	Immediate Predecessors
A	1	-
B	4	A
C	3	A
D	7	A
E	6	B
F	2	C, D
G	7	E, F
H	9	D
I	4	G, H

(a) Draw the network. (b) Show the early start and early finish times. (c) Show the critical path.  
(10)

b) An opinion survey involves designing and printing questionnaires, hiring and training personnel, selecting participants, mailing questionnaires and analysing data. Develop the precedence relationships and construct the project network. (4)

OR

18. a) The following table shows the precedence requirements, normal and crash times, and normal and crash costs for a construction project:

Activity	Immediate Predecessors	Required Time (Weeks)		Cost (Rs.)	
		Normal	Crash	Normal	Crash
A	-	4	2	10,000	11,000
B	A	3	2	6,000	9,000
C	A	2	1	4,000	6,000
D	B	5	3	14,000	18,000
E	B, C	1	1	9,000	9,000
F	C	3	2	7,000	8,000
G	E, F	4	2	13,000	25,000
H	D, E	4	1	11,000	18,000
I	H, G	6	5	20,000	29,000

Draw the network. (b) Determine the critical path. (c) Determine the optimal duration and the associated cost. (10)

b) Differentiate between CPM and PERT. (4)

19. a) What is meant by market segmentation and explain the process of market segmentation (8)

b) The Honda Co. in India has a division that manufactures two-wheel motorcycles. Its budgeted sales for Model G in 2019 are 80,00,000 units. Honda's target ending inventory is 10,00,000 units and its beginning inventory is 12,00,000 units. The company's budgeted selling price to its distributors and dealers is Rs. 40,000 per motorcycle. Honda procures all its wheels from an

outside supplier. No defective wheels are accepted. Honda's needs for extra wheels for replacement parts are ordered by a separate division of the company. The company's target ending inventory is 3,00,000 wheels and its beginning inventory is 2,00,000 wheels. The budgeted purchase price is Rs. 1,600 per wheel.

(a) Compute the budgeted revenue in rupees.

(b) Compute the number of motorcycles to be produced.

Compute the budgeted purchases of wheels in units and in rupees.? (6)

OR

20. a) a) "Human Resource Management policies and principles contribute to effectiveness, continuity and stability of the organization". Discuss. (b) What is a budget? Explain how sales budget and production budgets are prepared? (10)

b) Distinguish between the following: (a) Assets and Liabilities (b) Production concept and Marketing concept (c) Needs and Wants (d) Design functions and Operational control functions in operations (4)

## Teaching Plan

Sl.No	TOPIC	SESSION
	Module I	
1.1	Introduction to management	1
1.2	Levels of managers and skill required	2
1.3	Classical management theories	3
1.4	neo-classical management theories	4
1.5	modern management theories	5
1.6	System approaches to Management,	6
1.7	Task and Responsibilities of a professional Manager	7
	Module 2	
2.1	Management process – planning	8
2.2	Mission – objectives – goals – strategy – policies – programmes – procedures	9
2.3	Organizing, principles of organizing, organization structures	10
2.4	Directing, Leadership	11
2.5	Motivation, Controlling	12
	Module III	
3.1	Concept of productivity and its measurement Competitiveness	13
3.2	Decision making process;	14
3.3	Models in decision making	15
3.4	Decision making under certainty and risk	16
3.5	Decision making under uncertainty	17
3.6	Decision trees	18
3.7	Models of decision making.	19
	Module IV	
4.1	Project Management	20

Sl.No	TOPIC	SESSION
	Module I	
4.2	Network construction	21
4.3	Arrow diagram, Redundancy	22
4.4	CPM and PERT Networks	23
4.5	Scheduling computations	24
4.6	PERT time estimates	25
4.7	Probability of completion of project	26
4.8	Introduction to crashing	
	Module V	
5.1	Introduction to functional areas of management,	28
5.2	Operations management	29
5.3	Human resources management ,	30
5.4	Marketing management	31
5.5	Financial management	32
5.6	Entrepreneurship,	33
5.7	Business plans	34
5.8	Corporate social responsibility, Patents and Intellectual property rights	35

COURSE CODE	COURSE NAME	CATEGORY	L	T	P	CREDITS
22MET607	COMPREHENSIVE COURSE WORK	V	1	0	0	1

Preamble: The course is designed to ensure that the students have firmly grasped the foundational knowledge in Mechanical Engineering familiar enough with the technological concepts. It provides an opportunity for the students to demonstrate their knowledge in various Mechanical Engineering subjects.

Pre-requisite: Nil

Course outcomes: After the course, the student will able to:

CO1	Learn to prepare for a competitive examination
CO2	Comprehend the questions in Mechanical Engineering field and answer them with confidence
CO3	Communicate effectively with faculty in scholarly environments
CO4	Analyze the comprehensive knowledge gained in basic courses in the field of Mechanical Engineering

Mapping of course outcomes with program outcomes:

	PO 1	PO 2	PO 3	PO 4	PO 5	PO 6	PO 7	PO 8	PO 9	PO 10	PO 11	PO 12
CO 1	3	2										2
CO 2	3	2										2
CO 3	3	2										2
CO 4	2	3										2

Assessment pattern

Bloom's Category	End Semester Examination (Marks)
Remember	25
Understand	15
Apply	5

Analyze	5
Evaluate	
Create	

#### End Semester Examination Pattern:

A written examination will be conducted by the University at the end of the sixth semester. The written examination will be of objective type similar to the GATE examination. Syllabus for the comprehensive examination is based on following five Mechanical Engineering core courses.

MET203- MECHANICS OF FLUIDS

MET205- METALLURGY AND MATERIAL SCIENCE

MET202- ENGINEERING THERMODYNAMICS

MET204– MANUFACTURING PROCESS

MET301- MECHANICS OF MACHINERY

The written test will be of 50 marks with 50 multiple choice questions (10 questions from each module) with 4 choices of 1 mark each covering all the five core courses. There will be no negative marking. The pass minimum for this course is 25. The course should be mapped with a faculty and classes shall be arranged for practicing questions based on the core courses listed above.

Written examination: 50marks

Total : 50 marks

#### Course Level Assessment and Sample Questions:

- The shear stress developed in lubricating oil, of viscosity 9.81 poise, filled between two parallel plates 1cm apart and moving with relative velocity of 2 m/s is
  - 20 N/m<sup>2</sup>
  - 19.62 N/m<sup>2</sup>
  - 29.62 N/m<sup>2</sup>
  - 40 N/m<sup>2</sup>
- For a Newtonian fluid
  - Shear stress is proportional to shear strain
  - Rate of shear stress is proportional to shear strain
  - Shear stress is proportional to rate of shear strain



- (d) Rate of shear stress is proportional to rate of shear strain
3. Atomic packing factor (APF) in the case of copper crystal is
- (a) 0.52
  - (b) 0.68
  - (c) 0.74
  - (d) 1.633
4. What is the approximate strain energy expression for a dislocation of unit length, irrespective of its edge or screw character?
- (a)  $G^2b/2$
  - (b)  $Gb^2/2$
  - (c)  $G^2b/4$
  - (d)  $Gb^2/4$
5. Consider the following statements
- 1. Zeroth law of thermodynamics is related to temperature
  - 2. Entropy is related to first law of thermodynamics
  - 3. Internal energy of an ideal gas is a function of temperature and pressure
  - 4. Van der Waals' equation is related to an ideal gas
- Which of the above statements is/are correct?
- (a) 1 only
  - (b) 2, 3 and 4
  - (c) 1 and 3
  - (d) 2 and 4
6. A gas is compressed in a cylinder by a movable piston to a volume one-half of its original volume. During the process, 300 kJ heat left the gas and the internal energy remained same. What is the work done on the gas?
- (a) 100 kNm
  - (b) 150 kNm
  - (c) 200 kNm
  - (d) 300 kNm
7. Which one of the following casting processes is best suited to make bigger size hollow symmetrical pipes?
- (a) Die casting
  - (b) Investment casting
  - (c) Shell moulding
  - (d) Centrifugal casting
8. In gas welding of mild steel using an oxy-acetylene flame, the total amount of acetylene consumed was 10 litre. The oxygen consumption from the cylinder is
- (a) 5 litre
  - (b) 10 litre
  - (c) 15litre
  - (d) 20 litre
9. The number of inversions for a slider crank mechanism is
- ( a ) 6   ( b ) 5   ( c ) 4   ( d ) 3

10. Total number of instantaneous centers for a mechanism with n links are

( a )  $n/2$     ( b )  $n$     ( c )  $(n-1)/2$     ( d )  $(n(n-1))/2$

## Syllabus

### MODULE 1

Fluids and continuum, Physical properties of fluids, Newton's law of viscosity. Ideal and real fluids, Newtonian and non-Newtonian fluids. Fluid Statics- Pressure-density-height relationship, manometers, pressure on plane and curved surfaces, center of pressure, buoyancy, stability of immersed and floating bodies

Kinematics of fluid flow: Eulerian and Lagrangian approaches, classification of fluid flow, stream lines, path lines, streak lines, stream tubes, , stream function and potential function

Equations of fluid dynamics: Differential equations of mass, energy and momentum (Euler's equation), Bernoulli's equation, Pipe Flow: Viscous flow: shear stress and velocity distribution in a pipe Hagen Poiseuille equation. Darcy-Weisbach equation,

### MODULE 2

Development of atomic structure - Primary bonds: - characteristics of covalent, ionic and metallic bond - properties based on atomic bonding Crystallography: - SC, BCC, FCC, HCP structures, APF , Miller Indices: - crystal plane and direction - Modes of plastic deformation: - Slip and twinning

Classification of crystal imperfections - forest of dislocation, role of surface defects on crack initiation- Burgers vector –Frank Read source - Correlation of dislocation density with strength and nano concept - high and low angle grain boundaries– driving force for grain growth and applications

Phase diagrams: - need of alloying - classification of alloys - Hume Rothery's rule – equilibrium diagram of common types of binary systems: five types - Coring - lever rule and Gibb's phase rule - Reactions- Detailed discussion on Iron-Carbon equilibrium diagram with micro structure and properties -Heat treatment: - TTT, CCT diagram, applications - Tempering- Hardenability, Jominy end quench test, applications- Surface hardening methods.

### MODULE 3

Basic Thermodynamic Concepts Macroscopic and Microscopic viewpoints, Concept of Continuum, Thermodynamic System and Control Volume, Surrounding, Boundaries, Types of Systems, Universe, Thermodynamic properties, Process, Cycle, Thermodynamic Equilibrium, Quasi – static Process, State, Point and Path function. Zeroth Law of Thermodynamics, Measurement of Temperature, reference Points, Temperature Scales.

First law of Thermodynamics - First law applied to Non flow and flow Process- SFEE

Second Law of Thermodynamics, Kelvin-Planck and Clausius Statements, Equivalence of two statements Entropy- Entropy changes in various thermodynamic processes, principle of increase of entropy and its applications, Available Energy, Availability and Irreversibility- Second law efficiency.

### MODULE 4

Casting:-Characteristics of sand - patterns- cores- -chapters- simple problems- solidification of metals and Chvorinov's rule - Elements of gating system- risering -chills

Welding:-welding metallurgy-heat affected zone- grain size and hardness- stress relieving- joint quality -heat treatment of welded joints - weldability - destructive and non destructive tests of welded joints Thermit welding, friction welding - Resistance welding, Arc Welding, Oxyacetyline welding

Rolling:- principles - types of rolls and rolling mills - mechanics of flat rolling-Defects-vibration and chatter - flat rolling -miscellaneous rolling process

Forging: methods analysis, applications, die forging, defects in forging

### MODULE 5

Introduction to kinematics and mechanisms - various mechanisms, kinematic diagrams, degree of freedom- Grashof's criterion, inversions, coupler curves mechanical advantage, transmission angle. straight line mechanisms exact, approximate. Displacement, velocity analysis– relative motion - relative velocity. Instantaneous centre -Kennedy's theorem.

Acceleration analysis- Relative acceleration - Coriolis acceleration - graphical and analytical methods.

Cams - classification of cam and followers - displacement diagrams, velocity and acceleration analysis of SHM, uniform velocity, uniform acceleration, cycloidal motion

Graphical cam profile synthesis, pressure angle.

COURSE CODE	COURSE NAME	CATEGORY	L	T	P	CREDITS
22MEL608	COMPUTER AIDED DESIGN & ANALYSIS LAB	ES	0	0	3	2

**Preamble:**

- To introduce students to the basics and standards of engineering design and analysis related to machine components.
- To make students familiarize with different solid modelling and analysis soft wares
- To convey the principles and requirements of modelling and analysis of machine elements.
- To introduce the preparation of part modelling and assembly modelling of machineries
- To introduce standard CAD packages to perform Finite Element Analysis of machine parts

**Prerequisite:**

EST 110 - Engineering Graphics

MEL 201 - Computer Aided Machine Drawing

Course Outcomes - At the end of the course students will be able to

CO1	Gain working knowledge in Computer Aided Design and modelling procedures.
CO2	Gain knowledge in creating solid machinery parts.
CO3	Gain knowledge in assembling machine elements.
CO4	Gain working knowledge in Finite Element Analysis.
CO5	Solve simple structural, heat and fluid flow problems using standard software

**Mapping of course outcomes with program outcomes (Minimum requirements)**

	PO1	PO2	PO3	PO4	PO5	PO6	PO7	PO8	PO9	PO10	PO11	PO12
CO1	3	-	-	-	-	-	-	-	-	2	-	-
CO2	3	-	1	-	-	-	-	-	-	3	-	-
CO3	3	3	-	-	-	-	-	-	2	2	-	-
CO4	3	1	3	-	-	-	-	1	2	3	-	-
CO5	3	3	2	-	-	-	-	2	3	3	-	-

**Mark Distribution**

Total Marks	CIE Marks	ESE marks	ESE duration
150	75	75	2.5 hours

**Continuous Internal Evaluation (CIE) Pattern:**

Attendance	15 marks
Regular class work/Modelling and Analysis/Lab Record and Class Performance	30 marks
Continuous Assessment Test (minimum two tests)	30 marks

### Continuous Assessment test pattern

Bloom's Taxonomy	Continuous Assessment Tests	
	Test 1 - PART A MODELLING (marks)	Test 2 - PART B ANALYSIS (marks)
Remember	10	10
Understand	10	10
Apply	20	20
Analyse	15	15
Evaluate	20	20
Create	25	25

### End semester examination pattern

End semester examination shall be conducted on modelling and analysis and based on complete syllabus. The following general guidelines should be maintained for the award of marks

Part A Assembly Modelling – 35 marks

Part B Analysis – 30 marks

Viva Voce – 10 marks.

### Conduct of University Practical Examinations

The Principals of the concerned Engineering Colleges with the help of the Chairmen/Chairperson will conduct the practical examination with the approval from the University and bonafide work / laboratory record, hall ticket, identity card issued by college are mandatory for appearing practical University examinations. No practical examination should be conducted without the presence of an external examiner appointed by the University.

### References Books:

1. Daryl Logan, A First course in Finite Element Method, Thomson Learning, 2007
2. David V Hutton, Fundamentals of Finite Element Analysis, Tata McGraw Hill, 2003
3. Ibrahim Zeid, CAD/ CAM Theory and Practice, McGraw Hill, 2007
4. Mikell P. Groover and Emory W. Zimmer, CAD/ CAM – Computer aided design and manufacturing, Pearson Education, 1987
5. T. R. Chandrupatla and A. D. Belagundu, Introduction to Finite Elements in Engineering, Pearson Education, 2012

Experiment List (Minimum 12 exercises)

SL.NO	PART - A (Minimum 6 models)	COURSE OUTCOMES	HOURS
1	Creation of high end part models (minimum 2 models, Questions for examinations must not be taken from this portions)	CO1, CO2	6
2	Creating assembly models of Socket and spigot joint, Knuckle Joint, Rigid flange couplings, Bushed Pin flexible coupling, Plummer block, Single plate clutch and Cone friction clutch. Pipe joints, Screw jack, Tail stock etc. (minimum 4 models)	CO1, CO2, CO3	12
	PART – B (Minimum 6 problems)		
3	Structural analysis. (minimum 3 problems)	CO4, CO5	6
4	Thermal analysis. (minimum 2 problems)	CO4, CO5	3
5	Fluid flow analysis. (minimum 1 problem)	CO4, CO5	3

END SEMSTER EXAMINATION  
MODEL QUESTION PAPER

MEL332: COMPUTER AIDED DESIGN AND ANALYSIS LAB

Duration : 2.5 hours

Marks : 75

Note :

1. All dimensions in mm
2. Assume missing dimensions appropriately
3. A4 size answer booklet shall be supplied
4. Viva Voce shall be conducted for 10 marks

PART A (ASSEMBLY MODELLING) – 35 marks

1. Create an assembly model using the part details given below

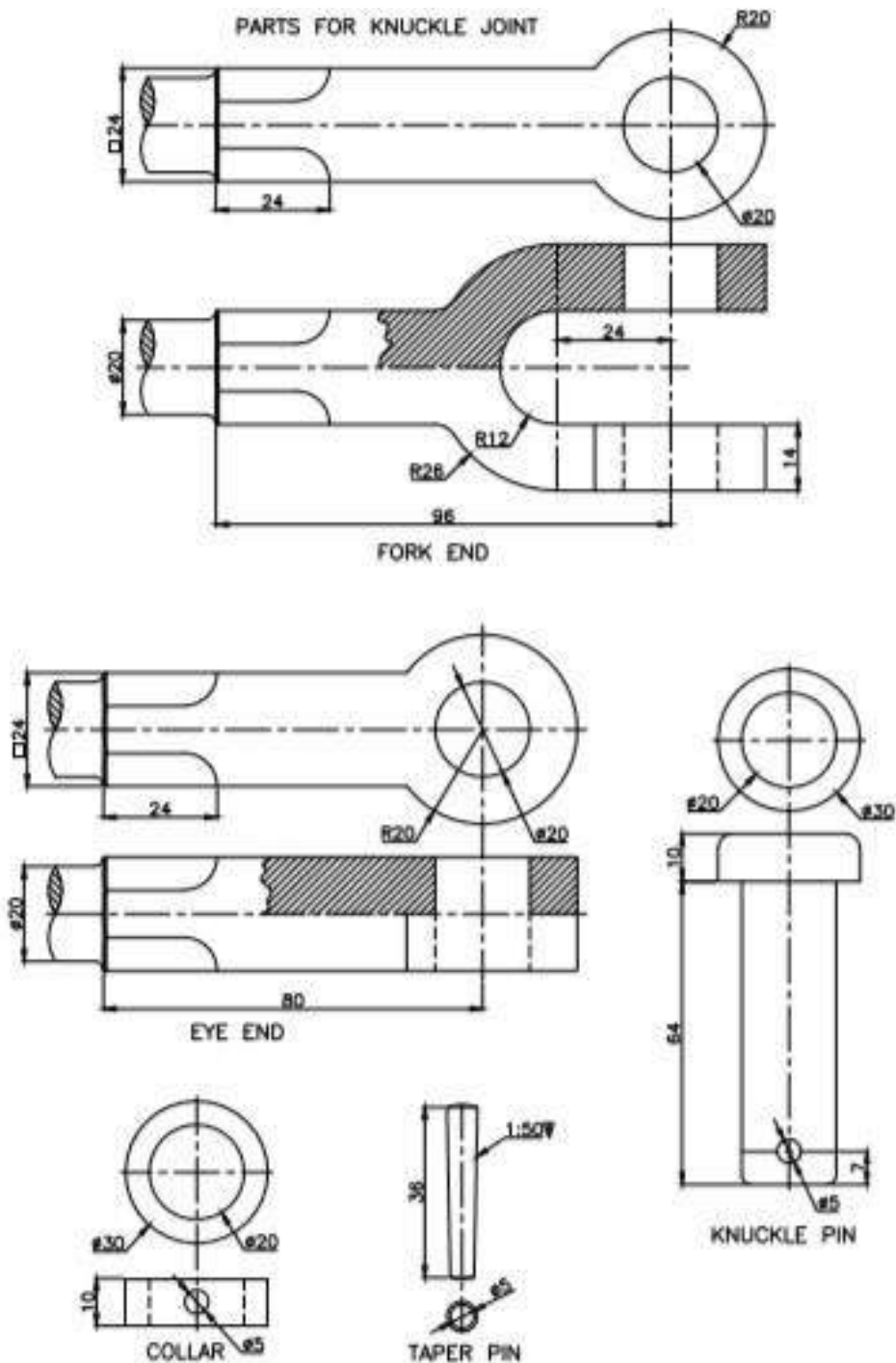

PART B (FINITE ELEMENT ANALYSIS) – 30 marks

2. Air flows over a long cylinder of 150mm diameter at a velocity of 3m/sec at a temperature of 105° F. Using this data and applying finite element technique find
  - a. Max velocity
  - b. Plot flow trajectories
  - c. Cut plot of velocity



COURSE CODE	COURSE NAME	CATEGORY	L	T	P	CREDITS
22MEL609	THERMAL ENGINEERING LAB II	ES	0	0	3	2

Preamble: The course is intended to enable the students to get exposed to equipment related to heat and mass transfer. This includes understanding the working of equipments related to various heat transfer processes viz conduction, convection, radiation and mass transfer. These equipments are heat exchangers, refrigeration and air conditioning systems, compressor/blower and their applications in real life problems. Also the thermo physical properties of materials which are integral to these equipments will also be evaluated. Apart from this, calibration of various instruments which are essential to these equipments will be done.

Prerequisite: Should have undergone a course on Heat and Mass Transfer

Course Outcomes: After the completion of the course the student will be able to

CO 1	Evaluate thermal properties of materials in conduction, convection and radiation
CO 2	Analyse the performance of heat exchangers
CO 3	Illustrate the operational performances of refrigeration and air conditioning systems
CO 4	Perform calibration of thermocouples and pressure gauges

Mapping of course outcomes with program outcomes

	PO 1	PO 2	PO 3	PO 4	PO 5	PO 6	PO 7	PO 8	PO 9	PO 10	PO 11	PO 12
CO 1	3		2	3			2		3	2		2
CO 2	3		2	3			2		3	2		2
CO 3	3		2	3			2		3	2		2
CO 4	3		2	3			2		3	2		2

Assessment Pattern

Mark distribution

Total Marks	CIE	ESE	ESE Duration
150	75	75	2.5 hours

### Continuous Internal Evaluation Pattern:

Attendance	:	15 marks
Continuous Assessment	:	30 marks
Internal Test (Immediately before the second series test)	:	30 marks

End Semester Examination Pattern: The following guidelines should be followed regarding award of marks

(a) Preliminary work	:	15 Marks
(b) Implementing the work/Conducting the experiment	:	10 Marks
(c) Performance, result and inference (usage of equipments and trouble shooting)	:	25 Marks
(d) Viva voce	:	20 marks
(e) Record	:	5 Marks

### General instructions:

Practical examination is to be conducted immediately after the second series test covering entire syllabus given below. Evaluation is a serious process that is to be conducted under the equal responsibility of both the internal and external examiners. The number of candidates evaluated per day should not exceed 20. Students shall be allowed for the University examination only on submitting the duly certified record. The external examiner shall endorse the record.

### Reference Books

1. Yunus A. Cengel, "Heat Transfer a Practical Approach", Tata McGraw-Hill Education, 4th Edition, 2012.
2. R. C. Sachdeva, "Fundamentals of Engineering, Heat and Mass Transfer", New Age publication, 3 rd Edition, 2012.
3. Holman J.P, "Heat transfer", Mc Graw-Hill, 10th. Ed., 2009
4. Frank P. Incropera and David P. Dewitt, Heat and Mass Transfer, John Wiley and sons, 2011
5. Kothandaraman, C.P., Fundamentals of Heat and Mass Transfer, New Age International, New Delhi, 2006

List of Exercises/Experiments: (Lab experiments may be given considering 12 sessions of 3 hours each. Minimum 12 experiments to be performed.)

1. Determination of LMTD and effectiveness of parallel flow, Counter flow and cross flow heat exchangers
2. Performance studies on a shell and tube heat exchanger
3. Development of heat transfer correlation for heat exchangers/condenser using modified Wilson Plot Method
4. Determination of heat transfer coefficients in free convection
5. Determination of heat transfer coefficients in forced convection
6. Determination of thermal conductivity of solids (composite wall/metal rod)
7. Determination of thermal conductivity of powder
8. Determination of thermal conductivity of liquids
9. Measurement of unsteady state conduction heat transfer
10. Determination of emissivity of a specimen
11. Determination of Stefan Boltzman constant
12. Measurement of solar radiation
13. Experimental study of dropwise and filmwise condensation
14. Experiments on boiling heat transfer
15. Study and performance test on refrigeration (Refrigeration Test rig)
16. Study and performance test on air conditioning equipment (Air Conditioning test rig)
17. Performance study on heat pipe
18. Calibration of Thermocouples
19. Calibration of Pressure gauge

---

SEMESTER VI

---

MINOR

---

COURSE CODE	COURSE NAME	CATEGORY	L	T	P	CREDITS
22MEMR609.1	MACHINE DESIGN	MR	3	1		4

Preamble: This course mainly covers elementary topics of strength of materials such as stresses, strains, stress concentration, etc. Failure theories to predict the failure of machine elements subjected to static and fatigue loading are also covered. Design of bolts, riveted joints, welded joints, springs and shafts are also incorporated in this syllabus.

Prerequisite: EST100 Engineering Mechanics

Course Outcomes: After the completion of the course the student will be able to:

CO 1	To calculate the different types of stresses in a structural member.
CO 2	To apply failure theories and predict the failure of components.
CO 3	To design bolts subjected to fatigue loads.
CO 4	To design riveted and welded joints.
CO 5	To design close coiled helical compression springs and shafts subjected to static and fatigue loads.

Mapping of course outcomes with program outcomes

	PO 1	PO 2	PO 3	PO 4	PO 5	PO 6	PO 7	PO 8	PO 9	PO 10	PO 11	PO 12
CO 1	3	3	2									
CO 2	3	3	2									
CO 3	3	3	2									
CO 4	3	3	2									
CO 5	3	3	2									

Assessment Pattern

Bloom's Category	Continuous Assessment Tests		End Semester Examination
	1	2	
Remember	10	10	10
Understand	20	20	20
Apply	20	20	70
Analyse			
Evaluate			
Create			

Mark distribution

Total Marks	CIE	ESE	ESE Duration
150	50	100	3 hours

### Continuous Internal Evaluation Pattern:

Attendance	: 10 marks
Continuous Assessment Test (2 numbers)	: 25 marks
Assignment/Quiz/Course project	: 15 marks

End Semester Examination Pattern: There will be two parts; Part A and Part B. Part A contain 10 questions with 2 questions from each module, having 3 marks for each question. Students should answer all questions. Part B contains 2 questions from each module of which student should answer any one. Each question can have maximum 2 sub-divisions and carry 14 marks.

### Course Level Assessment Questions

#### Course Outcome 1 (CO1):

1. Define stress concentration factor and factor of safety.
2. Calculate the principal stresses in a structural member subjected to loads in two directions.
3. Draw stress strain diagram and explain its significance in the design of machine elements.
4. Calculate the equivalent stress due to combined axial, bending and torsional loads.

#### Course Outcome 2 (CO2)

1. Explain the steps in the design process.
2. Distinguish between codes and standards.
3. Describe with neat sketches the different types of fits.
4. What are the different failure theories? What is the significance in design?

#### Course Outcome 3 (CO3)

1. Define endurance limit. What are the factors affecting it?
2. Explain Soderberg's and Goodman's criteria.
3. Derive an expression for the impact stress in terms of static stress.
4. What is meant by preloading or initial tension in a bolt?
5. Design a bolted joint subjected to eccentric loading.

#### Course Outcome 4 (CO4):

1. What are the advantages of riveted joint over welded joint?
2. Describe the different modes of failure of a riveted joint.
3. Find the various efficiencies of a riveted joint.

4. Describe the different AWS welding symbols.
5. Design a welded joint subjected to axial loading, twisting moment and bending moment.

Course Outcome 5 (CO5):

1. Design a close coiled helical compression spring subjected to axial loading.
2. Explain surge in spring.
3. What are the different types of end constructions for a close coiled helical compression spring? How do they affect the performance of the spring?
4. What is critical speed of a shaft?
5. Why hollow shafts are preferred in certain applications compared to solid shafts?

### MODEL QUESTION PAPER

#### VI SEMESTER BTECH DEGREE EXAMINATION

#### MET382 : MACHINE DESIGN

Maximum: 100 Marks

Duration:3 hours

#### PART A

Answer all questions, each question carries 3 marks

1. Define stress concentration and factor of safety.
2. Distinguish between normal stress and principal stress.
3. What are standards and codes?
4. Explain Haigh's and Rankine's theories of failures.
5. Why preloading of bolts is required?
6. Define endurance limit. What is its significance in design of machine elements?
7. Describe the different modes of failure of a riveted joint.
8. Explain with a neat sketch the AWS welding symbols
9. Derive an expression for the stress in a closed coiled helical compression spring.
10. What is meant by the critical speed of a shaft?

## PART B

Answer one full question from each module

### MODULE 1

11. a) An element in plane stress is subjected to stresses  $\sigma_{xx} = 85$  MPa,  $\sigma_{yy} = -30$  MPa and  $\tau_{xy} = -32$  MPa. Determine the principal stresses and the maximum shear stress (9 marks)
- b) Draw the shear stress, bending stress, axial stress and torsional shear stress in a shaft of circular cross-section. (5 marks)
12. a) Draw the stress-strain diagram for mild steel and show all the significant regions. (5 marks)
- b) Find the maximum stress in the cantilever beam shown below. The material is aluminium. The rod length  $L = 15$  cm. The permissible tensile and shear stresses are  $70$  N/mm<sup>2</sup> and  $50$  N/mm<sup>2</sup> respectively. (10 marks)

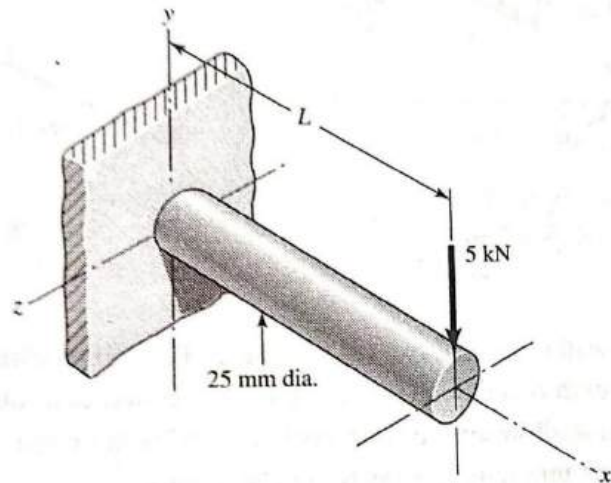

### MODULE 2

13. a) Explain allowances and tolerances. (5 marks)
- b) A mild steel shaft having yield stress  $\sigma_{yp} = 200$  MPa is subjected to the following stresses.  $\sigma_x = 120$  MPa,  $\sigma_y = -60$  MPa,  $\tau_{xy} = 36$  MPa. Find the factor of safety using
- Rankine's theory
  - Guest's theory (10 marks)
14. a) With neat sketches explain clearance fit, interference fit and transition fit. (6 marks)
- b) What are the steps in the design process. (6 marks)
- c) Explain preferred sizes. (2 marks)



### MODULE 3

15. a) A round prismatic steel bar ( $E = 210 \text{ GPa}$ ) of length  $2 \text{ m}$  and diameter  $15 \text{ mm}$  hangs vertically from a support at its upper end. A sliding collar of mass  $20 \text{ kg}$  drops from a height of  $150 \text{ mm}$  onto a flange fixed at the lower end of the bar without rebounding. Calculate the maximum elongation of the bar due to impact. Also, determine the maximum tensile stress in the bar and the corresponding impact factor  
(10 marks)
- b) Explain the Gerber criterion used in the design for fatigue loading. (4 marks)
16. a) With a neat sketch explain the nominal diameter, root diameter and pitch diameter and pitch of a screw thread. (3 marks)
- b) Find the diameter of the bolt for a bracket loaded as shown below. The allowable shear stress for bolt material is  $60 \text{ MPa}$ . (11 marks)

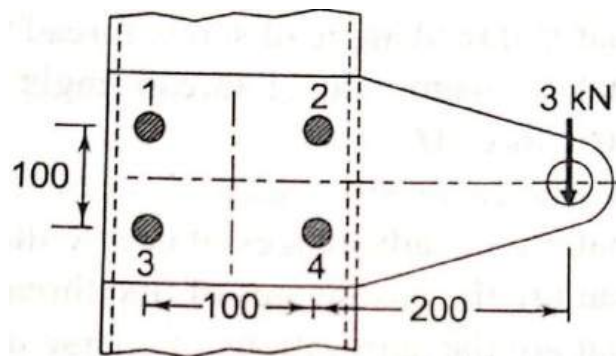

### MODULE 4

17. a) What are the advantages of welded joint over riveted joint? (9 marks)
- b) Two plates are joined together by means of a single transverse and double parallel fillet welds are shown in figure. The size of the fillet weld is  $5 \text{ mm}$  and allowable shear load per mm of weld is  $330 \text{ N}$ . Find the length of each parallel fillet weld. (10 marks)

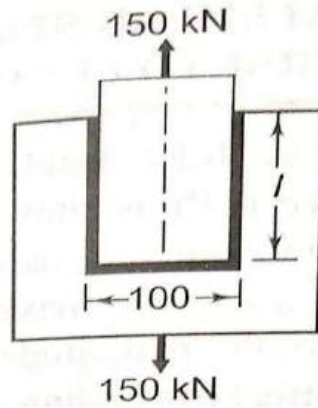

18. a) Draw a zig-zag-double riveted double covered (equal) butt joint and mark all the details. (4 marks)

b) Two flat plates of width  $w = 200$  mm, subjected to a tensile force  $P = 250$  kN are connected together by means of a double-strap butt joint as shown below. The rivets and the plates are made of the same steel and the permissible stresses in tension, compression and shear are  $70$ ,  $100$  and  $60$  N/mm<sup>2</sup> respectively. Calculate the i) diameter of the rivets, ii) thickness of the plates and iv) the efficiency of the joint.

(10 marks)

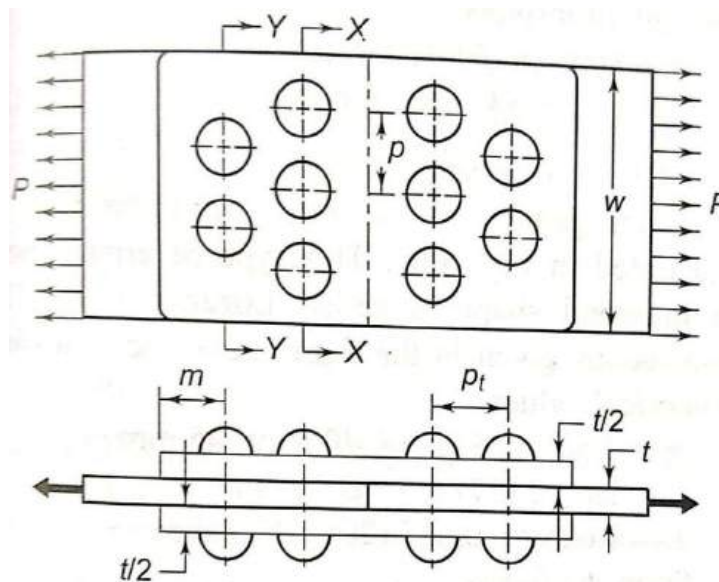

### MODULE 5

19. a) Explain surge in springs. (4 marks)

b) It is required to design a helical compression spring subjected to a maximum force of  $1250$  N. The deflection of the spring corresponding to the maximum force should

be approximately 30 mm. The spring index can be taken as 6. The ultimate tensile strength and modulus of rigidity of the spring material are 1090 and 81370 N/mm<sup>2</sup> respectively. The permissible shear stress for the spring wire should be taken as 50% of the ultimate tensile strength. Design the spring and calculate: i) wire diameter, ii) mean coil diameter, iii) number of active coils, iv) total number of coils, v) free length of the spring and pitch of the coil. (10 marks)

20. a) A line shaft supporting two pulleys A and B is shown in figure. Power is supplied to the shaft by means of a vertical belt on the pulley A, which is then transmitted to the pulley B carrying a horizontal belt. The ratio of belt tensions on tight and loose sides is 3:1. The limiting value of tension in the belt is 2.7 kN. The permissible shear stress is 86 N/mm<sup>2</sup>. Pulleys are keyed to the shaft. Determine the diameter of the shaft according to the ASME code, if  $K_b = 1.5$  and  $K_t = 1.0$ . (10 marks)

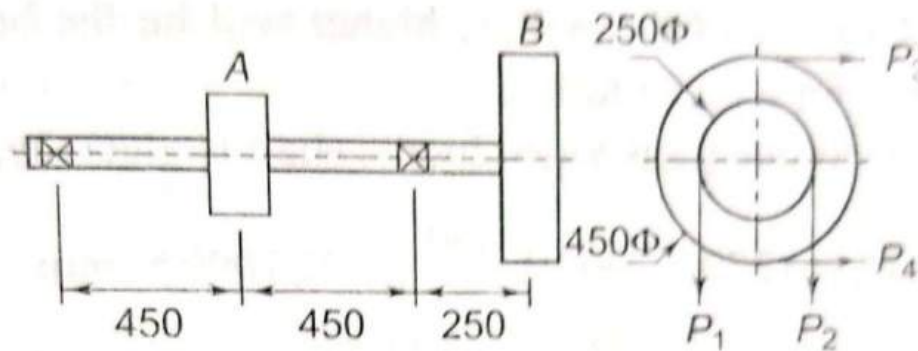

- b) Two shafts ; one solid and the other hollow, have the same weight and transmit the same torque. Calculate the ratio of the maximum shear stress induced in the solid shaft to that in the hollow shaft. The inner diameter of the hollow shaft is 50% of the outer diameter. (5 marks)

# Syllabus

## Module 1

Tension, compression, shear: Introduction, Internal force, stress, strain, elasticity, stress-strain diagram, working stress, stress concentration, factor of safety, bending and torsional stresses, eccentric loading, stresses due to combined axial, bending and torsional loads, principal stresses

## Module 2

Machine design, steps in the design process, standards and codes, preferred sizes, tolerances, allowances, fits, selection of materials

Theories of elastic failures- Guest's theory, Rankine's theory, St. Venant's theory, Haigh's theory, and Von Mises and Hencky Theory.

## Module 3

Shock and impact loads, fatigue loading, endurance limit stress, factors affecting endurance limit, design for fatigue loading, Soderberg and Goodman criteria.

Threaded joints, types of threads, stresses in screw threads, bolted joints, initial tension, design of bolts for static and fatigue loading, power screws

## Module 4

Design of riveted joints- material for rivets, modes of failure, efficiency of joint, design of boiler and tank joints, structural joints

Design of welded joints- AWS welding symbols, stresses in fillet and butt welds, butt joint in tension, fillet weld in tension, fillet joint under torsion, fillet weld under bending, eccentrically loaded welds.

## Module 5

Springs- classification, spring materials, stresses and deflection of helical springs, axial loading, static and fatigue loading, surging, critical frequency, concentric springs, end construction.

Shafting- material, design considerations, causes of failure in shafts, design based on strength, rigidity, critical speed, design for static and fatigue loads, repeated loading, reversed bending

## Text Books

1. Bhandari V B, Design of Machine Elements, Tata McGraw-Hill Education, 2010.
2. James M Gere, Mechanics of Materials, Thomson, 2007

Reference Books

1. S P Timoshenko and D H Young, Elements of Strength of Materials, East West Pvt Ltd.,2011
3. Robert L Norton, Design of Machinery, Tata Mc Graw-Hill, 2005
4. P C Sharma and D K Aggarwal, Machine Design, S K Kataria & Sons, 2007.

Course Contents and Lecture Schedule

No	Topic	No. of Lectures (Hrs.)
1		
1.1	Tension, compression, shear-Introduction, internal force, stress, strain, elasticity	3
1.2	Stress-strain diagram, working stress, stress concentration, factor of safety	2
1.3	Bending and torsional stresses, eccentric loading, stresses due to combined axial, bending and torsional loads, principal stresses	3
2		
2.1	Machine design, steps in the design process, standards and codes	3
2.2	Preferred sizes, tolerances, allowances, fits, selection of materials	2
2.3	Theories of elastic failures- Guest's theory, Rankine's theory, St. Venant's theory, Haigh's theory, and Von Mises and Hencky Theory.	3
3		
3.1	Shock and impact loads, fatigue loading, endurance limit stress, factors affecting endurance limit	2
3.2	Design for fatigue loading, Soderberg and Goodman's criteria.	2
3.3	Threaded joints, types of threads, stresses in screw threads, bolted joints, initial tension	2
3.4	Design of bolts for static and fatigue loading, eccentric loading, power screws	2
4		
4.1	Design of riveted joints- material for rivets, modes of failure, rivet and butt joints, efficiency of joint, design of structural joints	3
4.2	Design of welded joints- AWS welding symbols, stresses in fillet and butt welds, Butt joint in tension, fillet weld in tension,	3
4.3	Fillet joint under torsion, fillet wed under bending, eccentrically loaded welds.	3
5		
5.1	Springs- classification, spring materials, stresses and deflection of	3

	helical springs, axial loading	
5.2	Static and fatigue loading, surging, critical frequency, concentric springs, end construction	3
5.3	Shafting- material, design considerations, causes of failure in shafts, hollow and solid shafts, design based on strength, rigidity,	3
5.4	Critical speed, design for static and fatigue loads, repeated loading, reversed bending	3

COURSE CODE	COURSE NAME	CATEGORY	L	T	P	CREDITS
22MEMR609.2	HEAT TRANSFER	MR	3	1		4

Preamble:

The objectives of the course are:

- To introduce the heat transfer by conduction, convection and radiation modes.
- To provide useful information for solving the heat transfer problems across the plane and cylindrical sections
- To give enough ideas to solve the heat transfer problems involving convection heat transfer
- To determine the performance of heat exchangers
- Present and solve the various types of radiation heat transfer problems

Prerequisite: MET203 Mechanics of fluid

Course Outcomes: After the completion of the course the student will be able to

CO 1	To understand the basics of heat transfer.
CO 2	To estimate heat transfer through plane wall, cylindrical surface and fins for various conditions.
CO 3	To solve problems involving heat convection.
CO 4	To solve the problems of heat exchangers and to determine its performance.
CO 5	To estimate radiation heat transfer between two bodies.

Mapping of course outcomes with program outcomes

	PO 1	PO 2	PO 3	PO 4	PO 5	PO 6	PO 7	PO 8	PO 9	PO 10	PO 11	PO 12
CO 1	3											1
CO 2	2	3	2								1	1
CO 3	2	2	2								1	1
CO 4	2	3	2								1	1

Assessment Pattern

Bloom's Category	Continuous Assessment			End Semester Examination
	Assignment (%)	Test 1 (%)	Test 2 (%)	
Remember	30	20	20	10
Understand	30	40	40	20
Apply	40	40	40	70
Analyse				
Evaluate				
Create				

## Mark distribution

Total Marks	CIE	ESE	ESE Duration
150	50	100	3 hours

### Continuous Internal Evaluation Pattern:

Attendance	: 10 marks
Continuous Assessment Test (2 numbers)	: 25 marks
Assignment/Quiz/Course project	: 15 marks

End Semester Examination Pattern: There will be two parts; Part A and Part B. Part A contain 10 questions with 2 questions from each module, having 3 marks for each question. Students should answer all questions. Part B contains 2 questions from each module of which student should answer any one. Each question can have maximum 2 sub-divisions and carry 14 marks.

### Course Level Assessment Questions

#### Course Outcome 1 (CO1):

1. Explain Fourier's law of heat conduction?
2. Derive the equation of general heat conduction equation in Cartesian coordinates?

#### Course Outcome 2 (CO2)

1. The interior temperature of a refrigerator is maintained at  $7^{\circ}\text{C}$ . The walls are constructed with two mild steel sheets 3 mm thick with 5 cm of glass wool insulation between them. The heat transfer coefficients on inner and outer surface of refrigerator are  $10 \text{ W/m}^2\text{C}$  and  $12.5 \text{ W/m}^2\text{C}$  respectively. Find the rate of heat leaked the refrigerator in watts when it is kept in a kitchen room. Also find inter wall temperatures. The temperature in kitchen room is  $28^{\circ}\text{C}$ . Take  $K$  (mild steel) =  $40 \text{ W/m}\cdot^{\circ}\text{C}$   $K$  (glass wool) =  $0.04 \text{ W/m}\cdot^{\circ}\text{C}$ . Demonstrate the operation of stack and stack pointer through push and pop Instructions.
2. Derive an equation for one dimensional heat conduction through a plane wall and represent it in a form of electrical analogy?

#### Course Outcome 3(CO3):

1. Explain Newton's law of convective heat transfer?
2. Explain hydrodynamic boundary layer with the help of a neat diagram.
3. Define Reynolds Number, Prandtl Number and Nusselt Number.

#### Course Outcome 4 (CO4):

1. What is LMTD? What is the need of determine the LMTD?
2. In a double pipe heat exchanger hot water flows at a rate of 14 kg/s and gets cooled from 370K to 340K. At the same time 14 kg/s of cooling water at 303K enters the heat exchanger. The flow conditions are such that overall heat transfer coefficient remains constant at 2270



W/m<sup>2</sup> K. Determine the effectiveness and the heat transfer area required, assuming two streams are in parallel flow. Assume the specific heat for the both the streams = 4.2 kJ/kg K.

Course Outcome 5 (CO5):

1. Explains Stephan Boltzmann law of heat radiation?
2. Explain Wien's displacement law?

## MODEL QUESTION PAPER

### SIXTH SEMESTER MECHANICAL ENGINEERING

#### Heat Transfer-MET384

Maximum: 100 Marks

Duration: 3 hours

#### PART A

Answer all questions. Each question carries 3 marks

1. Explain Fourier's law of heat conduction?
2. What are the factors affecting thermal conductivity of solids, liquids and gases?
3. Write the equation for one dimensional heat conduction through a plane wall and represent it in a form of electrical analogy?
4. What is critical thickness of insulation and what is its importance?
5. Define Reynolds Number, Prandtl Number and Nusselt Number?
6. What is the difference between free and forced convection?
7. What is meant by NTU in heat exchangers? When it is used?
8. What is effectiveness of a heat exchanger?
9. Explains Stephan Boltzmann law of heat radiation?
10. Explain Wien's displacement law?

(10 X 3 = 30 Marks)

#### PART B

Answer one full question from each module

#### MODULE 1

11. a) Derive general conduction equation in Cartesian coordinate? (10 marks)
- b) reduce the equation for steady one dimensional conduction heat transfer for homogeneous isotropic material without heat generation. (4marks)
12. a) Explain three different modes of heat transfer? (10 marks)
- b) Write down the general conduction equation in cylindrical coordinate and explain the terms? (4 marks)

## MODULE II

13. a) The interior temperature of a refrigerator is maintained at  $7^{\circ}\text{C}$ . The walls are constructed with two mild steel sheets 3 mm thick with 5 cm of glass wool insulation between them. The heat transfer coefficients on inner and outer surface of refrigerator are  $10 \text{ W/m}^2\text{C}$  and  $12.5 \text{ W/m}^2 \text{ }^{\circ}\text{C}$  respectively. Find the rate of heat leaked the refrigerator in watts when it is kept in a kitchen room. Also find inter wall temperatures. The temperature in kitchen room is  $28^{\circ}\text{C}$ . Take  $K$  (mild steel) =  $40 \text{ W/m-}^{\circ}\text{C}$   $K$  (glass wool) =  $0.04 \text{ W/m-}^{\circ}\text{C}$ . (10 marks)
- b) Write an expression for one dimensional heat transfer along radial direction, through a hollow cylindrical surface of radius  $R_1$  and  $R_2$ , thermal conductivity  $K$  and length  $L$ . express it as an analogy of electric flow (4 marks)
- 14 a) Derive an expression for heat flow through “rectangular fin” of infinite length ? (12 marks)
- b) What is the propose of a fins? (2 marks)

## MODULE III

- 15 a) Air at  $20^{\circ}\text{C}$  at atmospheric pressure flows over a flat plate at a velocity of 3 m/s. If the plate is 1 m wide and at  $80^{\circ}\text{C}$ , calculate the following at  $x = 300 \text{ mm}$ . Determine Hydrodynamic boundary layer thickness, Thermal boundary layer thickness, Local friction coefficient, Average heat transfer coefficient, Heat transfer rate (10 marks)
- b) What is the difference between laminar and turbulent flow? (4 marks)
- 16 a) Air at pressure of 1 atm and temperature  $60^{\circ}\text{C}$  flows over a flat plate which maintains a surface temperature of  $100^{\circ}\text{C}$ . The plate has a length of 0.2m (in the flow direction) and width of 0.1m. The Reynolds number based on the plate length is 40000. What is the rate of heat transfer from plate to air? If the free stream velocity of air is doubled and the pressure is increased to 2.5 atm, what is the rate of heat transfer? (12 marks)
- b) What is the importance of Reynolds number? (2 marks)

## MODULE IV

17. a) Derive an expression for LMTD of “parallel flow” heat exchanger (10 marks)
- b) What is fouling and scaling of heat exchangers? How to accommodate this factor in calculation (4 marks)

18. a) A chemical having specific heat of 3.3 KJ/kg K, flowing at the rate of 20000 kg/h enters a parallel flow heat exchanger at 120° C. The flow rate of cooling water is 50000 kg/h with an inlet temperature of 20°C. The heat transfer area is 10 m<sup>2</sup> and the overall heat transfer coefficient is 1050 W/m<sup>2</sup> K. Take specific heat of water as 4.186 KJ/kg K Find: (i) The effectiveness of the heat exchanger. (ii) The outlet temperature of water and chemical.

(12 marks)

b) Explain matrix type of heat exchangers?

(2 marks)

#### MODULE V

19 a) Calculate the heat exchange by radiation between the surfaces of two long cylinders having radii 120 mm and 60 mm respectively. The axes of the cylinders are parallel to each other. The inner cylinder is maintained at a temperature of 130°C and emissivity of 0.6. Outer cylinder is maintained at a temperature of 30°C and emissivity of 0.5.

(10 marks)

b) Explains Stephan Boltzmann law of heat radiation?

(4 marks)

20. a) Calculate the radiation exchange per unit area between two parallel plates of temperature 4000C and 250C. Emissivity of hot and cold plates are 0.9 and 0.7 respectively. Find the percentage reduction in heat transfer, if a radiation shield of emissivity 0.25 is placed in between the plates

(7 marks)

b) Explain Wien's displacement law?

(7 marks)

#### Syllabus

##### Module 1- INTRODUCTION TO HEAT TRANSFER

Modes of Heat Transfer: Introduction to Conduction, Convection, radiation. Conduction: Fourier law of heat conduction-Thermal conductivity of solids, liquids and gases-Factors affecting thermal conductivity- Most general heat conduction equation in Cartesian and cylindrical coordinates.

##### Module 2 CONDUCTION HEAT TRANSFER

One dimensional steady state conduction with and without heat generation conduction through plane walls, cylinders. Critical thickness of insulation – Heat transfer through composite wall- extended surface heat transfer – fin performance – effect of variable thermal conductivity.

##### Module 3 CONVECTION HEAT TRANSFER

Convection heat transfer: Newton's law of cooling- Free and forced convection. Laminar and Turbulent flow, Reynolds Number, Critical Reynolds Number, Prandtl Number, Nusselt Number, Grashoff Number and Rayleigh's Number. Elementary ideas of hydrodynamics and thermal boundary layers-Thickness of Boundary layer-Displacement, Momentum and Energy thickness (description only).

##### Module 4 HEAT EXCHANGERS

Heat exchangers: Classification – log mean temperature difference – overall heat transfer coefficient – fouling and scaling of heat exchangers – LMTD and NTU method of performance evaluation of heat exchangers.

## Module 5 RADIATION HEAT TRANSFER

Radiation: Fundamentals of radiation – radiation spectrum – thermal radiation – concept of black body and grey body – monochromatic and total emissive power – absorptivity, reflectivity and transmissivity - laws of radiation – radiation between two surfaces – geometrical factors for simple configuration – radiation shields – electrical network method of solving problems.

### Text Books

1. Sachdeva R. C., Fundamentals of Engineering Heat and Mass Transfer, New Age Science Limited
2. R. K. Rajput, Heat and mass transfer, S. Chand & Co.
3. Nag P. K., Heat and Mass Transfer, McGraw Hill.
4. Kothandaraman, C.P., Fundamentals of Heat and Mass Transfer, New Age International, New Delhi.

### Data Book

Heat and Mass Transfer data book: C.P. Kothandaraman, S. Subramanyan, New age International publishers.

### Reference Books

1. Holman J.P, “Heat transfer”, Mc Graw-Hill, 10th. Ed.
2. Yunus A Cengel, “Heat and Mass Transfer: Fundamentals and Applications” McGraw-Hill Higher Education.
3. Frank P. Incropera and David P. Dewitt, Heat and Mass Transfer, John Wiley and sons.

## COURSE PLAN

MODULE	TOPICS	HOURS ALLOTTED
1	Modes of Heat Transfer: Introduction to Conduction, Convection, radiation. Conduction: Fourier law of heat conduction-Thermal conductivity of solids, liquids and gases-Factors affecting thermal conductivity	4-0-0
	General heat conduction equation in Cartesian coordinates. General heat conduction equation in Cylindrical coordinates	3-1-0
2	One dimensional steady state conduction with and without heat generation conduction through plane walls, cylinders. Critical thickness of insulation – Heat transfer through composite wall- extended surface heat transfer – fin performance – effect of variable thermal conductivity.	8-2-0
	Convection heat transfer: Newton’s law of cooling- Free and forced convection. Laminar and Turbulent flow, Reynolds Number, Critical	

3	Reynolds Number, Prandtl Number, Nusselt Number, Grashoff Number and Rayleigh's Number. Elementary ideas of hydrodynamics and thermal boundary layers-Thickness of Boundary layer-Displacement, Momentum and Energy thickness	7-2-0
4	Heat exchangers: Classification – log mean temperature difference – overall heat transfer coefficient – fouling and scaling of heat exchangers – LMTD and NTU method of performance evaluation of heat exchangers	8-2-0
5	Radiation: Fundamentals of radiation – radiation spectrum – thermal radiation – concept of black body and grey body – monochromatic and total emissive power – absorptivity, reflectivity and transmissivity - laws of radiation – radiation between two surfaces – geometrical factors for simple configuration – radiation shields – electrical network method of solving problems.	7-2-0

COURSE CODE	COURSE NAME	CATEGORY	L	T	P	CREDITS
22MEMR609.3	INDUSTRIAL ENGINEERING	MR	3	1		4

Preamble: This course helps an engineering student to understand the functions and techniques of Industrial Engineering. It addresses economic aspects of the business decision and the concepts of human factors in design. The course involves productivity improvement methods, Work study, Method study and Time study. Industrial Engineering Tools and Techniques for Plant management including Plant layout and Material handling are also covered in this course. The students also will able understand Production Planning and Control process, and procedures. The other focus areas of Industrial Engineering, Quality practices, Project Management and Replacement technique are also part of this course.

Prerequisite: NIL

Course Outcomes: After the completion of the course the student will be able to

CO 1	Understand the functions of Industrial Engineering, Economic aspects of business and Human factors in design
CO 2	Apply Principles of Work study, Method study and Work measurement techniques.
CO 3	Develop layout for a manufacturing/service system and apply plant management and Material handling techniques.
CO 4	Evaluate Production Planning and Control techniques and Inventory control
CO 5	Analyse Quality practices, and Apply Project Management and Replacement techniques.

Mapping of course outcomes with program outcomes

	PO 1	PO 2	PO 3	PO 4	PO 5	PO 6	PO 7	PO 8	PO 9	PO 10	PO 11	PO 12
CO 1			2			3	3				3	
CO 2		3	3			3						
CO 3		3	3		3							
CO 4		3	3	3	3						3	
CO 5		3	3	3		3	3				3	

## Assessment Pattern

Bloom's Category	Continuous Assessment Tests		End Semester Examination
	1	2	
Remember	10	10	10
Understand	20	20	20
Apply	20	20	70
Analyse			
Evaluate			
Create			

## Mark distribution

Total Marks	CIE	ESE	ESE Duration
150	50	100	3 hours

## Continuous Internal Evaluation Pattern:

Attendance : 10 marks

Continuous Assessment Test (2 numbers) : 25 marks

Assignment/Quiz/Course project : 15 marks

End Semester Examination Pattern: There will be two parts; Part A and Part B. Part A contain 10 questions with 2 questions from each module, having 3 marks for each question. Students should answer all questions. Part B contains 2 questions from each module of which student should answer any one. Each question can have maximum 2 sub-divisions and carry 14 marks.

## Course Level Assessment Questions

### Course Outcome 1 (CO1):

1. State functions of an Industrial Engineer which will lead to improvement in productivity?.
2. How the productivity of s system can be improved? List factors affecting productivity that can be controlled.

3. Asian industries specialize in the manufacture of small capacity motors. The cost structure of the motor is as under

Material	Rs 50/-
Labour	Rs 80/-
Variable overhead	75% of labour cost
Fixed cost of the company amount 2,40,000 Rs/annum	
The sales price of the motor is Rs 230/- each	

Determine the number of motors to be manufactured to break even

How many motors are to be sold to make a profit of Rs 1 Lakh

If the sale price is reduced by Rs. 15/- how many motors are to sold to break even

Course Outcome 2 (CO2)

1. What is the concept of work content? What are reasons for excess of work content?
2. Differentiate between Two hand process chart and Multiple Activity chart.
3. The following data refers to the study conducted for an operation. The table shows the actual time for elements in minutes.

Cycle elements	1	2	3	4	5
1	2.5	2.6	2.4	2.5	2.5
2	6.0	6.2	6.1	5.9	6.0
3	2.3	2.1	2.4	2.2	2.3
4	2.4	2.5	2.6	2.8	2.5

i) Element 3 is machine elements

ii) Take performance rating as 110

Take following personal allowance of 30 minutes in shift of 8 hours, fatigue allowance 15%, contingency allowance 2%. Estimate the standard time for the operation and production per 8 hour shift.



Course Outcome 3(CO3):

1. List the different types of layout. Differentiate between Product and process layout based any five parameters.
2. Consider the following assembly network relationships of a product. The number of shifts per day is two and the number of working hours per shift is 8. The company aims to produce 80 units of the product per day. Group the activities into work stations using Ranking Positional Weight method and compute balancing efficiency.

Operation Number	Immediate predecessor	Duration (Min)
1	-	7
2	1	2
3	1	2
4	1	5
5	2,3	8
6	3,4	3
7	5	4
8	5,6	7
9	4,6	9
10	7,8,9	8

3. The initial cost of an equipment is Rs 21000/- expected salvage value Rs 1000 and expected useful life of 10 years. Calculate the depreciation and book value after 1 year and 9 years using sinking fund method and straight line method. Take interest rate as 6%

Course Outcome 4 (CO4):

1. Explain the steps of Production planning Process,
2. Describe the importance Product Life cycle in Product development and Management
3. A manufacturer has to supply his customer a 2400 units of his products per year. Shortages are not permitted. Inventory carrying cost amounts to Rs. 0.8/- per unit per annum. The setup cost per run is Rs 60/- . Find
  - i. EOQ
  - ii. Optimum number of order per annum

- iii. Average annual inventory cost(min)
- iv. Optimum period of supply per order

Course Outcome 5 (CO5):

1. Explain the Procedure of X and R chart .
2. The mortality rate are given in the table below for certain type of electric bulb. There are 2000 bulb in use and it costs Rs 12/- to replace an individual bulb that has burnt. If all the bulbs are replaced simultaneously, it would cost Rs. 4/- per bulb. It is proposed to replace all the bulbs in fixed intervals, whether or not they have burnt out and to continue replacing burnt bulbs out bulbs if they fail. At what intervals should all the bulbs be replaced?

Week	1	2	3	4	5	6
Probability of failure	0.05	0.2	0.25	0.3	0.15	0.05

### Model Question paper

APJ ABDUL KALAM TECHNOLOGICAL UNIVERSITY  
SIXTH SEMESTER B.TECH DEGREE EXAMINATION

Course Code : MET386

Course Name : INDUSTRIAL ENGINEERING

Max. Marks : 100

Duration : 3 Hours

### Part A

(ANSWER ALL QUESTIONS, EACH QUESTION CARRIES 3 MARKS)

1. What are the factors influencing productivity?
2. Explain the role ergonomics plays in environmental man-machine interface
3. What is micro motion study? What are the steps involved?
4. Explain flow diagram with example
5. Explain REL Chart
6. Explain the criteria for selecting Material handling equipment
7. How order promising is done during Production planning
8. Briefly explain any three selective inventory control techniques

9. Explain the significance of Bathtub curve
10. Briefly explain the stages of TQM implementation

**Part B**

(ANSWER ONE FULL QUESTION FROM EACH MODULE)

**Module 1**

11. a) Explain the factors affecting make or buy decisions. (7marks)  
 b) ABC company plans to sell an article at local market. The articles are purchased at Rs 5 on the condition that all unsold items shall be returned. The rent for the space Rs 2000. The article will be sold at Rs 9 . Determine the number of articles which must be sold to i) to break even ii) to earn Rs 400 profit iii)if the company sells 750 articles . Calculate the margin of Safety (7 marks)
  
12. a) Explain the principles in the application of Anthropometric data. How it can be used in work place design? (8 marks)  
 b) Explain the functions of Industrial Engineering (6 Marks)

**Module 2**

13. a) Explain the use recording techniques in method study. Differentiate between Operations Process chart and Flow process chart. (7 Marks)  
 b) The observed time and the performance rating for five elements are given. Compute the standard time assuming rest and personal allowance as 15% and contingency as 2% of basic time.

Element	1	2	3	4	5
Observed	0.2	0.08	0.50	0.12	0.10
Performance rating	85	80	90	85	80

(7 Marks)

- 14 a) Explain the different techniques used for work measurement. (7 Marks)

b) The following data refers to the study conducted for an operation. The table shows the actual time for elements in minutes.

Cycle elements	1	2	3	4	5
1	2.5	2.6	2.4	2.5	2.5
2	6.0	6.2	6.1	5.9	6.0
3	2.3	2.1	2.4	2.2	2.3
4	2.4	2.5	2.6	2.8	2.5

i) Element 3 is machine elements

ii) Take performance rating as 110

Take following personal allowance of 30 minutes in shift of 8 hours, fatigue allowance 15%, contingency allowance 2%. Estimate the standard time for the operation and production per 8 hour shift. (7 Marks)

### Module 3

15. a) Explain Systematic Layout planning with the help of block diagram. (6 Marks)

b) Consider the following assembly network relationship of a product. The number of shifts per day is two and the number of working hours per shift is 12. The company aims to produce 100 units of the product per day. Group the activities into work stations using Rank Positional Weight Method and compute balancing efficiency.

Operation number	Immediate preceding Tasks	Duration (Min)
1	-	7
2	1	2
3	1	2
4	1	5
5	2,3	8
6	3,4	3

7	5	4
8	5,6	7
9	4,6	9
10	7,8,9	8

(8 Marks)

16 a) The initial cost of an equipment is Rs 21000/- expected salvage value Rs 1000 and expected useful life of 10 years. Calculate the depreciation and book value after 1 year and 9 years using sinking fund method and straight line method. Take interest rate as 6%. (6 Marks)

b) The price of an office equipment is Rs 2.5 lakhs the salvage value at the end of 10 years is Rs 25,000/ Calculate the amortised value after 5 years by using i) sinking fund method ii) declining balance method. (8 Marks)

#### Module 4

17 a) What are the different types of Production system, explain (7 Marks)

b) Consider the following 3 machine and 5 jobs flow shop problem. Check whether Johnson's can be extended to this problem. What is the optimal schedule for this problem and corresponding makespan? Draw the Gantt chart.

Job	Machine 1	Machine 2	Machine 3
1	11	10	12
2	13	8	20
3	15	6	15
4	12	7	19
5	20	9	7

(7 Marks)

18 a) Explain the Product Life cycle and its importance in Product management. (7 Marks)

b) ABC industry needs 15,000 units/year of a bought out component which will be used in its main product. The ordering cost is Rs. 125 per order and holding cost per unit per year is 20% of the purchase price per unit which is Rs. 75.

- i. Find economic order quantity
- ii. Number of order per year
- iii. Time between successive orders

The activities involved in ABC manufacturing company are listed below with their time estimates. Draw the network for the given activities and carry out critical path calculations.

(7 Marks)

### Module 5

19 a) Differentiate between PERT and CPM, Specify the difference in application (6 Marks)

b) Consider the following data of the project

Activity	Predecessor	Duration (Weeks)		
		<u>a</u>	<u>m</u>	<u>b</u>
A	–	3	5	8
B	–	6	7	9
C	A	4	5	9
D	B	3	5	8
E	A	4	6	9
F	C,D	5	8	11
G	C,D,E	3	6	9
H	F	1	2	9

- i. Construct the project network
- ii. Find expected duration and variance of each activity
- iii. What is the probability of completing the project in 30 weeks?

(8 Marks)

20 a) What is Process Capability? Explain the significance Process capability Index

(7 Marks)

b)The cost of a machine is Rs. 60,000/-. The salvage value and the running costs of a machine are shown in the table. Depreciation is cumulative. Find the most economical replacement age of the machine. (7 marks)

Year	1	2	3	4	5	6
Running cost in Rs.	12050	14100	16375	18875	20500	24550
Resale value in Rs	40000	30000	25000	15000	10500	7000

## Syllabus

### Module 1

Introduction to Industrial Engineering - Evolution of modern Concepts in Industrial Engineering - Functions of Industrial Engineering.

Productivity- productivity measures- dynamics of productivity change- Techniques for improving productivity.

Production costs concepts – Manufacturing Vs Purchase- problems- Economic aspects- C-V-P analysis – simple problems..

Ergonomics Man-Machine systems-Anthropometry Work place design and ergonomics - Value Engineering.

### Module 2

Work study-procedure-concept of work content- techniques to reduce work content.

Method Study-steps-recording techniques-operation process chart-flow process chart-two hand process chart-multiple activity chart. Diagrams- Flow diagrams-String diagrams. Micro-motion study-SIMO chart- critical examination. Principle of motion economy.

Work measurement- techniques of work measurement - Time Study- - Steps in time study-calculation of standard time (problems)- allowances.

### Module 3

Plant location, plant layout and material handling- Type of layouts and characteristics –Tools and techniques for plant layout- travel chart – REL chart- Computer algorithms for layout design CRAFT-ALDEP (methods only)- Systematic layout planning -Line balancing–RPW (problem).

Principles of material handling-selection and type of material handling equipment- Unit load concept- Automated Material Handling Systems- AGVs.

Depreciation -Method of providing for depreciation- straight line method- Declining balance method- Sinking fund methods (Problems)

### Module 4

Production Planning and control -Types of Production systems.

Demand forecasting- Forecasting methods, Aggregate planning- methods- Master Production Schedule-techniques-order promising- Material Requirement Planning-bill of material-

product structure diagram- MRP record processing- Shop floor control - Scheduling flow shop and job shop scheduling methods, Johnson's algorithm-dispatching rules - Gantt charts. Introduction and need for a new product-product life cycle.

Inventory Control, Inventory models – Basic model -price discounts -problems – determination of safety stock - Selective inventory control techniques

#### Module 5

Quality control - Statistical quality control –causes of variation in quality- control charts for X and R (problems). Process Capability- process capability index- Reliability-causes of failures- Bath tub curve.-System reliability. Introduction to concepts of, TQM, ISO, Six Sigma and Quality circles.

Project management- Critical Path Method, PERT, crashing of networks

Determination of economic life -Replacement policy-- Methods of replacement analysis.

#### Text Books

1. Martand Telsang, Industrial Engineering & Production Management, S. Chand, Third revised edition 2018.
2. B. Kumar, Industrial Engineering Khanna Publishers, Tenth Edition 2015
3. Thomas E Vollmann , William L Berry , D Clay Whybark, F Robert Jacobs, Manufacturing Planning and Control for Supply Chain Management, McGraw Hill Education (India) Private Limited, Fifth Edition 2017
4. M Mahajan, Industrial Engineering & Production Management, Dhanpat Rai, 2015
5. O. P. Khanna, Industrial Engineering and Management, Dhanpat Rai, 2018

#### Reference Books

1. E. S. Buffa, Modern Production management, John Wiley, 1983
2. Grant and Ieven Worth, Statistical Quality Control, McGraw Hill, 2000
3. Ralph M Barnes, Motion and Time Study, Wiley, 1980
4. Richard L. Francis, F. McGinnis Jr., John A. White, Facility Layout and Location: An Analytical Approach, 2nd Edition, 1991



## Course Contents and Lecture Schedule

No	Topic	No. of Lectures
1	<p>Introduction to Industrial Engineering - Evolution of modern Concepts in Industrial Engineering - Functions of Industrial Engineering.</p> <p>Productivity- productivity measures- dynamics of productivity change- Techniques for improving productivity.</p> <p>Production costs concepts – Manufacturing Vs Purchase- problems- Economic aspects- C-V-P analysis – simple problems..</p> <p>Ergonomics Man-Machine systems-Anthropometry Work place design and ergonomics - Value Engineering</p>	7-2-0
2	<p>Work study-procedure-concept of work content- techniques to reduce work content.</p> <p>Method Study-steps-recording techniques-operation process chart-flow process chart-two hand process chart-multiple activity chart. Diagrams- Flow diagrams-String diagrams.</p> <p>Micro-motion study-SIMO chart- critical examination. Principle of motion economy.</p> <p>Work measurement- techniques of work measurement - Time Study- - Steps in time study- calculation of standard time (problems)- allowances</p>	7-2-0
3	<p>Plant location, plant layout and material handling- Type of layouts and characteristics – Tools and techniques for plant layout- travel chart – REL chart- Computer algorithms for layout design CRAFT-ALDEP (methods only)- Systematic layout planning -Line balancing–RPW (problem).</p> <p>Principles of material handling-selection and type of material handling equipment- Unit load concept- Automated Material Handling Systems- AGVs.</p> <p>Depreciation -Method of providing for depreciation- straight line method- Declining balance method- Sinking fund methods (Problems)</p>	7-2-0
4	<p>Production Planning and control -Types of Production systems.</p> <p>Demand forecasting- Forecasting methods, Aggregate planning- methods- Master Production Schedule-techniques-order promising- Material Requirement Planning-bill of material-product structure diagram- MRP record processing- Shop floor control - Scheduling flow shop and job shop scheduling methods, Johnson’s algorithm-dispatching rules -- Gantt charts.</p> <p>Introduction and need for a new product-product life cycle.</p> <p>Inventory Control, Inventory models – Basic model -price discounts -problems – determination of safety stock - Selective inventory control techniques</p>	7-2-0
5	<p>Quality control - Statistical quality control –causes of variation in quality- control charts for X and R (problems). Process Capability- process capability index- Reliability-causes of failures- Bath tub curve.-System reliability. Introduction to concepts of, TQM, ISO, Six Sigma and Quality circles.</p> <p>Project management- Critical Path Method, PERT, crashing of networks</p> <p>Determination of economic life -Replacement policy-- Methods of replacement analysis.</p>	7-2-0

---

SEMESTER VI

---

HONOURS

---

COURSE CODE	COURSE NAME	CATEGORY	L	T	P	CREDITS
22MEHR610.1	ADVANCED DESIGN SYNTHESIS	HR	3	1		4

Preamble:

- To give an overview of the techniques used in Mechanical Engineering for the analysis and synthesis of Mechanisms.
- To familiarize the graphical and analytical techniques commonly used in the synthesis of mechanisms.
- To provide sufficient theoretical background to understand contemporary mechanism design techniques.
- To develop skills for applying these theories in practice. Identify mechanisms by type of motion (Planar, Spatial etc.)
- Select the best type of mechanism for a specific application and apply the fundamental synthesis technique to properly dimension the mechanism

Course Outcomes: After the completion of the course the student will be able to

CO 1	Analyse Velocity and Acceleration Analysis of complex mechanisms using auxiliary points
CO 2	Solve the synthesis of slider crank mechanism with three accuracy points
CO 3	Explain the synthesis of slider crank mechanism with four accuracy points
CO 4	Describe the algebraic methods of synthesis using displacement equations
CO 5	Demonstrate the algebraic methods of synthesis using complex numbers

Mapping of course outcomes with program outcomes

	PO 1	PO 2	PO 3	PO 4	PO 5	PO 6	PO 7	PO 8	PO 9	PO 10	PO 11	PO 12
CO 1	3	3	2									
CO 2	3	3	2									
CO 3	3	3	2									
CO 4	3	3	2									
CO 5	3	3	2									

Assessment Pattern

Bloom's Category	Continuous Assessment Tests		End Semester Examination
	1	2	
Remember	10	10	10
Understand	20	20	20
Apply	20	20	70
Analyse			
Evaluate			
Create			

## Mark distribution

Total Marks	CIE	ESE	ESE Duration
150	50	100	3 hours

### Continuous Internal Evaluation Pattern:

Attendance : 10 marks

Continuous Assessment Test (2 numbers) : 25 marks

Assignment/Quiz/Course project : 15 marks

End Semester Examination Pattern: There will be two parts; Part A and Part B. Part A contain 10 questions with 2 questions from each module, having 3 marks for each question. Students should answer all questions. Part B contains 2 questions from each module of which student should answer any one. Each question can have maximum 2 sub-divisions and carry 14 marks.

### Course Level Assessment Questions

#### Course Outcome 1 (CO1):

1. Calculate Velocity and Acceleration Analysis of complex mechanisms using auxiliary points.
2. Describe Roberts – Chebyshev theorem.
3. Explain the Inflection circle, Euler- Savery equation, and Hartman construction.

#### Course Outcome 2 (CO2)

1. Describe about the Relative poles of four bar linkages and slider crank mechanism.
2. List out the usage of Function generators.
3. Execute the synthesis of slider crank mechanism with three accuracy points.

#### Course Outcome 3(CO3):

1. Execute the geometric methods of synthesis with four accuracy points.
2. Discuss about the Construction of circle points, Cardinal points, opposite poles, and Pole quadrilaterals
3. Do the synthesis of slider crank mechanism with four accuracy points.

#### Course Outcome 4 (CO4):

1. Demonstrate the algebraic methods of synthesis using displacement equations.
2. Execute the Crank and follower synthesis.
3. Describe the method to get angular velocities and accelerations from crank and follower synthesis.

Course Outcome 5 (CO5):

1. Discuss about the Algebraic methods of synthesis using complex numbers.
2. Explain the importance Spatial motion and spatial linkages.
3. Demonstrate working of the Simple mechanisms in Robots.

## MODEL QUESTION PAPER

SIXTH SEMESTER B. TECH DEGREE EXAMINATION  
Course Code: MET394

Course Name: ADVANCED DESIGN SYNTHESIS  
Max. Marks: 100  
Duration: 3 Hours

### PART – A

(ANSWER ALL QUESTIONS, EACH QUESTION CARRIES 3 MARKS)

1. State and explain Robert Chebychev theorem?
2. Explain the properties of inflection circle?
3. What are three accuracy points in cam and follower synthesis?
4. Explain the relative poles of slider crank mechanism with sketch?
5. What is the significance function generator in the design of a mechanism?
6. Explain pole quadrilateral in geometric synthesis?
7. Define center point and circle point?
8. Write notes on types of errors in synthesis?
9. Draw a simple robot mechanism?
10. Classify the various types of spatial mechanisms?

### PART – B

(ANSWER ONE FULL QUESTION FROM EACH MODULE)

#### MODULE – 1

11. For the twin cylinder V engine, determine the velocity of pistons B and D and the angular velocity of link 3. Link 2 rotates at 2000rpm. The dimensions of the various links are:  $O_2A = 50\text{mm}$  ;  $AB = BC = 150\text{mm}$  ;  $AC = 50\text{mm}$  ;  $CD = 125\text{mm}$

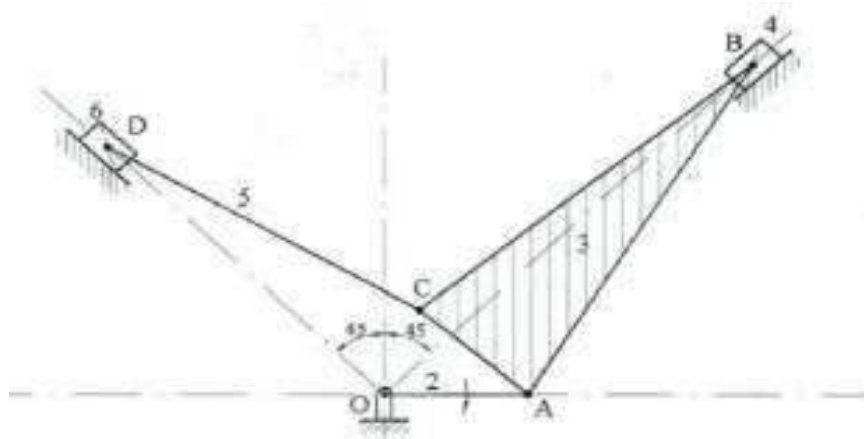

(14 marks)

12. Using overlay method and Chebychev spacing design a four-bar mechanism to generate the function  $y = x^{1.5}$  for  $0.5 < x < 1.5$ . Assume six precision points. (14 marks)

## Module 2

13. a) Discuss the significance of transmission angle in the design of a four-bar mechanism. (6 marks)
- b) Explain the procedure for design of a four-bar mechanism for optimum transmission angle. (8 marks)
14. Design a function generator linkage to solve  $y = 1/x$  in the range  $1 < x < 2$  using three precision points using geometric method.  $\Delta\Phi = 90^\circ$ ,  $\Delta\Psi = 90^\circ$ ,  $\Phi_0 = 90^\circ$ ,  $\Psi_0 = 45^\circ$ . Plot a curve of the desire function and the one generated by the synthesized linkage and find the maximum error percentage. (14marks)

## Module 3

15. Design a slider crank mechanism such that  $\Phi_{12} = 30^\circ$  and  $\Phi_{23} = 50^\circ$  and  $S_{12} = 25$  cm and  $S_{23} = 20$  cm using geometric method. The input crank moves in clockwise direction and the slider moves away from the crank pivot. (14 marks)
16. Design a double rocker mechanism to generate the function  $y = e^x$  in the range  $1 \leq x \leq 1$  using four precision points and Chebychev spacing using geometric method. (14 marks)

## Module 4

17. Synthesize a four-bar generator to generate the function  $y = \log_{10} x$  in the range  $1 \leq x \leq 2$  using algebraic method. Assume suitable starting angles and ending angles for motion of input and output links. Use three precision points and Chebychev spacing. Find out the maximum error. (14marks)
18. Synthesize a four-bar linkage to meet the following specification of position, velocity and acceleration
- |                                      |                                      |
|--------------------------------------|--------------------------------------|
| $\Phi = 60^\circ$                    | $\Psi = 90^\circ$                    |
| $\omega_\Phi = 5$ rad/s              | $\omega_\Psi = 2$ rad/s              |
| $\alpha_\Phi = 2$ rad/s <sup>2</sup> | $\alpha_\Psi = 7$ rad/s <sup>2</sup> |
- (14 marks)

## Module 5

19. Synthesize a four-bar linkage to satisfy the following specifications:  
 $\omega_2 = 200$  rad/s,  $\omega_3 = 85$  rad/s,  $\omega_4 = 130$ rad/s  
 $\alpha_2 = 0$  rad/s<sup>2</sup>,  $\alpha_3 = -1000$  rad/s<sup>2</sup>,  $\alpha_4 = -1600$  rad/s<sup>2</sup> (14 marks)
20. Compute the link lengths of a four-bar mechanism that will in one of its positions satisfy the following specifications:  $\omega_1 = 8$  rad/sec,  $\alpha_1 = 0$ ,  $\omega_2 = 1$  rad/sec,  $\alpha_2 = 20$  rad/sec<sup>2</sup>,  $\omega_3 = -3$  rad/sec,  $\alpha_3 = 0$ . (14 marks)

## Syllabus

### Module 1

Floating Link, Special methods of velocity and acceleration analysis using auxiliary points. Overlay method for conditioned crank mechanisms, coupler curves.

Roberts – Chebyshev theorem. Inflection circle, Euler- Savery equation, Hartman construction, Bobillier construction.

### Module 2

Synthesis using Optimum transmission angle.

Geometric methods of synthesis with three accuracy points: - poles of four bar linkages, Relative poles of four bar linkages, Function generators, poles of slider crank mechanisms, Relative poles of slider crank Mechanisms, Rectilinear recorder mechanisms.

Synthesis of slider crank mechanism with three accuracy points.

### Module 3

Geometric methods of synthesis with four accuracy points: - pole triangles, center point curves, Circle point curves, Construction of circle points, Cardinal points, opposite poles, Pole quadrilaterals,

Function Generators, Synthesis of slider crank mechanism with four accuracy points.

### Module 4

Algebraic methods of synthesis using displacement equations: - Crank and follower synthesis- three accuracy points.

Crank and follower synthesis- angular velocities and accelerations.

### Module 5

Rectilinear mechanisms, Algebraic methods of synthesis using complex numbers. Spatial motion and spatial linkages. Types of spatial mechanisms, Single loop linkage and multiple loop linkages. Simple mechanisms in robots.

### Text Books

1. Kinematic synthesis of Linkages by Richard.S.Hartenberg, Jacques Denavit, McGraw Hill book company. 1964
2. Kinematics and linkage design by Allen.S.Hall. Prentice Hall of India, Ltd. 1986
3. Theory of Mechanisms and Machines by Shigley, McGraw Hill International Edition., 4<sup>th</sup> edition, 2014
4. Dynamics of Machinery by A.R.Holowenko. John Wiley & Sons Inc, 1955



## Course Contents and Lecture Schedule

No	Topic	No. of Lectures
1	Module 1	
1.1	Floating Link, Special methods of Velocity and Acceleration Analysis using auxiliary points.	3
1.2	Overlay method for conditioned crank mechanisms, coupler curves. Roberts – Chebyshev theorem	3
1.3	Inflection circle, Euler- Savary equation, Hartman construction, Bobillier construction. Synthesis using Optimum transmission angle	3
2	Module 2	
2.1	Geometric methods of synthesis with three accuracy points: - poles of four bar linkages, Relative poles of four bar linkages,	3
2.2	Function generators, poles of slider crank mechanisms, Relative poles of slider crank Mechanisms, Rectilinear recorder mechanisms.	3
2.3	Synthesis of slider crank mechanism with three accuracy points.	3
3	Module 3	
3.1	Geometric methods of synthesis with four accuracy points: - pole triangles, center point curves,	3
3.2	Circle point curves, Construction of circle points, Cardinal points, opposite poles, Pole quadrilaterals,	3
3.3	Function Generators, Synthesis of slider crank mechanism with four accuracy points.	3
4	Module 4	
4.1	Algebraic methods of synthesis using displacement equations: - Crank and follower synthesis- three accuracy points	4
4.2	Crank and follower synthesis- angular velocities and accelerations	4
5	Module 5	
5.1	Rectilinear mechanisms, Algebraic methods of synthesis using complex numbers.	3
5.2	Spatial motion and spatial linkages	3
5.3	Types of spatial mechanisms, Single loop linkage and multiple loop linkages. Simple mechanisms in Robots.	3



## Assessment Pattern

Bloom's Category	Continuous Assessment			End Semester Examination
	Assignment (%)	Test 1 (%)	Test 2 (%)	
Remember	25	20	20	10
Understand	25	40	40	20
Apply	25	40	40	70
Analyse	25			
Evaluate				
Create				

## Mark distribution

Total Marks	CIE	ESE	ESE Duration
150	50	100	3 hours

## Continuous Internal Evaluation Pattern:

Attendance	: 10 marks
Continuous Assessment Test (2 numbers)	: 25 marks
Assignment/Quiz/Course project	: 15 marks

End Semester Examination Pattern: There will be two parts; Part A and Part B. Part A contain 10 questions with 2 questions from each module, having 3 marks for each question. Students should answer all questions. Part B contains 2 questions from each module of which student should answer any one. Each question can have maximum 2 sub-divisions and carry 14 marks.

## Course Level Assessment Questions

### Course Outcome 1 (CO1):

1. Represent various flow regimes on steady flow adiabatic ellipse.
2. List the various conservation laws governing the compressible flow
3. Define Mach cone and Mach Angle

### Course Outcome 2 (CO2)

1. Express stagnation enthalpy in terms of static enthalpy and velocity of flow
2. Explain the phenomenon of choking in isentropic flow.
3. Write applications of convergent nozzles and convergent-Divergent nozzles

### Course Outcome 3 (CO3):

1. Describe the phenomenon of frictional chocking
2. Differentiate between Fanno flow and Isothermal flow

3. Explain the significance of critical length in Fanno flow

Course Outcome 4 (CO4):

1. Explain the process of thermal choking in Rayleigh flow
2. Under what conditions the assumptions of Rayleigh flow is not valid in a heat exchanger
3. Locate the maximum enthalpy point in Rayleigh flow

Course Outcome 5 (CO5):

1. State and prove Prandtl-Mayer relationship for a normal shock wave.
2. What is an expansion fan? How does it occur in supersonic flow?
3. Explain why shock is impossible in subsonic flow.

Course Outcome 6 (CO6):

1. Name the various types of wind tunnels used for low and high speed testing of models
2. Difference between working principle of Shadowgraph and Schlieren techniques
3. Explain the working principle of constant current hot wire anemometer

### MODEL QUESTION PAPER

APJ ABDUL KALAM TECHNOLOGICAL UNIVERSITY

SIXTH SEMESTER MECHANICAL ENGINEERING

Compressible Fluid Flow -MET396

Maximum: 100 Marks

Duration: 3 hours

#### PART A

Answer all questions. Each question carries 3 marks

1. Derive an expression for stagnation temperature in terms of Mach number for compressible fluid flow.
2. Derive the condition at which flow become choked in isentropic flow?
3. Prove that Mach number is unity at the maximum entropy point on a Fanno curve.
4. Explain the significance of critical length in Fanno flow
5. What is Rayleigh flow? Explain Rayleigh flow with one practical case.
6. Under what conditions the assumptions of Rayleigh flow is not valid in a heat exchanger
7. Explain two situations where a normal shock wave is formed

8. Explain the formation of oblique shock wave in a concave corner and expansion fan in convex corner
9. Mention the difference in principle of the shadowgraph and Schlieren system
10. Explain with the help of sketches how yaw angle is eliminated in a Kiel probe.

(10 X 3 = 30 Marks)

## PART B

Answer one full question from each module

### MODULE 1

- 11.a. An air nozzle is to be designed for an exit Mach number of 2. conditions of the air available in the reservoir are 700 kPa, 533 K. Estimate i) pressure ii) temperature iii) velocity of flow iv) area, at throat and exit of the nozzle. Mass flow rate through the nozzle is 10000 kg/hr. 10 marks
- b. Derive an expression for area ratio in terms of Mach number for isentropic flow. Explain graphically the variation of area ratio with Mach number. 4 marks
- 12.a. Derive the conservation of mass equation for compressible flow through control volume approach. 4 marks
- b. A perfect gas having  $C_p = 1017.4 \text{ J/kg}$  and molecular weight 28.97 flows adiabatically in a converging passage with a mass flow rate of 27.20 kg/s. At a particular location,  $M = 0.5$ ,  $T = 500\text{K}$  and  $p = 0.25 \text{ MPa}$ . Calculate the area of cross section of the duct at the location.

10 marks

### MODULE II

- 13.a. A circular duct passes 8.25 kg/s of air at an exit Mach number of 0.5. The entry pressure and temperature are 3.45 bar and 38°C respectively and the mean coefficient of friction 0.005. If the Mach number at the entry is 0.15, determine i) diameter of the duct, ii) length of duct, iii) pressure and temperature at exit and iv) stagnation pressure loss. 8 marks
- b. Differentiate between Fanno flow and isothermal flow. Give one practical example each for Fanno flow and isothermal flow. 6 marks
- 14.a. Explain the phenomenon of choking in Fanno flow. 4 marks
- b. Air enters, a long circular duct of diameter 12 cm and mean coefficient of friction 0.0045, at a Mach number of 0.5, pressure 3.5 bar and temperature 300 K. If the flow is adiabatic throughout the duct, determine i) the length of the pipe required to change the Mach number to 0.6 ii) pressure and temperature of air at  $M=0.6$  iii) the length of the pipe required to attain limiting Mach number iv) pressure, temperature and Mach number at the limiting condition 10 marks

### MODULE III

- 15.a. Derive an equation describing a Rayleigh curve. Show that at maximum entropy point the flow is sonic. 6 marks

b. Data for entry of air at a constant area duct are  $p_1 = 0.35$  bar,  $T_1 = 300$  K, velocity of gas  $c_1 = 60$  m/s. If  $620$  kJ/kg of heat is added to the gas in the duct between entry and exit sections, determine at the exit i) pressure ii) temperature iii) Mach number iv) velocity of gas. How much heat is required to accelerate air from initial condition to sonic condition? 8 marks

16.a. Derive an expression for maximum possible heat transfer in Rayleigh flow in terms of Mach number. 7 marks

b. Air at Mach 1.5, pressure  $300$  kPa and temperature  $288$  K is brought to sonic velocity in a frictionless constant area duct through heat transfer. Determine the final pressure, temperature and heat added during the process. 7 marks

#### MODULE IV

17.a. Derive an expression for Mach number downstream of a normal shock 7 marks

b. The ratio of exit to entry area in a subsonic diffuser is  $3.3$ . The Mach number of a jet of air approaching the diffuser is  $2.1$ . Stagnation pressure of the jet is  $1.1$  bar and its static temperature is  $330$  K. There is a standing normal shock wave just outside the diffuser entry. The flow in the diffuser is isentropic. Determine pressure, temperature and Mach number at the exit of the diffuser. Also find the loss in stagnation pressure of the jet as it passes through the diffuser. 7 marks

18. a. What is an expansion fan? How does it occur in supersonic flow? 5 marks

18b. A stationary normal shock occurs in an air stream when the pressure, temperature and Mach number are  $85$  kPa,  $110$  °C and  $1.7$  respectively. Determine its density after the shock. Compare this value in an isentropic compression through the same pressure ratio. 9 marks

#### MODULE V

19 a. Explain the working of a shock tube with a neat sketch 8 marks

b. Explain the working of a constant current hot wire anemometer used for flow velocity measurement. 6 marks

20 a. Describe with the aid of a schematic diagram the working of a closed circuit supersonic wind tunnel. 7 marks

b. With a neat sketch explain the working of stagnation temperature probe. 7 marks

# Syllabus

## Module 1- FUNDAMENTALS OF COMPRESSIBLE FLOW & ISENTROPIC FLOW

Fundamentals of compressible flow: Concept of continuum-system and control volume approach- conservation of mass, momentum and energy- Mach number and its significance- Mach waves- Mach cone and Mach angle- physical difference between incompressible, subsonic, sonic and supersonic flows- static and stagnation states- relationship between stagnation temperature, pressure, density and enthalpy in terms of Mach number- Reference states in compressible fluid flows - adiabatic energy equation-representation of various flow regimes on steady flow adiabatic ellipse.

One Dimensional Isentropic flow: General features of isentropic flow- Comparison of adiabatic and isentropic process- One dimensional isentropic flow in ducts of varying cross-section- nozzles and diffusers- mass flow rate in nozzles- critical properties and choking- area ratio as function of Mach number- Impulse function- operation of nozzle under varying pressure ratios –over expansion and under expansion in nozzles-Applications of convergent divergent nozzles- Use of gas dynamics tables.

## Module 2 FANNO FLOW

Flow in constant area duct with friction (Fanno flow): Fanno curve and Fanno flow equations - Fanno line on h-s and p-v diagram- variation of flow properties- variation of Mach number with duct length- Chocking due to friction- isothermal flow in constant area duct with friction- Use of gas dynamics tables.

## Module 3 RAYLEIGH FLOW

Flow through constant area duct with heat transfer (Rayleigh Flow): Rayleigh line on h-s and p-v diagram-location of maximum enthalpy point- thermal choking-and maximum heat transfer-variations of flow properties- Use of gas dynamics tables.

## Module 4 NORMAL & OBLIQUE SHOCK WAVES

Normal shock Waves: Development of shock wave- governing equations- Strength of shock waves- Normal Shock on T-S diagram -Prandtl-Mayer relation, Rankine-Hugoniot relation- Mach number in the downstream of normal shock- variation of flow parameters across the normal shock -normal shock in Fanno and Rayleigh flows- working formula- curves and tables

Oblique shock waves: weak and strong oblique shocks-shock polar diagram-expansion waves- Reflection and intersection of oblique shocks and expansion waves

## Module 5 MEASUREMENT & VISUALIZATION TECHNIQUES

Compressible flow field measurement & visualization - Shadowgraph- Schlieren technique- interferometer- subsonic and supersonic flow measurement (Pressure, Velocity and Temperature) – compressibility correction factor- hot wire anemometer- Rayleigh Pitot tube- wedge probe- stagnation temperature probe- temperature recovery factor –Kiel probe - Wind tunnels – closed and open type- sub sonic – supersonic wind tunnels – shock tube.

## Text Books

1. Fundamentals of Compressible flow, S. M. Yahya, New age international Publication, Delhi

2. Fundamentals of compressible fluid dynamics- P. Balachandran, PHI Learning, New Delhi
4. Gas Dynamics, E. Rathakrishnan, PHI Learning Pvt. Ltd
5. Gas Dynamics and Jet Propulsion- P. Murugaperumal, Scitech Publication, Chennai.

Data Book

1. Yahya S. M., Gas Tables, New Age International.
2. Balachandran P., Gas Tables, Prentice-Hall of India Pvt. Limited.

Reference Books

1. The dynamics and thermodynamics of Compressible fluid flow Volume-I, Ascher H. Shapiro, the Ronald Press Company, New York.
2. Modern Compressible Flow: With Historical Perspective, John D. Anderson, McGraw-Hill Higher Education

**COURSE PLAN**

MODULE	TOPICS	HOURS ALLOTTED
1	Concept of continuum-system and control volume approach- conservation of mass, momentum and energy	3-1-0
	Mach number and its significance- Mach waves- Mach cone and Mach angle- physical difference between incompressible, subsonic, sonic and supersonic flows- static and stagnation states- relationship between stagnation temperature, pressure, density and enthalpy in terms of Mach number- stagnation velocity of sound- adiabatic energy equation- representation of various flow regimes on steady flow adiabatic ellipse	2-1-0
	General features of isentropic flow- performance curve- Comparison of adiabatic and isentropic process- One dimensional isentropic flow in ducts of varying cross-section- nozzles and diffusers- mass flow rate in nozzles- critical properties and choking- area ratio as function of Mach number- Impulse function- operation of nozzle under varying pressure ratios –over expansion and under expansion in nozzles-Applications of convergent divergent nozzles-Working charts and gas tables.	4-1-0
2	Fanno curve and Fanno flow equations - Fanno line on h-s and P-v diagram- solution of Fanno flow equations- variation of flow properties- variation of Mach number with duct length- Chocking due to friction- tables and charts for Fanno flow- isothermal flow in constant area duct with friction.	4-2-0
	Flow through constant area duct with heat transfer (Rayleigh Flow): Simple heating relation of a perfect gas- Rayleigh line on h-s and P-v diagram-location of maximum enthalpy point- thermal choking-and maximum heat transfer- variations of flow properties- tables and charts	



3	for Rayleigh flow.	4-2-0
4	Development of shock wave- Thickness of shock wave- governing equations- Strength of shock waves- Normal Shock on T-S diagram - Prandtl-Mayer relation, Rankine-Hugoniot relation- Mach number in the downstream of normal shock	4-1-0
	variation of flow parameters across the normal shock -normal shock in Fanno and Rayleigh flows- working formula- curves and tables	2-1-0
	weak and strong oblique shocks-shock polar diagram-expansion waves- Reflection and intersection of oblique shocks and expansion waves	2-1-0
5	Shadowgraph- Schlieren technique-interferometer	2-0-0
	subsonic and supersonic flow measurement (Pressure, Velocity and Temperature) – compressibility correction factor- hot wire anemometer- Rayleigh Pitot tube- wedge probe- stagnation temperature probe- temperature recovery factor –Kiel probe - Wind tunnels – closed and open type- sub sonic – supersonic wind tunnels – shock tube	3-0-0

COURSE CODE	COURSE NAME	CATEGORY	L	T	P	CREDITS
22MEHR610.3	ADVANCED NUMERICAL CONTROLLED MACHINING	HR	3	1		4

**Preamble:**

This course will help the student to understand the concept of numerical control and the peripheral requirements of the NC system. It familiarise the different approaches of machining using numerical control and also to make the student familiar to the different programming methods of NC machines.

Prerequisite: Nil

Course Outcomes: After the completion of the course the student will be able to

CO 1	To study the structure of numerical control and its applications
CO 2	To understand the features and control of CNC
CO 3	To write numerical part program of simple machining
CO 4	To familiarize the structure of computer assisted part programming features
CO 5	To study the constructional and automated features of numerical controlled machining

**Mapping of course outcomes with program outcomes**

	PO 1	PO 2	PO 3	PO 4	PO 5	PO 6	PO 7	PO 8	PO 9	PO 10	PO 11	PO 12
CO 1	2										2	2
CO 2	2				3							2
CO 3	3	2	2								2	1
CO 4	3				2							2
CO 5	3		2		3						1	2

**Assessment Pattern**

Bloom's Category	Continuous Assessment Tests		End Semester Examination
	1	2	
Remember	10	10	10
Understand	20	20	20
Apply	20	20	70
Analyse			
Evaluate			
Create			

## Mark distribution

Total Marks	CIE	ESE	ESE Duration
150	50	100	3 hours

### Continuous Internal Evaluation Pattern:

Attendance	: 10 marks
Continuous Assessment Test (2 numbers)	: 25 marks
Assignment/Quiz/Course project	: 15 marks

End Semester Examination Pattern: There will be two parts; Part A and Part B. Part A contain 10 questions with 2 questions from each module, having 3 marks for each question. Students should answer all questions. Part B contains 2 questions from each module of which student should answer any one. Each question can have maximum 2 sub-divisions and carry 14 marks.

### Course Level Assessment Questions

#### Course Outcome 1 (CO1):

1. Describe the structure of NC system
2. Enumerate difference between ordinary and NC Machine tools.
3. What is Machining Capabilities of a CNC Machine,.

#### Course Outcome 2 (CO2)

1. Differentiate open and closed loop control system
2. Enlist features of CNC and DNC system
- 3 Define the adaptive control system

#### Course Outcome 3(CO3):

- 1 Define the structure of CNC part programme
2. What is Programming using tool nose radius compensation ,Tools offsets
3. Enlist the procedure of manual Programming for simple parts

#### Course Outcome 4 (CO4):

1. Enumerate the structure of computer assisted part programming .
2. Generation of NC Programmes through CAD/CAM systems,.

3. Post processor design and implementation

Course Outcome 5 (CO5):

1. Machine structure of CNC machines
2. Constructional features of CNC turning center and CNC machining center
3. Design consideration of CNC machines

**MODEL QUESTION PAPER**  
**APJ ABDUL KALAM TECHNOLOGICAL UNIVERSITY**  
**SIXTH SEMESTER B.TECH DEGREE EXAMINATION**  
Course Code : MET398

Course Name : ADVANCED NUMERICAL CONTROLLED MACHINING  
Max. Marks : 100 Duration : 3 Hours

**PART – A**

*(ANSWER ALL QUESTIONS, EACH QUESTION CARRIES 3 MARKS)*

- 1 How does the structure of NC/CNC machine tools differ from conventional machine tools.
- 2 Explain clearly the difference between NC and CNC machine
- 3 Differentiate open loop and closed loop system in CNC machine.
- 4 Enumerate advantages and disadvantages of Direct numerical control
- 5 What is GO2 and GO3 in circular interpolation.
- 6 What is tool nose radius compensation and how to use it.
- 7 What is CAPP and discuss the benefits of CAPP
- 8 Discuss the code is used for canned cycle definition
- 9 Explain briefly swarf removal process in CNC machine.
- 10 What are the types of tools holders in CNC machine

**PART – B**

*(ANSWER ONE FULL QUESTION FROM EACH MODULE)*

**Module- 1**

- 11 a) With schematic diagram explain the basic principal of numerical. (8 Marks)
- b) Explain the historical development of numerical controlled machining (6 Marks)
- 12 a) Explain the machining capabilities of a CNC machine tool (7 Marks)
- b) Enlist and describe the advantages and dis advantages of CNC Machine (7 Marks)

**Module-2**

- 13 a) Describe the basic system of CNC machine tool (7Marks)
- b) Explain programming features of CNC system (7Marks)
- 14 a) What is adaptive control system in CNC machining and what is its benefits (7Marks)
- b) Describe the standard controllers of CNC machines (7Marks)

### Module-3

15 a) Explain the structure of NC part program (7Marks)

b) Describe the various programming functions of NC machining (7Marks)

16 a) Explain the fundamental element for developing manual part programme. (7Marks)

b) Describe various G code and M codes of NC programming. (7Marks)

### Module-4

17 Write the APT program of a given basic geometry element (14Marks)

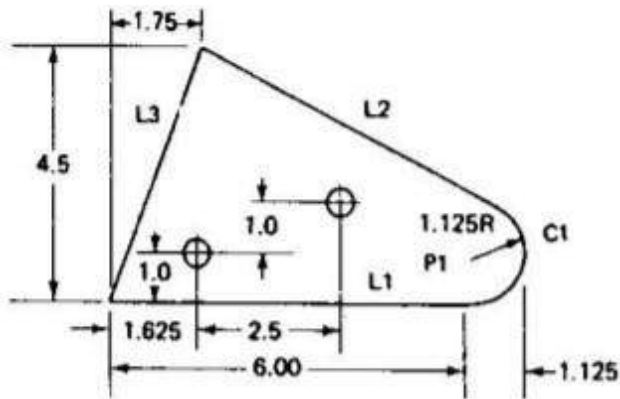

18 a) Explain the features CNC post processor. (8Marks)

b) Explain the generation of NC program through CAD/CAM system (6Marks)

### Module-5

19 a) Explain Automatic tool changers and multiple pallet systems in CNC system(7Marks)

b) Describe the constructional details of CNC turning centre (7Marks)

20 a) Explain various tooling requirement of CNC system (6Marks)

b) What is CNC tool holder and what are the different types (8Marks)

# Syllabus

## Module 1

Principles of Numerical Control Structure of NC systems, Applications of CNC machines in manufacturing, Advantages of CNC machines. Historical developments and future trends. Future of NC Machines, Difference between ordinary and NC Machine tools, Machining Capabilities of a CNC Machine, Methods for improving accuracy and productivity.

## Module 2

Control of NC Systems: Classification of CNC control systems Open and Closed loop systems, Types of CNC Machine Tools systems devices, e.g. encoders and interpolators, Features of CNC Systems, Direct Numerical Control (DNC), Standard Controllers and General Programming features available in CNC Systems, Computer Process monitoring and Control. Adaptive control systems.

## Module 3

NC Part Programming: Axis identification and coordinate systems ,Structure of CNC part program, Programming codes, Programming for 2 and 3 axis control systems ,Manual part programming for a turning center ,Programming using tool nose radius compensation ,Tools offsets ,Do loops, sub routines and fixed cycles. Manual Programming for simple parts.

## Module 4

Computer aided part programming; Tools for computer aided part programming, Computer aided NC Programming in APT language, use of canned cycles, Generation of NC Programmes through CAD/CAM systems, Design and implementation of post processors.

## Module 5

Constructional Details of CNC Machines: Machine structure ,Slide –ways ,Motion transmission elements ,Swarf removal and safety considerations ,Automatic tool changers and multiple pallet systems, Sensors and feedback devices in CNC machines ,Constructional detail of CNC turning center and CNC machining center. Tooling of CNC Machines Tooling requirements of CNC machines, Pre-set and qualified tools, Work and tool holding devices in CNC machines. Design considerations of CNC machines.

## Text Books

1. Radhakrishnan, P., “Computer Numerical Control Machines”, New Central Book Agencies
2. Mikell P. Groover., “ Automation, Production Systems and Computer Integrated Manufacturing”, Prentice Hall.

## Reference Books

1 YoramKoren, "Computer Control of Manufacturing Systems", Tata McGraw Hill Book Co.,2005.

2 HMT, Mechatronics, Tata McGraw-Hill Publishing Company Limited, New Delhi,1998.

## Course Contents and Lecture Schedule

No	Topic	No. of lectures
1	Module-1- Principles of Numerical Control	8 Hours
1.1	Structure of NC systems, Applications of CNC machines in manufacturing,	2 Hr
1.2	Advantages of CNC machines. Historical developments and future trends.	1 Hr
1.3	Future of NC Machines,	1 Hr
1.4	Difference between ordinary and NC Machine tools,	1 Hr
1.5	Capabilities of a CNC Machine	1 Hr
1.6	Methods for improving accuracy and productivity	2 Hr
2	Module 2-Control of NC Systems:	8 Hours
2.1	Classification of CNC control systems	1 Hr
2.2	Open and Closed loop systems,	1 Hr
2.3	Types of CNC Machine Tools systems devices, e.g. encoders and interpolators	1 Hr
2.4	Features of CNC Systems,	1 Hr
2.5	Direct Numerical Control (DNC),	1 Hr
2.5	Standard Controllers and General Programming features available in CNC Systems,	2 Hr
2.6	Computer Process monitoring and Control. Adaptive control systems.	1 Hr
3	Module-3- NC Part Programming	9 Hours
3.1	Axis identification and coordinate systems	1 Hr

3.2	Structure of CNC part program, Programming codes	2 Hr
3.3	Programming for 2 and 3 axis control systems	1 Hr
3.4	Manual part programming for a turning center	1 Hr
3.5	,Programming using tool nose radius compensation	1 Hr
3.6	Tools offsets ,Do loops, sub routines and fixed cycles	1 Hr
3.7	Manual Programming for simple parts	2 hr
4	Module-4- Computer aided part programming;	8 Hours
4.1	Tools for computer aided part programming	2 Hr
4.2	Computer aided NC Programming in APT language	2 Hr
4.3	use of canned cycles,	1 Hr
4.4	Generation of NC Programmes through CAD/CAM systems	2 Hr
4.5	, Design and implementation of post processors.	1 Hr
5	Module-5- Constructional Details of CNC Machines: Tooling of CNC Machines	12 Hours
5.1	Machine structure ,Slide –ways ,Motion transmission elements	2 Hr
5.2	Swarf removal and safety considerations	1 Hr
5.3	Automatic tool changers and multiple pallet systems	1 Hr
5.4	Sensors and feedback devices in CNC machines	1 Hr
5.5	Constructional detail of CNC turning center	2 Hr
5.6	CNC machining center and Tooling requirements of CNC machines	1 Hr
5.8	Pre-set and qualified tools and Work and tool holding devices in CNC machines	2 Hr
5.1 0	Design considerations of CNC machines.	2 Hr





---

# SEMESTER VII

---

COURSE CODE	COURSE NAME	CATEGORY	L	T	P	CREDITS
22MET701	DESIGN OF MACHINE ELEMENTS	ES	2	1	0	3

Preamble: This course focuses on important topics in design of machine elements. It covers the topics of shaft design with due consideration based on strength and rigidity. The course also includes the design procedure of flat belts and connecting rod of IC engines. The other topics included are journal bearings design, ball and roller bearings, spur gear and helical gear design considerations. The syllabus also covers design procedure of bevel gear and worm gear.

Prerequisite: MET304 Dynamics and Design of Machinery

Course Outcomes: After the completion of the course the student will be able to:

CO 1	Design shafts based on strength, rigidity and design for static and fatigue loads, design flat belts and connecting rod of IC engines
CO 2	Design clutches and brakes
CO 3	Analyse sliding contact bearings and understand design procedure of journal, ball and roller bearings.
CO 4	Design Spur gear and helical gear
CO 5	Design Bevel gears and worm gears

Mapping of course outcomes with program outcomes

	PO 1	PO 2	PO 3	PO 4	PO 5	PO 6	PO 7	PO 8	PO 9	PO 10	PO 11	PO 12
CO 1	3	3	3									
CO 2	3	3	3									
CO 3	3	3	3									
CO 4	3	3	3									
CO 5	3	3	3									

Assessment Pattern

Bloom's Category	Continuous Assessment Tests		End Semester Examination
	1	2	
Remember			
Understand	20	20	30
Apply	30	30	70
Analyse			
Evaluate			
Create			

### Mark distribution

Total Marks	CIE	ESE	ESE Duration
150	50	100	3 hours

### Continuous Internal Evaluation Pattern:

Attendance	: 10 marks
Continuous Assessment Test (2 numbers)	: 25 marks
Assignment/Quiz/Course project	: 15 marks

End Semester Examination Pattern: There will be two parts; Part A and Part B. Part A contain 10 questions with 2 questions from each module, having 3 marks for each question. Students should answer all questions. Part B contains 2 questions from each module of which student should answer any one. Each question can have maximum 2 sub-divisions and carry 14 marks.

### Course Level Assessment Questions

#### Course Outcome 1 (CO1):

1. What is critical speed of a shaft?
2. What are the causes of failure in shafts?
3. Differentiate between torsional rigidity and lateral rigidity of shaft.
4. Enumerate the various types of flat belt drives.
5. Explain why I section is usually preferred in the case of a connecting rod?

#### Course Outcome 2 (CO2)

1. What is the function of a clutch?
2. Why are cone clutches better than disc clutches?
3. What is the principle of operation of a centrifugal clutch? What are its applications?
4. What are the advantages and disadvantages of band brake?
5. What are the types of brake lining?

#### Course Outcome 3 (CO3):

1. Explain hydrodynamic theory.
2. Discuss the significance of bearing modulus in the design of journal bearing?
3. Briefly describe the design procedure of Journal bearings
4. Define static and dynamic load carrying capacity of ball bearing.

5. What is  $L_{10}$  and  $L_{50}$  life of ball bearing?

Course Outcome 4 (CO4):

1. State and explain law of gearing.
2. Give an account on different modes of failure of gear tooth.
3. Explain why dynamic factors need to be considered in the design of gears.
4. Explain interference and undercutting in gears
5. What are the advantages of helical gears over spur gears?
6. What is beam strength in case of helical gears?

Course Outcome 5 (CO5):

1. What are the uses of bevel gears?
2. Classify bevel gears.
3. What is formative number of teeth in case of bevel gears?
4. What are the characteristics of worm gears?
5. Enumerate the applications of worm gears?
6. Describe the design procedure of worm gears?

Model Question Paper

VII SEMESTER BTECH DEGREE EXAMINATION

MET401: DESIGN OF MACHINE ELEMENTS

Maximum: 100Marks

Duration:3 hours

*Use of Machine Design Data Book is permitted.*

PART A

Answer all questions, each question carries 3 marks

1. Compare the strength and stiffness of a hollow shaft of same outside diameter as that of a solid shaft.
2. Explain about the material for used for flat belts
3. How clutch is different from coupling?
4. What are the requirements for a good friction material used for the brakes?
5. What are the types of lubrication for bearings?
6. What are the causes of bearing failure?
7. Draw a neat sketch and indicate terminology used in spur Gear
8. What is virtual or equivalent number of teeth in case of helical gears?
9. What is a herringbone gear? What are its advantages?
10. Why a worm set can only be used as jack and hoists for raising loads. (10×3=30Marks)

PART B

*Answer one full question from each module*

MODULE 1

11. a) A shaft is supported by two bearings 1 m apart. A 600 mm diameter pulley is mounted at a distance of 300 mm to the right of left hand bearing and this drives a pulley directly below it with the help of a belt having maximum tension of 2.25 kN. Another pulley 400 mm diameter is placed 200 mm to the left of right hand bearing and is driven with the help of electric motor and belt, which is placed horizontally to the right. The angle of contact for both the pulley is 180° and  $\mu=0.24$ . Determine the suitable diameter for a solid shaft. The allowable working stress is 63 MPa in tension and 42 MPa in shear for the material of the shaft. Assume that the torque on one pulley is equal to that on the other pulley. (10 marks)
- b) Differentiate between torsional rigidity and lateral rigidity of shaft. (4 marks)

12. Design a flat belt drive for a compressor running at 670 rpm, which is driven by a 25 kW, 1340 rpm motor. Space is available for a centre distance of 3 m. The belt is open type. (14 marks)

### MODULE 2

13. a) Determine the main dimensions of a cone clutch faced with leather to transmit 30 kW at 750 rpm from an electric motor to an air compressor. Assume an over load factor of 1.75. Due to possibility of contamination of lining, a low value of coefficient of friction 0.2 is recommended. (11 marks)
- b) Distinguish between multiple plate clutch and cone clutch (3 marks)
14. a) A simple band brake as shown in figure below is to be designed to absorb a power of 32 kW at a rated speed of 850 rpm. Assume  $\mu = 0.25$ . Determine, (i) The effort required to stop clockwise rotation of the brake drum, (ii) The effort required to stop counter clockwise rotation of the brake drum, (iii) The dimensions of the rectangular cross-section of the brake lever assuming its depth to be twice the width, and (iv) the dimensions of the cross-section of the band assuming its width to be ten times the thickness. (10 marks)

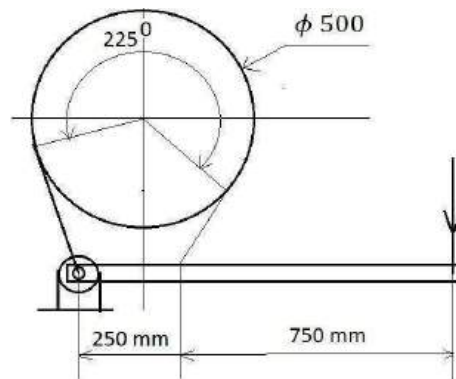

- b) What are the different types of brakes? (4 marks)

### MODULE 3

15. A  $360^\circ$  hydrodynamic journal bearing operates at 1200 rpm and carries a load of 5.5 k N. The journal diameter is 55 mm and length is 55 mm. The bearing is lubricated with SAE 20 oil and the operating temperature of oil is  $79^\circ\text{C}$ . Assume radial clearance as 0.025 mm and the attitude angle as  $60^\circ$ . Determine: (i) bearing pressure, (ii) Attitude, (iii) minimum film thickness, (iv) heat generated, (v) heat dissipated, if the ambient temperature is  $25^\circ\text{C}$ , and (vi) amount of artificial cooling if necessary. (14 marks)
16. a) A single row deep groove ball bearing has a dynamic load capacity of 40210 N and operates on the work cycle consists of radial load of 2000 N at 1000 rpm for 25 % of the time, radial load of 5000 N at 1500 rpm for 50 % of time, and radial load of 3000 N at

700 rpm for the remaining 25 % of time. Calculate the expected life of the bearing in hours. (10 marks)

b) Explain the mechanism of fluid film lubrication (4 marks)

#### MODULE 4

**17.** A motor shaft rotating at 1440 rpm has to transmit 15 kW power to a low speed shaft running at 500 rpm. A 20° pressure angle full depth involute system of gear tooth is used. The pinion has 25 teeth. Both gear and pinion are made of cast iron having allowable static strength of 55 MPa. Design a suitable spur gear drive and check the design for dynamic load and wear. (14 marks)

**18.** A helical gear speed reducer is to be designed. The rated power of the speed reducer is 75 kW at a pinion speed of 1200 rpm. The speed ratio is 3:1. For medium shock conditions and 24 hr operation, design the gear pair. The teeth are 20° full depth involute in the normal plane and helix angle is 30°. (14 marks)

#### MODULE 5

**19.a)** A pair of straight tooth bevel gears at right angles is to transmit 5 kW at 1200 rpm of the pinion. The diameter of the pinion is 80 mm and the speed reduction is 3.5:1. The tooth form is 20° full depth involute. Both the pinion and gear are made of cast iron with allowable stress of 55 MPa. Determine module and face width from the standpoint of strength. And also check the design from the standpoint of dynamic load and wear.

(14 marks)

**20.** Design a worm gear drive to transmit 20 HP from worm at 1440 rpm to the worm wheel that should be rotated at  $40 \pm 2\%$  rpm. (14 marks)



## Syllabus

### Module 1

Shafting:- material, design considerations, causes of failure in shafts, design based on strength, rigidity, and critical speed, design for static and fatigue loads, repeated loading, reversed bending.

Design of flat belt:- material for belts, slip of the belts, creep, centrifugal tension, Power transmitted by flat belts, Design procedure of flat belts

Design of connecting rod in IC engine.

### Module 2

Design of clutches: -single and multiple plate clutch, cone clutch, centrifugal clutch.

Design of brakes: -band brakes, block brakes, simple and differential band brake, internal expanding shoe brake.

### Module 3

Sliding contact bearing: - lubrication, lubricants, viscosity, journal bearings, hydrodynamic theory, Petroff's equation, bearing characteristic number, Sommerfeld number, Heat generated in bearings, Heat dissipated by bearings, Design procedure of Journal bearings.

Ball and roller bearings: - Types, bearing life, static and dynamic load capacity, Stribeck's Equation, selection of bearings, selection of taper roller bearings, Design procedure of Ball and roller bearings, Needle bearings.

### Module 4

Gears: - Materials of gears, terminology of spur Gear, Interference and undercutting, Gear tooth failures, Beam strength of Gear tooth, Estimation of module, Buckingham's equation for dynamic load, wear load, endurance strength of tooth, Gear proportions, Merits and demerits of each type of gears, Design procedure of Spur gear.

Helical gears: - Terminology, Virtual or equivalent number of teeth, Tooth proportions, Beam strength, and Wear strength of Helical gears, Design procedure of Helical gear

### Module 5

Bevel gears: - Classification, Terminology, Pitch angle for bevel gears, Strength of bevel gear, beam strength, wear tooth load, Formative number of teeth, Design procedure of Bevel gear.

Worm gears: - Characteristics of worm gears, Terminology, Advantages and disadvantages, Applications, Terms in Worm gear, Strength of Worm gear, Dynamic strength, Wear tooth load, Design procedure of Worm gear.

Design Data Books (permitted for reference in the university examination)

1. Mahadevan, K., and K. Balaveera Reddy, Design Data Handbook, Mechanical Engineers in SI and Metric Units. CBS Publishers & Distributors, New Delhi, 2018.
2. NarayanaIyengar B.R &Lingaiah K, Machine Design Data Handbook, Tata McGraw Hill/Suma Publications, 1984
3. PSG Design Data, DPV Printers, Coimbatore, 2012

Reference Books

1. J. E. Shigley, *Mechanical Engineering Design*, McGraw Hill, 2003
2. Jalaludeen, *Machine Design*, Anuradha Publications, 2016
3. V.B.Bhandari, *Design of Machine elements*, McGraw Hill, 2016
4. Juvinall R.C & Marshek K.M., *Fundamentals of Machine Component Design*, John Wiley, 2011
5. M. F. Spotts, T. E. Shoup, *Design of Machine Elements*, Pearson Education, 2006
6. RajendraKarwa, *Machine Design*, Laxmi Publications (P) LTD, New Delhi, 2006
7. Siegel, Maleev & Hartman, *Mechanical Design of Machines*, International Book Company, 1983

Course Contents and Lecture Schedule

Module	Topic	No. of Lectures
1.1	Shafting: - material, design considerations, causes of failure in shafts, design based on strength, rigidity, and critical speed, design for static and fatigue loads, repeated loading, reversed bending.	5
1.2	Design of flat belt:- material for belts, slip of the belts, creep, centrifugal tension, Power transmitted by flat belts, Design procedure of flat belts	3
1.3	Design of connecting rod in IC engine.	2
2.1	Design of clutches:-single and multiple plate clutch, cone clutch, centrifugal clutch	2
2.2	Design of brakes:-band brakes, block brakes, simple and differential band brake, internal expanding shoe brake.	3
3.1	Sliding contact bearing:- lubrication, lubricants, viscosity, journal bearings, hydrodynamic theory, Petroff's equation, bearing characteristic number, Sommerfeld number, Heat generated in bearings, Heat dissipated by bearings, Design procedure of Journal bearings.	4
3.2	Ball and roller bearings:- Types, bearing life, static and dynamic load capacity, Stribeck's Equation, selection of bearings, selection of taper roller bearings, Design procedure of Ball and	3

	roller bearings, Needle bearings.	
4.1	Gears:- Materials of gears, terminology of spur Gear, Interference and undercutting, Gear tooth failures, Beam strength of Gear tooth, Estimation of module, Buckingham's equation for dynamic load, wear load, endurance strength of tooth, Gear proportions, Merits and demerits of each type of gears, Design procedure of Spur gear.	5
4.2	Helical gears:- Terminology, Virtual or equivalent number of teeth, Tooth proportions, Beam strength, and Wear strength of Helical gears, Design procedure of Helical gear	3
5.1	Bevel gears:- Classification, Terminology, Pitch angle for bevel gears, Strength of bevel gear, beam strength, wear tooth load, Formative number of teeth, Design procedure of Bevel gear.	3
5.2	Worm gears:- Characteristics of worm gears, Terminology, Advantages and disadvantages, Applications, Terms in Worm gear, Strength of Worm gear, Dynamic strength, Wear tooth load, Design procedure of Worm gear.	2

---

SEMESTER VII

---

PROGRAM ELECTIVE II

---

COURSE CODE	COURSE NAME	CATEGORY	L	T	P	CREDITS
22MEE702.1	ADVANCED METHODS IN NON-DESTRUCTIVE TESTING	PROGRAM ELECTIVE II	2	1	0	3

**Preamble:**

1. To develop a fundamental knowledge about the advanced techniques and the recent developments in non-destructive testing so as to control the quality in manufacturing engineering components
2. To gain practical knowledge in non-destructive testing (NDT) processes and provide a detailed discussion on the advanced non destructive testing methods
3. To equip them with the knowledge of different NDT methods in complex geometries and enable them to select the appropriate methods for better evaluation.
4. To gain advanced knowledge of ultrasonic testing and X- ray radiography which enables them to perform inspection of samples.
- 5 To equip them with the knowledge of different NDT methods so as to control the quality in manufacturing of engineering components.

Prerequisite: NIL

Course Outcomes: After the completion of the course the student will be able to

CO 1	Understand the theoretical and practical knowledge in methods of non-destructive testing processes
CO 2	Understand the knowledge of advanced methods in ultrasonic testing which enables them to perform inspection of samples.
CO 3	Illustrate complete theoretical and practical understanding of the radiographic testing, interpretation and evaluation.
CO 4	Understand the recent advances in the field of non-destructive testing
CO 5	Outline the recent and advanced developments in radiography testing

**Mapping of course outcomes with program outcomes**

	PO 1	PO 2	PO 3	PO 4	PO 5	PO 6	PO 7	PO 8	PO 9	PO 10	PO 11	PO 12
CO 1	3		3			2	2	1	2			1
CO 2	3		3			2	2	1	2			1
CO 3	3		3			2	2	1	2			1
CO 4	3		3			2	2	1	2			1
CO 5	3		3			2	2	1	2			1

### Assessment Pattern

Bloom's Category	Continuous Assessment Tests		End Semester Examination
	1	2	
Remember	10	10	10
Understand	20	20	20
Apply	10	10	50
Analyse	10	10	20
Evaluate			
Create			

### Mark distribution

Total Marks	CIE	ESE	ESE Duration
150	50	100	3 hours

### Continuous Internal Evaluation Pattern:

Attendance	10 marks
Continuous Assessment Test (2 numbers)	25 marks
Assignment/Quiz/Course project	15 marks

End Semester Examination Pattern: There will be two parts; Part A and Part B. Part A contain 10 questions with 2 questions from each module, having 3 marks for each question. Students should answer all questions. Part B contains 2 questions from each module of which student should answer any one. Each question can have maximum 2 sub-divisions and carry 14 marks.

### Course Level Assessment Questions

#### Course Outcome 1 (CO1):

1. How visual inspection helps in non-destructive testing?
2. What is the use of field indicators in MPI?
3. What are the different types of developers? Describe the properties of good liquid penetrant.
4. What are the applications of eddy current testing?

Course Outcome 2 (CO2):

1. Describe the method of generating ultrasonic waves.
2. Explain the features of ultrasonic guided waves.
3. Describe the features of electromagnetic acoustic transducer .
4. Describe a method of detecting kissing bonds in friction stir welds of aero structures.

Course Outcome 3 (CO3):

1. Explain the radiography testing using Cobalt 60 isotopes.
2. Describe image quality indicators in Radiography testing.
3. Explain the principle of radiation.
4. How the quality of a good radiograph is assessed.

Course Outcome 4 (CO4):

1. Illustrate the procedure of phased array inspection.
2. Describe the techniques of Time of flight diffraction.
3. Explain the methods of structural health monitoring.
4. Explain the use of Synthetic aperture focussing technique.

Course Outcome 5 (CO5):

1. Describe a technique for inspecting and monitoring the behaviour of equipment and materials performing under stress.
2. Suggest a suitable inspection method for detecting potential problems in energised electrical components.
3. Explain the advantages of digital radiography in medical application compared to conventional x-ray film radiography.
4. Describe the applications of Computed Tomography in industry.

Model Question paper

Reg No.: _____		Name: _____	
Course Code: MET 413			
Course Name: Advanced methods in Non Destructive Testing			
Max. Marks: 100		Duration: 3 Hours	
PART A			
<i>(Answer all questions; each question carries 3 marks)</i>			Marks
1		Explain any three Visual aids used in visual inspection.	3
2		Describe the principle of liquid penetrant inspection.	3
3		What is Snell's law of critical angle?	3
4		What is laser shearography?	3
5		What is radiographic sensitivity?	3
6		What are the properties of X-rays?	3
7		What is neutron radiography?	3
8		Explain the concept of structural health monitoring.	3
9		Differentiate between digital radiography and computed tomography.	3
10		Describe the applications of thermography testing.	3
PART B			
<i>(Answer one full question from each module, each question carries 14 marks)</i>			
Module -1			
11	a)	With a simple sketch, explain any two magnetisation techniques used in magnetic particle inspection.	8
	b)	Explain the procedure of magnetic particle inspection of casting.	6



12	a)	With sketches, explain eddy current inspection process.	8
	b)	Explain various methods of liquid penetrant inspection.	6
Module -2			
13	a)	Explain the methods of generating ultrasonic waves.	8
	b)	Describe the features of Electro Magnetic Acoustic Transducer.	6
14	a)	Explain the concept of laser ultrasonics.	8
	b)	Explain various modes of display in ultrasonic testing.	6
Module -3			
15	a)	What are the safety measures to be followed in radiography testing?	8
	b)	What is sensitometry? Discuss the importance of characteristics curves.	6
16	a)	What is Real time radiography? Explain its advantages.	8
	b)	Explain the procedure of film processing in radiography testing.	6
Module -4			
17	a)	Explain the principle of phased array techniques.	8
	b)	Describe the theory of time of flight diffraction (TOFD).	6
18	a)	Explain the features of Flash radiography for material motion detection.	8
	b)	What are the applications of thermography testing?	6
Module -5			
19	a)	Explain the principle of acoustic emission inspection.	8
	b)	Explain any four types of leak testing..	6
20	a)	Describe two methods of thermography testing.	8
	b)	Explain the industrial applications of computed tomography.	6

## Syllabus

### Module 1

Visual Testing -Liquid Penetrant Testing-Magnetic Particle Testing- Magnetic Particle Testing Equipment- Eddy Current Testing – Selection of testing methods- Codes, Standards and Specifications.

### Module 2

Fundamentals of Ultrasonic Waves-- Snell's law and critical angles – Fresnel and Fraunhofer effects– wave propagation in other engineering materials. Generation of ultrasonic waves– contact testing, immersion testing. Ultrasonic Guided Waves- Basics of guided waves– Generation of guided waves–Introduction to Electro –Magnetic Acoustic Transducer(EMAT -Optical methods in Ultrasonics- Laser Ultrasonics –optical detection of ultrasound – measurement of in plane displacement and velocity – Laser shearography – Applications

### Module 3

Basic Principles of Radiography -Film Radiography -Radiographic Image Quality and Radiographic Techniques -Radiation Detectors and Safety - Principle of radiation- Special Radiographic Techniques and Interpretation of radiographs of Fluoroscopy-Real-time radiography – Principle of neutron radiography - – Principle and application of in-motion and flash radiography- Interpretation of radiographs:- Interpretation for welds, castings etc, applications, various case studies, Inspection standards - applicable codes, standards and specifications (ASME, ASTM, AWS, BS, IBR etc.)

### Module 4

Phased Array Techniques- Principles of phased array inspection – phased array probes and their characteristics – Phased array wedges – Focal law– Beam shaping, steering –Scanning with phased array probes- linear, sectorial, C scan. Time of Flight Diffraction Theory and principles of Time of Flight Diffraction (TOFD)–Data acquisition and interpretation– TOFD techniques – selection of probe angle– calibration and optimization, optimizing angles– flaw location and sizing– codes and standards–interpretation, evaluation, applications. Introduction to Synthetic Aperture Focusing Technique (SAFT). Structural Health Monitoring (SHM)-methods- strain gauging- genetic algorithm

### Module 5

Acoustic emission inspection-Leak Testing - -Thermographic NDE- Contact and non contact thermal inspection methods– Heat sensitive paints – Heat sensitive papers -Inspection methods – Infrared radiation and infrared detectors–thermo mechanical behavior of materials– IR imaging in aerospace applications-Digital Radiography and Computed Tomography (CT) -computed radiography(CR) and direct radiography (DR) -industrial CT.

### Text Books

1. J.Prasad and C. G. K. Nair, Non-Destructive Test and Evaluation of Materials, Tata McGraw-Hill Education, 2nd edition (2011).
2. . B.Raj, T. Jayakumar and M. Thavasimuthu, Practical Non Destructive Testing, Alpha Science International Limited, 3rd edition (2007).
3. J. L. Rose, Ultrasonic waves in solid media, Cambridge University Press, (2004).
4. A.S. Paipetis, T. E Matikas and D. G. Aggelis, Emerging Technologies in Non-Destructive Testing, CRC Press, (2012).

### Reference Books

1. X. P. V. Maldague, Nondestructive evaluation of materials by infrared thermography, Springer-Verlag, 1st edition, (1993)
2. Non-Destructive Examination and Quality Control, ASM International, Vol.17, 9th edition (1989)
3. J. Krautkramer and H. Krautkramer, Ultrasonic Testing of Materials, Springer, 4th edition (1990).
- 4.L. W. Schmerr, Fundamentals of Ultrasonic Phased Arrays, Springer, (2014)

### Course Contents and Lecture Schedule

No	Topic	No. of Lectures
1.1	Visual Testing Fundamentals of Visual Testing – vision, lighting, material attributes, environmental factors, visual perception, direct and indirect methods Liquid Penetrant Testing Principles – types and properties of liquid penetrants – developers – advantages and limitations of various methods - selection of penetrant method - Applicable codes and standards	3
1.2	Magnetic Particle Testing Theory of magnetism – ferromagnetic, paramagnetic materials – characteristics of magnetic fields	2
1.3	Magnetic Particle Testing Equipment Selecting the method of magnetization, inspection materials, magnetic particle inspection of castings and welding – Dry continuous method, wet residual method- Applicable codes and standards	2
1.4	Eddy Current Testing Generation of eddy currents – effect of change of impedance on instrumentation – properties of eddy currents – eddy current sensing elements, probes, type of coil arrangement Applicable codes and standards.	2
2.1	Fundamentals of Ultrasonic Waves Nature of sound waves, wave propagation in metals– modes of sound wave generation – longitudinal waves, transverse waves, surface waves, lamb waves– Snell's law and critical angles – Fresnel and Fraunhofer effects– wave propagation in other engineering materials.	2

2.2	Generation of ultrasonic waves Methods of ultrasonic wave generation – piezo electric effect, piezo electric materials and their properties – crystal cuts and mode of vibration – Ultrasonic search Units (transducers), types (straight, angle, dual)	2
2.3	Ultrasonic Inspection Methods and Equipment Principle of pulse echo method, through transmission method, resonance method – Advantages, limitations – contact testing, immersion testing.	2
2.4	Ultrasonic Guided Waves- Basics of guided waves– Generation of guided waves–Introduction to Electro –Magnetic Acoustic Transducer -EMAT Optical methods in Ultrasonics- Laser Ultrasonics –bulk wave and lamb wave generation mechanisms – optical detection of ultrasound – measurement of in plane displacement and velocity – Laser shearography – Applications	3
3.1	Basic Principles of Radiography - Radio isotopic sources X-ray source generation and properties – industrial X-ray tubes Film Radiography -X-ray film – structure and types for industrial radiography – sensitometric properties – use of film, characteristic curves (H & D curve).	2
3.2	Radiographic Image Quality and Radiographic Techniques Radiographic sensitivity –single and double wall Radiography – panoramic radiography-procedure shooting sketch/technique sheets	3
3.3	Radiation Detectors and Safety Special and SI Units of radiation – Principle of radiation	2
4.1	Special Radiographic Techniques and Interpretation of radiographs Principles and applications of Fluoroscopy/Real-time radioscopy – advantages and limitations –recent advances, intensifier tubes, vidicon tubes etc– Principle of neutron radiography - attenuation of neutrons - direct and indirect technique - advantages and limitations – Principle and application of in-motion and flash radiography. <i>Interpretation of radiographs:-</i> Interpretation for welds, castings etc, applications, various case studies, Inspection standards - applicable codes, standards and specifications (ASME, ASTM, AWS, BS, IBR etc.	3
4.2	Phased Array Techniques Principles of phased array inspection – phased array probes and their characteristics – Phased array wedges – Focal law– Beam shaping, steering –Scanning with phased array probes- linear, sectorial, C scan.	2
4.3	Time of Flight Diffraction Theory and principles of Time of Flight Diffraction (TOFD)–Data acquisition and interpretation–	2

	TOFD techniques – selection of probe angle– calibration and optimization, optimizing angles– flaw location and sizing– codes and standards–interpretation, evaluation, applications	
4.4	<i>Introduction to Synthetic Aperture Focusing Technique (SAFT)</i> .Structural Health Monitoring (SHM)-methods- strain gauging- genetic algorithm-	2
5.1	Acoustic emission inspection Principles and Theory – Signal Propagation – Physical Considerations – The AE Process Chain - Time Considerations – AE Parameters –AE testing during grinding – pipelines – steam turbines – AE location of faults in power transformers. .	2
5.2	Leak Testing Introduction to leak testing– objectives – terminologies – measurement of leakage –Types of leak – Types of flow in leaks – Principles of Fluid dynamics – Leak Testing of Pressure Systems Without and with a Tracer Gas – Halogen diode leak testing – Helium mass spectrometer leak testing and subsystems –Leak testing for special applications-standards.	2
5.3	Thermographic NDE Introduction and fundamentals to infrared and thermal testing– Heat transfer – Active and passive techniques – Lock in and pulse thermography– Contact and non contact thermal inspection methods– Heat sensitive paints – Heat sensitive papers – thermally quenched phosphors liquid crystals -Inspection methods – Infrared radiation and infrared detectors–thermo mechanical behavior of materials	3
5.4	Digital Radiography and Computed Tomography (CT) Principles of Digital Radiography-Methods of digital radiography – digitization of X-ray films – computed radiography(CR) and direct radiography (DR) – process of image formation in CR – comparison of film, CR and DR method. Computed Tomography – industrial CT.	2

COURSE CODE	COURSE NAME	CATEGORY	L	T	P	CREDITS
22MEE702.2	OPTIMIZATION TECHNIQUES AND APPLICATIONS	PROGRAM ELECTIVE II	2	1	0	3

Preamble: This course introduces the students to the concept of solving engineering problems by developing linear and non-linear mathematical models. The models involve objectives and constraints in terms of the relevant design variables. The student learns to apply a suitable mathematical programming technique to solve the developed model. The course includes Linear Programming, Integer Programming, Dynamic Programming, Classical Optimization and Metaheuristic techniques.

Prerequisite: Basic concepts of linear algebra.

Course Outcomes: After the completion of the course the student will be able to

CO 1	Formulate engineering problems as mathematical programming problems.
CO 2	Apply Simplex and dual Simplex methods to solve linear programming problems.
CO 3	Analyse the sensitivity of the model parameters
CO 4	Solve integer programming problems.
CO 5	Apply Dynamic Programming techniques to solve sequential optimization problems
CO 6	Apply classical optimization techniques and algorithms to solve nonlinear optimization problems.

Mapping of course outcomes with program outcomes

	PO 1	PO 2	PO 3	PO 4	PO 5	PO 6	PO 7	PO 8	PO 9	PO 10	PO 11	PO 12
CO 1	3	3	3	3	1							
CO 2	3	3	2	2	2							
CO 3	3	3	3	3	2							
CO 4	3	3	2	2	2							
CO 5	3	3	2	2								
CO 6	3	3	3	3								

Assessment Pattern

Bloom's Category	Continuous Assessment Tests		End Semester Examination
	1	2	
Remember			5
Understand			5
Apply	30	30	40
Analyse	10	10	20
Evaluate	10	10	20
Create			10

### Mark distribution

Total Marks	CIE	ESE	ESE Duration
150	50	100	3 hours

### Continuous Internal Evaluation Pattern:

Attendance	: 10 marks
Continuous Assessment Test (2 numbers)	: 25 marks
Assignment/Quiz/Course project	: 15 marks

End Semester Examination Pattern: There will be two parts; Part A and Part B. Part A contain 10 questions with 2 questions from each module, having 3 marks for each question. Students should answer all questions. Part B contains 2 questions from each module of which student should answer any one. Each question can have maximum 2 sub-divisions and carry 14 marks.

### Course Level Assessment Questions

#### Course Outcome 1 (CO1):

1. Consider a chocolate manufacturing company that produces only two types of chocolate – A and B. Both the chocolates require Milk and Choco only. Each unit of A requires 1 unit of Milk and 3 units of Choco, and each unit of B requires 1 unit of Milk and 2 units of Choco. The company kitchen has a total of 5 units of Milk and 12 units of Choco. On each sale, the company makes a profit of Rs 6 per unit A sold, and Rs 5 per unit B sold. Now, the company wishes to maximize its profit. Formulate the problem as a LPP and determine how many units of A and B should it produce respectively?
2. A person wishes to invest Rs.14,000. He has identified four investment opportunities. Investment 1 requires an investment of \$5,000 and has a present value (a time-discounted value) of \$8,000; Investment 2 requires \$7,000 and has a value of \$11,000; Investment 3 requires \$4,000 and has a value of \$6,000; and Investment 4 requires \$3,000 and has a value of \$4,000. Into which investments should he place his money so as to maximize the total present value?
3. Find the dimensions of a box of largest volume that can be inscribed in a sphere of unit radius.

#### Course Outcome 2 (CO2)

1. Solve the following LPP using simplex method.

$$\text{Minimize } Z = 4x_1 + x_2$$

Subject to:

$$3x_1 + x_2 = 3;$$

$$4x_1 + 3x_2 \geq 6;$$

$$x_1 + 2x_2 \leq 4;$$

$$x_1, x_2 \geq 0;$$

2. Show that the Big-M method will conclude that the following LPP has no feasible solution.

$$\text{Maximize } Z = 2x_1 + 5x_2$$

Subject to:

$$3x_1 + 2x_2 \geq 6;$$

$$2x_1 + x_2 \leq 2;$$

$$x_1, x_2 \geq 0;$$

3. Generate the dual simplex iterations for the LPP given below and find the solution.

$$\text{Minimize } Z = 5x_1 + 6x_2$$

Subject to :

$$x_1 + x_2 \geq 2;$$

$$4x_1 + x_2 \geq 4;$$

$$x_1, x_2 \geq 0;$$

Course Outcome 3(CO3):

1. The following LPP has an optimal solution of  $x_1 = 320$ ;  $x_2 = 360$  and Objective function value = 4360.

$$\text{Maximize } Z = 8x_1 + 5x_2$$

Subject to:

$$2x_1 + 1x_2 \leq 1000;$$

$$3x_1 + 4x_2 \leq 2400;$$

$$x_1 + x_2 \leq 700;$$

$$x_1 - x_2 \leq 350;$$

$$x_1, x_2 \geq 0.$$

Carry out sensitivity analysis to determine the range in which the objective function coefficients can vary keeping the current solution as optimal.

2. Determine the shadow price corresponding to the first constraint for the LPP given in the previous question.
3. Describe the concept of shadow price and reduced cost.

Course Outcome 4 (CO4):

1. Solve the following integer programming problem using Branch and Bound algorithm.

$$\text{Maximize } Z = 5x_1 + 4x_2;$$

Subject to:

$$x_1 + x_2 \leq 5;$$

$$10x_1 + 6x_2 \leq 45;$$

$$x_1, x_2 \geq 0, \text{ and integers.}$$

2. Solve the following integer programming problem using the cutting plane algorithm.

$$\text{Maximize } Z = 7x_1 + 10x_2$$

Subject to:

$$-x_1 + 3x_2 \leq 6;$$



$$7x_1 + x_2 \leq 35;$$

$$x_1, x_2 \geq 0, \text{ and integers.}$$

3. Solve the following integer programming problem.

$$\text{Maximize } Z = 2x_1 + 3x_2$$

Subject to:

$$5x_1 + 7x_2 \leq 35;$$

$$4x_1 + 9x_2 \leq 36;$$

$$x_1, x_2 \geq 0, \text{ and integers.}$$

Course Outcome 5 (CO5):

1. Find the shortest distance between the origin and destination for the network given below using dynamic programming.

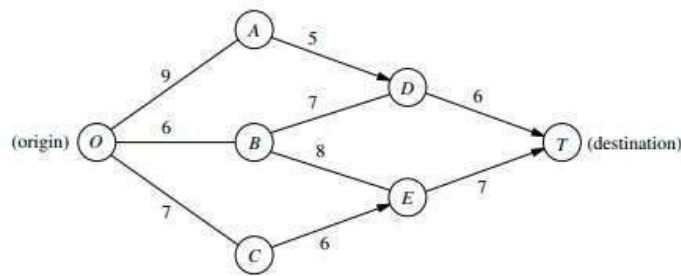

2. What is Bellman's principle of optimality?

3. A college student has 7 days remaining before the final examinations for four courses, and she wants to allocate this study time as effectively as possible. She needs at least 1 day on each course, and likes to concentrate on just one course each day. So she wants to allocate 1, 2, 3, or 4 days to each course. She decides to use dynamic programming to make these allocations to maximize the total grade points to be obtained from the four courses. She estimates that the alternative allocations for each course would yield the number of grade points shown in the table given below. Solve this problem using dynamic programming.

Study Days	Estimated grade points			
	Course 1	Course 2	Course 3	Course 4
1	3	5	2	6
2	5	5	4	7
3	6	6	7	9
4	7	9	8	9

Course Outcome 6 (CO6):

1. Maximize the function  $f(x_1, x_2, x_3) = x_1 + 2x_2 + x_2x_3 - x_1^2 - x_2^2 - x_3^2$

2. Find the solution for the following problem using the Lagrange multiplier method.

$$\text{Minimize } f(x, y) = 5x^{-1}y^{-2}$$

$$\text{subject to : } g(x, y) = x^2 + y^2 - 9 = 0$$

3. Use the Fibonacci search method to minimize the function

VII SEMESTER BTECH DEGREE EXAMINATION  
MET423: OPTIMIZATION TECHNIQUES AND APPLICATIONS

Maximum : 100 Marks

Duration : 3 hrs.

PART A

*Answer all questions. Each question carries 3 marks.*

1. How is degeneracy identified in the simplex procedure?
2. What is the role of artificial variables in simplex method?
3. Write the dual for the following LPP.

$$\text{Maximize } Z = 5x_1 + 4x_2;$$

Subject to:

$$x_1 + x_2 \leq 5;$$

$$10x_1 + 6x_2 \leq 45;$$

$$x_1, x_2 \geq 0.$$

4. What is meant by shadow price?
5. Explain the importance of integer programming models and their applications.
6. What is Bellman's principle of optimality?
7. Find the extreme points of the function
$$f(x) = 12x^5 - 45x^4 + 40x^3 + 5$$
8. State the necessary and sufficient conditions for the maximum of a multivariable function  $f(X)$ .
9. Find the Hessian matrix of the function  $f(x) = 3x_1^2x_2^2 - x_2^2x_3^3$
10. Describe the procedure of Golden Section search method.

PART B

*Answer one full question from each module*

Module 1

11. a) Consider a chocolate manufacturing company that produces only two types of chocolate – A and B. Both the chocolates require Milk and Choco only. Each unit of A requires 1 unit of Milk and 3 units of Choco, and each unit of B requires 1 unit of Milk and 2 units of Choco. The company kitchen has a total of 5 units of Milk and 12 units of Choco. On each sale, the company makes a profit of Rs 6 per unit A sold, and Rs 5 per unit B sold. Now, the company wishes to maximize its profit. Formulate the problem as a

LPP and graphically determine how many units of A and B should it produce respectively?

(5 Marks)

b) Use Simplex method to solve the following LPP.

$$\text{Minimize } Z = 4x_1 + x_2$$

Subject to:

$$3x_1 + x_2 = 3;$$

$$4x_1 + 3x_2 \geq 6;$$

$$x_1 + 2x_2 \leq 4;$$

$$x_1, x_2 \geq 0;$$

(9 Marks)

12. Solve the following LPP using Simplex method and carry out sensitivity analysis to determine the range in which the objective function coefficients can vary keeping the current solution as optimal.

$$\text{Maximize } Z = 8x_1 + 5x_2$$

Subject to:

$$2x_1 + 1x_2 \leq 1000;$$

$$3x_1 + 4x_2 \leq 2400;$$

$$x_1 + x_2 \leq 700;$$

$$x_1 - x_2 \leq 350;$$

$$x_1, x_2 \geq 0.$$

(14 Marks)

## Module 2

13. Generate the dual simplex iterations for the LPP given below and find the solution.

$$\text{Minimize } Z = 5x_1 + 6x_2$$

Subject to :

$$x_1 + x_2 \geq 2;$$

$$4x_1 + x_2 \geq 4;$$

$$x_1, x_2 \geq 0;$$

(14 Marks)

14. Solve the following integer programming problem using Branch and Bound algorithm.

$$\text{Maximize } Z = 2x_1 + 3x_2$$

Subject to:

$$5x_1 + 7x_2 \leq 35;$$

$$4x_1 + 9x_2 \leq 36;$$

$$x_1, x_2 \geq 0, \text{ and integers}$$

(14 Marks)

Module 3

15. Find the shortest distance between the origin and destination for the network given below using dynamic programming.

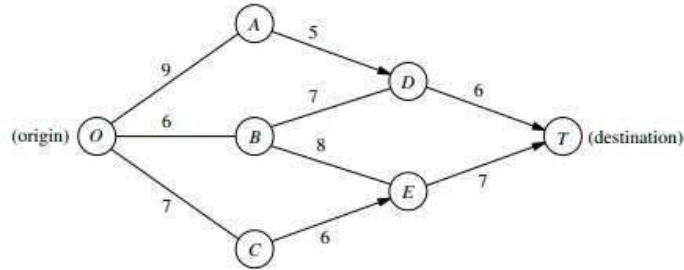

(14 Marks)

16. A candidate in an election wants to purchase TV time for a total of four commercials on TV stations located in four areas. Based on polling information, an estimate is made of the number of votes that can be won in the different areas depending upon the number of commercials run. These estimates are given in the table in thousands of votes. Use dynamic programming to find how the four commercials should be distributed among the four areas to maximize the estimated number of votes won.

Commercials	Area			
	1	2	3	4
0	0	0	0	0
1	4	6	5	3
2	7	8	9	7
3	9	10	10	12
4	12	11	12	14

(14 Marks)

Module 4

17. a) Find the extreme points of the function  $f(X) = x_1^3 + x_2^3 + 2x_1^2 + 4x_2^2 + 6$

(6 Marks)

- b) Find the maximum of the function  $f(X) = 2x_1 + x_2 + 10$ ; subject to  $g(X) = x_1 + 2x_2^2 = 3$  using the Lagrange multiplier method.

(8 Marks)

18. a) Find the dimensions of a box of largest volume that can be inscribed in a sphere of unit radius.

(6 Marks)

- b) Maximize the function  $f(x_1, x_2, x_3) = x_1 + 2x_2 + x_2x_3 - x_1^2 - x_2^2 - x_3^2$

(8 Marks)

## Module 5

19. a) Minimize the function  $f(x) = 0.65 - [0.75/(1+x^2)] - 0.65x \tan^{-1}(1/x)$  in the interval  $[0,3]$  using the Fibonacci method with  $n = 6$ . (7 Marks)

b) Use the steepest descent method to search for the minimum for the function  $f(x, y) = 25x^2 + y^2$ . Start at  $(1, 3)$  with a step size of 0.5 (7 Marks)

20. a) Use the golden section search method to minimize the function  $f(x) = x^4 - 14x^3 + 60x^2 - 70x$  in the range  $[0,2]$ . (7 Marks)

b) Solve  $\cos x = 2x$  using Newton Raphson method. Carry out 4 iterations. (7 Marks)

## Syllabus

### Module 1

Formulation of engineering problems as mathematical programming models: Linear Programming formulations.

Solutions to Linear Programming Problems: Simplex method – Big-M and 2-phase methods – Sensitivity Analysis for the objective function coefficients and right hand side coefficients of constraints - Exceptional cases in LPP.

### Module 2

Duality concept in LPP - Dual Simplex method.

Integer Programming problem: Applications of Integer Programming problems - Integer Programming algorithms - Cutting Plane method - Branch and Bound method.

### Module 3

Dynamic Programming: Bellman's principle of optimality - Forward recursion and backward recursion - Application problems- Shortest route and Knapsack problems.

### Module 4

Classical optimization techniques: Single variable optimization - Multivariable optimization with no constraints - Optimization with equality constraints - Method of Lagrange Multipliers - Optimization with inequality constraints - Kuhn-Tucker conditions.

### Module 5

Algorithms for unconstrained optimization: Fibonacci search method - Golden section search method -Hooke and Jeeve's method - Newton-Raphson method - Cauchy's (Steepest descent) method.

### Text Books

1. Hamdy A. Taha, “Operations Research, An Introduction”, Pearson Education, 10<sup>th</sup> edition, 2019.
2. S. S. Rao, “Engineering Optimization, Theory and Practice”, New Age International, 3<sup>rd</sup> edition, 2013

### Reference Books

1. N. V. S. Raju, “ Optimization Methods for Engineers”, Prentice-Hall of India, 1<sup>st</sup> edition, 2014
2. Ravindran, Philips and Solberg, “Operations Research, Principles and Practice”, Wiley, 2<sup>nd</sup> edition, 2007

### Course Contents and Lecture Schedule

No	Topic	No. of Lectures
1	Module 1	
1.1	Formulation of engineering problems as mathematical programming models.	1
1.2	Linear Programming models, Examples	1
1.3	Graphical method to solve LPP	1
1.4	Simplex method, Introduction	1
1.5	Example problems using Simplex method	2
1.6	Big-M method and 2-phase method	2
1.7	Sensitivity analysis	2
1.8	Exceptional cases	1
2	Module 2	
2.1	Duality concept in LPP	1
2.2	Dual Simplex method	2
2.3	Integer Programming problem – Introduction and applications.	1
2.4	Branch and Bound method	2
2.5	Cutting Plane method	2
3	Module 3	
3.1	Dynamic Programming- Introduction and Bellman’s principle of optimality	1
3.2	Forward recursion and backward recursion	1
3.3	Application problems -Shortest route problem	2
3.4	Knapsack problem	2
4	Module 4	
4.1	Classical optimization – Introduction- Single variable optimization	1
4.2	Multivariable optimization with no constraints	2
4.3	Optimization with equality constraints - Method of Lagrange	2

	Multipliers	
4.4	Optimization with inequality constraints - Kuhn-Tucker conditions.	2
5	Module 5	
5.1	Algorithms for unconstrained optimization- Introduction	1
5.2	Fibonacci search method	1
5.3	Golden section search method	1
5.4	Hooke and Jeeve's method	1
5.5	Newton-Raphson method.	1
5.6	Cauchy's (Steepest descent) method	1





### Assessment Pattern

Bloom's Category	Continuous Assessment Tests		End Semester Examination
	1	2	
Remember			
Understand	10	10	30
Apply	40	40	70
Analyse			
Evaluate			
Create			

### Mark distribution

Total Marks	CIE	ESE	ESE Duration
150	50	100	3 hours

### Continuous Internal Evaluation Pattern:

Attendance	: 10 marks
Continuous Assessment Test (2 numbers)	: 25 marks
Assignment/Quiz/Course project	: 15 marks

End Semester Examination Pattern: There will be two parts; Part A and Part B. Part A contain 10 questions with 2 questions from each module, having 3 marks for each question. Students should answer all questions. Part B contains 2 questions from each module of which student should answer any one. Each question can have maximum 2 sub-divisions and carry 14 marks.

### Course Level Assessment Questions:

#### Course Outcome 1 (CO1):

1. List various computational schemes involving Matrix methods for solution of boundary value problems.
2. List the mathematical strategies for converting (partial) differential equations into matrix equations.
3. Apply the direct method of FEM formulation to introduce Matrix methods in one-dimensional problems.
4. Apply the Principle of Total Potential energy to formulate FEM equations for 1-D spring element.

#### Course Outcome 2 (CO2)

1. Formulate the rotation matrix for coordinate transformation between local and global coordinates.
2. Assembly and solution for truss analysis.
3. Formulate stiffness matrix for beam problem.
4. Solution of beam problems using FEM.

#### Course Outcome 3(CO3):

1. Review of the constitutive matrix [D] for Plane-stress and Plane-strain cases.
2. Derivation of two-dimensional FEM equations for stress-analysis, using the Total Potential energy approach.
3. Formulate shape functions for some two dimensional elements.
4. Formulate strain-displacement gradient matrix [B] for the 3node triangular element (CST) and four node rectangular elements.
5. Assembly, application of boundary conditions and solution of problems involving CST.

#### Course Outcome 4 (CO4):

1. Demonstrate the motivation for Coordinate transformation using natural coordinates for formulations involving higher order elements.
2. Deduction of shape functions in terms of natural coordinates using Serendipity and Lagrange's Interpolation methods.
3. Perform Isoparametric formulation to derive stiffness matrix for (i) the general four node Quadrilateral element and (ii) eight node Quadrilateral element.
4. Perform Numerical integration in two-dimensions using Gauss Quadrature.
5. Illustration of solution of a structural problem for nodal unknowns, employing the above features (isoparametric formulation and Gaussian integration).

#### Course Outcome 5 (CO5):

1. Apply Galerkin's technique for FEM formulation.
2. Solve 1-D heat transfer problems employing FEM.
3. Formulate vibration problems using FEM
4. Solve Natural frequency (single degree of freedom, undamped) problems using FEM
5. Discuss practical aspects of FEM modelling.

Model Question Paper

MODEL QUESTION PAPER APJ ABDUL KALAM TECHNOLOGICAL  
UNIVERSITY

SEVENTH SEMESTER B.TECH DEGREE EXAMINATION

Course Code : MET433

Course Name : FINITE ELEMENT METHOD

Max. Marks : 100

Duration : 3 Hours

PART – A

(ANSWER ALL QUESTIONS, EACH QUESTION CARRIES 3 MARKS)

1. Compare and contrast FEM, FDM and FVM
2. Comment on the sources of errors in a FEM solution
3. What are local and global coordinates? How are they connected in a planar truss problem?
4. Explain the *Fixed end reactions method* in solving beam problems.
5. Make a short note on the Total potential energy method of formulating a FEM problem.
6. What are degrees of freedom in the context of an FEM element for structural analysis?
7. What is the motivation for coordinate transformation employing natural coordinates?
8. Evaluate the following integral using two-point Gauss Quadrature. Sampling points are at  $\pm 1/\sqrt{3}$ , and both weights are equal to unity.

$$\int_{-1}^1 (x^2 + 2x + 2) dx$$

9. How is the natural frequency of a system related to the eigen-value ?
10. Comment on the convergence of a static-structural FE simulation run.

PART – B

(ANSWER ONE FULL QUESTION FROM EACH MODULE)

MODULE – 1

11. For the assembly shown, formulate the global stiffness matrix, and equations (in matrix form) for the solution of the unknown global displacements and forces.  $P= 2\text{kN}$ ,  $k_1=1000\text{ kN/m}$ ,  $k_2=k_3=500\text{ kN/m}$ . (14 Marks)

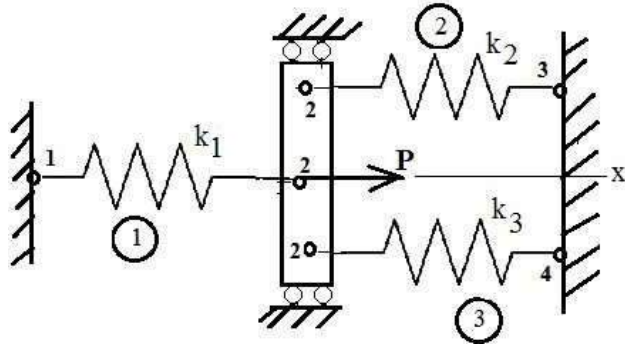

OR

12. Using Total Potential Energy Principle, derive the global stiffness matrix for the following assemblage of spring elements in series applied by a force (P) applied at node-4, along the x-axis. Subsequently, using the numerical values provided, find displacements at nodes 2 and 4, reaction forces at nodes 1 and 2, the force in each spring.  $P= 450 \text{ N}$ ,  $k_1=10,000 \text{ N/m}$ ,  $k_2=20,000 \text{ N/m}$ ,  $k_3=10,000 \text{ N/m}$ . (14 Marks)

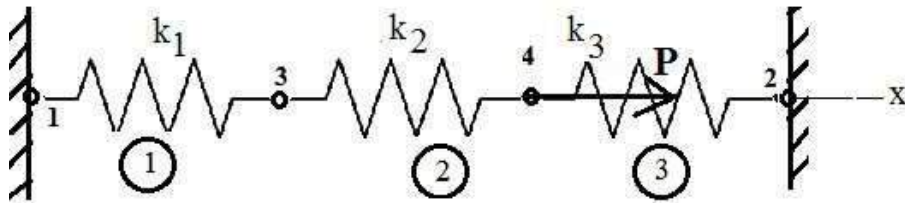

MODULE – 2

13. (a) Derive the stiffness matrix for an element for a planar truss problem in terms of the components of the rotation (transformation) matrix. (6 Marks)

(b) Determine the nodal displacements and rotations and the global and element forces for the beam supported and loaded as shown.  $E = 210 \text{ GPa}$ , Moment of inertia of cross-section,  $I = 2 \times 10^{-4} \text{ m}^4$ , and spring stiffness=  $200 \text{ kN/m}$ . (8 Marks)

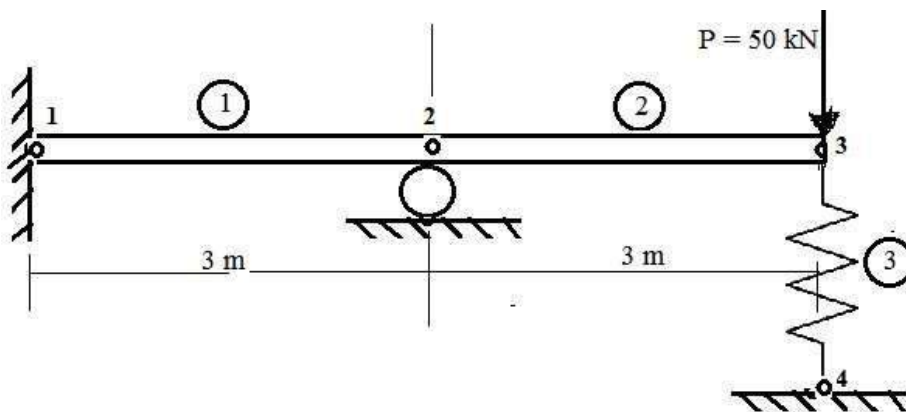

OR

14. (a) Derive the stiffness matrix for FEM analysis used to analyse beam problems based on Euler-Bernoulli theory. (5 Marks)

(b) Find stresses in the truss (rod) elements, if both rods have  $E = 210 \text{ GPa}$ , and area of cross section  $5.0 \times 10^{-2} \text{ m}^2$  (9 Marks)

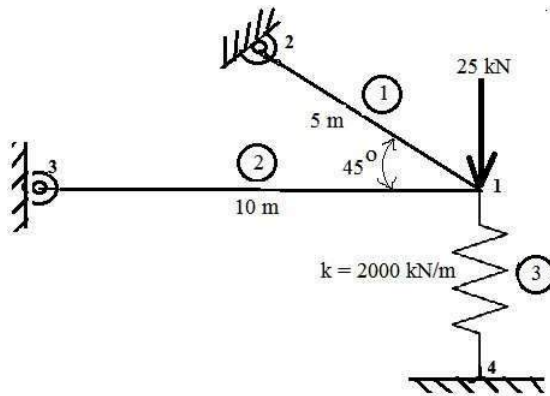

MODULE – 3

15. (a) Values for the field variable at the nodes (coordinates as indicated) of a triangular element are as shown. Assign appropriate node numbers and evaluate shape functions and calculate the value of the field variable at the coordinates (5,7). (9 Marks)

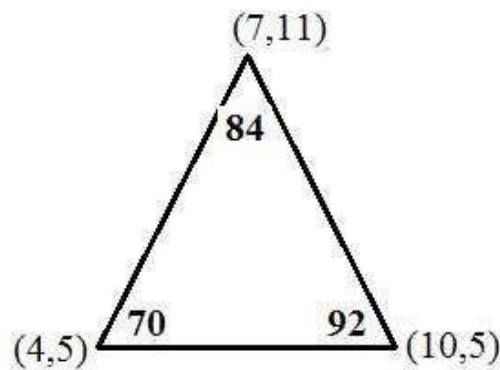

(b) For a 2D stress analysis problem employing a three noded triangular element, with vertices at (0,1), (0,-1) and (2,0), evaluate the Strain-Displacement Matrix. (5 Marks)

OR

16. (a) A thin plate as shown is pulled by a uniform load as shown. Should it be treated as a plane-stress problem or Plane strain problem? Justify. Accordingly, for the two-element

discretization shown, evaluate the Strain-Displacement Matrices and the Constitutive matrix.  $E = 200 \text{ GPa}$ , Poissons ratio is 0.3 and thickness  $t = 10 \text{ mm}$ . (9 Marks)

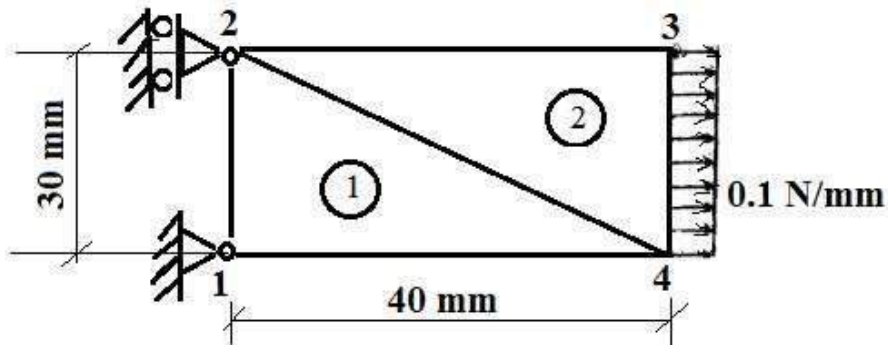

(b) What are the unknown variables at each node and the boundary conditions? How will you determine the stiffness matrix (need not compute the stiffness matrix)? Give the Load vector. (5 Marks)

#### MODULE – 4

17. (a) For a 4 node quadrilateral element for two dimensional stress analysis, derive expression for the Jacobian Matrix connecting the derivatives in  $(X, Y)$  and  $(\xi, \eta)$  coordinates (8 Marks)

(b) If the nodes of a quadrilateral with coordinates  $(x_1, y_1)$ ,  $(x_2, y_2)$ ,  $(x_3, y_3)$ ,  $(x_4, y_4)$ , are  $(20, 20)$ ,  $(40, 30)$ ,  $(50, 50)$  and  $(15, 40)$ , evaluate the Jacobian at  $\xi = 0.5$ ,  $\eta = 0.5$  (6 Marks)

OR

18. A bilinear rectangular element is loaded as shown. If the Jacobian at  $\xi = 1/3$ ,  $\eta = 1/3$  is given by  $\begin{bmatrix} 2 & 0 \\ 0 & 1.5 \end{bmatrix}$ , evaluate the corresponding B Matrix. (10 Marks)

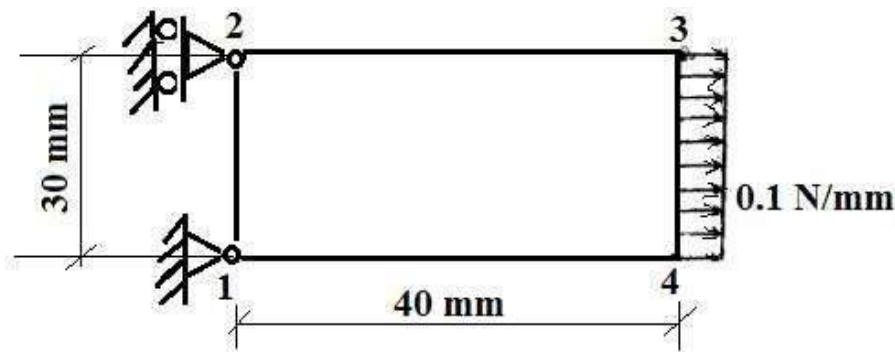

(b) What are the boundary conditions for this problem if the displacements at each node 'i' are represented as  $u_i$  and  $v_i$ . (1 Mark)

(c) If the problem is solved and displacements obtained, how can the strains be determined? And also, stresses? (solutions not intended) (3 Marks).

MODULE – 5

19. (a) Using the Galerkin's Weak formulation, derive the finite element equations for a one-dimensional steady state heat conduction problem with constant thermal conductivity and no heat generation. (8 marks)

(b) A heat transfer fin of radius 1cm and length 5 cm is attached to a boiler-wall maintained at 140°C and the other end is exposed to atmosphere. Find the temperature (at steady state) of the tip exposed to atmosphere and also at a point at 0.5 cm from the free end, by employing a two-element finite elements assembly. The curved surface of the fin is well insulated.  $T = 40^\circ\text{C}$ ,  $h = 10 \text{ W/cm}^2\text{C}$ .  $K = 70 \text{ W/cm}^\circ\text{C}$ . (6 marks)

OR

20. Derive the finite element equations for free vibration analysis due to axial displacements of rod elements using Galerkin's technique (8 marks)

(b) Determine the first two natural frequencies of longitudinal vibrations of the stepped steel bar shown. All dimensions are in mm.  $E = 200 \text{ GPa}$ ,  $\rho = 7800 \text{ N/m}^3$ , length  $L = 500 \text{ mm}$ . (6 marks)

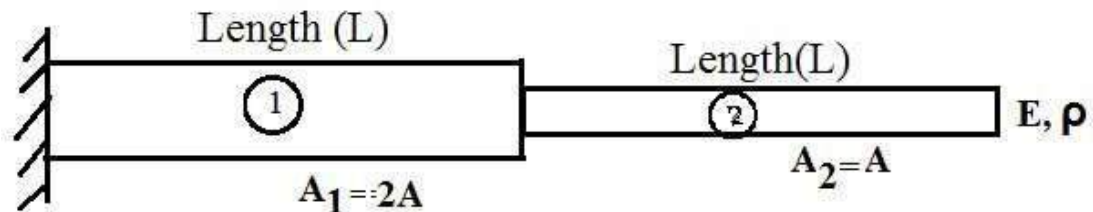

Syllabus

Module 1 (9 Hours)

FEM as a numerical computational tool in Computer Aided Design & Analysis- general features of numerical solutions-general strategy of Matrix Methods in Computational Mechanics- overview of similar numerical methods (FDM, FEM, FVM, BEM)-overview of general formulation methods leading to Matrix equations (Stiffness (direct) method, Potential energy method, Galerkin's etc.) - commercial and free FEM packages.

Direct approach of formulating the FEM equations for 1D stress problems:- element stiffness – assembly of elements – properties of  $[K]$  matrix – treatment of boundary conditions- stress computation – support reaction – simple problems.

Application of the Principle of Total Potential energy to formulate FEM equations for 1-D spring element. Simple problems involving assemblage of spring elements.

## Module 2 (8 Hours)

Plane truss element formulation – coordinate transformation – local and global coordinates – element matrices – assembly of elements – treatment of boundary conditions – stress calculation – Planar truss problems .

Beam element: Beam relationships – 1-D beam element FE formulation - element stiffness matrix – load considerations – boundary conditions – solution of problems.

## Module 3 (8 Hours)

Review of Constitutive Matrix [D] for Plane-stress and Plane-strain formulations- derivation of two-dimensional FEM equations for stress-analysis, using the Total Potential energy approach- Shape functions, equations for displacement field in terms of nodal displacements for (i) the 3-noded triangular element (CST) and (ii) four-node-rectangular elements. Strain-displacement gradient matrix [B] for the above elements- numerical problems involving 3-node-triangular elements.

## Module 4 (9 Hours)

Motivation for Coordinate transformation using natural coordinates, deduction of shape functions in terms of natural coordinates: Serendipity and Lagrange's Interpolation methods- Isoparametric formulation for (i) the general four- node- Quadrilateral element and (ii) eight-node- Quadrilateral element (curved boundaries)- Gauss Quadrature in 2-dimensions- Illustrative examples.

## Module 5 (7Hours)

Strong and Weak form , Galerkin's weighted residual FEM formulation ; One dimensional axially loaded bar, heat flow in a bar- numerical problems.

FEM formulation for (undamped) Natural frequency estimation in 1-D structural problems – simple examples.

Practical considerations in FEM analysis: aspect ratio and element types, use of symmetry in analysis, natural subdivisions at discontinuities, h and p methods of refinement, handling concentrated point loads and infinite stress in some geometries (re-entrant corners)-treatment of infinite medium, connecting different types of elements. Convergence of solution (demonstration of the above aspects in a FEM software environment recommended).

## Text Books

1. Daryl L. Logan, "A First Course in the Finite Element Method", Cengage Learning India Pvt. Ltd., 5<sup>th</sup> edition, 2012.
2. . Seshu P., "Textbook of Finite Element Analysis", PHI Learning Private Ltd., Ninth printing, 2010.



## Reference Books

1. Robert D Cook, David S Malkus, Michael E. Plesha and Robert J. Witt , “Concepts And Applications of Finite Element Analysis”, Wiley Student Edition, 4<sup>th</sup> Edition, 2007.
2. J. N. Reddy, “An Introduction to the Finite Element Method”, McGraw Hill International 4<sup>th</sup> Edition, 2018.
3. S. S. Rao, “The Finite Element Method in Engineering”, Butterworth-Heinemann Ltd; 3rd Revised edition, 1999.
4. K. J. Bathe, “Finite Element Procedures in Engineering Analysis”, Prentice Hall, Pearson Education Inc., 2<sup>nd</sup> edition, 2014.
5. O. C. Zienkiewics, R. L. Taylor, “The Finite Element Method,” Vol I & II, John Wiley & Sons Inc. 5th edition, 2000.

## Course Contents and Lecture Schedule

No	Topic	No. of Lectures
1	Module-1 ( 8 Hours)	
1.1	FEM as a numerical tool - general features of numerical solutions-general strategy of Matrix Methods.	1 Hour
1.2	Overview of FDM, FEM, FVM, BEM-overview of general formulation methods leading to Matrix equations.	1 Hour
1.3	Direct approach of formulating the FEM equations for 1D stressl problems:- element stiffness – assembly of elements – properties of [K] matrix – treatment of boundary conditions- stress computation – support reaction	2 Hours
1.4	Application of the Principle of Total Potential energy to formulate FEM equations for 1-D spring element.	1 Hour
1.5	Numerical Problems on direct method and Potential Energy Principle	3 Hours
2	Module-2 (6 Hours)	
2.1	Truss element formulation – coordinate transformation – local and global coordinates – element matrices	1 Hour
2.2	Assembly of elements – treatment of boundary conditions – stress calculation –Planar truss problems .	1 Hour
2.3	Tutorial on truss problems	1 Hour
2.4	1-D beam element FE formulation - element stiffness matrix –	1 Hour
2.5	Load considerations – boundary conditions for Beams	1 Hour
2.6	Tutorial on Beam problems	1 Hour
3	Module-3 (7 Hours)	
3.1	derivation of two-dimensional FEM equations for stress-analysis, using the Total Potential energy approach.	2 Hours
3.2	Shape functions, equations for displacement field in terms of nodal displacements for (i) the three-node-triangular element (CST) and (ii) four-node-rectangular elements.	2 Hours

3.3	Strain-displacement gradient matrix [B] for the above elements-	1 Hour
3.4	Tutorial Problems involving 3-node-triangular elements.	2 Hours
4	Module-4 (8 Hours)	
4.1	Coordinate transformation using natural coordinates, of shape functions in terms of natural coordinates: Serendipity and Lagrange's Interpolation methods.	2 Hours
4.2	- Isoparametric formulation for (i) the general four- node- Quadrilateral element and	2 Hours
4.3	Isoparametric formulation for (i) the general four- node- Quadrilateral element and (ii) eight-nod- Quadrilateral element (curved boundaries)	2 Hours
4.4	Gauss Quadrature in 2-dimensions- Illustrative examples.	1 Hour
4.5	Tutorial Problems involving isoparametric formulation.	1 Hour
5	Module-5 (7 Hours)	
5.1	Strong and weak form of simple problem	1 Hour
5.2	Galerkin's formulation of one dimensional axially loaded bar	1 Hours
5.3	Galerkin's formulation of one dimensional Heat flow in a bar	1 Hours
5.4	FEM formulation for (undamped) Natural frequency estimation in	1 Hour
5.5	Tutorial problems on 1-D problem	1 Hour
5.6	Practical considerations in FEM analysis and demonstration of these aspects in a FEM software environment.	2 Hours

COURSE CODE	COURSE NAME	CATEGORY	L	T	P	CREDITS
22MEE702.4	AEROSPACE ENGINEERING	PROGRAM ELECTIVE II	2	1	0	3

Preamble :This course provides fundamentals of aerospace engineering and understanding of flight instruments. To educate students the fundamental aerospace disciplines necessary to carry out the design of an aerospace vehicle or systems.

Prerequisite : Nil

Course Outcomes: After completion of the course the student will be able to

CO1	Explain the characteristics of atmosphere
CO2	Discuss airfoil theory, 2D, 3D or Finite aero foils
CO3	Explain perform analysis of flight dynamics of aircrafts
CO4	Understand different flight instruments
CO5	Discuss the principles of wind tunnel testing

Mapping of course outcomes with program outcomes

	PO 1	PO 2	PO 3	PO 4	PO 5	PO 6	PO 7	PO 8	PO 9	PO 10	PO 11	PO 12
CO 1	3	2	1									
CO 2	3	2										
CO 3	3	2	1									
CO 4	3	1										
CO 5	3	1										

Assessment Pattern

Bloom Category	Continuous Assessment Tests		End Semester Examination
	1	2	
Remember	10	10	10
Understand	20	20	20
Apply	20	20	70
Analyse			
Evaluate			
Create			

### Mark distribution

Total Marks	CIE	ESE	ESE Duration
150	50	100	3 hours

### Continuous Internal Evaluation Pattern:

Attendance	: 10 marks
Continuous Assessment Test (2 numbers)	: 25 marks
Assignment/Quiz/Course project	: 15 marks

End Semester Examination Pattern: There will be two parts; Part A and Part B. Part A contain 10 questions with 2 questions from each module, having 3 marks for each question. Students should answer all questions. Part B contains 2 questions from each module of which student should answer any one. Each question can have maximum 2 sub-divisions and carry 14 marks.

### Course Level Assessment Questions:

#### Course Outcome 1 (CO1):

1. What is meant by Standard atmosphere? Explain how the variation of pressure and density at different altitudes can be calculated.
2. With the help of a diagram explain the variation of temperature in different regions of atmosphere.

#### Course Outcome 2 (CO2):

1. Derive the expression for induced drag.
2. Write a summary of different drags that are acting on a 3D aerofoil.
3. With sketches compare the maximum lift produced by different high lift arrangements with that of a plane aerofoil.

#### Course Outcome 3 (CO3):

1. Derive the general two-dimensional translational equations of motion of an airplane in accelerated flight.
2. Explain how Froude's momentum theory can be used to calculate the efficiency of a propeller?
3. Show that at the velocity for minimum power required the airplane is flying at the angle of attack that corresponds to a maximum  $C_l^{3/2}/C_d$ .

#### Course Outcome 4 (CO4):

1. Explain the working of vertical speed indicator of an aircraft.
2. Explain the working of turn and bank indicator of an aircraft.
3. Explain the working of air temperature indicator of an aircraft.

Course Outcome 5 (CO5):

1. Explain the working of an indraft wind tunnel.
2. A low subsonic wind tunnel has a diffuser of area ratio 9. At a test section velocity of 30m/s and a temperature of 330K, the diffuser is found to have 90% efficiency. If the pressure at the inlet to the diffuser is  $1.195 \times 10^5 \text{N/m}^2$ . Calculate the head loss in the diffuser.
3. Explain the working of supersonic wind tunnel.

Model Question Paper

APJ ABDUL KALAM TECHNOLOGICAL UNIVERSITY

VIII SEMESTER B.TECH DEGREE EXAMINATION

MET443: AEROSPACE ENGINEERING

Maximum: 100 Marks

Duration: 3 hours

PART A

Answer all questions, each question carries 3 marks

1. Explain the variation of temperature in various regimes of earth's atmosphere.
2. Draw the pressure distribution around a 2-D aerofoil.
3. Explain span efficiency factor.
4. What is meant by aerodynamic center?
5. What are the various propeller coefficients?
6. Derive an expression for circular velocity.
7. Define the terms Range and Endurance of an aircraft?
8. How aerodynamic balancing of control surfaces is done in aircraft?
9. What do you mean by wind tunnel balances?
10. What is meant by range and endurance of an aircraft?

(10 X 3 = 30 marks)

PART B

Answer one full question from each module

Module 1

11. a) What do you mean by temperature, pressure and density altitudes? (4 marks)  
  
b) Consider an airplane flying at an altitude where the pressure and temperature are 25.37 Kpa and 216.66 K, respectively. Calculate the pressure and density altitudes at which the airplane is flying. (10 marks)
12. a) Explain how lift coefficient can be obtained from pressure coefficient. (4 marks)

b) An aircraft having wing span 9.6m and wing area 17m<sup>2</sup> produces a lift of 80,000N when flying at 120m/s. Calculate the induced drag when flying at sea level, Assume  $e=0.8$  (10 marks)

#### Module 2

13. a) An aircraft having wing span 9.6m and wing area 17m<sup>2</sup> produces a lift of 80000N when flying at 120m/s. Calculate the induced drag when flying at sea level, Assume  $e=0.8$  (10 marks)

b) Write some methods to reduce the wing tip vortices. (4 marks)

14. a) Explain Prandl's lifting line theory? (4 marks)

b) Explain how the prandl's lifting line theory can be used to calculate the aerodynamic characteristics of a finite wing. (10 marks)

#### Module 3

15. a) Derive the expression for thrust required for a level unaccelerated flight. (8 marks)

b) Obtain the condition for minimum thrust required for a level unaccelerated flight (6 marks)

16. a) What do you mean by power off glide? Derive the expression to find glide angle. (7 marks)

b) Derive the Brequet range equation for a propeller driven airplane (7 marks)

#### Module 4

17. a) What is meant by static and dynamic stability of an aircraft. (7 marks)

b) With Sketch, explain the working of airspeed indicator. (7 marks)

18. a) Explain the working and functions of different gyroscopic instruments used in aircrafts. (7 marks)

b) With the help of diagram, explain the working of different control surfaces of aircrafts. (7 marks)

#### Module 5

19. a) Explain the types of engines used for subsonic aircraft. (7 marks)

b) Define orbital velocity? Derive the expression for it. (7 marks)

20. a) Explain the working of an Indraft wind tunnel. (7 marks)

b) Briefly explain important space missions of ISRO. (7 marks)

## Syllabus

### Module 1

The atmosphere - characteristics of troposphere, stratosphere, thermosphere, and ionosphere - pressure, temperature and density variations in the atmosphere. Application of dimensional analysis – aerodynamic force – model study and similitude. 2D aero foils -Nomenclature and classification- pressure distribution in inviscid and real flows- momentum and circulation theory of aero foil- characteristics.

### Module 2

3D or finite aero foils – effect of releasing the wingtips- wing tip vortices- replacement of finite wing by horse shoe vortex system, lifting line theory-wing load distribution – aspect ratio, induced drag calculation of induced drag from momentum considerations. Skin friction and from drag- changes in finite wing plan shape

### Module 3

Propellers – momentum and blade element theories –propeller coefficients and charts. Aircraft performance-straight and level flight –power required and power available graphs for propeller and jet aircraft. Gliding and climbing –rate of climb-service and absolute ceilings-gliding angle and speed of flattest glide takeoff and landing performance – length of runway required- aircraft ground run- circling flight – radius of tightest turn-jet and rocket assisted take –off high lift devices-range and endurance of airplanes-charts for piston and jet engine aircrafts.

### Module 4

Flight Instruments-airspeed indicator, calculation of true air speed-altimeter, gyro horizon - direction indicator-vertical speed indicator –turn and bank indicator-air temperature indicator. (Brief description and qualitative ideas only). Ideas on stability-static and dynamic stability- longitudinal, lateral and directional stability- controls of an aero plane-aerodynamic balancing of control surfaces- mass balancing (Qualitative ideas only).

### Module 5

Principles of wind tunnel testing –open and closed type wind tunnels-wind tunnel balance supersonic wind tunnels. Study of subsonic, Transonic, and supersonic aircraft engines (Description with figures only).Elementary ideas on space travel-calculation of earth orbiting and escape velocities ignoring air resistance and assuming circular orbit.

### Text Books:

1. Anderson, Fundamentals of Aerodynamics, McGraw-Hill, 2010
2. A.C. Kermode, Mechanics of flight, Prentice Hall, 2007
3. EHJ Pallett, Aircraft Instruments and Integrated systems, Longman,1992

### Reference Books:

1. Houghton and Brock, Aerodynamics for Engineering Student, Hodder & Stoughton,1977

Course Contents and Lecture Schedule

No.	Topic	No. of Lectures
1	Module 1	
1.1	The atmosphere - characteristics of troposphere, stratosphere, thermosphere, and ionosphere - pressure, temperature and density variations in the atmosphere.	3
1.21.2	Application of dimensional analysis – aerodynamic force – model study and similitude	1
.21.3	2D aero foils -Nomenclature and classification- pressure distribution in inviscid and real flows- momentum and circulation theory of aero foil- characteristics.	3
2	Module 2	
2.1	3D or finite aero foils – effect of releasing the wingtips- wing tip vortices- replacement of finite wing by horse shoe vortex system, lifting line theory-wing load distribution – aspect ratio, induced drag calculation of induced drag from momentum considerations. Skin friction and from drag- changes in finite wing plan shape	7
3	Module 3	
3.1	Propellers – momentum and blade element theories – propeller coefficients and charts. Aircraft performance- straight and level flight –power required and power available graphs for propeller and jet aircraft.	4
1.23.2	Gliding and climbing –rate of climb-service and absolute ceilings-gliding angle and speed of flattest glide takeoff and landing performance – length of runway required- aircraft ground run- circling flight – radius of tightest turn- jet and rocket assisted take –off high lift devices-range and endurance of airplanes-charts for piston and jet engine aircrafts.	4
4	Module 4	
4.1	Flight Instruments-airspeed indicator, calculation of true air speed-altimeter, gyro horizon -direction indicator- vertical speed indicator –turn and back indicator-air temperature indicator.	4
4.1	Ideas on stability-static and dynamic stability- longitudinal, lateral and directional stability- controls of an aero plane- aerodynamic balancing of control surfaces- mass balancing	3
5	Module 5	



5.1	Principles of wind tunnel testing –open and closed type wind tunnels-wind tunnel balance supersonic wind tunnels. Study of subsonic, Transonic, and supersonic aircraft engines. Elementary ideas on space travel-calculation of earth orbiting and escape velocities ignoring air resistance and assuming circular orbit.	7
-----	--	---

COURSE CODE	COURSE NAME	CATEGORY	L	T	P	CREDITS
22MEE702.5	HYBRID AND ELECTRIC VEHICLES	PROGRAM ELECTIVE II	2	1	0	3

Preamble: This course aims to introduce the students to general overview of Hybrid Electric vehicle, Architecture of Hybrid Electric Drive Trains, control of various motors and drive with its different configuration. The course will also cover the power transmission of Electric vehicles and its components. The energy storage system with its management, charging methods and various sensors of Electric vehicles has been included. This course also covers the vehicle validation with its integration, Hardware & Software Interfaces, Chassis design, and Battery Positioning of Hybrid Electric vehicle.

Prerequisite: Nil

Course Outcomes: After the completion of the course the student will be able to

CO 1	Explain the general architecture of Electric vehicles
CO 2	Describe various motors and drives of Electric vehicles
CO 3	Explain details of power transmission of Electric vehicles and select the appropriate components based on requirement
CO 4	Describe charging, various sensors and battery management of Electric vehicles
CO 5	Apply vector tool simulation, do vehicle validation, chassis design and battery positioning of Electric vehicles

Mapping of course outcomes with program outcomes

	PO 1	PO 2	PO 3	PO 4	PO 5	PO 6	PO 7	PO 8	PO 9	PO 10	PO 11	PO 12
CO 1	3	1	1									
CO 2	3	2	1									
CO 3	3	1	1									
CO 4	3	2	1									
CO 5	3	3	2	2								

Assessment Pattern

Bloom's Category	Continuous Assessment Tests		End Semester Examination
	1	2	
Remember	10	10	10
Understand	20	20	20
Apply	20	20	70
Analyse			
Evaluate			
Create			

## Mark distribution

Total Marks	CIE	ESE	ESE Duration
150	50	100	3 hours

### Continuous Internal Evaluation Pattern:

Attendance	: 10 marks
Continuous Assessment Test (2 numbers)	: 25 marks
Assignment/Quiz/Course project	: 15 marks

End Semester Examination Pattern: There will be two parts; Part A and Part B. Part A contain 10 questions with 2 questions from each module, having 3 marks for each question. Students should answer all questions. Part B contains 2 questions from each module of which student should answer any one. Each question can have maximum 2 sub-divisions and carry 14 marks.

### Course Level Assessment Questions

#### Course Outcome 1 (CO1):

- 1 With the help of block diagram explain the major components of an electric vehicle
- 2 Explain the EV drivetrain alternatives based on power source configuration
- 3 Which are the resistive forces that retard the motion of a four-wheel vehicle? Show with a diagram

#### Course Outcome 2 (CO2)

- 1 How the electric motors used in EVs differs from that of used in industrial application
- 2 Explain the physical concept of torque production in Induction motor
- 3 Enlist the strategies for maintaining constant magnetic flux

#### Course Outcome 3(CO3):

- 1 What is field oriented control
- 2 Why higher number of gears are not used in Electric vehicle
- 3 Explain the single speed reduction in Electric vehicles

#### Course Outcome 4 (CO4):

- 1 Explain the battery charging and equalization
- 2 What is the importance of efficient battery thermal management in electric vehicle
- 3 Enlist different charging protocols in Electric vehicles

Course Outcome 5 (CO5):

- 1 What is the importance of electric vehicle validation
- 2 What is electric control unit in Electric vehicle
- 3 Where is the high voltage battery located in an electric vehicle

Model Question Paper

APJ ABDUL KALAM TECHNOLOGICAL UNIVERSITY  
SEVENTH SEMESTER B.TECH DEGREE EXAMINATION

Course Code : MET453

Course Name : Hybrid and Electric vehicles

Max. Marks : 100

Duration : 3 Hours

PART – A

*(ANSWER ALL QUESTIONS, EACH QUESTION CARRIES 3 MARKS)*

- 1 Differentiate between the design of Parallel HEV and Series HEV.
- 2 Identify the major components of the power train of a pure Electric vehicle.
- 3 Mention the type of electric motor suitable for an Electric vehicle. Substantiate your answer.
- 4 Give the sketch of a Brushless DC motor. Show the major parts in the sketch.
- 5 What are the basic switching elements used in EVs?
- 6 Give the significance of Power Speed Ratio as applied to an electric motor in an EV.
- 7 What is meant by a sensor? Identify any 3 sensors used in EVs and give their functions.
- 8 Explain how a regenerative braking system helps to increase the range of an EV.
- 9 Draw the basic architecture of CAN .Explain its function in HEV
- 10 What are the design issues encountered by a system integration engineer in HEV development ?

PART – B

*(ANSWER ONE FULL QUESTION FROM EACH MODULE)*

Syllabus

Module 1

- 11 a) With an example, explain the socio economic impact of EVs in the Indian Scenario  
(8 Marks)
- b) Why the first generation EVs had a premature death? In your opinion who is behind this ? .Give the facts to substantiate your answer.  
(6 Marks)

12 a)

Compute Forces due to drag, rolling resistance and gradient for the following vehicles assuming  $\rho = 1.2 \text{ (kg/m}^3\text{)}$  and  $\theta = 8^\circ$ . For the three vehicles given in the table, find Aerodynamic drag at velocity  $v_1$  and  $v_2$ ; also find rolling resistance at two velocities.

Vehicle	GVW (kg)	$C_D$	Area(sqm)	$\mu$	$v_1$ (kmph)	$v_2$ (kmph)	Tyre radius (m)
2-wheeler	200	0.9	0.6	0.015	30	80	0.28
3-wheeler	600	0.45	1.6	0.015	30	80	0.2
4-wheeler	1500	0.3	2.5	0.015	30	80	0.3

( 7 Marks)

b) What are the basic functions of a Power train ? Illustrate the concept in HEV scenario.

(7 Marks)

### Module 2

13 a) Differentiate between SPM and IPM based on Torque characteristics (8 Marks)

b) A vehicle is cruising at 36 kmph, the applied voltage is 25V, the BEMF is 24V and the winding resistance is 20 m $\Omega$

How much current is the motor drawing?

What is the power delivered to the vehicle?

What is the load torque due to the vehicle, reflected on the motor?

What is the efficiency of the motor?

If the applied voltage were increased by 1V, what will be the final speed of the vehicle?

(6 Marks)

14 a) What are the latest innovations in the design of high efficiency magnets ? Explain

(7 Marks)

b) What are the important losses during electric to mechanical conversion in EVs?

(7 Marks)

### Module 3

15) a) Why a gear system is needed in EVs ? Explain with a comparison with its ICE counterpart (7 Marks )

b) What are the basic function of a motor controller ? Explain its role in the performance of EV in various terrains (7 Marks)

16) a) Why gear optimization is needed in EVs ? Explain with a practical example.

(8 Marks )

b) An EV has a DC source but works on AC motor. Explain in detail how the conversion is carried out ? (6 Marks)

## Module 4

17 a) How battery selection is done in EVs? Explain by taking an Electric scooter as an example . (8 Marks)

b) A 3.5 V battery is at 2.7 V at SOC of 0% and 4.3 V at 100%. This implies the voltage of the battery lies in between  $3.5 \pm \Delta$  % volts . What is Delta? (6 Marks)

18 a) Explain the design procedure of a BMS for an E-rikshaw right from the requirements (10 Marks)

b) Explain active thermal management in battery pack design. (6 Marks)

## Module 5

19 a) Draw the electric diagram showing interconnections between a)ECU b)ABS sensor

c) Air conditioner using CAN protocol in HEV and explain its working (7 Marks)

b) What are the major hurdles faced in HEV integration? Explain by taking an Electric truck as an example (7 Marks)

20 a) What are the features differ in the design of chassis for a conventional ICE and HEV (7 Marks)

b) What are the challenges in the hardware /software interfacing in an HEV? Explain based on an example. (7 Marks)

## Syllabus

### Module 1

Introduction to Hybrid Electric Vehicles(HEV): History of hybrid and electric vehicles, social and environmental importance of hybrid and electric vehicles. Types of EVs, Review of Vehicle dynamics; Hybrid Electric Drive train. General configuration of Electric hybrid vehicles. Electric Vehicle (EV) Drive train Alternatives Based on Drive train Configuration.

### Module 2

Induction motors and drives, configuration, controls and applications in EV/HEV's; Permanent magnet motors-neodymium and ferrite and samarium cobalt types and drives configuration, Brushless DC Motor (BLDC), Interior Permanent magnet (IPM), Switch reluctance motors (SRM) W-Axial,3 phase Induction controls and applications in EV/HEV's

### Module 3

Motor Controllers/Inverters, Selection of automotive IGBT and MOSFET's, Field Oriented Control (FOC) & Space Vector Pulse Width Modulation (SVPWM) of Motors, Gearbox, selection of gear ratio, Different kinds of gearboxes, Gearbox optimisation, Transmission, Different kinds of transmission.

## Module 4

EV charging, Fast charger, DC charger, AC charger, Battery swapping, Different charging protocols CHAdeMO, CCS2, GB/T, Customised charging protocols, Battery Box Engineering, Battery Management Bus Bar design, Battery Pack Design, Various Sensors and Sensing methods, Battery Safety Standards, Thermal Management – Battery

## Module 5

Vehicle Validation, System Integration, Controller Area Networking (CAN) and Vector Tools Simulation, Vehicle Sensors specific to EV sensors interfaced to the ECU's in the vehicle network, Hardware & Software Interfaces and Implementation challenges and examples to solve, Chassis design, Battery Positioning.

### Text Books

1. Husain I, "Electric and Hybrid Vehicles": Design Fundamentals Boca Raton, CRC Press 2003

### Reference Books

1. James Larminie, John Lowry, Electric Vehicle Technology Explained, Wiley, 2003. 2.
2. Mehrdad Ehsani, Yimi Gao, Sebastian E. Gay, Ali Emadi, Modern Electric, Hybrid Electric and Fuel Cell Vehicles: Fundamentals, Theory and Design, CRC Press, 2004.
3. Iqbal Hussein, Electric and Hybrid Vehicles: Design Fundamentals, CRC Press, 2003.
4. Sandeep Dhameja, "Electric Vehicle Battery Systems", Newnes, 2000  
<http://nptel.ac.in/courses/108103009/>

### Course Contents and Lecture Schedule

No	Topic	No. of Lectures
1	Module 1	8 Hours
1.1	Introduction to Hybrid Electric Vehicles(HEV): History of hybrid and electric vehicles	2
1.2	social and environmental importance of hybrid and electric vehicles	1
1.3	Types of EVs,	1
1.4	Review of Vehicle dynamics;	2
1.5	Hybrid Electric Drive train. General configuration of Electric hybrid vehicles	1
1.6	Electric Vehicle (EV) Drive train Alternatives Based on Drive train Configuration.	1
2	Module 2	8 Hours
2.1	Induction motors and drives, configuration, controls and applications in EV/HEV's	2
2.2	Permanent magnet motors	1
2.3	neodymium and ferrite and samarium cobalt types and drives configuration	1
2.4	Brushless DC Motor (BLDC), Interior Permanent magnet (IPM),	

2.5	Switch reluctance motors (SRM	2
2.6	W-Axial,3 phase Induction controls and applications in EV/HEV's	1
	3 phase Induction controls and applications in EV/HEV's	1
3	Module 3	7 Hours
3.1	Motor Controllers/Inverters, Selection of automotive IGBT and MOSFET's	2
3.2	Field Oriented Control (FOC) & Space Vector Pulse Width Modulation (SVPWM) of Motors	1
3.3	Gearbox, selection of gear ratio, Different kinds of gearboxes	2
3.4	Gearbox optimisation, Transmission,	1
3.5	Different kinds of transmission	1
4	Module 4	7 Hours
4.1	EV charging, Fast charger, DC charger, AC charger, Battery swapping	1
4.2	Different charging protocols CHAdEMO,CCS2,GB/T, Customised charging protocols,	2
4.3	Battery Box Engineering, Battery Management	1
4.4	Bus Bar design, Battery Pack Design	1
4.5	Various Sensors and Sensing methods,	1
4.6	Battery Safety Standards, Thermal Management – Batter	1
5	Module 5	7 Hours
5.1	Vehicle Validation, System Integration	1
5.2	Controller Area Networking (CAN) and Vector Tools Simulation,	1
5.3	Vehicle Sensors specific to EV sensors interfaced to the ECU's in the vehicle network,	2
5.4	Hardware & Software Interfaces	1
5.5	and Implementation challenges and examples to solve	1
5.6	Chassis design, Battery Positioning	1



COURSE CODE	COURSE NAME	CATEGORY	L	T	P	CREDITS
22MEE702.6	OPERATIONS MANAGEMENT	PROGRAM ELECTIVE II	2	1	0	3

Preamble: This course is designed to facilitate the students to acquire knowledge about operations management concepts, tools and techniques. This course covers system concept of production, facility location analysis, facility layout, line balancing, demand forecasting, aggregate planning, material requirement planning and production scheduling. It empowers the students to amalgamate their knowledge and thus inculcate the skills needed to apply these concepts, tools and techniques in industry.

Prerequisite: Nil

Course Outcomes: After the completion of the course the student will be able to

CO 1	Understand operations, production system and perform facility location analysis.
CO 2	Impart knowledge of facility layout, layout planning and perform line balancing.
CO 3	Compute demand forecast and forecast accuracy.
CO 4	Perform aggregate planning and materials requirement planning.
CO 5	Apply various algorithms for production scheduling.

Mapping of Course Outcomes with Program Outcomes

	PO 1	PO 2	PO 3	PO 4	PO 5	PO 6	PO 7	PO 8	PO 9	PO 10	PO 11	PO 12
CO 1	2	2				1		1		1	2	2
CO 2	3	3	2	1	2					1	2	2
CO 3	3	3	2	1	1					1	2	2
CO 4	3	3	2		1					1	2	2
CO 5	3	3	2	1	1					1	2	2

Assessment Pattern

Bloom's Category	Continuous Assessment Tests		End Semester Examination
	1	2	
Remember	10	10	10
Understand	20	20	30
Apply	20	20	60
Analyse			
Evaluate			
Create			

### Mark Distribution

Total Marks	CIE	ESE	ESE Duration
150	50	100	3 hours

#### Continuous Internal Evaluation Pattern:

Attendance	: 10 marks
Continuous Assessment Test (2 numbers)	: 25 marks
Assignment/Quiz/Course Project	: 15 marks

End Semester Examination Pattern: There will be two parts; Part A and Part B. Part A contain 10 questions with 2 questions from each module, having 3 marks for each question. Students should answer all questions. Part B contains 2 questions from each module of which student should answer any one. Each question can have maximum 2 sub-divisions and carry 14 marks.

#### Course Level Assessment Questions

##### Course Outcome 1 (CO1):

1. Demonstrate the concept of operations management.
2. List the type of production system with examples.
3. Determine the location of a facility.

##### Course Outcome 2 (CO2):

1. List different types of facility layouts with examples.
2. Describe layout design procedures.
3. Group the activities for line balancing.

##### Course Outcome 3 (CO3):

1. Demonstrate need and uses of demand forecasting.
2. Compute demand forecast.
3. Compare demand forecasts from different methods.

##### Course Outcome 4 (CO4):

1. Compare aggregate planning strategies.
2. Demonstrate lot sizing techniques for MRP.

3. Compute MRP tables.

Course Outcome 5 (CO5):

1. Illustrate the concept of production scheduling.
2. Identify scheduling objectives might be appropriate for different manufacturing environments.
3. Find production schedule using various techniques.

Model Question Paper

APJ ABDUL KALAM TECHNOLOGICAL UNIVERSITY  
SEVENTH SEMESTER B. TECH DEGREE EXAMINATION

Course Code: MET463

Course Name: OPERATIONS MANAGEMENT

Max. Marks: 100

Duration: 3 Hours

PART A

(ANSWER ALL QUESTIONS, EACH QUESTION CARRIES 3 MARKS)

1. What are the criteria for make or buy decisions.
2. Explain how you would reengineer a process you find troubling.
3. How does a cellular layout combine a product and process layout?
4. State the basic differences between construction type and improvement type layout algorithms.
5. Describe the difference between short- and long-range forecasts.
6. What is the difference between a trend and a cycle and a seasonal pattern?
7. Differentiate between level production strategy and chase demand strategy.
8. What are the basic inputs for MRP?
9. Explain the concept of single machine scheduling problem.
10. What is Gantt chart and when are they used so often?

PART B

(ANSWER ONE FULL QUESTION FROM EACH MODULE, EACH QUESTION CARRIES 14 MARKS)

MODULE 1

11. What activities are involved in the operations function? How do operations interact with other functional areas?
12. A development company is attempting to determine the location for a new outlet mall. The region where the outlet mall will be constructed includes four towns, which together

have a sizable population base. The grid map coordinates of the four towns and the population of each are as follows:

Town	Coordinates		Population (10,000s)
	x	y	
1	30	60	6.5
2	50	40	4.2
3	10	70	5.9
4	40	30	3.5

- Determine the best location for the outlet mall using the centre-of-gravity method.
- Plot four towns and the location of the new mall on a grid map.

#### MODULE 2

13. Describe systematic layout planning. Narrate the steps of CRAFT and ALDEP.

14. Consider the following assembly network relationships of a product. The number of shifts per day is two and the number of working hours per shift is 8. The company aims to produce 80 units of product per day. Group the activities into workstations using rank positional weight method and compute balancing efficiency.

Operations Number	1	2	3	4	5	6	7	8	9	10
Immediate Preceding Tasks	-	1	1	1	2, 3	3, 4	5	5, 6	4, 6	7, 8, 9
Duration (min)	7	2	2	5	8	3	4	7	9	8

#### MODULE 3

15. What the effect on the exponential smoothing model will increasing the smoothing constant have? How does adjusted exponential smoothing differ from exponential smoothing? What determines the choice of the smoothing constant for trend in an adjusted exponential smoothing model?

16. The following table represents the sales data of milk (in litres) sold by a milk booth.

Month	1	2	3	4	5	6	7	8
Sales	90	106	92	114	108	98	99	115

- Compute a 3-month moving average forecast for months 4 through 9.
- Computer a weighted 3-month moving average forecast for months 4 through 9. Assign weights of 0.50, 0.30, and 0.20 to the months in sequence, starting with the most recent month.
- Compare the two forecasts using MAD. Which forecast appears to be more accurate?

#### MODULE 4

17. Describe the output of aggregate planning. When is aggregate planning most useful? Discuss the advantages and disadvantages of using part time workers, subcontracting work, and building up inventory as strategies for meeting demand.

18. Given the following Product structure, BOM, MPS and inventory status, compute MRP tables for all items.

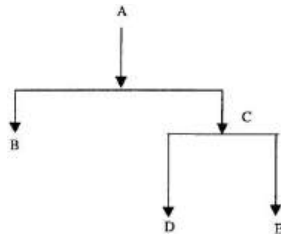

Product Structure

Bill of Materials

Part	Order Quantity	Lead Time (Week)	Inventory on Hand
A	350	1	220
B	400	2	250
C	800	1	120
D	850	1	105
E	250	1	250

Master Production Schedule

Month	1	2	3	4	5	6
Demand	200	-	-	240	150	220

MODULE 5

19. Define the term 'scheduling'. Explain the different performance measures in scheduling? Give examples of four types of operations and suggest which scheduling objectives might be appropriate for each.

20. Consider the following n jobs parallel identical machines problem

Job - j	1	2	3	4	5	6	7	8	9
$t_j$	5	21	16	6	25	19	20	10	6
$w_j$	3	2	4	2	4	3	1	2	1

Find the schedule which will minimize the weighted mean flow time, if the number of parallel identical machines is three.

## Syllabus

### Module 1

Introduction to operations management: operations function, operations strategy, system concept of production, types of production system – job shop production – batch production – mass production, process planning, make or buy decisions, process reengineering.

Facilities location: Facility location factors, location analysis techniques – location factor rating – center of gravity technique – load distance technique. (7 hours)

### Module 2

Capacities and facilities: capacity planning, facility layout – objectives, types of layout – process layout – product layout – fixed position layout – cellular layout, systematic layout planning, layout design procedures – CRAFT – CORELAP – ALDEP.

Assembly line balancing: methods for line balancing – rank positional weight method – COMSOAL. (7 hours)

### Module 3

Demand forecasting: need and uses of forecasting, components of forecasting demand, time series methods – moving average – weighted moving average – exponential smoothing – adjusted exponential smoothing – linear regression – seasonal adjustments, forecast accuracy. (7 hours)

### Module 4

Aggregate planning: aggregate planning strategies – heuristic method for aggregate planning.

Materials requirement planning: objectives, master production schedule, bill of materials, MRP calculations, lot sizing in MRP – economic order quantity method for lot sizing – minimum cost per period method – periodic order quantity method – least unit cost method, evolution from MRP to manufacturing resource planning (MRP II). (7 hours)

### Module 5

Introduction to production scheduling: objectives – processing characteristics and constraints – performance measures, Gantt chart, single machine scheduling – SPT rule to minimize mean flow time – EDD rule to maximum lateness, parallel processors – minimization of makespan – mean weighted flow time – McNaughton's algorithm, flow shop scheduling – extension of Johnson's rule for 3 machine problem – Palmer's heuristic. (7 hours)

### Text Books

1. Roberta S. Russell and Bernard W. Taylor III, Operations Management, John Wiley & Sons, Inc., Seventh Edition, 2011.
2. R. Paneerselvam, Production and Operations Management, PHI, 2010

## Reference Books

1. P. B. Mahapatra, Operations Management: A Quantitative Approach, PHI, 2010
2. G. Sreenivasan, Quantitative Models in Operations and Supply Chain Management, PHI.
3. Heizer and Render, Operations Management, Pearson Education, Eleventh Edition

## Course Contents and Lecture Schedule

No	Topic	No. of Lectures
1	Module 1	
1.1	Introduction to operations management: operations function, operations strategy, system concept of production, types of production system – job shop production – batch production – mass production.	3
1.2	Process planning, make or buy decisions, process reengineering.	2
1.3	Facilities location: Facility location factors, location analysis techniques – location factor rating – center of gravity technique – load distance technique.	2
2	Module 2	
2.1	Capacities and facilities: capacity planning, facility layout – objectives, types of layout – process layout – product layout – fixed position layout – cellular layout.	2
2.2	Systematic layout planning, layout design procedures – CRAFT – CORELAP – ALDEP.	3
2.3	Assembly line balancing: methods for line balancing – rank positional weight method – COMSOAL.	2
3	Module 3	
3.1	Demand forecasting: need and uses of forecasting, components of forecasting demand.	2
3.2	Time series methods – moving average – weighted moving average – exponential smoothing – adjusted exponential smoothing.	3
3.3	Linear regression – seasonal adjustments, forecast accuracy.	2
4	Module 4	
4.1	Aggregate planning: aggregate planning strategies – heuristic method for aggregate planning.	3
4.2	Materials requirement planning: objectives, master production schedule, bill of materials, MRP calculations, lot sizing in MRP – economic order quantity method for lot sizing – minimum cost per period method – periodic order quantity method – least unit cost method.	3
4.3	Evolution from MRP to manufacturing resource planning (MRP II).	1
5	Module 5	

5.1	Introduction to production scheduling: objectives – processing characteristics and constraints – performance measures, Gantt chart.	2
5.2	Single machine scheduling – SPT rule to minimize mean flow time – EDD rule to maximum lateness, parallel processors – minimization of makespan – mean weighted flow time – McNaughton’s algorithm.	3
5.3	Flow shop scheduling – extension of Johnson’s rule for 3 machine problem – Palmer’s heuristic.	2



COURSE CODE	COURSE NAME	CATEGORY	L	T	P	CREDITS
22MEE702.7	AIR CONDITIONING AND REFRIGERATION	PROGRAM ELECTIVE II	2	1	0	3

Preamble: The objectives of the course are:

- To introduce refrigeration and air conditioning systems.
- To impart knowledge in basics of vapour compression system and methods to improve efficiency.
- To understand working principle of vapour absorption refrigeration and steam jet refrigeration.
- To familiarize the components of refrigeration systems and to select environment friendly refrigerants
- To determine the capacity requirement of ac machine for an application.

Pre-requisite: MET 202 Engineering Thermodynamics.

Course Outcomes: After the completion of the course the student will be able to

CO 1	Explain the basics of refrigeration process.
CO 2	Analyse the vapour compression refrigeration system and to improve the performance.
CO 3	Describe vapour absorption and steam refrigeration system.
CO 4	Design refrigeration system by selecting suitable components and environmentally refrigerant.
CO 5	Evaluate the cooling load and capacity requirement of ac machine

Mapping of course outcomes with program outcomes

	PO 1	PO 2	PO 3	PO 4	PO 5	PO 6	PO 7	PO 8	PO 9	PO 10	PO 11	PO 12
CO 1	3			1								1
CO 2	3	2		2								1
CO 3	3	2		2								1
CO 4	3	1				2	3					1
CO 5	3	2	2				1					2

## Assessment Pattern

Bloom's Category	Continuous Assessment			End Semester Examination
	Assignment (%)	Test 1 (%)	Test 2 (%)	
Remember	25	20	20	10
Understand	25	40	40	20
Apply	25	40	40	70
Analyse	25			
Evaluate				
Create				

## Mark distribution

Total Marks	CIE	ESE	ESE Duration
150	50	100	3 hours

## Continuous Internal Evaluation Pattern:

Attendance	: 10 marks
Continuous Assessment Test (2 numbers)	: 25 marks
Assignment/Quiz/Course project	: 15 marks

End Semester Examination Pattern: There will be two parts; Part A and Part B. Part A contain 10 questions with 2 questions from each module, having 3 marks for each question. Students should answer all questions. Part B contains 2 questions from each module of which student should answer any one. Each question can have maximum 2 sub-divisions and carry 14 marks.

## Course Level Assessment Questions

### Course Outcome 1 (CO1):

1. Define COP of a refrigeration machine and heat pump?
2. What is a boot strap refrigeration system?
3. Why aircrafts prefer air refrigeration system?

### Course Outcome 2 (CO2)

1. Explain Vapour refrigeration system with the help of pressure- enthalpy diagram?
2. Explain flash inter-cooling method of improving efficiency of vapour compression system?

3. Explain cascade system with the help of neat diagram?

Course Outcome 3 (CO3):

1. Describe steam jet refrigeration system with the help of neat diagram?
2. Explain Lithium Bromide water absorption system. What are the advantages over ammonia absorption system?
3. Compare vapour absorption system with vapour compression system?

Course Outcome 4 (CO4):

1. Explain ODP and GWP of a refrigerant?
2. Explain scroll compressor with the help of neat sketch?
3. Explain the working principle and use of cooling tower with the help of a neat sketch?

Course Outcome 5 (CO5):

1. An Auditorium has seating capacity 800 people is to be maintained at 23°C DBT and 50% RH. The outdoor conditions are 40°C DBT and 27°C WBT. The various loads in the office are: Solar heat gain 10KW, sensible heat gain per occupant 80W, Latent heat per occupant 70W, Lighting load 5KW, Sensible heating load from other sources 12KW, Infiltration load 0.3m<sup>3</sup>/sec. Outdoor air and return air is mixed in the ratio of 1: 6, before cooling coil (processing unit) and then supplied to room. The supply temperature cannot be lower than 12°C. Find capacity of the plant required, mass flow rate of air?
2. What is ESR, ISEER, GSHF and RSHF? Explain?
3. Explain different psychrometric process and represent it in a psychrometric chart?

Model Question Paper

MET 473- AIR CONDITIONING AND REFRIGERATION.

Maximum: 100 Marks

Duration: 3 hours

PART A

Answer all questions. Each question carries 3 marks

1. Define COP of a refrigeration machine and heat pump?
2. Why aircrafts prefer air refrigeration system?
3. Explain Vapour refrigeration system with the help of pressure- enthalpy diagram?
4. Write sub cooling of condenser out let method improving COP of vapour compression system with the help of p-h diagram.
5. Compare vapour absorption system with vapour compression system?
6. Compare steam jet refrigeration system with vapour compression system?
7. Explain ODP and GWP of a refrigerant?
8. Explain the method of detection of leakage of refrigerant?
9. What are ESR, ISEER, GSHF and RSHF?
10. What is IPLV of an air conditioner? (10 X 3 = 30 Marks)

PART B

Answer one full question from each module

MODULE 1

11. a.Explain the application of refrigeration? 4 marks
- b. A boot strap air refrigeration system is used for a flight to takes 20 TONS of cooling loads. The ambient conditions are air conditions are  $5^{\circ}\text{C}$  and 0.85 Bar. The air pressure increases to 1.1 bars due to ramming action, which is considered to be ideal. The output pressure of the main air compressor is 3.5 Bar and this is further compressed in the secondary compressor to 4.5 Bar. The isentropic efficiency of both main and secondary compressors is 90% and that of cooling turbine is 80%. Heat exchanger effectiveness is 0.6, for both primary and secondary heat exchangers.Determine: Power required taking the cabin load; COP of the system, the turbine runs the secondary compressor and uses its surplus power to run the fan for blowing ram air, Cabin to be maintained at pressure as 1 Bar,  $25^{\circ}\text{C}$ ?

10 marks

12. a. What are the limitations of Carnot refrigeration cycle? 4 marks
- b. In an aero plane uses air-refrigeration system, the air at 5 bars and 200°C is bled-off from the main compressor and is cooled in a heat exchanger with the use of ram air. The pressure and temperature of the air leaving the heat exchanger are 4.5 bar and 40°C. The ram air is forced through the heat exchanger by a fan run by expander turbine. The air coming out from the heat exchanger is passed through an expander and then supplied to the cabin at 1 bar, the pressure loss between the expander and cabin is 0.2 bars. If the air flow rate through the expander turbine is 30 kg/min. find the followings- The temperature of the air leaving the expander, The kW delivered to the ram air which is passed through the heat exchanger, The refrigeration capacity in tons of refrigeration if the cold air coming out from the expander turbine is tempered by mixing with bypassed warm air and delivered to the cabin. The temperature of the air leaving the cabin is limited to 25° C. Assume the followings:  
 Isentropic efficiency of the expander turbine = 75%.  
 $\gamma$  (for air) = 1.4,  $C_p$  (for air) = 1KJ/kg-K  
 Neglect heat losses. 10 marks

### MODULE II

13. a. A refrigerating machine using F12 as working fluid works between the temperatures 18°C and 37°C. The enthalpy of liquid at 37°C is 72 KJ/kg. The enthalpies of F12 entering and leaving the compressor are 195 KJ/kg and 227 KJ/kg respectively. The rate of circulation of refrigerant is 2 kg/min and efficiency of compressor is 85% Determine; Capacity of the plant in TONS of refrigeration. Power required running the plant, COP of the plant? 7 marks
- b. Explain Sub cooling by liquid vapour regenerative heat exchanger method of improving COP of vapour compression system with the help of necessary sketch? 7 marks
14. a. A simple vapour compression cycle using Freon 22 is designed for a load of 100 TR. The suction condition of the refrigerant is saturated vapour at 5°C and discharge condition is super heated at 40°C. Calculate (a) The mass flow rate of refrigerant; (b) The COP.? 7 marks
- b. Explain the Multi stage compression (with flash inter cooling) method of improving COP with the help of line diagram and P- h diagram? 7 marks

### MODULE III

15. a. Electrolux vapours absorption system of refrigeration with the help of line diagram? 7 marks
- b. explains Steam jet refrigeration system with the help of line diagram what are the applications, relative merits and demerits? 7 marks

16. a. Explain Lithium Bromide water system. What are the merits and demerits of the system? 8 marks
- b. Compare water absorption system and vapour compression system? What are the relative merits and demerits? 6 marks

#### MODULE IV

17. a. Explain different types of refrigerants available and their relative merits and demerits? 7 marks
- b. Explain the working of Scroll compressor with the help of neat sketch? 7 marks
- 18.a. Explain reciprocating compressor with the help of neat diagram? What are the relative merits and demerits? 7 marks
- b. Explain working of a cooling tower with the help of a neat sketch. What are the applications of cooling tower? 7 marks

#### MODULE V

- 19a. An Auditorium has seating capacity 800 people is to be maintained at 23°C DBT and 50% RH. The outdoor conditions are 40°C DBT and 27°C WBT. The various loads in the office are: Solar heat gain 10KW, sensible heat gain per occupant 80W, Latent heat per occupant 70W, Lighting load 5KW, Sensible heating load from other sources 12KW, Infiltration load 0.3m<sup>3</sup>/sec. Outdoor air and return air is mixed in the ratio of 1: 6, before cooling coil (processing unit) and then supplied to room. The supply temperature cannot be lower than 12°C. Find capacity of the plant required, mass flow rate of air 12 marks
- b. Define absolute humidity and relative humidity? 2 marks
- 20 a. An office for seating 30 occupants is to be maintained at 22°C DBT and 55% RH. The outdoor conditions are 36°C DBT and 27°C WBT. The various loads in the office are: Solar heat gain 8500W, Sensible heat gain per occupant 83W, Latent heat gain per occupant 100W, Lighting load 2500W, Sensible heat load from other sources 12000W, infiltration load 15 cubic meter/minute. Assuming 40% fresh air and 60% of re-circulated air passing through the evaporator coil and ADP of the coil is 8 °C. Find capacity of the plant and mass flow rate of air? 12 marks
- b. What is dew point temperature and represent it in the psychrometric chart? 2 marks

## Syllabus

### Module 1- Introduction to refrigeration

Introduction –applications of refrigeration. Thermodynamics of refrigeration- reversed Carnot cycle, Limitations, heat pump, COP, Unit of refrigeration- Air refrigeration systems- Reversed Joule cycle, Air craft refrigeration systems, comparison, Boot strap system. Numerical examples.

### Module 2 Vapour compression refrigeration.

Vapour compression systems- representation on T- s and P- h Diagrams. COP- Effect of operating parameters on COP – methods of improving COP of simple cycle- super- heating , under cooling, Liquid suction heat exchanger, actual cycle. Multi pressure systems - multi compression and multi evaporator, systems, Inter cooling - flash inter cooling and flash gas removal- numerical examples, Cryogenic temperature system, Cascade system.

### Module 3 Vapour absorption and steam jet refrigeration.

Vapour absorption systems - Ammonia – water system - simple system- drawbacks- Lithium Bromide water system- Electrolux- comparison with vapour compression system. Steam jet refrigeration. Applications, relative merits and demerits.

### Module 4 Refrigeration system components

Refrigeration system components- Compressors, condensers, expansion devices, evaporators. Cooling towers- Different types and their application fields- Refrigerant leakage and detection – charging of refrigerant. Refrigerants and their properties, CFC, HCFC, HFC, HC refrigerants -Eco-friendly Refrigerants, ODP, GWP, selection of refrigerants for different applications

### Module 5 Air conditioning.

Psychrometric, Psychrometric properties- dry, wet and dew point temperature – humidity, specific humidity, absolute humidity, relative humidity and degree of saturation- enthalpy of moisture- adiabatic saturation process -psychrometers. psychrometric chart- Psychrometric processes- adiabatic mixing- sensible heating and cooling- humidifying and dehumidifying, air washer – bypass factor- sensible heat factor-RSHF and GSHF line- Design condition- Apparent dew point temperature – Numerical examples.

Air conditioning- applications, Comfort air conditioning- factors affecting human comfort. Effective temperature – comfort chart. Unitary and central system comparison. Capacity determination-cooling load estimation. COP, EER, IEER, IPLV, star rating, specification of capacity TONs, HP, Numerical examples.

### Text Books

1. Refrigeration and Air Conditioning, Arora C.P, Tata McGraw hill.
2. A Course in Refrigeration and air conditioning Arora S. C. and S. Domkundwar, Dhanpat Rai and Company. 2002
3. A text book of Refrigeration and air conditioning – R.K .Regiput, Katson books.
4. Refrigeration and air conditioning - Ahamadul Ameen Eastern economy addition.
5. Heating, Ventilating, and Air Conditioning: Analysis and Design, Faye C. Mcquiston, Jerald D. Parker, Jeffrey D. Spitler, John Wiley and sons. New York

### Data books

1. Refrigeration tables and charts including air conditioning data, C P Kothandaraman , New Age International.
2. Refrigeration and air conditioning data book, Domkunduwar and Domkundwar, Dhanpat Rai & co.

### Reference books

1. ASHRAE Handbook 201(Volume 1,2,3)
2. Principles of heating ventilation and air conditioning in building, john Dixon, Delmar learning
3. Analysis and design of heating ventilation and air conditioning system, Herbert W stanferd and Adam F spach, CRC press -Taylor and Francis.

### Course Contents and Lecture Schedule

MODULE	TOPICS	HOURS ALLOTTED
1	Introduction –applications of refrigeration.	2-0-0
	Thermodynamics of refrigeration- reversed Carnot cycle, Limitations, heat pump, COP ,Unit of refrigeration- Air refrigeration systems- Reversed Joule cycle, Air craft refrigeration systems, comparison.	2-1-0
	Boot strap system. Numerical examples	2-1-0
2	Vapour compression systems- representation on T- s and P- h Diagrams. COP- Effect of operating parameters on COP	2-1-0
	methods of improving COP of simple cycle- super- heating , under cooling, Liquid suction heat exchanger, actual cycle.Multi pressure systems - multi compression and multi evaporator, systems, Inter cooling - flash inter cooling and flash gas removal-	2-1-0



	numerical examples .	
	Cryogenic temperature system, Cascade system.	2-0-0
3	Vapour absorption systems - Steam jet refrigeration. Applications, relative merits and demerits - simple system- drawbacks-Lithium Bromide water system.	3-1-0
	Electrolux- comparison with vapour compression system.	1-0-0
	Steam jet refrigeration. Applications, relative merits and demerits	1-0-0
4	Refrigeration system components- Compressors, condensers, expansion devices, evaporators.	2-1-0
	Cooling towers- Different types and their application fields- Refrigerant leakage and detection – charging of refrigerant.	2-0-0
	Refrigerants and their properties, CFC, HCFC, HFC, HC refrigerants -Eco-friendly Refrigerants, ODP, GWP, selection of refrigerants for different applications.	2-0-0
5	Psychrometric, Psychrometric properties- dry, wet and dew point temperature – humidity, specific humidity, absolute humidity, relative humidity and degree of saturation- enthalpy of moisture-adiabatic saturation process -psychrometers. psychrometric chart- Psychrometric processes- adiabatic mixing- sensible heating and cooling- humidifying and dehumidifying, air washer – bypass factor- sensible heat factor-RSHF and GSHF line- Design condition- Apparent dew point temperature – Numerical examples.	3-1-0
	Air conditioning- applications, Comfort air conditioning- factors affecting human comfort. Effective temperature – comfort chart. Unitary and central system comparison. Capacity determination- cooling load estimation. COP, EER, IEER, IPLV, star rating, specification of capacity TONs, HP, Numerical examples.	3-1-0

---

SEMESTER VII

---

OPEN ELECTIVE

---

COURSE CODE	COURSE NAME	CATEGORY	L	T	P	CREDITS
22MEO703.1	INTRODUCTION TO BUSINESS ANALYTICS	O	2	1	0	3

Prerequisite: Basic knowledge of information systems, statistics, and business environment

Course Outcomes: After the completion of the course the student will be able to

CO 1	Understand the fundamentals of business intelligence, analytics, and data science.
CO 2	Use real life data for effective decision making using statistical models.
CO 3	Understand the basic concepts of data warehousing and use of data mining techniques for business analytics.
CO 4	Describe text analytics and understand the need for text mining.
CO 5	Understand the essence of business performance management and business reporting.
CO 6	Explore emerging technologies, legal and ethical issues that may impact analytics and business intelligence.

Mapping of course outcomes with program outcomes

	PO 1	PO 2	PO 3	PO 4	PO 5	PO 6	PO 7	PO 8	PO 9	PO 10	PO 11	PO 12
CO 1	2	1	-	-	-	-	-	-	-	-	-	-
CO 2	2	2	1	3	2	-	-	-	-	-	-	-
CO 3	-	2	3	1	3	-	-	-	-	-	-	-
CO 4	-	-	2	2	2	1	-	-	-	-	-	-
CO 5	-	-	-	2	-	2	-	-	1	3	2	-
CO 6	-	-	-	-	-	1	-	2	-	-	-	1

Assessment Pattern

Bloom's Category	Continuous Assessment Tests		End Semester Examination
	1	2	
Remember	20	20	20
Understand	20	20	50
Apply	10	10	20
Analyse	-	-	10
Evaluate	-	-	-
Create	-	-	-

## Mark distribution

Total Marks	CIE	ESE	ESE Duration
150	50	100	3 hours

### Continuous Internal Evaluation Pattern:

Attendance	: 10 marks
Continuous Assessment Test (2 numbers)	: 25 marks
Assignment/Quiz/Course project	: 15 marks

End Semester Examination Pattern: There will be two parts; Part A and Part B. Part A contain 10 questions with 2 questions from each module, having 3 marks for each question. Students should answer all questions. Part B contains 2 questions from each module of which student should answer any one. Each question can have maximum 2 sub-divisions and carry 14 marks.

### Course Level Assessment Questions:

#### CO 1 Understand the fundamentals of business intelligence, analytics and data science

1. Differentiate between predictive analytics and prescriptive analytics.
2. What is online transaction processing system?
3. List and describe the major components of Business Intelligence.

#### CO 2 Use real life data for effective decision making using statistical models

1. What are the various measures of dispersion?
2. Write a short note on time series forecasting.
3. What is data pre-processing? Why is it required?

#### CO 3 Understand the basic concepts of data warehousing and use of data mining techniques for business analytics

1. What is a data warehouse?
2. Identify five specific applications of data mining and a few common characteristics.
3. List five software tools used for data mining applications.

#### CO 4 Describe text analytics and understand the need for text mining

1. Why is the popularity of text mining as an analytics tool increasing?
2. Explain the importance of text mining in academia.
3. What is web mining? List the applications of web mining

CO 5 Understand the essence of business performance management and business reporting

1. What are the various functions an effective business report fulfils?
2. What is a performance measurement system? How does it work?
3. Explain the role of business analytics in human resource management.

CO 6 Explore emerging technologies, legal and ethical issues that may impact analytics and business intelligence.

1. How does cloud computing affect Business Intelligence?
2. How does traditional analytics make use of location-based data?
3. List a few legal issues of analytics.

Model Question Paper

APJ ABDUL KALAM TECHNOLOGICAL UNIVERSITY  
SEVENTH SEMESTER B.TECH DEGREE EXAMINATION  
MET415: INTRODUCTION TO BUSINESS ANALYTICS

Time:

3hours

Maximum marks: 100

PART-A (Answer all Questions)

- 1 Define Business Intelligence. How will you relate it with Business Analytics?
- 2 What do you understand by the term Big Data?
- 3 What are the measures of central tendency?
- 4 Under what circumstances the use of inter-quartile range becomes essential?
- 5 How does a data warehouse differ from a transactional database?
- 6 Distinguish between text mining and web mining?
- 7 What are the distinguishing features of Key Performance Indicators?
- 8 What are the three components of a Business Performance System?
- 9 There are serious privacy concerns in analytics. Comment.
- 10 Name at least three major cloud service providers. (3x10=30)

PART-B

- 11 Detail at least seven key system-oriented trends that have fostered the growth of Business Intelligence based decision making. 14
- OR
- 12 Explain the various levels of analytics 14
- 13 a What are the characteristics that define the readiness level of data for an analytic study? 9
- b Differentiate between structured and unstructured data. 5
- OR
- 14 What is logistic regression? With a suitable example, explain the steps involved. 14
- 15 a What are the important steps in data mining? 9
- What are data lakes? Compare it with a data warehouse. 5
- OR
- 16 a Write a short note on sentiment analysis 6
- b What is social media analytics? Explain its significance in business. 8
- 17 a What are the main differences among line, bar and pi charts? When should you use one over the others? 7
- b What is an information dashboards? Why are they so popular? 7

OR

- 18 List and briefly describe the four phases of Business Performance Management Cycle 1  
4
- 19 What are the major issues managers have to keep in mind while exploring IoT? 7  
What are the potential benefits of using geo-spatial data for analytics? Give 7  
examples.
- OR
- 20 List a few ethical issues in analytics. 7  
Describe new organisational units that are created because of analytics 7

## Syllabus

Module 1 (6 Hours)	<p>Introduction to Business Intelligence- Definition, Need, and Evolution of Business Intelligence System and its components.</p> <p>Introduction to Business Analytics- Definition- Levels of Analytics – Descriptive, Predictive and Prescriptive Analytics- Application of business analytics in industries- case studies.</p> <p>Transaction Processing and Analytic Processing- Fundamentals of OLAP and OLTP</p> <p>Introduction to Big Data Analytics- Characteristics- Sources of Big Data.</p>
Module 2 (10 Hours)	<p>Data- Definition- Sources of Data- Readiness Level of Data for Analytic study- Unstructured and structured data- classification of data- Data pre-processing- Steps in data pre-processing.</p> <p>Statistical Modelling for Business Analytics- Descriptive Statistics- Measures of Central Tendency and Dispersion- Quartiles and inter-quartile range.</p> <p>Regression Modelling for Inferential Statistics- Linear Regression, Logistic Regression and Time Series Forecasting.</p>
Module 3 (8 Hours)	<p>Data Warehousing: Characteristics- Design Considerations for data warehouse- Data warehousing process- Data Lakes.</p> <p>Data Mining: Concepts - Data mining process- Applications- Software Tools.</p> <p>Text and Web Analytics: Text analytics and text mining overview - Text mining applications - Sentiment Analysis- Web mining overview- Fundamentals of Social media analytics</p>
Module 4 (6 Hours)	<p>Business Reporting- Concepts- Different types of charts and graphs- Data Visualisation and Visual Analytics</p> <p>Business Performance Management: Business performance management cycle- Performance Measurement System- Key Performance Indicators</p> <p>Analytics in Business Support Functions- Sales &amp; Marketing, Human Resources, Financial Analytics, Production and operations analytics</p>
Module 5 (5 Hours)	<p>Recent Trends, Privacy and Managerial Considerations in Analytics: Use of Internet of Things for Business Analytics - Cloud Computing and Business Analytics- Location Based Analytics for Organisations - Issues of Legality, Privacy and Ethics- Impacts of Analytics in Organisations</p>

### Text Book

1.R. Sharda, D. Delen, and E. Turban, “Business Intelligence, Analytics, and Data Science: A Managerial Perspective”, Pearson, 4<sup>th</sup> edition, 2018.

### Reference Books

- 1.R. N. Prasad and S. Acharya, “Fundamentals of Business Analytics”, Wiley, 2<sup>nd</sup> Edition, 2016
- 2.J. R. Evans, “Business Analytics”, Pearson, 3<sup>rd</sup> Edition, 2019.
3. A. Maheshwari, “Data Analytics”, McGraw Hill Education, 1<sup>st</sup> Edition, 2017



4. Business Analytics for Managers: Taking Business Intelligence Beyond Reporting, 2nd Edition, Wiley, 2016

Course Contents and Lecture Schedule

No	Topic	Hours
<b>Module 1 (6 Hours)</b>		
1.1	Introduction to Business Intelligence- Definition, Need, and Evolution of Business Intelligence System and its components	1
1.2	Introduction to Business Analytics- Definition- Levels of Analytics	1
1.3	Descriptive, Predictive and Prescriptive Analytics	1
1.4	Application of business analytics in industries- case studies	1
1.5	Transaction Processing and Analytic Processing- Fundamentals of OLAP and OLTP	1
1.6	Introduction to Big Data Analytics- Characteristics- Sources of Big Data	1
<b>Module II (10 Hours)</b>		
2.1	Data- Definition- Sources of Data- Readiness Level- Unstructured and structured data	1
2.2	Classification of data- Data Pre-processing- Steps in data pre-processing	1
2.3	Statistical Modelling for Business Analytics- Descriptive Statistics- Measures of Central Tendency and Dispersion	2
2.4	Quartiles and inter-quartile range.	1
2.5	Regression Modelling for Inferential Statistics- Linear Regression.	2
2.6	Logistic Regression	2
2.7	Time Series Forecasting	1
<b>Module III (8 Hours)</b>		
3.1	Data Warehousing: Characteristics- Design Considerations for data warehouse- Data warehousing process- Data Lakes	2
3.2	Data Mining: Concepts - Data mining process	1
3.3	Applications of Data Mining	1
3.4	Software Tools	1
3.5	Text & Web Analytics: Text analytics and text mining overview	1
3.6	Text mining applications- Sentiment Analysis	1
3.7	Web mining overview- Fundamentals of Social media analytics	1
<b>Module IV (6 Hours)</b>		
4.1	Business Reporting- Concepts- Different types of charts and graphs-	1
4.2	Data Visualisation and Visual Analytics	1
4.3	Business Performance Management: Business performance management cycle-	1
4.4	Performance Measurement System- Key Performance Indicators	1

4.5	Analytics in Business Support Functions- Sales & Marketing, Human Resources, Financial Analytics, Production and operations analytics	2
Module V (5 Hours)		
5.1	Use of Internet of Things for Business Analytics - Cloud Computing and Business Analytics	2
5.2	Location Based Analytics for Organisations	1
5.3	Issues of Legality, Privacy and Ethics	1
5.4	Impacts of Analytics in Organisations	1

COURSE CODE	COURSE NAME	CATEGORY	L	T	P	CREDITS
22ME0703.2	QUANTITATIVE TECHNIQUES FOR ENGINEERS	O	2	1	0	3

Preamble: This course is designed to facilitate the students to acquire knowledge about quantitative techniques for engineers. This course covers linear programming, transportation problem, assignment problem, sequencing problem, network analysis, decision theory, game theory, queuing theory and simulation. It empowers the students to amalgamate their knowledge and thus inculcate the skills needed to apply these techniques in industry.

Prerequisite: Nil

Course Outcomes: After the completion of the course the student will be able to

CO 1	Solve problems using linear programming methods.
CO 2	Solve transportation problems and assignment problems.
CO 3	Solve sequencing problems and perform network analysis.
CO 4	Apply decision theory and game theory.
CO 5	Apply queuing theory and perform simulation for queuing problems.

Mapping of Course Outcomes with Program Outcomes

	PO 1	PO 2	PO 3	PO 4	PO 5	PO 6	PO 7	PO 8	PO 9	PO 10	PO 11	PO 12
CO 1	3	3	2	1	2					1	2	2
CO 2	3	3	2	1	2					1	2	2
CO 3	3	3	2	1	2					1	3	2
CO 4	3	3	2	1	2					1	2	2
CO 5	3	3	2	1	2					1	2	2

Assessment Pattern

Bloom's Category	Continuous Assessment Tests		End Semester Examination
	1	2	
Remember	10	10	10
Understand	10	10	20
Apply	30	30	70
Analyse			
Evaluate			
Create			

Mark Distribution

Total Marks	CIE	ESE	ESE Duration
150	50	100	3 hours

**Continuous Internal Evaluation Pattern:**

Attendance	: 10 marks
Continuous Assessment Test (2 numbers)	: 25 marks
Assignment/Quiz/Course Project	: 15 marks

End Semester Examination Pattern: There will be two parts; Part A and Part B. Part A contain 10 questions with 2 questions from each module, having 3 marks for each question. Students should answer all questions. Part B contains 2 questions from each module of which student should answer any one. Each question can have maximum 2 sub-divisions and carry 14 marks.

**Course Level Assessment Questions**

**Course Outcome 1 (CO1):**

1. Demonstrate the applications of quantitative techniques.
2. Formulate mathematical model for the given problem.
3. Apply linear programming methods to get the optimum solution.

**Course Outcome 2 (CO2):**

1. Identify the applications of transportation problems and assignment problems.
2. Solve transportation problem to get the initial feasible solution or optimum solution.
3. Solve assignment problem in order to minimize the total cost.

**Course Outcome 3 (CO3):**

1. Demonstrate assumptions of sequencing problems.
2. Determine the optimal sequence of operations.
3. Construct project network diagram and perform network analysis.

**Course Outcome 4 (CO4):**

1. Compare various decision making conditions.
2. Determine the optimal decision based on the given criterion.
3. Determine the optimal strategies and value of the game.

**Course Outcome 5 (CO5):**

1. Illustrate the concept of simulation.
2. Demonstrate Monte Carlo simulation for a queuing system.
3. Determine the parameters of the queuing system.

Model Question Paper

SEVENTH SEMESTER B. TECH DEGREE EXAMINATION

Course Code: MET425

Course Name: QUANTITATIVE TECHNIQUES FOR ENGINEERS

Max. Marks: 100

Duration: 3

Hours

PART A

(ANSWER ALL QUESTIONS, EACH QUESTION CARRIES 3 MARKS)

1. Discuss the applications of quantitative techniques.
2. Explain alternate optimum solution, unbounded solution and infeasible solution.
3. What are the applications of transportation problem?
4. Explain the similarity between transportation problem and assignment problem.
5. What are the assumptions in sequencing problem?
6. What is crashing of project network?
7. Differentiate between decision under certainty and decision under risk.
8. Explain players, strategy and saddle point of game theory.
9. Define simulation and its advantages.
10. Discuss the steps of Monte Carlo simulation.

PART B

(ANSWER ONE FULL QUESTION FROM EACH MODULE, EACH QUESTION CARRIES 14 MARKS)

MODULE 1

11. Solve the following LP problem using simplex method.

$$\text{Maximize } Z = 3X_1 + 5X_2$$

Subject to

$$X_1 + X_2 \leq 4$$

$$3X_1 + 2X_2 \leq 18$$

$$X_1 \text{ and } X_2 \geq 0$$

12. A company produces 2 types of hats A and B. Every hat A requires twice as much labour time as the second hat B. If the company produces only hat B then it can produce a total of 500 hats per day. The market limits daily sales of hat A and B to 150 and 250 respectively. The profit on hat A and B are Rs. 8 and Rs. 5 respectively. Solve graphically to get the optimum solution.

MODULE 2

13. Obtain the initial basic feasible solution for the following transportation problem using (a) North west corner rule (b) Least cost cell method (c) Vogel's approximation method

	Warehouses				
Plants		X	Y	Z	Supply
	A		8	7	3

	B	3	8	9	70
	C	11	3	5	80
	Demand	50	80	80	

State which of the methods is better

14. Solve the following assignment problem in order to minimize the total cost. The costs of doing different jobs by different operators are given below.

Job	Operator				
	1	2	3	4	5
1	5	6	8	6	4
2	4	8	7	7	5
3	7	7	4	5	4
4	6	5	6	7	5
5	4	7	8	6	8

### MODULE 3

15. Find an optimal sequence for processing five jobs through four machines in the order A-B-C-D-E. Find the total minimum elapsed time if no passing of jobs is permitted. Also find idle time on each machine.

Jobs	Machines				
	A	B	C	D	E
1	9	7	5	4	11
2	8	8	6	7	12
3	7	6	7	8	10
4	10	5	5	4	8

16. Consider the data of a project summarized in the following table.

Activity	Immediate Predecessor(s)	Duration (weeks)		
		a	m	b
A	-	3	5	8
B	-	6	7	9
C	A	4	5	9
D	B	3	5	8
E	A	4	6	9
F	C, D	5	8	11
G	C, D, E	3	6	9
H	F	1	2	9

- Construct the project network
- Find the expected duration and variance of each activity
- Find the critical path and expected project completion time.
- What is the probability of completing the project on or before 35 weeks?

MODULE 4

17. Consider the following cost matrix and determine the best order size using the minimax criterion.

		Demand ( $D_j$ )				
		50	100	150	200	250
Order Size ( $Q_i$ )	75	950	1200	575	-675	-1425
	150	50	1700	2000	2250	1600
	225	-850	850	2550	3550	4525
	300	-1800	600	1800	2000	5000

Also obtain best order size based on the Hurwicz criterion ( $\alpha = 0.5$ ).

18. Solve the following pay-off matrix. Also determine the optimal strategies and value of the game.

		A	
		1	2
B	1	10	8
	2	6	12

MODULE 5

19. A weighing station has single weighing bridge. The arrival rate of the vehicles coming to the weighing station follows Poisson distribution and it is 45 vehicles per hour. The service rate also follows Poisson distribution and it is 55 vehicles per hour. In front of the weighing bridge, the waiting space is sufficient for a maximum of 10 vehicles. Find the following;

- Average waiting number of vehicles in the queue in front of the weighing bridge as well as in the weighing station.
- Average waiting time per vehicle in front of the weighing bridge as well as in the weighing station.

20. The arrival rate of customers at a banking counter follows Poisson distribution with a mean of 30 per hour. The service rate of the counter clerk also follows Poisson distribution with a mean of 45 per hour.

- What is the probability of having 0 customer in the system?
- What is the probability of having 12 customers in the system?
- Find  $L_s$ ,  $L_q$ ,  $W_s$  and  $W_q$ .

## Syllabus

### Module 1

Introduction to quantitative techniques – basics of operations research – applications. Linear programming – problem formulation – graphical method – simplex method – big-m method – two-phase method – duality in linear programming. (7 hours)

### Module 2

Transportation problem – formulation – balanced & unbalanced transportation problems – north west corner rule – least cost method – Vogel's approximation method – stepping stone method. Assignment problem – formulation – optimal solution – Hungarian algorithm – variants of assignment problems. (7 hours)

### Module 3

Sequencing problem – terminology and notations – assumptions – problems with n jobs through two machines – problems with n jobs through three machines – problems with n jobs through m machines. Network analysis – basic terms – network construction – time analysis – critical path method (CPM) – programme evaluation and review technique (PERT) – cost considerations in network analysis – crashing. (7 hours)

### Module 4

Decision theory – steps in decision theory approach – decision making conditions – decisions under conditions of risk – decisions under uncertainty conditions – decision tree analysis. Game theory – games with saddle points – games without saddle points – 2 x 2 games – graphical method for m x 2 & 2 x n games. (7 hours)

### Module 5

Introduction to queuing theory – terminologies – classification of queuing models – single server problems – multi server problems. Simulation – generation of random numbers – Monte Carlo simulation – queuing simulation model. (7 hours)

### Text Books

1. Paneerselvam, R., Operations Research, Prentice Hall of India, New Delhi, 2017.
2. Taha, H. A., Operations Research: An Introduction, Pearson, 2013.

### Reference Books

1. Miller, D. M. and Schmidt, J. W., Industrial Engineering and Operations Research, John Wiley & Sons, Signapore, 1990.
2. Goel, B. S. and Mittal, S. K., Operations Research, Pragati Prakashan, Meerut, 1999.
3. Banks, J., Carson, J. S., Nelson, B. L., and Nicol, D. M., Discrete-Event System Simulation, Third Edition, Pearson Education, Inc., 2001.



Course Contents and Lecture Schedule

No	Topic	No. of Lectures
1	Module 1	
1.1	Introduction to quantitative techniques – basics of operations research – applications.	1
1.2	Linear programming – problem formulation – graphical method.	2
1.3	simplex method – big-m method – two-phase method – duality in linear programming.	4
2	Module 2	
2.1	Transportation problem – formulation – balanced & unbalanced transportation problems – north west corner rule – least cost method	2
2.2	Vogel’s method – stepping stone method.	2
2.3	Assignment problem – formulation – optimal solution – Hungarian algorithm – variants of assignment problems.	3
3	Module 3	
3.1	Sequencing problem – terminology and notations – assumptions – problems with n jobs through two machines – problems with n jobs through three machines – problems with n jobs through m machines.	2
3.2	Network analysis – basic terms – network construction – time analysis – critical path method (CPM).	2
3.3	Programme evaluation and review technique (PERT) – cost considerations in network analysis – crashing.	3
4	Module 4	
4.1	Decision theory – steps in decision theory approach – decision making conditions – decisions under conditions of risk.	2
4.2	Decisions under uncertainty conditions – decision tree analysis.	2
4.3	Game theory – games with saddle points – games without saddle points – 2 x 2 games – graphical method for m x 2 & 2 x n games.	3
5	Module 5	
5.1	Introduction to queuing theory – terminologies – classification of queuing models – single server problems.	3
5.2	Multi server problems.	3
5.3	Simulation – generation of random numbers – Monte Carlo simulation – queuing simulation model.	2

COURSE CODE	COURSE NAME	CATEGORY	L	T	P	CREDITS
22MEO703.3	AUTOMOTIVE TECHNOLOGY	O	2	1	0	3

Preamble: The objective of this course is

- To know the anatomy of automobile in general
- To understand the working of different automotive systems and subsystems
- To update the latest developments in automobiles

Prerequisite: EST 120 Basics of Mechanical Engineering

Course Outcomes: After the completion of the course the student will be able to

CO 1	Explain different automotive systems and subsystems .
CO 2	Illustrate the working of transmission, suspension, steering and braking systems of an automobile.
CO 3	Summarize the basic technology in electric vehicles.
CO 4	Explain the various safety, security and comfort systems in automotive technology.

Mapping of course outcomes with program outcomes

	PO 1	PO 2	PO 3	PO 4	PO 5	PO 6	PO 7	PO 8	PO 9	PO 10	PO 11	PO 12
CO 1	✓											✓
CO 2	✓											✓
CO 3	✓											✓
CO 4	✓											✓

Assessment Pattern

Bloom's Category	Continuous Assessment Tests		End Semester Examination
	1	2	
Remember			
Understand	50	50	100
Apply			
Analyse			
Evaluate			
Create			

### Mark distribution

Total Marks	CIE	ESE	ESE Duration
150	50	100	3 hours

#### Continuous Internal Evaluation Pattern:

Attendance	: 10 marks
Continuous Assessment Test (2 numbers)	: 25 marks
Assignment/Quiz/Course project	: 15 marks

End Semester Examination Pattern: There will be two parts; Part A and Part B. Part A contain 10 questions with 2 questions from each module, having 3 marks for each question. Students should answer all questions. Part B contains 2 questions from each module of which student should answer any one. Each question can have maximum 2 sub-divisions and carry 14 marks.

#### Course Level Assessment Questions

##### Course Outcome 1 (CO1):

1. Explain the injection system in an SI engine.
2. Differentiate between MPFI and CRDI.
3. Describe an automobile engine layout and its components.

##### Course Outcome 2 (CO2)

1. Explain Ackermann steering mechanism with a neat sketch.
2. Explain in detail the working and function of ABS braking system.
3. Describe the need of clutch and gearbox in an automobile?

##### Course Outcome 3 (CO3):

1. What is the difference between an electric vehicle and a hybrid vehicle?
2. List out the differences in the chassis design of an electric vehicle comparing with the conventional chassis.
3. Explain the basic operation of a fuel cell.

##### Course Outcome 4 (CO4):

1. Explain the various safety features employed in automotive technology?
2. Explain the air conditioning system in an automobile.
3. Describe the functions of electro-mechanical and electronic immobilizers in the security of an automobile?

Model Question Paper

Max. Marks: 100

Duration: 3 Hours

PART A (30 marks)

*Answer all questions, each carries 3 marks.*

1. Explain turbocharger lag and the methods to reduce it.
2. Identify the difference between SI and CI engine.
3. Describe automated manual transmission.
4. Explain the principle of dry friction clutch.
5. Compare between drum and disc brakes.
6. Summarize the features of hydro pneumatic suspension system .
7. Indicate the advantage of EV over conventional IC engines.
8. Explain Ackermann principle in steering mechanism system.
9. Explain the working of remote keyless entry in a vehicle.
10. Describe the child lock safety system.

PART B (70 marks)

*Answer any one question from each module, each carries 14 marks.*

*Module 1*

11. a) Distinguish between MPFI and CRDI systems. (6)
- b) Explain the working and advantages of turbocharger with a neat sketch (8)
12. Explain the fuel supply system, injection system and ignition system in an SI engine. (14)

*Module 2*

13. a) Discuss the working of Pull type diaphragm clutch with a neat sketch. (8)
- b) Cite the principle of operation of an electromagnetic clutch . (6)

14. a) Explain the need of a gear box and the common troubles encountered in gear boxes along with suitable remedies . (8)
- b) Describe the working of an epicyclic gear box. (6)

*Module 3*

15. a) Represent the features of McPherson strut suspension system with a neat sketch. (8)
- b) Explain the function of an antiroll bar in a four wheeled vehicle . (6)
16. a) Discuss the working and advantages of ABS over conventional systems. (8)
- b) Explain the properties of friction lining and pad materials (6)

*Module 4*

17. a) Differentiate between over steering and under steering. (8)
- b) Illustrate the rack and pinion steering gear box system. (6)
18. a) Explain the basic principle of a hydrogen fuel cell and its efficiency. (8)
- b) Indicate different type of batteries used in an electric vehicle. (6)

*Module 5*

19. a) Explain the air conditioning system in an automobile. (8)
- b) Discuss the methods to control the aerodynamic lift in vehicles. (6)
20. a) Classify active and passive safety systems in a car. (8)
- b) Explain how an electronic immobilizer can prevent the vehicle theft. (6)

## Syllabus

### Module 1 (7 hours)

Automobile system layout- Engine and its components, SI and CI engine, working principle, Fuel supply and injection system-comparison, multiport fuel injection (MPFI) and common rail direct injection (CRDI) systems. Ignition system, Engine emission and standards.

Super charging systems: fundamentals, naturally aspirated engines and supercharged engines– Turbo charger, turbo lag

### Module 2 (7 hours)

Friction clutch: Principle, dry friction clutches- Pull type diaphragm clutch, multiple diaphragm clutch, multi-plate hydraulically operated automatic transmission clutch, semi centrifugal clutch, fully automatic centrifugal clutch, and integral single plate diaphragm clutch. Electromagnetic clutch operation. wet clutch, clutch friction materials, fluid friction coupling.

Manual transmission- Need of gear box, power to weight ratio, speed operating range-five speed and reverse sliding mesh, constant mesh, and synchromesh gear boxes. Automatic transmission- Epicyclic gear box - torque convertor – Over drives. Automated manual transmission.

### Module 3 (7 hours)

Suspension system: - Types of suspension springs, suspension geometry and terminology, types of suspension systems, independent suspension, Antiroll bar, Hydrogen suspension, hydro pneumatic suspension, suspension roll center and body roll.

Brakes: Principle of brake, classification of brakes-mechanical and hydraulic brakes- Drum and Disc brakes, properties of friction lining and pad materials, Anti-Lock Braking system (ABS), principle of operation and types of ABS.

### Module 4 (7 hours)

Steering: -basic principle of a steering system– Ackermann –over steer and under steer – Steering geometry -slip angle, camber, king pin inclination, caster, toe-in and toe-out. Steering gear box–types- need of power assisted steering.

Electric Vehicle Technology (EVT): EV Architecture, types of batteries, battery parameters, super capacitors. Fuel cells and its efficiency. EV Chassis – requirements, suspension for EVs. Recent Electric vehicles- Electric mobility aids. Future of electric vehicles –Tesla S, Maglev trains, Electric rail road systems.

### Module 5 (7 hours)

Safety-Active and passive safety, air bags, seat belt tightening system, forward collision warning system, child lock, advanced safety systems.

Comfort system –Automotive air-conditioning, aerodynamics lift and drag reduction, adaptive cruise control, tilt-able steering column and power window and advanced comfort system.

Security system -Anti theft technology-mechanical, electromechanical and electronic immobilizers, alarm system and remote keyless entry.

#### Text Books

1. Heinz Heisler, Vehicle and engine technology, Butterworth-Heinemann, 2<sup>nd</sup> edition,1998.
2. R.B. Gupta., Auto design , Satya Prakashan Publishers, New Delhi, 2016 .
3. James Larminie and John Lowry, Electric vehicle technology explained, Wiley publications, 2<sup>nd</sup> edition, 2015.
4. Kirpal Singh, Automobile Engineering Vol.1 & Vol.2, Standard Publishers, 13<sup>th</sup> edition, 2020.

#### Reference Books

- 1.V.A.W. Hillier, Fundamentals of modern vehicle technology, Butterworth-Heinemann, 2nd edition,1998.
- 2.Tom Denton, Electric and Hybrid Vehicles, Routledge Publishers, 2nd edition, 2020.
- 3.Ljubo Vlacic, Michel Parent and Fumio Harashima, Intelligent vehicle technologies, Butterworth-Heinemann publications, Oxford 2001.
- 4.ShimoKim and Rakesh Shresta, Automotive Cyber Security: Introduction Challenges and Standardization, Springer, Singapore, 1st edition. 2020.

#### Course Contents and Lecture Schedule

No	Topic	No. of Lectures
1	Automobile system layout	
1.1	Engine and its components- IC engines, piston, rings, pin, flywheel, connecting rod.	1
1.2	SI and CI engine, working principle	1
1.3	Fuel supply and injection system-comparison	1
1.4	MPFI and CRDI systems	1
1.5	Ignition system	1
1.6	Engine emission and standards	1
1.7	Super charging systems	1
2	Clutch and transmission	
2.1	Principle of dry friction clutches- Single plate clutch, Multi plate hydraulically operated automatic transmission clutch.	1
2.2	Semi centrifugal clutch, fully automatic centrifugal clutch	1
2.3	Integral single plate diaphragm clutch, Electromagnetic clutch	1

	operation.	
2.4	Clutch friction materials, wet clutches, fluid friction coupling.	1
2.5	Need of gear box, power to weight ratio, speed operating range .Sliding mesh, constant mesh and synchromesh gear boxes.	1
2.6	Epicyclic gear box, Torque convertor	1
2.7	Over drives, Automated manual transmission.	1
3	Suspension and brake	
3.1	Suspension system: - Types of suspension springs, suspension geometry and terminology.	1
3.2	Types of suspension systems ,independent suspension.	1
3.3	Antiroll bar, Hydrogen suspension, hydro pneumatic suspension.	1
3.4	Suspension roll center and body roll.	1
3.5	Brakes: Principle of brake, classification of brakes, mechanical and hydraulic brakes.	1
3.6	Drum and Disc brakes, properties of friction lining and pad materials	1
3.7	Anti-Lock Braking system (ABS), principle of operation and types of ABS.	1
4	Steering and Electric vehicle technology	
4.1	Ackermann steering mechanism, over steer and under steer .	1
4.2	Steering geometry -slip angle, camber, king pin inclination, caster, toe-in and toe-out.	1
4.3	Steering gear box, Types of steering gear box, need of power assisted steering.	1
4.4	EV Architecture, types of batteries, battery parameters, super capacitors. Fuel cells and its efficiency.	1
4.5	Super capacitors. Fuel cells and its efficiency.	1
4.6	EV Chassis – requirements, suspension for EVs. Recent Electric vehicles- Electric mobility aids.	1
4.7	Future of electric vehicles –Tesla S, Maglev trains, Electric rail road systems.	1



5	Safety, control and security in automotive technology	
5.1	Safety-Active and passive safety, air bags, seat belt tightening system,	1
5.2	Forward collision warning system, child lock antilock braking system	1
5.3	Comfort system - Automotive air-conditioning, aerodynamics lift and drag reduction,	1
5.4	Adaptive cruise control, tilt-able steering column, power window and advanced comfort system	2
5.5	Anti-theft technology-mechanical, electromechanical and electronic immobilizers.	1
5.6	Alarm system and remote keyless entry.	1

COURSE CODE	COURSE NAME	CATEGORY	L	T	P	CREDITS
22MEO703.4	RENEWABLE ENERGY ENGINEERING	O	2	1	0	3

Preamble: The course is intended to give knowledge of various renewable energy sources, systems and applications and the need in the present context. Students will be able to compare different renewable energy techniques and choose the most appropriate based on local conditions. To equip students in working with projects and to take up research work in connected areas.

Prerequisite: Nil

Course Outcomes: After completion of the course the student will be able to

CO1	Explain renewable energy sources and evaluate the implication of renewable energy. To predict solar radiation at a location
CO2	Explain solar energy collectors, storages, solar cell characteristics and applications
CO3	Explain the different types of wind power machines and control strategies of wind turbines
CO4	Explain the ocean energy and conversion devices and different Geothermal sources
CO5	Explain biomass energy conversion devices. Calculate the Net Present value and payback period

Mapping of course outcomes with program outcomes

	PO 1	PO 2	PO 3	PO 4	PO 5	PO 6	PO 7	PO 8	PO 9	PO 10	PO 11	PO 12
CO 1	3											3
CO 2	3	3			1	1	1				1	3
CO 3	3	3			1	1	1				1	3
CO 4	3	3			1	1	1				1	3
CO 5	3	3			1	1	1				1	3

Assessment Pattern

Bloom's Category	Continuous Assessment Tests		End Semester Examination
	1	2	
Remember	10	10	10
Understand	20	20	20
Apply	20	20	70
Analyse			
Evaluate			
Create			

### Mark distribution

Total Marks	CIE	ESE	ESE Duration
150	50	100	3 hours

### Continuous Internal Evaluation Pattern:

Attendance	: 10 marks
Continuous Assessment Test (2 numbers)	: 25 marks
Assignment/Quiz/Course project	: 15 marks

End Semester Examination Pattern: There will be two parts; Part A and Part B. Part A contain 10 questions with 2 questions from each module, having 3 marks for each question. Students should answer all questions. Part B contains 2 questions from each module of which student should answer any one. Each question can have maximum 2 sub-divisions and carry 14 marks.

### Course Level Assessment Questions:

#### Course Outcome 1 (CO1):

1. What are the main renewable energy sources? Advantages and limitations
2. What is energy efficiency? How is it different from renewable energy use?
3. Define terms : Angle of Incidence, Declination, Solar constant

#### Course Outcome 2 (CO2):

1. Discuss different types of solar collectors
2. Discuss about different types of thermal storage devices
3. Draw the I-V characteristics of Solar cell under varying temperature and irradiation level

#### Course Outcome 3 (CO3):

1. Types of wind turbine and components
2. Difference between wind mill and wind turbine
3. Explain importance of drag and lift force in wind power generation.

#### Course Outcome 4 (CO4):

1. Explain with neat sketch the working of hybrid OTEC system
2. Explain with neat sketch the vapour dominated geothermal system

#### Course Outcome 5 (CO5):

1. Distinguish between Fixed dome plant and floating dome type biomass plant.
2. Write a short note on solar saving.
3. Derive expression for payback period

Model Question Paper

MODEL QUESTION PAPER  
APJ ABDUL KALAM TECHNOLOGICAL UNIVERSITY  
VII SEMESTER B.TECH DEGREE EXAMINATION  
MET445 RENEWABLE ENERGY ENGINEERING

Maximum: 100 Marks

Duration: 3 hours

PART A

Answer all questions, each question carries 3 marks

1. Discuss in brief advantages of renewable energy.
2. Explain the following terms related to solar geometry (i) Hour Angle ((ii) Zenith Angle (iii) Surface azimuth angle
3. List different types of solar collectors
4. Discuss about solar pond
5. List the different methods used to estimate wind speed at a location.
6. What are the advantages of wind energy conversion systems?
7. List the geothermal resources.
8. Discuss advantages and disadvantages of a tidal power plant
9. Name the different processes used for hydrogen production
10. List the need for economic analysis of renewable energy system.

(10 X 3 = 30 marks)

PART B

Answer one full question from each module

Module 1

11. Elucidate the necessity of energy storage in the context of renewable sources of energy (14 Marks )
12. (a) Calculate the number of daylight hours in Srinagar for 22nd June .The latitude of Srinagar as  $34^{\circ}05'N$ . (4 Marks)  
(b) Compare the construction and working of Pyranometer and Pyrheliometer. (10 Marks)

Module 2

13. (a) How solar thermal power plants classified. List the methods for converting solar energy into electric power (10 Marks)  
(b) Briefly explain the applications of a solar PV system.. (4 Marks)
14. (a) Draw and explain the operation of flat plate collectors. (10 Marks)  
(b) Explain the thermal methods of energy storage (4 Marks)

### Module 3

15. With a neat diagram explain the construction of a propeller type wind power system (14 marks)
16. (a) Derive the expression for power in the wind turbine. (7 marks)
- b) Explain control mechanism in wind turbines (7 marks)

### Module 4

17. State the principle of Ocean Thermal Energy Conversion (OTEC). Explain working of closed cycle OTEC system. (14 marks)
18. . Explain binary cycle Geothermal system (14 marks)

### Module 5

19. Explain the construction and working of KVIC (floating type) bio gas plant (14 marks)
20. a. Define (1) Payback time (2) Return on investment . (6 marks)
- (3) Life cycle cost (6 marks)
- b. A solar PV system consisting with two lamps, a battery and other associated components cost Rs. 55000. The cost of conventional energy saved due to its installation is Rs. 4000 in the first year and this cost inflates at the rate of 5 % per year. Assume discounting rate is 9%. Calculate the payback period of the system with and without discounting (8 marks)

## Syllabus

### Module 1

The Energy Scenario- Commercial energy sources -World's production and reserves-India' Production and reserves, Energy Alternatives, Need for alternatives –solar option-nuclear options

Principles of solar radiation : Solar radiation outside the earth's atmosphere and at the earth's surface , Solar Constant, Basic Sun-Earth Angles, Instruments for measuring solar radiation and sunshine , Solar radiation data

### Module 2

Solar Energy collectors: Solar thermal collectors -Flat plate collectors –Solar concentrators (parabolic trough, parabolic dish, Central Tower Collector) –Solar Air Heaters

Solar thermal electric power generation -Thermal Energy storage, sensible heat storage, latent heat storage , Thermo chemical storage , photovoltaic system for power generation , Solar pond -Solar Cells-Types of solar cells , principle of working and performance characteristics, Production process- Block diagram only

Applications- Solar space heating and cooling of buildings, solar pumping, solar cooker, solar still, solar drier, solar refrigeration and air-conditioning, heliostat, solar furnace

### Module 3

Wind Energy- classification of wind turbines and power performance curve, Energy in wind, calculation of energy content, Power coefficients, Betz limit theory, , tip speed ratio, solidity of turbine' power control strategies, Basic principles of Wind Energy Conversion Systems (WECS), Classification of WECS, Parts of WECS

### Module 4

Ocean Energy – Devices for Wave Energy conversion, Ocean Thermal Energy Conversion (OTEC): Principle of OTEC system, Methods of OTEC power generation – Open Cycle (Claude cycle), Closed Cycle (Anderson cycle) and Hybrid cycle (block diagram description of OTEC); Geothermal energy: Introduction, hot dry rock resources, magma resources, vapor and liquid dominated systems, binary cycle, advantages and disadvantages

### Module 5

Bio Mass Energy- Biomass conversion technologies –Bio Gasification, Bio ethanol, Bio Diesel , Biogas production from waste biomass, factors affecting biogas generation Bio Gas -KVIC and Janata model ,Hydrogen Energy – various routes for production of Hydrogen energy,

Economic Analysis – Initial and annual cost, basic definitions, present worth calculations, repayment of loan in equal annual installments, annual savings, cumulative saving and life cycle cost, economic analysis of add on solar system, payback period(derivation)

### Text Books:

1. S P Sukhatme , J K Nayak, Solar Energy: Principles of Thermal Collection and Storage, Mc Graw Hill ,2015
2. Tiwari G N, Ghosal M K ,Fundamentals of renewable energy sources, Alpha Science International Ltd.,2007
3. Jefferson W Tester et.a., Sustainable Energy Choosing among options,PHI,2006

### Reference Books:

1. D.P. Kothari Renewable energy resources and emerging technologies, Prentice Hall of India Pvt. Ltd,2011
2. Mehmet KanoğluYunus A. Çengel John M. Cimbala , Fundamentals and Applications of Renewable Energy, Mc Graw Hill ,2019
3. Roland Wengenmayr, Thomas Buhrke, 'Renewable Energy: Sustainable energy concepts for the future, Wiley – VCH, 2012

Course Contents and Lecture Schedule

No.	Topic	No. of Lectures
1	The Energy Scenario	(5)
1.1	Commercial energy sources -World's production and reserves India' Production and reserves	1
1.2	Energy Alternatives- Need for alternatives –solar options	1
	Principles of solar radiation	
1.3	Solar radiation outside the earth's atmosphere and at the earth's surface , Solar Constant,	1
1.4	Basic Sun-Earth Angles, Instruments for measuring solar radiation and sunshine , Solar radiation data	2
2	Solar Energy	(11)
2.3	Solar thermal collectors -Flat plate collectors	2
2.4	Solar concentrators (parabolic trough, parabolic dish, Central Tower Collector	2
2.5	Solar Air Heaters-types - Solar thermal electric power generation Thermal Energy storage, sensible heat storage, latent heat storage , Thermo chemical storage	2
2.7	Photovoltaic system for power generation	2
2.8	Solar Cells-Types of solar cells , principle of working and performance characteristics, Production process- Block diagram only	2
2.9	Applications- Solar space heating and cooling of buildings, solar pumping, solar cooker, solar still, solar drier, solar refrigeration and air-conditioning, heliostat, solar furnace	1
3	Wind Energy	(6)
3.1	Classification of wind turbines	1
3.2	power performance curve, Energy in wind, calculation of energy content,	2
3.3	Power coefficients, Betz limit theory, , tip speed ratio, solidity of turbine' power control strategies	2
3.4	Basic principles of Wind Energy Conversion Systems (WECS), Classification of WECS, Parts of WECS	1
4	Ocean Energy	(6)
4.1	Devices for Wave Energy conversion Ocean Thermal Energy Conversion (OTEC): Principle of OTEC system,	1

4.2	Methods of OTEC power generation – Open Cycle (Claude cycle), Closed Cycle (Anderson cycle) and Hybrid cycle (block diagram description of OTEC)	2
4.3	Geothermal energy: Introduction , hot dry rock resources, magma resources	1
4.4	vapor and liquid dominated systems, binary cycle, advantages and disadvantages	2
5	Bio Mass Energy	(8)
5.1	Biomass conversion technologies –Bio Gasification, Bio ethanol, Bio Diesel	1
5.2	Biogas production from waste biomass, factors affecting biogas generation Bio Gas -KVIC and Janata model.	2
5.3	Hydrogen Energy – various routes for production of Hydrogen energy	1
5.3	Economic Analysis – Initial and annual cost, basic definitions,	1
5.4	present worth calculations, repayment of loan in equal annual installments, annual savings, cumulative saving and life cycle cost	2
5.5	economic analysis of add on solar system, payback period(derivation)	1



COURSE CODE	COURSE NAME	CATEGORY	L	T	P	CREDITS
22MEO703.5	QUALITY ENGINEERING AND MANAGEMENT	O	2	1	0	3

Preamble: This course is designed to facilitate the students to understand the concept and culture of total quality management. It empowers the students by inculcating the skills to use quality control techniques and other quality tools in solving quality-related problems and apply these principles in an industry. This course will also amalgamate their knowledge about the importance of customer satisfaction through desired quality at a competitive price.

Prerequisite: NIL

Course Outcomes: After the completion of the course the student will be able to

CO 1	To be conversant with important terms for quality management in organisations
CO 2	Have a complete theoretical and practical understanding of the contributions of Quality Gurus
CO 3	Demonstrate knowledge of the underlying principles of strategic quality management
CO 4	Identify various human dimensions of TQM
CO 5	Implement different tools and techniques in TQM
CO 6	Implement different statistical quality control techniques

Mapping of course outcomes with program outcomes

	PO 1	PO 2	PO 3	PO 4	PO 5	PO 6	PO 7	PO 8	PO 9	PO 10	PO 11	PO 12
CO 1	3					2						3
CO 2	2											2
CO 3	2	2	2						3		1	3
CO 4	3					3			3		1	3
CO 5	2	3	3	2	2				2		2	2
CO 6	2	3	3	2	2				2		2	2

Assessment Pattern

Bloom's Category	Continuous Assessment Tests		End Semester Examination (in %)
	1 (in %)	2 (in %)	
Remember	20	20	20
Understand	60	40	40
Apply	20	40	40
Analyse			
Evaluate			
Create			

### Mark distribution

Total Marks	CIE Marks	ESE Marks	ESE Duration
150	50	100	3 hours

### Continuous Internal Evaluation Pattern:

Attendance	: 10 marks
Continuous Assessment Test (2 numbers)	: 25 marks
Assignment/Quiz/Course project	: 15 marks

End Semester Examination Pattern: There will be two parts; Part A and Part B. Part A contain 10 questions with 2 questions from each module, having 3 marks for each question. Students should answer all questions. Part B contains 2 questions from each module of which student should answer any one. Each question can have maximum 2 sub-divisions and carry 14 marks.

### Course Level Assessment Questions

#### Course Outcome 1 (CO1):

1. Distinguish between quality control and inspection.
2. What are the TQM axioms?
3. What are the enablers of total quality?

#### Course Outcome 2 (CO2)

1. Describe the Deming approach to TQM.
2. List out Crosby's fourteen steps for quality improvement.
3. Describe Juran's quality trilogy.

#### Course Outcome 3(CO3):

1. Define strategic quality management.
2. With examples, describe the classification of quality costs.
3. Describe the concepts of Kaizen approach.

Course Outcome 4 (CO4):

1. What is meant by employee empowerment with respect to total quality management?
2. What are self managing teams?
3. Describe the importance of leadership in TQM

Course Outcome 5 (CO5):

1. "X and R charts always go hand in hand". Elaborate.
2. What are the measures of Central tendency and dispersion?
3. Describe the principles of cause and effect diagram.

Course Outcome 6 (CO6):

1. Explain a typical OC curve for a control chart?
2. What are the effects of sample size on control limits?
3. Enumerate the differences between destructive and non-destructive testing methods.

Model Question Paper

SEVENTH SEMESTER B.TECH DEGREE

EXAMINATION

Course Code: MET455

Course Name: Quality Engineering and Management

Max. Marks: 100

Duration: 3 Hours

PART A

Answer ALL questions, each carries 3 marks.

1. Define the term "Quality control".
2. What are the enablers of total quality?
3. Describe the concept of Quality Function Deployment
4. What are the obstacles to achieving successful strategic quality management?
5. What is meant by employee empowerment?
6. Describe the importance of leadership in TQM
7. What are the applications of control charts?
8. Differentiate between 100% inspection and sampling with suitable examples.
9. Describe the principles of cause and effect diagram.
10. What are the benefits of quality auditing?

PART B

11. a) Compare Juran and Deming approaches (7)  
b) Explain the characteristics of Total Quality Management. (7)

OR

- 12 a) Explain the three TQM axioms. (12)  
b) Define Quality Planning. (2)

13. Describe the steps to be followed to integrate quality into strategic management journey of an organization. (14)

OR

14. (a) Enumerate the objectives of 5S (7)  
(b) Describe the components of Quality cost. (7)

15. What are self managing teams? What are the benefits and problems associated with them? Indicate the key steps to be followed to implement them in organizations. (14)

OR

16. What are the ingredients for success for a quality director? What are the activities to be carried out by a quality director towards assisting upper management with strategic management (14)

17. With the aid of examples, describe the types of failure. (14)

OR

18. What are the different phases of a bath tub curve? With the help of a sketch, illustrate the important features of each phase. (14)

19. Describe the steps to be followed for conducting a quality audit. (14)

OR

20. Following are the data on the quality costs incurred in a manufacturing company in a month:

Title of the quality cost	Amount in Rupees
Product audits	1,000
Scrap Disposal	50,000
Concessions and Downgrading	40,000
Calibration	2,000
Quality planning	500
Manufacturing losses	30,000
System failure	40,000
Test materials	5,000
Training	2,000
Customer returns	25,000

Classify the above quality costs into preventive, appraisal and failure costs. Conduct Pareto analysis and comment on the results. Suggest a proposal with anticipation on the quality costs observable in future. (14)

## Syllabus

### Module 1

Introduction to Quality Engineering - Definitions of the terms - quality, quality planning, quality control, quality assurance, quality management, Total Quality Management (TQM)- overview on TQM - the TQM axioms - consequences of total quality- Barriers to TQM- Deming approach to TQM – Juran’s quality trilogy- Crosby's fourteen steps for quality improvement

### Module 2

Strategic Quality Management: Cost of Quality- Customer satisfaction- Quality Function Deployment (QFD)- Integrating quality into strategic management - obstacles to achieving successful strategic quality management- Concepts of 5S, Six Sigma, Kaizen.

### Module 3

Human dimensions of TQM – Top management commitment- Leadership for TQM- Change management- resources for quality activities - training for quality –Employee involvement, motivation empowerment- teamwork- self managing teams - role of the quality director- Quality System: ISO 9000 family of standards.

### Module 4

Quality control and Inspection- Destructive and non-destructive testing methods- process capability- Statistical quality control –Acceptance sampling- causes of variation in quality- control charts for X and R, Problems- Reliability-types and causes of failures- Bath tub curve.-System reliability- life testing.

### Module 5

Supporting Tools, Activities And Techniques in TQM Projects : Affinity diagram - brainstorming - cause and effect analysis - process flow chart – check sheets- Scatter diagram - Pareto chart- Histogram and fundamentals of statistics - Taguchi’s robust design- Total Productive maintenance- Failure Mode and Effect Analysis - Quality auditing- types and benefits.

### Text Books

1. Besterfield Dale H. , Besterfield Carol, Besterfield Glen H., Besterfield Mary, Urdhwareshe Hemant, Urdhwareshe Rashmi, “Total Quality Management (TQM) 5e”, Pearson Education, 2018.
2. Subburaj Ramasamy, “Total Quality Management”, McGraw Hill Education,, 2017.
3. Dr. K.C. Arora, “Total Quality Management”, S K Kataria and Sons, 2013.
4. Suganthi, L and Anand A Samuel, “Total Quality Management”, Prentice Hall India Learning Private Limited, 2009.

5. Juran J M and Gryna, F M, "Quality Planning and Analysis - From Product Development through Use", Tata McGraw Hill Publishing Limited, New Delhi, Third Edition, 2004.

#### Reference Books

1. Logothetics N, "Managing for Total Quality - From Deming to Taguchi and SPC", Prentice Hall Ltd., New Delhi, 1997.
2. Deming W E, "Out of the Crisis," MIT Press, Cambridge, MA, 1982.
3. Juran J M and Juran on "Leadership for Quality" An Executive Handbook, The Free Press, New York, 1989.
4. Salor J H, "TQM-Field Manual," McGraw Hill, New York, 1992.
5. Crosby P B, "Quality is Free" McGraw Hill, New York, 1979.

#### Course Contents and Lecture Schedule

No	Topic	No. of Lectures
1	Introduction to Quality Engineering	
1.1	Definitions of the terms - quality, quality planning, quality control, quality assurance, quality management	2
1.2	Total Quality Management (TQM)- overview on TQM - the TQM axioms - consequences of total quality- Barriers to TQM	2
1.3	Deming approach to TQM - Juran quality trilogy- Crosby's fourteen steps for quality improvement	3
2	Strategic Quality Management	
2.1	Cost of Quality- Customer satisfaction- Quality Function Deployment (QFD)	2
2.2	Integrating quality into strategic management - quality and the management cycle	1
2.3	obstacles to achieving successful strategic quality management	1
2.4	Concepts of 5S, Six Sigma, Kaizen	2
3	Human dimensions of TQM	
3.1	Top management commitment- Leadership for TQM- Change management	2
3.2	Resources for quality activities - training for quality	1
3.3	Employee involvement, motivation, empowerment	2
3.3	Teamwork- self managing teams - role of the quality director	1
3.4	Quality System: ISO 9000 family of standards.	1
4	Quality control and Inspection	
4.1	Destructive and non-destructive testing methods	1
4.2	Process capability- Statistical quality control –acceptance sampling- causes of variation in quality	2
4.3	Control charts for X and R. Reliability-	3

4.4	causes of failures- Bath tub curve	1
4.5	System reliability- life testing	1
5	Supporting Tools, Activities And Techniques in TQM Projects	
5.1	Affinity diagram - brainstorming	1
5.2	Cause and effect analysis - process flow chart – check sheets- Scatter diagram - Pareto chart	3
5.3	Histogram and fundamentals of statistics	1
5.4	Taguchi's robust design- Total Productive maintenance- Failure Mode and Effect Analysis	2
5.5	Quality auditing- types and benefits	1



COURSE CODE	COURSE NAME	CATEGORY	L	T	P	CREDITS
22MET704	INDUSTRIAL SAFETY ENGINEERING	MCN	2	1	0	-

**Preamble:** The course is intended to give knowledge of various safety management principles, various safety systems, various machine guarding devices, hazard identification techniques, energy sources, systems & applications and the need in the present context. Learners will be able to compare different hazard identification tools and choose the most appropriate based on the nature of industry. It aims to equip students in working with projects and to take up research work in connected areas

**Prerequisite:** Nil

**Course Outcomes:** After the completion of the course the student will be able to

<b>CO1</b>	Describe the theories of accident causation and preventive measures of industrial accidents. (Cognitive Knowledge level: <b>Understand</b> )
<b>CO2</b>	Explain about personal protective equipment, its selection, safety performance & indicators and importance of housekeeping. (Cognitive Knowledge level: <b>Understand</b> )
<b>CO3</b>	Explain different issues in construction industries. (Cognitive Knowledge level: <b>Understand</b> )
<b>CO4</b>	Describe various hazards associated with different machines and mechanical material handling. (Cognitive Knowledge level: <b>Understand</b> )
<b>CO5</b>	Utilise different hazard identification tools in different industries with the knowledge of different types of chemical hazards. (Cognitive Knowledge level: <b>Apply</b> )

### Mapping of course outcomes with program outcomes

	PO1	PO2	PO3	PO4	PO5	PO6	PO7	PO8	PO9	PO10	PO11	PO12
CO1	2	2				2	2	2				1
CO2	2	1	2		1	1	1	1				1
CO3	2	2	2		1	1	1	1	1	1		1
CO4	2	2	2		1	1	1	1	1	1		1
CO5	2	2	2	1	1	1	1	1	1	1		1

Abstract POs defined by National Board of Accreditation				
PO1	Engineering Knowledge		PO7	Environment and Sustainability
PO2	Problem Analysis		PO8	Ethics
PO3	Design/Development of solutions		PO9	Individual and team work
PO4	Conduct investigations of complex problems		PO10	Communication
PO5	Modern tool usage		PO11	Project Management and Finance
PO6	The Engineer and Society		PO12	Life long learning

### Assessment Pattern

	Continuous Assessment Tests		End Semester Examination
	1	2	
Remember	10	10	10
Understand	20	20	20
Apply	20	20	70
Analyse			
Evaluate			
Create			

**Mark distribution:**

<b>Total Marks</b>	<b>CIE Marks</b>	<b>ESE Marks</b>	<b>ESE Duration</b>
<b>150</b>	<b>50</b>	<b>100</b>	<b>3 hours</b>

**Continuous Internal Evaluation Pattern:**

Attendance : 10 marks

Continuous Assessment - Test : 25 marks

Continuous Assessment - Assignment : 15 marks

**Internal Examination Pattern:**

Each of the two internal examinations has to be conducted out of 50 marks. First series test shall be preferably conducted after completing the first half of the syllabus and the second series test shall be preferably conducted after completing remaining part of the syllabus. There will be two parts: Part A and Part B. Part A contains 5 questions (preferably, 2 questions each from the completed modules and 1 question from the partly completed module), having 3 marks for each question adding up to 15 marks for part A. Students should answer all questions from Part A. Part B contains 7 questions (preferably, 3 questions each from the completed modules and 1 question from the partly completed module), each with 7 marks. Out of the 7 questions, a student should answer any 5.

**End Semester Examination Pattern:**

There will be two parts; Part A and Part B. Part A contains 10 questions with 2 questions from each module, having 3 marks for each question. Students should answer all questions. Part B contains 2 questions from each module of which a student should answer any one. Each question can have maximum 2 sub-divisions and carries 14 marks.

## **Syllabus**

### **MCN401- Industrial Safety Engineering (35 hrs)**

#### **Module I (Safety introduction- 5 hrs)**

Need for safety. Safety and productivity. Definitions: Accident, Injury, Unsafe act, Unsafe Condition, Dangerous Occurrence, Reportable accidents. Theories of accident causation. Safety organization-objectives, types, functions, Role of management, supervisors, workmen, unions, government and voluntary agencies in safety. Safety policy. Safety Officer-responsibilities, authority. Safety committee-need, types, advantages.

#### **Module II (Personal protection in work environment- 7 hrs)**

Personal protection in the work environment, Types of PPEs, Personal protective equipment- respiratory and non-respiratory equipment. Standards related to PPEs. Monitoring Safety Performance: Frequency rate, severity rate, incidence rate, activity rate. Housekeeping: Responsibility of management and employees. Advantages of good housekeeping. 5 s of housekeeping. Work permit system- objectives, hot work and cold work permits. Typical industrial models and methodology. Entry into confined spaces.

#### **Module III (Safety issues in construction- 7 hrs)**

Introduction to construction industry and safety issues in construction Safety in various construction operations – Excavation and filling – Under-water works – Under-pinning & Shoring – Ladders & Scaffolds – Tunneling – Blasting – Demolition – Confined space – Temporary Structures. Familiarization with relevant Indian Standards and the National Building Code provisions on construction safety. Relevance of ergonomics in construction safety. Ergonomics Hazards - Musculoskeletal Disorders and Cumulative Trauma Disorders.

#### **Module IV (Safety hazards in machines- 8 hrs)**

Machinery safeguard-Point-of-Operation, Principle of machine guarding -types of guards and devices. Safety in turning, and grinding. Welding and Cutting-Safety Precautions of Gas

welding and Arc Welding. Material Handling-Classification-safety consideration- manual and mechanical handling. Handling assessments and techniques- lifting, carrying, pulling, pushing, palletizing and stocking. Material Handling equipment-operation & maintenance. Maintenance of common elements-wire rope, chains slings, hooks, clamps. Hearing Conservation Program in Production industries.

### **Module V (Hazard identification and analysis- 8 hrs)**

Hazard and risk, Types of hazards –Classification of Fire, Types of Fire extinguishers, fire explosion and toxic gas release, Structure of hazard identification and risk assessment. Identification of hazards: Inventory analysis, Fire and explosion hazard rating of process plants  
- The Dow Fire and Explosion Hazard Index, Preliminary hazard analysis, Hazard and Operability study (HAZOP)) – methodology, criticality analysis, corrective action and follow-up. Control of Chemical Hazards, Hazardous properties of chemicals, Material Safety Data Sheets (MSDS).

#### **Text Books:**

1. R.K Jain (2000) Industrial Safety, Health and Environment management systems, Khanna Publications.
2. Paul S V (2000), Safety management System and Documentation training Programme handbook, CBS Publication.
3. Krishnan, N.V. (1997). *Safety management in Industry*. Jaico Publishing House, New Delhi.
4. John V. Grimaldi and Rollin H. Simonds. (1989) *Safety management*. All India Traveller Book Seller, Delhi.
5. Ronald P. Blake. (1973). *Industrial safety*. Prentice Hall, New Delhi.
6. Alan Waring. (1996). *Safety management system*. Chapman & Hall, England.
7. Vaid, K.N., (1988). Construction safety management. National Institute of Construction Management and Research, Mumbai.
8. AIChE/CCPS. (1992). *Guidelines for Hazard Evaluation Procedures*. (second edition). Centre for Chemical Process Safety, American Institute of Chemical Engineers, New York.

**Course Level Assessment Questions:**

**Course Outcome 1 (CO1):**

1. Which are the various accident causation theories? Explain.
2. Define terms: Accident, Reportable accident, Dangerous occurrence.

**Course Outcome 2 (CO2):**

1. Discuss different types of personal protective equipment
2. Discuss about how to compare the safety performance of two industries.
3. Discuss the significance of work permit system in accident prevention.

**Course Outcome 3 (CO3):**

1. Distinguish ladders and scaffolds along with their safety features.
2. Discuss the safety requirement for a confined space entry.
3. Explain the important provision in the National Building Code.

**Course Outcome 4 (CO4):**

1. Explain the various principles used in machine guarding.
2. Explain the issues in mechanical material handling.

**Course Outcome 5 (CO5):**

1. Selection of different types of fire extinguishers accordance to type of fire.
2. Conduct a HAZOP study for a batch reactor of your choice.
3. Determine different types of Chemical hazards associated with industries

**Model Question Paper**

**APJ ABDUL KALAM TECHNOLOGICAL UNIVERSITY  
VII SEMESTER B. TECH DEGREE EXAMINATION  
MCN401- INDUSTRIAL SAFETY ENGINEERING**

**Maximum: 100 Marks**

**Duration: 3 hours**

**PART A**

**Answer all questions, each question carries 3 marks**

1. Differentiate Unsafe act and Unsafe conditions with suitable examples
2. Discuss the significance of a safety committee in improving the safety performance of an industry
3. Which are the different types of permit? Highlight its suitability.
4. Which are five 'S' used in housekeeping?
5. List the various safety features of ladders.
6. How safety of the workers can be ensured during a demolition operations.
7. Which are the hazards associated with manual material handling?
8. Discuss the safety issues of Gas welding operations.
9. Differentiate Hazard and Risk.
10. Why MSDS is mandatory for chemical products.

(10 X 3 = 30 Marks)

**PART B**

**Answer one full question from each module**

**Module 1**

11. List the various accident causation theories and explain any one in details. (14 Marks)
12. a) Discuss the significance of safety policy in reducing the accidents. (4 Marks)  
b) Safety and productivity are the two sides of a coin'. Are you agreeing with this statement? Explain with your arguments. (10 Marks)

**Module 2**

13. a) Classify the personal protective equipment. List the suitability of at least fifteen types of PPEs. (10 Marks)

b) How will you calculate the frequency rate? Explain with an example. (4 Marks)

14. a) How will you compare the safety performance of two industries? Explain with suitable example. (10 Marks)

b) Which are the steps to be followed in confined space entry to protect the life a worker. (4 Marks)

### **Module 3**

15. Discuss the safety and fire protection facilities required for a high rise building as per National building code. (14 Marks)

16. a) Identify the various hazards during the different stages of building construction. (7 Marks)

b) Discuss the important types of ergonomic hazards associated with industries.(7 Marks)

### **Module 4**

17. Which are the various types of machine guarding devices used industries. Discuss the suitability of each machine guarding devices. (14 Marks)

18. With suitable sketches briefly explain seven defects of wire ropes. (14 Marks)

### **Module 5**

19. What is Hazard and Operability Analysis? How do you conduct a HAZOP analysis? (14 Marks)

20. Discuss about different types of chemical hazards. (14 Marks)



## Course Contents and Lecture Schedule

No.	Topic	No. of Lectures/ Tutorials L-T
1	<b>Introduction to Industrial safety Engineering</b>	
1.1	Need for safety. Safety and productivity. Definitions: Accident, Injury, Unsafe act, Unsafe Condition, Dangerous Occurrence. Reportable accidents	1
1.2	Theories of accident causation. Safety organization.	2
1.3	Role of management, supervisors, workmen, unions, government and voluntary agencies in safety.	3
1.4	Safety Officer-responsibilities, authority.	4
1.5	Safety committee-need, types, advantages.	5
2	<b>Personal protection in the work environment</b>	
2.1	Types of PPEs, respiratory and non-respiratory equipment.	6
2.2	Standards related to PPEs	7
2.3	Monitoring Safety Performance: Frequency rate, severity rate	8,
2.4	Monitoring Safety Performance: incidence rate, activity rate.	9
2.5	Housekeeping: Responsibility of management and employees. Advantages of good housekeeping. 5 s of housekeeping.	10
2.6	Work permit system- objectives, hot work and cold work permits.	11
2.7	Typical industrial models and methodology. Entry into confined spaces.	12
3	<b>Introduction to construction industry and safety</b>	
3.1	Excavation and filling – Under-water works – Under-pinning & Shoring	13
3.2	Ladders & Scaffolds – Tunneling	14
3.3	Blasting –Demolition – Confined space	15
3.4	Familiarization with relevant Indian Standards and the National Building Code provisions on construction safety.	16
3.5	Relevance of ergonomics in construction safety.	17
3.6	Ergonomics Hazards	18

3.7	Musculoskeletal Disorders and Cumulative Trauma Disorders.	19
4	<b>Machinery safeguard</b>	
4.1	Point-of-Operation, Principle of machine guarding -	20
4.2	Types of guards and devices.	21
4.3	Safety in Power Presses, primary & secondary operations - shearing -bending - rolling – drawing.	22
4.4	Safety in turning, boring, milling, planning and grinding.	23
4.5	Welding and Cutting-Safety Precautions of Gas welding and Arc Welding,	24
4.6	Cutting and Finishing.	25
4.7	Material Handling-Classification-safety consideration- manual and mechanical handling. Handling assessments and techniques- lifting, carrying, pulling, pushing, palletizing and stocking.	26
4.8	Material Handling equipment-operation & maintenance. Maintenance of common elements-wire rope, chains slings, hooks, clamps	27
5	<b>Hazard identification</b>	
5.1	Hazard and risk, Types of hazards – Classification of Fire	28
5.2	Types of Fire extinguishers fire, explosion and toxic gas release.	29
5.3	Inventory analysis, Fire and explosion hazard rating of process plants	30
5.4	The Dow Fire and Explosion Hazard Index.	31
5.5	Preliminary hazard analysis, Hazard and Operability study (HAZOP)	32
5.6	Chemical hazard- Classifications, Control of Chemical Hazards.	33
5.7	Hazardous properties of chemicals	34
5.8	Material Safety Data Sheets (MSDS).	35

COURSE CODE	COURSE NAME	CATEGORY	L	T	P	CREDITS
22MEL705	MECHANICAL ENGINEERING LAB	PCC	0	0	3	2

**Preamble:** The course is intended to enable the students to get an exposure to equipment and exercises related to machine dynamics, cutting forces in milling machine, basics of pneumatic and hydraulic devices, basic concepts of stepper motors, basic ideas of data acquisition systems and automation.

**Prerequisite:** Should have undergone courses on Engineering Mechanics, Theory of Machines, Machine Tools.

**Course Outcomes:** After completion of the course the student will be able to

<b>CO 1</b>	Get practical knowledge on design and analysis of mechanisms in the machines.
<b>CO 2</b>	Measure the cutting forces associated with milling machining operations.
<b>CO 3</b>	Apply the basic concepts of hydraulic and pneumatic actuators and their applications in product and processes
<b>CO 4</b>	Use appropriate systems for data acquisition and control of product and processes

### Mapping of course outcomes with program outcomes

	PO 1	PO 2	PO 3	PO 4	PO 5	PO 6	PO 7	PO 8	PO 9	PO 10	PO 11	PO 12
<b>CO 1</b>	3	2	2	3	3		2		3	2		2
<b>CO 2</b>	3	2	2	3	3		2		3	2		2
<b>CO 3</b>	3	2	2	3	3		2		3	2		2
<b>CO 4</b>	3	2	2	3	3		2		3	2		2

### Assessment Pattern

#### Mark distribution

Total Marks	CIE	ESE	ESE Duration
150	75	75	2.5 hours

### Continuous Internal Evaluation Pattern:

Attendance	:	15 marks
Continuous Assessment	:	30 marks
Internal Test (Immediately before the second series test)	:	30 marks

**End Semester Examination Pattern:** The following guidelines should be followed regarding award of marks

(a) Preliminary work	:	15 Marks
(b) Implementing the work/Conducting the experiment	:	10 Marks
(c) Performance, result and inference (usage of equipments and trouble shooting)	:	25 Marks
(d) Viva voce	:	20 marks
(e) Record	:	5 Marks

**General instructions:** Practical examination to be conducted immediately after the second series test covering entire syllabus given below. Evaluation is a serious process that is to be conducted under the equal responsibility of both the internal and external examiners. The number of candidates evaluated per day should not exceed 20. Students shall be allowed for the University examination only on submitting the duly certified record. The external examiner shall endorse the record.

**List of Exercises/Experiments:** (Lab experiments may be given considering 12 sessions of 3 hours each. Minimum 10 experiments to be performed.)

1. Experiment on Whirling of shaft
2. Experiment on Gyroscope
3. Experiment on Universal governor apparatus
4. Experiment on Free vibration analysis
5. Experiment on Forced vibration analysis
6. Experiment on any Non destructive test.
7. Exercises on Milling Machine - slab milling/gear cutting
8. Milling forces – Milling parameters – measurement of milling forces in slab milling operations
9. Exercises on pneumatic circuits using pneumatic trainer unit
10. Exercises on hydraulic circuits using hydraulic trainer unit
11. Exercises on electro pneumatic and electro hydraulic circuits using trainer units
12. Exercises on 3-D printing
13. Exercises on Motion controller using AC/DC motor, servo motors and encoders to determine the operating characteristics.
14. Exercises on stepper motor to determine the operating characteristics.
15. Exercises on PC based data acquisition system with any software.
16. Study of SCADA and PLC programming
17. Interfacing SCADA with PLC and PC.
18. Controlling variable speed drive through PLC/SCADA

## Reference Books

1. C.E.Wilson, P. Sadler, Kinematics and Dynamics of Machinery, Pearson Education, 2005
2. D.H.Myskza, Machines and Mechanisms Applied Kinematic Analysis, Pearson Education, 2013
3. W.Bolton, Mechatronics: Electronic Control Systems in Mechanical and Electrical Engineering, Person Education Limited, New Delhi, 2007
4. K.P.Ramachandran, G.K.Vijayaraghavan, M.S.Balasundaram, Mechatronics: Integrated Mechanical Electronic Systems, Wiley India Pvt. Ltd., New Delhi, 2008.
5. Serope Kalpakjian, Steven R. Schmid - Manufacturing Engineering and Technology, Pears

COURSE CODE	COURSE NAME	CATEGORY	L	T	P	CREDITS
22MES706	SEMINAR	PWS	0	0	3	2

**Preamble:** The course ‘Seminar’ is intended to enable a B.Tech graduate to read, understand, present and prepare report about an academic document. The learner shall search in the literature including peer reviewed journals, conference, books, project reports etc., and identify an appropriate paper/thesis/report in her/his area of interest, in consultation with her/his seminar guide. This course can help the learner to experience how a presentation can be made about a selected academic document and also empower her/him to prepare a technical report.

#### Course Objectives:

- To do literature survey in a selected area of study.
- To understand an academic document from the literature and to give a presentation about it.
- To prepare a technical report.

**Course Outcomes [COs] :** After successful completion of the course, the students will be able to:

CO1	Identify academic documents from the literature which are related to her/his areas of interest (Cognitive knowledge level: <b>Apply</b> ).
CO2	Read and apprehend an academic document from the literature which is related to her/ his areas of interest (Cognitive knowledge level: <b>Analyze</b> ).
CO3	Prepare a presentation about an academic document (Cognitive knowledge level: <b>Create</b> ).
CO4	Give a presentation about an academic document (Cognitive knowledge level: <b>Apply</b> ).
CO5	Prepare a technical report (Cognitive knowledge level: <b>Create</b> ).

#### Mapping of course outcomes with program outcomes:

	PO1	PO2	PO3	PO4	PO5	PO6	PO7	PO8	PO9	PO10	PO11	PO12
<b>CO1</b>	2	2	1	1		2	1					3
<b>CO2</b>	3	3	2	3		2	1					3
<b>CO3</b>	3	2			3			1		2		3
<b>CO4</b>	3				2			1		3		3
<b>CO5</b>	3	3	3	3	2	2		2		3		3

<b>Abstract POs defined by National Board of Accreditation</b>			
<b>PO#</b>	<b>Broad PO</b>	<b>PO#</b>	<b>Broad PO</b>
PO1	Engineering Knowledge	PO7	Environment and Sustainability
PO2	Problem Analysis	PO8	Ethics
PO3	Design/Development of solutions	PO9	Individual and team work
PO4	Conduct investigations of complex problems	PO10	Communication
PO5	Modern tool usage	PO11	Project Management and Finance
PO6	The Engineer and Society	PO12	Life long learning

### **General Guidelines**

- The Department shall form an Internal Evaluation Committee (IEC) for the seminar with academic coordinator for that program as the Chairperson/Chairman and seminar coordinator & seminar guide as members. During the seminar presentation of a student, all members of IEC shall be present.
- Formation of IEC and guide allotment shall be completed within a week after the University examination (or last working day) of the previous semester.
- Guide shall provide required input to their students regarding the selection of topic/paper.
- Choosing a seminar topic: The topic for a UG seminar should be current and broad based rather than a very specific research work. It's advisable to choose a topic for the Seminar to be closely linked to the final year project area. Every member of the project team could choose or be assigned Seminar topics that covers various aspects linked to the Project area.
- A topic/paper relevant to the discipline shall be selected by the student during the semester break.
- Topic/Paper shall be finalized in the first week of the semester and shall be submitted to the IEC.
- The IEC shall approve the selected topic/paper by the second week of the semester.
- Accurate references from genuine peer reviewed published material to be given in the report and to be verified.

## **Evaluation pattern**

**Total marks: 100, only CIE, minimum required to pass 50**

**Seminar Guide:** 20 marks (Background Knowledge – 10 (The guide shall give deserving marks for a candidate based on the candidate's background knowledge about the topic selected), Relevance of the paper/topic selected – 10).

**Seminar Coordinator:** 20 marks (Seminar Diary – 10 (Each student shall maintain a seminar diary and the guide shall monitor the progress of the seminar work on a weekly basis and shall approve the entries in the seminar diary during the weekly meeting with the student), Attendance – 10).

**Presentation:** 40 marks to be awarded by the IEC (Clarity of presentation – 10, Interactions – 10 (to be based on the candidate's ability to answer questions during the interactive session of her/his presentation), Overall participation – 10 (to be given based on her/his involvement during interactive sessions of presentations by other students), Quality of the slides – 10).

**Report:** 20 marks to be awarded by the IEC (check for technical content, overall quality, templates followed, adequacy of references etc.).



COURSE CODE	COURSE NAME	CATEGORY	L	T	P	CREDITS
22MEP707	PROJECT PHASE I	PWS	0	0	6	2

**Preamble:** The course 'Project Work' is mainly intended to evoke the innovation and invention skills in a student. The course will provide an opportunity to synthesize and apply the knowledge and analytical skills learned, to be developed as a prototype or simulation. The project extends to 2 semesters and will be evaluated in the 7<sup>th</sup> and 8<sup>th</sup> semester separately, based on the achieved objectives. One third of the project credits shall be completed in 7<sup>th</sup> semester and two third in 8<sup>th</sup> semester. It is recommended that the projects may be finalized in the thrust areas of the respective engineering stream or as interdisciplinary projects. Importance should be given to address societal problems and developing indigenous technologies.

#### Course Objectives

- To apply engineering knowledge in practical problem solving.
- To foster innovation in design of products, processes or systems.
- To develop creative thinking in finding viable solutions to engineering problems.

**Course Outcomes [COs] :**After successful completion of the course, the students will be able to:

CO1	Model and solve real world problems by applying knowledge across domains (Cognitive knowledge level: <b>Apply</b> ).
CO2	Develop products, processes or technologies for sustainable and socially relevant applications (Cognitive knowledge level: <b>Apply</b> ).
CO3	Function effectively as an individual and as a leader in diverse teams and to comprehend and execute designated tasks (Cognitive knowledge level: <b>Apply</b> ).
CO4	Plan and execute tasks utilizing available resources within timelines, following ethical and professional norms (Cognitive knowledge level: <b>Apply</b> ).
CO5	Identify technology/research gaps and propose innovative/creative solutions (Cognitive knowledge level: <b>Analyze</b> ).
CO6	Organize and communicate technical and scientific findings effectively in written and oral forms (Cognitive knowledge level: <b>Apply</b> ).

#### Mapping of course outcomes with program outcomes

	PO1	PO2	PO3	PO4	PO5	PO6	PO7	PO8	PO9	PO10	PO11	PO12
<b>CO1</b>	2	2	2	1	2	2	2	1	1	1	1	2
<b>CO2</b>	2	2	2		1	3	3	1	1		1	1
<b>CO3</b>									3	2	2	1
<b>CO4</b>					2			3	2	2	3	2
<b>CO5</b>	2	3	3	1	2							1
<b>CO6</b>					2			2	2	3	1	1

**Abstract POs defined by National Board of Accreditation**

<b>PO#</b>	<b>Broad PO</b>	<b>PO#</b>	<b>Broad PO</b>
PO1	Engineering Knowledge	PO7	Environment and Sustainability
PO2	Problem Analysis	PO8	Ethics
PO3	Design/Development of solutions	PO9	Individual and team work
PO4	Conduct investigations of complex problems	PO10	Communication
PO5	Modern tool usage	PO11	Project Management and Finance
PO6	The Engineer and Society	PO12	Lifelong learning

## **PROJECT PHASE I**

### **Phase 1 Target**

- Literature study/survey of published literature on the assigned topic
- Formulation of objectives
- Formulation of hypothesis/ design/ methodology
- Formulation of work plan and task allocation.
- Block level design documentation
- Seeking project funds from various agencies
- Preliminary Analysis/Modeling/Simulation/Experiment/Design/Feasibility study
- Preparation of Phase 1 report

### Evaluation Guidelines & Rubrics

Total: 100 marks (Minimum required to pass: 50 marks).

- Project progress evaluation by guide: 30 Marks.
- Interim evaluation by the Evaluation Committee: 20 Marks.
- Final Evaluation by the Evaluation Committee: 30 Marks.
- Project Phase - I Report (By Evaluation Committee): 20 Marks.

(The evaluation committee comprises HoD or a senior faculty member, Project coordinator and project supervisor).

### **Evaluation by the Guide**

The guide/supervisor shall monitor the progress being carried out by the project groups on a regular basis. In case it is found that progress is unsatisfactory it shall be reported to the Department Evaluation Committee for necessary action. The presence of each student in the group and their involvement in all stages of execution of the project shall be ensured by the guide. Project evaluation by the guide: 30 Marks. This mark shall be awarded to the students in his/her group by considering the following aspects:

**Topic Selection:** innovativeness, social relevance etc. (2)

**Problem definition:** Identification of the social, environmental and ethical issues of the project problem. (2)

**Purpose and need of the project:** Detailed and extensive explanation of the purpose and need of the project. (3)

**Project Objectives:** All objectives of the proposed work are well defined; Steps to be followed to solve the defined problem are clearly specified. (2)

**Project Scheduling & Distribution of Work among Team members:** Detailed and extensive Scheduling with timelines provided for each phase of project. Work breakdown structure well defined. (3)

**Literature survey:** Outstanding investigation in all aspects. (4)

**Student's Diary/ Daily Log:** The main purpose of writing daily diary is to cultivate the habit of documenting and to encourage the students to search for details. It develops the students' thought process and reasoning abilities. The students should record in the daily/weekly activity diary the day to day account of the observations, impressions, information gathered and suggestions given, if any. It should contain the sketches & drawings related to the observations made by the students. The daily/weekly activity diary shall be signed after every day/week by the guide. (7)

**Individual Contribution:** The contribution of each student at various stages. (7)

**EVALUATION RUBRICS for PROJECT Phase I: Interim Evaluation**

No.	Parameters	Marks	Poor	Fair	Very Good	Outstanding
1-a	Topic identification, selection, formulation of objectives and/or literature survey. (Group assessment)  [CO1]	10	The team has failed to come with a relevant topic in time. Needed full assistance to find a topic from the guide. They do not respond to suggestions from the evaluation committee and/or the guide. No literature review was conducted. The team tried to gather easy information without verifying the authenticity. No objectives formed yet.	The team has identified a topic. The originally selected topic lacks substance and needs to be revised. There were suggestions given to improve the relevance and quality of the project topic. Only a few relevant references were consulted/ studied and there is no clear evidence to show the team's understanding on the same. Some objectives identified, but not clear enough.	Good evidence of the group thinking and brainstorming on what they are going to build. The results of the brainstorming are documented and the selection of topic is relevant. The review of related references was good, but there is scope of improvement. Objectives formed with good clarity, however some objectives are not realistic enough.	The group has brainstormed in an excellent manner on what they were going to build. The topic selected is highly relevant, real world problem and is potentially innovative. The group shows extreme interest in the topic and has conducted extensive literature survey in connection with the topic. The team has come up with clear objectives which are feasible.
			(0 – 3 Marks)	(4 – 6 Marks)	(7 - 9 Marks)	(10 Marks)
1-b	Project Planning, Scheduling and Resource/ Tasks Identification and allocation. (Group assessment)  [CO4]	10	No evidence of planning or scheduling of the project. The students did not plan what they were going to build or plan on what materials / resources to use in the project. The students do not have any idea on the budget required. The team has not yet decided on who does what. No project journal kept.	Some evidence of a primary plan. There were some ideas on the materials /resources required, but not really thought out. The students have some idea on the finances required, but they have not formalized a budget plan. Schedules were not prepared. The project journal has no details. Some evidence on task allocation among the team members.	Good evidence of planning done. Materials were listed and thought out, but the plan wasn't quite complete. Schedules were prepared, but not detailed, and needs improvement. Project journal is presented but it is not complete in all respect / detailed. There is better task allocation and individual members understand about their tasks. There is room for improvement.	Excellent evidence of enterprising and extensive project planning. Gantt charts were used to depict detailed project scheduling. A project management/version control tool is used to track the project, which shows familiarity with modern tools. All materials / resources were identified and listed and anticipation of procuring time is done. Detailed budgeting is done. All tasks were identified and incorporated in the schedule. A well-kept project journal shows evidence for all the above, in addition to the interaction with the project guide. Each member knows well about their individual tasks.
			(0 – 3 Marks)	(4 – 6 Marks)	(7 - 9 Marks)	(10 Marks)

**Phase 1 Interim Evaluation Total Marks: 20**

**EVALUATION RUBRICS for PROJECT Phase I: Final Evaluation**

Sl. No.	Parameters	Marks	Poor	Fair	Very Good	Outstanding
1-c	Formulation of Design and/or Methodology and Progress. (Group assessment) [CO1]	5	None of the team members show any evidence of knowledge about the design and the methodology adopted till now/ to be adopted in the later stages. The team has not progressed from the previous stage of evaluation.	The students have some knowledge on the design procedure to be adopted, and the methodologies. However, the team has not made much progress in the design, and yet to catch up with the project plan.	The students are comfortable with design methods adopted, and they have made some progress as per the plan. The methodologies are understood to a large extent.	Shows clear evidence of having a well-defined design methodology and adherence to it. Excellent knowledge in design procedure and its adaptation. Adherence to project plan is commendable.
			(0 – 1 Marks)	(2 – 3 Marks)	(4 Marks)	(5 Marks)
1-d	Individual and Teamwork Leadership ( Individual assessment) [CO3]	10	The student does not show any interest in the project activities, and is a passive member.	The student show some interest and participates in some of the activities. However, the activities are mostly easy and superficial in nature.	The student shows very good interest in project, and takes up tasks and attempts to complete them. Shows excellent responsibility and team skills. Supports the other members well.	The student takes a leadership position and supports the other team members and leads the project. Shows clear evidence of leadership.
			(0 – 3 Marks)	(4 – 6 Marks)	(7 - 9 Marks)	(10 Marks)
1-e	Preliminary Analysis/ Modeling / Simulation/ Experiment / Design/ Feasibility study [CO1]	10	The team has not done any preliminary work with respect to the analysis/modeling/ simulation/experiment/design/feasibility study/ algorithm development.	The team has started doing some preliminary work with respect to the project. The students however are not prepared enough for the work and they need to improve a lot.	There is some evidence to show that the team has done good amount of preliminary investigation and design/ analysis/ modeling etc. They can improve further.	Strong evidence for excellent progress in the project. The team has completed the required preliminary work already and are poised to finish the phase I in an excellent manner. They have shown results to prove their progress.
			(0 – 3 Marks)	(4 – 6 Marks)	(7 - 9 Marks)	(10 Marks)

1-f	Documentation and presentation. (Individual & group assessment).  [CO6]	5	<p>The team did not document the work at all. The project journal/diary is not presented. The presentation was shallow in content and dull in appearance.</p> <p>The individual student has no idea on the presentation of his/her part.</p>	<p>Some documentation is done, but not extensive. Interaction with the guide is minimal.</p> <p>Presentation include some points of interest, but overall quality needs to be improved. Individual performance to be improved.</p>	<p>Most of the project details were documented well enough. There is scope for improvement. The presentation is satisfactory. Individual performance is good.</p>	<p>The project stages are extensively documented in the report. Professional documentation tools like LaTeX were used to document the progress of the project along with the project journal. The documentation structure is well-planned and can easily grow into the project report.</p> <p>The presentation is done professionally and with great clarity. The individual's performance is excellent.</p>
			(0 – 1 Marks)	(2 – 3 Marks)	(4 Marks)	(5 Marks)
<b>Total</b>		<b>30</b>	<b>Phase - I Final Evaluation Marks: 30</b>			

**EVALUATION RUBRICS for PROJECT Phase I: Report Evaluation**

Sl. No.	Parameters	Marks	Poor	Fair	Very Good
1-g	Report [CO6]	20	The prepared report is shallow and not as per standard format. It does not follow proper organization. Contains mostly Unacknowledged content. Lack of effort in preparation is evident.	Project report follows the standard format to some extent. However, its organization is not very good. Language needs to be improved. All references are not cited properly in the report.	Project report shows signs of systematic documentation. Report is followed standard format and contains only a few references. Organization of the report is good. Most references are cited properly.
			(0 - 7 Marks)	(8 - 12 Marks)	(13 - 19 Marks)

**Phase - I Project Report Marks: 20**

---

SEMESTER VII

---

---

MINOR



COURSE CODE	COURSE NAME	CATEGORY	L	T	P	CREDITS
22MEMR708	MINI PROJECT	P	3	1	0	4

Preamble: Mini Project Phase I: A Project topic must be selected either from research literature or the students themselves may propose suitable topics in consultation with their guides. The object of Project Work I is to enable the student to take up investigative study in the broad field of Mechanical Engineering, either fully theoretical/practical or involving both theoretical and practical work to be assigned by the Department on a group of three/four students, under the guidance of a Supervisor. This is expected to provide a good initiation for the student(s) in R&D work. The assignment to normally include:

- ◆ Survey and study of published literature on the assigned topic;
- ◆ Preparing an Action Plan for conducting the investigation, including team work;
- ◆ Working out a preliminary Approach to the Problem relating to the assigned topic;
- ◆ Block level design documentation
- ◆ Conducting preliminary Analysis/ Modelling/ Simulation/ Experiment/ Design/ Feasibility;
- ◆ Preparing a Written Report on the Study conducted for presentation to the Department;

CO1	Identify and synthesize problems and propose solutions to them.
CO2	Prepare work plan and liaison with the team in completing as per schedule.
CO3	Validate the above solutions by theoretical calculations and through experimental
CO4	Write technical reports and develop proper communication skills.
CO5	Present the data and defend ideas.

Mapping of course outcomes with program outcomes

	PO1	PO2	PO3	PO4	PO5	PO6	PO7	PO8	PO9	PO10	PO11	PO12
CO1	3	3	3	3					3	3		2
CO2	3			3				3	3	3	3	
CO3	3	3	3	3	3					3		
CO4					3			3	3	3		1
CO5	3	3	3	3				3		3	3	1

\*1-slight/low mapping, 2- moderate/medium mapping, 3-substantial/high mapping

#### Assessment Pattern

The End Semester Evaluation (ESE) will be conducted as an internal evaluation based on the

product, the report and a viva- voce examination, conducted by a 3-member committee appointed by Head of the Department comprising HoD or a senior faculty member, academic coordinator for that program and project guide/coordinator. The Committee will be evaluating the level of completion and demonstration of functionality/specifications, presentation, oral examination, working knowledge and involvement.

The Continuous Internal Evaluation (CIE) is conducted by evaluating the progress of the mini project through minimum of TWO reviews. At the time of the 1<sup>st</sup> review, students are supposed to propose a new system/design/idea, after completing a thorough literature study of the existing systems under their chosen area. In the 2<sup>nd</sup> review students are expected to highlight the implementation details of the proposed solution. The review committee should assess the extent to which the implementation reflects the proposed design. A well coded, assembled and completely functional product is the expected output at this stage. The final CIE mark is the average of 1<sup>st</sup> and 2<sup>nd</sup> review marks.

A zeroth review may be conducted before the beginning of the project to give a chance for the students to present their area of interest or problem domain or conduct open brain storming sessions for innovative ideas. Zeroth review will not be a part of the CIE evaluation process.

#### Marks Distribution

Total Marks	CIE	ESE
150	75	75

#### Continuous Internal Evaluation Pattern:

Attendance : 10 marks  
Marks awarded by Guide : 15 marks  
Project Report : 10 marks  
Evaluation by the Committee : 40 Marks

End Semester Examination Pattern: The following guidelines should be followed regarding award of marks.

- (a) Demonstration : 50 Marks
- (b) Project report : 10 Marks
- (d) Viva voce : 15marks

#### Course Plan

In this course, each group consisting of three/four members is expected to design and develop a moderately complex software/hardware system with practical applications. This should be a working model. The basic concept of product design may be taken into consideration.

Students should identify a topic of interest in consultation with Faculty-in-charge of miniproject/Advisor. Review the literature and gather information pertaining to the chosen topic. State the objectives and develop a methodology to achieve the objectives. Carryout the design/fabrication or develop codes/programs to achieve the objectives. Demonstrate the novelty of the project through the results and outputs. The progress of the mini project is evaluated based on a minimum of two reviews.

The review committee may be constituted by the Head of the Department. A project report is required at the end of the semester. The product has to be demonstrated for its full design specifications. Innovative design concepts, reliability considerations, aesthetics/ergonomic aspects taken care of in the project shall be given due weigh

---

# SEMESTER VII

---

## HONOURS

---

COURSE CODE	COURSE NAME	CATEGORY	L	T	P	CREDITS
22MEHR709.1	ADVANCED THEORY OF VIBRATIONS	HR	3	1	0	4

Preamble:

- To understand the principles of vibration theory.
- To introduce techniques for solving vibration problems.
- To enable development of mathematical model for engineering problems in vibrations.

Prerequisite: MET 304 Dynamics and Design of Machinery

Course Outcomes: After the completion of the course the student will be able to

CO 1	Analyse the single degree of freedom vibration system with and without damping
CO 2	Analyse forced harmonic vibration and two degree of freedom system
CO 3	Analyse the multi degree of freedom system and the Eigen value problem
CO 4	Solve vibration of continuous systems and transient vibrations
CO 5	Solve the numerical methods used in vibration analysis

Mapping of course outcomes with program outcomes

	PO 1	PO 2	PO 3	PO 4	PO 5	PO 6	PO 7	PO 8	PO 9	PO 10	PO 11	PO 12
CO 1	3	3	3									
CO 2	3	3	3									
CO 3	3	3	3									
CO 4	3	3	3									
CO 5	3	3	3									

Assessment Pattern

Bloom's Category	Continuous Assessment Tests		End Semester Examination
	1	2	
Remember			
Understand	10	10	30
Apply	40	40	70
Analyse			
Evaluate			
Create			

### Mark distribution

Total Marks	CIE	ESE	ESE Duration
150	50	100	3 hours

### Continuous Internal Evaluation Pattern:

Attendance	: 10 marks
Continuous Assessment Test (2 numbers)	: 25 marks
Assignment/Quiz/Course project	: 15 marks

End Semester Examination Pattern: There will be two parts; Part A and Part B. Part A contain 10 questions with 2 questions from each module, having 3 marks for each question. Students should answer all questions. Part B contains 2 questions from each module of which student should answer any one. Each question can have maximum 2 sub-divisions and carry 14 marks.

### Course Level Assessment Questions

#### Course Outcome 1 (CO1):

1. Explain about different types of vibrating mechanisms.
2. Describe Energy method and Rayleigh method.
3. Explain the different damping mechanisms.

#### Course Outcome 2 (CO2)

1. Describe about the magnification factor and transmissibility.
2. What is normal mode vibration and coordinate coupling.
3. Explain the working of seismometer and accelerometer.

#### Course Outcome 3(CO3):

1. Describe about Dynamic vibration absorbers and Vibration dampers
2. Explain the mode shape and Modal analysis.
3. What is Eigen value and Eigen vector.

Course Outcome 4 (CO4):

1. Discuss about the vibrating strings and longitudinal vibration of rods.
2. Explain the Torsional vibration of rods
3. Explain the Transient vibrations

Course Outcome 5 (CO5):

1. Explain Matrix Iteration and Stodola method– Dunkerley's method
2. Differentiate between Rayleigh method and Rayleigh –Ritz method
3. What is Holzer procedure for vibration analysis

Model Question Paper

SEVENTH SEMEESTER B. TECH DEGREE  
EXAMINATIONN Course Code: MET 475  
Course Name: AADVANCED THEORY OF VIBRATIONS

Max. Marks: 100

Duration: 3 Hours

PART – A

(ANSWER ALL QUESTIONS, EACH QUESTION CARRIES 3 MARKS)

1. Distinguish between longitudinal, transverse and torsional vibrations?
2. What are beats?
3. Explain the working of a vibrometer?
4. How does the forcetransmitted to the base change as the speed of the machine increases?
5. What is orthogonality of modes?
6. What are influence coefficients?
7. What is the Duhamel Integral? What is its use?
8. State the boundary conditions at the end of a string.
9. What is the basic principle used in Holzer's method?
10. Write short notes on n Rayleigh Ritz Method.

PART – B

(ANSWER ONE FULL QUESTION FROM EACH MODULE)

MODULE – 1

11. A machine of mass 18kg is supported on springs of total stiffness 12N/mm and dashpot of 0.2Ns/m damping. The system is initially at rest and a velocity of 120mm/s is imparted to the machine. Determine the displacement and velocity of machine as a function of time?

(14 marks)

12. A circular cylinder as shown below, has a mass 6kg and radius 20cm, which is joined to the fixture by a spring having stiffness 5000N/m. It is free to roll on the horizontal surface without slipping. Find the natural frequency of the system?

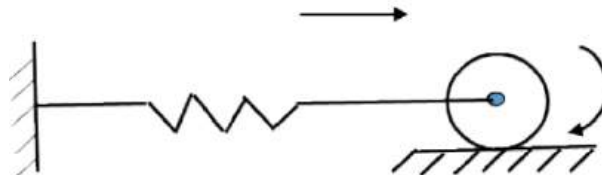

(14 marks)



### Module 2

13. A machine component having a mass of 3kg vibrates in a viscous medium. If a harmonic force 40N is applied on the system causes a resonant amplitude of 15mm with a period of 0.25second, find the damping coefficient? Find the increase in the amplitude of the forced when the damper is removed, if the frequency of exciting force is changed to 4 Hz?  
(14 marks)
14. Design Derive the general equation for damped free vibration of a single degree of freedom system? Arrive at the equation of under damped system?  
(14 marks)

### Module 3

15. Find out the natural frequency of the system given below using influence coefficient method?

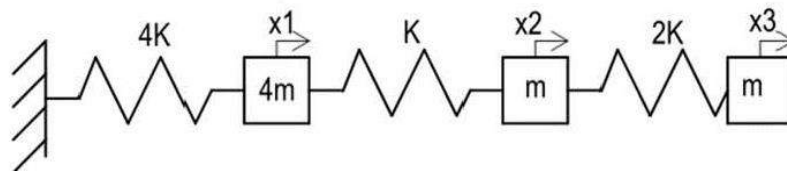

(14 marks)

16. A reciprocating machine has a weight of 250N which runs at a constant speed of 500rpm. It was found after final installation that the forcing frequency is very close to the natural frequency of the system. Find the mass of the dynamic absorber to be added to the system, the nearest natural frequency of the system should be at least 25 percent from the impressed frequency?  
(14 marks)

### Module 4

17. Derive an expression for the torsional vibration in case of a shaft having torque T acting at both the ends?  
(14 marks)
18. a) Derive the impulse response function of a damped free vibration system? (7 marks)  
b) A trailer being pulled at a high speed, hits a h cm high curb. Considering the trailer to be single degree of freedom system, analyse the system for the response.  
(7 marks)

### Module 5

19. Using Stodola technique determine the first natural frequency of the following system?

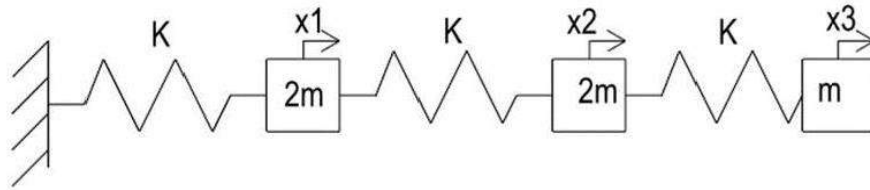

(14 marks)

20. Find out the natural frequency of the system given below using matrix iteration method?

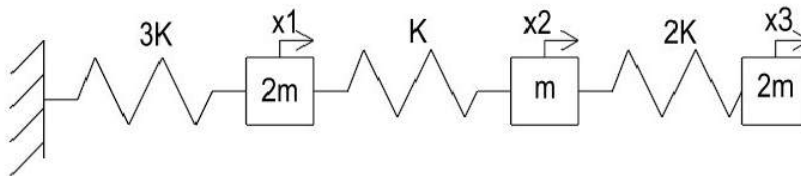

(14 marks)

### Syllabus

#### Module 1

Introduction to mechanical vibrations- Definitions -Types of vibrations- Degrees of freedom- Oscillatory motion – Periodic motion- Beat phenomenon

Free vibration of single degree of freedom systems with damping - Natural frequency using Energy method- Rayleigh method- Newton's method

Free vibration of single degree of freedom systems with damping- Viscous damping- Logarithmic decrement-

Coulomb damping- - Structural damping

#### Module 2

Forced harmonic vibration- Magnification Factor-Transmissibility-Vibration Isolation-Base Excitation-Rotating unbalance- whirling of shafts- Resonance

Vibration measuring instruments- Seismometer-Accelerometer

Two degree of freedom systems- Generalized co-ordinates- Normal mode vibration-Principal co-ordinates-Coordinate coupling.

#### Module 3

Dynamic vibration absorbers- Vibration dampers- Numerical problems

Multi degree of freedom systems- Matrix formulation- Influence Coefficients-Flexibility Matrix-Stiffness matrix

Eigen Value problem: Eigen value and Eigen Vectors-Natural Frequency- mode shape - Orthogonality of normal modes-Modal analysis

#### Module 4

Vibration of continuous systems-Vibrating strings- Longitudinal vibration of rods—Torsional vibration of rods

Transient vibrations- Impulse excitation- Convolution integral,Response to Arbitrary Loading.

#### Module 5

Numerical methods - Matrix Iteration – Stodola – Dunkerley’s method - Rayleigh method – Rayleigh –Ritz method -Holzer procedure

#### Text Books

1. A. G. Ambekar, “Mechanical Vibrations and Noise Engineering, PHI, New Delhi
2. V.P. Singh “Mechanical Vibrations” DhanpatRai& Co (Pvt) Ltd.

#### Reference Books

1. Thomson W.T , Theory of Vibration with Applications., PHI, New Delhi
2. Rao V and J Srinivas, Mechanical Vibrations, PHI, New Delhi
3. S.S Rao, Mechanical Vibrations, Pearson Education India

## Course Contents and Lecture Schedule

No	Topic	No. of Lectures
1	Module 1	
1.1	Introduction to mechanical vibrations- Definitions -Types of vibrations- Degrees of freedom- Oscillatory motion – Periodic motion- Beat phenomenon	3
1.2	Free vibration of single degree of freedom (DOF) systems with damping - Natural frequency using Energy method- Rayleigh method- Newton’s method	3
1.3	Free vibration of single degree of freedom (DOF) systems with damping- Viscous damping- Logarithmic decrement- Coulomb damping- - Structural damping	3
2	Module 2	
2.1	Forced harmonic vibration- Magnification Factor- Transmissibility-Vibration Isolation-Base Excitation-Rotating unbalance- whirling of shafts- Resonance	4
2.2	Vibration measuring instruments- Seismometer-Accelerometer	2
2.3	Two degree of freedom systems- Generalized co-ordinates- Normal mode vibration-Principal co-ordinates-Coordinate coupling.	4
3	Module 3	
3.1	Dynamic vibration absorbers- Vibration dampers- Numerical problems	2
3.2	Multi degree of freedom systems- Matrix formulation- Influence Coefficients-Flexibility Matrix-Stiffness matrix	4
3.3	Eigen Value problem: Eigen value and Eigen Vectors-Natural Frequency- mode shape -Modal analysis	4
4	Module 4	
4.1	Vibration of continuous systems-Vibrating strings- Longitudinal vibration of rods—Torsional vibration of rods	4
4.2	Transient vibrations- Impulse excitation- Convolution integral.	4
5	Module 5	
5.1	Numerical methods - Matrix Iteration – Stodola – Dunkerley’s method -	4
5.2	Rayleigh method – Rayleigh –Ritz method -Holzer procedure	4

COURSE CODE	COURSE NAME	CATEGORY	L	T	P	CREDITS
22MEHR709.2	COMPUTATIONAL METHODS IN FLUID FLOW & HEAT TRANSFER	HR	3	1	0	4

Preamble: COMPUTATIONAL METHODS IN FLUID FLOW & HEAT TRANSFER focuses on basic concept and principles of numerically solving governing equations for fluid flow and heat transfer problems.

Prerequisite: MET203 Mechanics of Fluids, MET302 Heat and Mass Transfer

Course Outcomes: After the completion of the course the student will be able to

CO 1	Explain physical and mathematical classifications partial differential equations, discretization, Steady one-dimensional conduction in Cartesian and cylindrical coordinates,,
CO 2	Analyse One-, two, and three-dimensional steady state and transient heat conduction problems in Cartesian and cylindrical coordinates
CO 3	Explain Explicit, implicit, Crank-Nicholson and ADIschemes,; consistency, stability and convergence.
CO 4	Analyse finite volume method for diffusion and convection

Mapping of course outcomes with program outcomes

	PO 1	PO 2	PO 3	PO 4	PO 5	PO 6	PO 7	PO 8	PO 9	PO 10	PO 11	PO 12
CO 1	✓	✓	✓									
CO 2	✓	✓	✓									
CO 3	✓	✓	✓									
CO 4	✓	✓	✓									

Assessment Pattern

Bloom's Category	Continuous Assessment Tests		End Semester Examination
	1	2	
Remember	10	10	20
Understand	20	20	40
Apply	10	10	20
Analyse	10	10	20
Evaluate			
Create			

### Mark distribution

Total Marks	CIE	ESE	ESE Duration
150	50	100	3 hours

#### Continuous Internal Evaluation Pattern:

Attendance	: 10 marks
Continuous Assessment Test (2 numbers)	: 25 marks
Assignment/Quiz/Course project	: 15 marks

End Semester Examination Pattern: There will be two parts; Part A and Part B. Part A contain 10 questions with 2 questions from each module, having 3 marks for each question. Students should answer all questions. Part B contains 2 questions from each module of which student should answer any one. Each question can have maximum 2 sub-divisions and carry 14 marks.

#### Course Level Assessment Questions

##### Course Outcome 1 (CO1):

1. Explain the concept of discretization.
2. Explain the term “ Rate of Convergence”.

##### Course Outcome 2 (CO2)

1. Differentiate between Dirichlet and Newmann Boundary conditions.
2. Explain how discretization of irregular boundaries are done ?

##### Course Outcome 3(CO3):

1. Explain the significance of ADI scheme
2. Give the stability criterion of Crank Nicholson Scheme.

##### Course Outcome 4 (CO4):

1. Explain the reason for using finite volume method for convection and diffusion problems?
2. Differentiate between Hybrid and Upwind Schemes.

Model Question Paper

SEVENTH SEMESTER B.TECH DEGREE EXAMINATION

Course Code: MET497

Course Name: COMPUTATIONAL METHODS IN FLUID FLOW & HEAT  
TRANSFER

Max. Marks: 100

Duration: 3 Hours

PART – A

(ANSWER ALL QUESTIONS, EACH QUESTION CARRIES 3 MARKS)

1. What are the various errors encountered in the solution by computational methods?
2. Describe the Tridiagonal matrix algorithm (TDMA)
3. Explain the significance of line by line method of solutions
4. Give two examples of Dirichlet boundary conditions
5. Distinguish between Explicit and Implicit schemes, compare the advantages and disadvantages for each.
6. Write Crank-Nicolson FDE for  $\frac{\partial u}{\partial t} = \alpha \frac{\partial^2 u}{\partial x^2}$
7. Write a typical convection and diffusion equation in conservative form.
8. What is the benefit of conservative form of equations?
9. Differentiate between SIMPLE and SIMPLER algorithms
10. Write short notes on QUICK scheme

PART – B

(ANSWER ONE FULL QUESTION FROM EACH MODULE)

MODULE – 1

11. a) What is under relaxation? Give one formula each for PSOR and LSOR. (7 Marks)  
b) Why stability is to be ensured for numerical schemes? How is it done? (7 marks)

OR

12. With the help of suitable examples explain Taylor's series approach and polynomial fitting approach (14 marks)

MODULE – 2

13. a) Explain formation of discretized equations for regular and irregular boundaries with suitable examples (14 marks)

OR

14. Explain solution procedure for two dimensional steady state heat conduction problems (14 marks)

MODULE – 3

15. a) Write and explain the ADI formulation for the PDE  $\frac{\partial u}{\partial t} = \alpha \left( \frac{\partial^2 u}{\partial x^2} + \frac{\partial^2 u}{\partial y^2} \right)$  (9 marks)

- b) Write Crank-Nicolson FDE for  $\frac{\partial u}{\partial t} = \alpha \frac{\partial^2 u}{\partial x^2}$  (5 marks)

OR

16. a) Write the ADI formulation for the PDE  $\frac{\partial^2 u}{\partial x^2} + \frac{\partial^2 u}{\partial y^2} = 0$  (6 marks)

- b) Explain the stability criterion of ADI and Crank Nicolson Schemes. (8 marks)

MODULE – 4

17. Discuss advantages and limitations of the following with respect to convection and diffusion equation

- i) Upwind scheme
- ii) Hybrid scheme
- iii) Power-Law scheme (14 Marks)

OR

18. a) Write a typical convection and diffusion equation in conservative form. (7 marks)
- b) Explain the concept of false diffusion (7 marks)

MODULE – 5

19. a) What is the main difficulty in solving momentum equations (4 marks)
- b) How the pressure correction equation is formulated for SIMPLE procedure

(10 Marks)



OR

20. a) Explain the sequence of operations in the SIMPLE procedure with a flowchart  
(7 marks)

b) Explain the significance of SIMPLEC scheme using example (7 marks)

### Syllabus

#### Module 1

Experimental, theoretical and numerical methods of predictions, physical and mathematical classifications partial differential equations; computational economy; numerical stability; validation of numerical results; round-off-error and accuracy of numerical results; iterative convergence, condition for convergence, rate of convergence; under and over relaxations, termination of iteration; tridiagonal matrix algorithm; discretization, converting derivatives to their finite difference forms, Taylor's series approach, polynomial fitting approach; discretization error.

#### Module 2

Steady one-dimensional conduction in Cartesian and cylindrical coordinates; handling of boundary conditions; two dimensional steady state conduction problems in Cartesian and cylindrical coordinates, point-by-point and line-by-line method of solution, dealing with Dirichlet, Neumann, and bins type boundary conditions, formation of discretized equations for regular and irregular boundaries and interfaces.

#### Module 3

One-, two, and three-dimensional transient heat conduction problems in Cartesian and cylindrical coordinates, explicit, implicit, Crank Nicholson and ADI schemes. Stability criterion of these schemes, conservation form and conservative property of partial differential and finite difference equations

#### Module 4

Finite volume method for diffusion and convection-diffusion problems, steady one dimensional convection and diffusion; upwind, hybrid and power-law schemes, discretization of equation for two dimension, false diffusion,

#### Module 5

SIMPLE, SIMPLER, SIMPLEC and QUICK schemes, solution algorithms for pressure velocity coupling in steady flows; numerical marching techniques, two dimensional parabolic flows with heat transfer.

### Text Books

1. Anderson, D. A, Tannehill, J. C., and R. H. Pletcher, R. H., Computational Fluid Mechanics and Heat Transfer, Second Edition, Taylor & Francis,1995.

### Reference Books

1. T.J. Chung, Computational Fluid dynamics, Cambridge University Press, South Asian Edition, 2003.
2. Muraleedhar, K. and T. Sundararaja, T., Computational Fluid Flow and Heat Transfer, Second Edition, Narosa Publishing House, 2003.
3. Patankar, S. V., Numerical Heat Transfer and Fluid Flow, Hemisphere, 1980.
4. Versteeg, H. K. and W. Malalasekera, An Introduction to Computational Fluid Dynamics: The Finite Volume Method, Addison Wesley–Longman,1995.
5. Hornbeck, R. W., Numerical Marching Techniques for Fluid Flows with Heat Transfer, NASA, SP – 297, 1973.

### Course Contents and Lecture Schedule

No	Topic	No. of Lectures
1.1	Experimental, theoretical and numerical methods of predictions, physical and mathematical classifications partial differential equations; computational economy;	4
1.2	Validation of numerical results; round-off-error and accuracy of numerical results; iterative convergence, condition for convergence, rate of convergence; under and over relaxations,	3
1.3	Termination of iteration; tridiagonal matrix algorithm; discretization, converting derivatives to their finite difference forms, Taylor's series approach, polynomial fitting approach; discretization error.	3
2.1	Steady one-dimensional conduction in Cartesian and cylindrical coordinates; handling of boundary conditions; two dimensional steady state conduction problems in Cartesian and cylindrical coordinates,	3
2.2	Point-by-point and line-by-line method of solution, dealing with Dirichlet, Neumann, and bins type boundary conditions	2
2.3	Formation of discretized equations for regular and irregular boundaries and interfaces.	2
3.1	One-, two, and three-dimensional transient heat conduction problems in Cartesian and cylindrical coordinates , explicit, implicit, Crank Nicholson and ADI schemes	4

3.2	Stability criterion of these schemes, conservation form and conservative property of partial differential and finite difference equations	3
4.1	Finite volume method for diffusion and convection–diffusion problems, steady one dimensional convection and diffusion;	3
4.2	Upwind, hybrid and power-law schemes, discretization of equation for two dimension, false diffusion,	3
5.1	SIMPLE, SIMPLER, SIMPLEC and QUICK schemes, solution algorithms for pressure velocity coupling in steady flows;	3
5.2	Numerical marching techniques, two dimensional parabolic flows with heat transfer.	2

COURSE CODE	COURSE NAME	CATEGORY	L	T	P	CREDITS
22MEHR709.3	PRECISION MACHINING	HR	3	1	0	4

Preamble: This course is conceived to help students understand design and process issues associated with precision machining. The course introduces a few precision machining processes as well.

Prerequisite: Nil

Course Outcomes: After the completion of the course the student will be able to:

CO 1	Contrast basic premises of normal machining and precision machining
CO 2	Relate consideration of error and sources of error and role of kinematic design in establishing precision.
CO 3	Explain various sensors and AE based monitoring in precision machining environment
CO 4	Outline the basics of process planning for precision machining
CO 5	Explain various precision machining processes.

Mapping of course outcomes with program outcomes:

	PO 1	PO 2	PO 3	PO 4	PO 5	PO 6	PO 7	PO 8	PO 9	PO 10	PO 11	PO 12
CO 1	3	1	-	-	3	-	1	-	2	1	1	1
CO 2	3	1	-	-	3	-	1	-	2	1	1	1
CO 3	3	1	-	-	3	-	1	-	2	1	1	1
CO 4	3	1	-	-	3	-	1	-	2	1	1	1
CO 5	3	1	-	-	3	-	1	-	2	1	1	1
CO 6	3	1	-	-	3	-	1	-	2	1	1	1

Assessment Pattern

Bloom's Category	Continuous Assessment Tests		End Semester Examination (marks)
	1 (marks)	2 (marks)	
Remember	20	20	40
Understand	20	20	40
Apply	10	10	20
Analyse	-	-	-
Evaluate	-	-	-
Create	-	-	-

## Mark distribution

Total Marks	CIE	ESE	ESE Duration
150	50	100	3 hours

### Continuous Internal Evaluation Pattern

Attendance : 10 marks

Continuous Assessment Test (2 numbers) : 25 marks

Assignment/Quiz/Course project : 15 marks

End Semester Examination Pattern: There will be two parts; Part A and Part B. Part A contains 10 questions with 2 questions from each module, having 3 marks for each question. Students should answer all questions. Part B contains 2 questions from each module, of which student should answer any one. Each question can have maximum 2 sub-divisions and carry 14 marks.

### Course Level Assessment Questions

#### Course Outcome 1 (CO1):

1. What is Abbe's principle? List an instrument each which (a) obeys Abbe's principle (b) disobeys Abbe's principle.
2. List down various methods for testing roundness. Explain precision spindle method for checking roundness with a suitable diagram.
3. With the help of a neat diagram, explain surface roughness terminology.

#### Course Outcome 2 (CO2):

1. With the help of a suitable diagram, show the directions in which errors occur for a conventional machine tool.
2. What is an error budget? How does an error budget flow chart help in generating it?
3. Describe thermal effects in precision machining.

#### Course Outcome 3 (CO3):

1. Explain AE based topographical mapping of grinding wheels.
2. Describe AE based monitoring of face milling.
3. Explain fast AE RMS analysis for wheel condition monitoring.

Course Outcome 4 (CO4):

1. Define capability ratio.
2. Discuss the basics of process planning in precision machining process?
3. Illustrate with an example the application of capability ratio in process planning.

Course Outcome 5 (CO5):

1. Discuss typical fly cutting diamond machine configurations.
2. Discuss tool-workpiece configurations for conical- circumferential milling.
3. Discuss the tool geometry of a typical single point diamond tool.

MET499 PRECISION MACHINING

Max. Marks: 100

Duration: 3 hours

Part–A

Answer all questions. Each question carries 3 marks

1. Enumerate critical elements in precision manufacturing.
2. Clearly distinguish the terms accuracy, precision and resolution.
3. Distinguish between kinematic design and elastically averaged design.
4. What do you understand by macroscale and microscale structural compliance?
5. Which are the basic sensor types used in precision manufacturing set ups?
6. Tabulate various forms of energy converted by sensors.
7. Define process capability.
8. What are the factors that affect precision during machining?
9. Differentiate between fixed abrasive process and loose abrasive process.
10. Draw a schematic and hence outline a nano-grinding process.

Part–B

Answer one full question from each module.

Module I

11. Differentiate normal machining, precision machining and ultra-precision machining with examples (14 marks)

OR

12. Describe various “competitive drivers” of precision manufacturing. (14 marks)

Module II

13. What do you understand by microscale and macroscale structural compliance. Explain. (14 marks)

OR

14. With the help of a neat diagram explain Air bearing grinding spindle. (14 marks)

Module III

15. Explain requirements for sensor technology for precision machining. (14 marks)

OR

16. Describe an optical system for monitoring of grinding wheel topography. (14 marks)

#### Module IV

17. Describe how process capability can be used as a planning metric for transition from one process stage to another. (14 marks)

OR

18. Discuss four levels of integration between the tasks of design, manufacturing and finishing. (14 marks)

#### Module V

19. With the help of a diagram explain CMP process. (14 marks)

OR

20. Explain the process of diamond turning with suitable diagrams. (14 marks)

### Syllabus

#### Module 1

Introduction to precision machining: Competitive drivers for precision machining. Definition of terms- accuracy, precision and resolution. Metrology and measurement- Abbe's principle. Measurement of dimension and angle- measurement of form- straightness, flatness and roundness. Measurement of surface roughness.

#### Module 2

Sources of error in precision machining: Mechanical errors- errors due to machine elements, thermal errors, Error due to compliance and vibration. Error budget- error budget flow chart- (elementary idea only). Role of kinematic design in precision. Principles of design and utilisation of bearings-aerostatic bearings.

#### Module 3

Sensors in precision machining: Classification of basic sensor types- overview of sensors in manufacturing- applications- AE based monitoring of grinding wheel dressing- fast AE RMS analysis of wheel condition monitoring (description only). Topographical mapping of grinding wheel. AE based monitoring of face milling.



## Module 4

Process planning for precision machining: process planning basics-factors which influence precision-process capability-relationship between process variability and product specification- process capability as a planning metric.

## Module 5

Precision machining processes: Diamond turning and milling, fly cutting diamond machine configuration- features of diamond machine tool design- applications. Configuration for conical circumferential milling- applications. Typical single point diamond tool geometry. Abrasive processes-fixed and loose. Nano grinding-Chemical mechanical Planarization (CMP)- precision manufacturing applications.

### Text Books and References

1. David Dornfeld, Dae-Eun Lee, Precision Manufacturing, Springer, 2008
2. V.C. Venkatesh, Sudin Izman, Precision Engineering, Tata McGraw- Hill, 2007
3. Michael N. Morgan, Andrew Shaw, Otar Mgaloblishvili, Precision Machining VI, Transtech publications Ltd, Switzerland, 2012

### Course Contents and Lecture Schedule

No.	Topic	No. of Lectures
1.1	Introduction to precision machining.	1
1.2	Philosophy of precision machine design	1
1.3	Competitive drivers for precision machining	2
1.4	Definition of terms- accuracy, precision and resolution	1
1.5	Metrology and measurement – Abbe's principle	1
1.6	Measurement of dimension and angle	1
1.7	Measurement of form- straightness, flatness and roundness	1
1.8	Measurement of surface roughness	1
2.1	Sources of error in precision machining	2
2.2	Mechanical errors – errors due to machine elements, thermal errors	2
2.3	Errors due to compliance and vibration	1
2.4	Error budget	1
2.5	Error budget flow chart	1
2.6	Role of kinematic design in precision	1
2.7	Principles of design and utilisation of bearings – Aerostatic bearings	1
3.1	Sensors in Precision Machining- classification	2
3.2	Overview of sensors and applications	1
3.3	AE based monitoring of grinding wheel dressing	1
3.4	Description of Fast AE RMS analysis of wheel condition monitoring	1
3.5	Topographical mapping of grinding wheel	1

3.6	AE based monitoring of face milling	1
4.1	Process planning for precision machining	2
4.2	Process planning basics	1
4.3	Factors influencing precision.	1
4.4	Process capability	2
4.5	Relationship between process variability and product specification	1
4.6	Process capability as a planning metric	1
5.1	Precision machining Processes – Diamond turning and milling	1
5.2	Fly cutting diamond machine configuration	1
5.3	Features of diamond machine tool design-applications	1
5.4	Configuration for conical circumferential milling- applications	1
5.5	Typical single point diamond tool geometry	1
5.6	Abrasive processes- fixed and loose	1
5.7	Nano grinding	1
5.8	Chemical Mechanical Planarization	1
5.9	Precision manufacturing applications	1

---

# SEMESTER VIII

---

COURSE CODE	COURSE NAME	CATEGORY	L	T	P	CREDITS
22MET801	MECHATRONICS	ES	2	1	0	3

Preamble: This course provides the mechanical systems used in Mechatronics and the Integration of mechanical, electronics, control and computer engineering in the design of mechatronics systems.

Prerequisite: NIL

Course Outcomes: After the completion of the course the student will be able to

CO Nos	Course Outcomes	Level of learning domain
CO 1	Explain the sensors and actuators used in mechatronics	2
CO 2	Design hydraulic and pneumatic circuits for automation.	6
CO 3	Explain the manufacturing processes used in MEMS	2
CO 4	Demonstrate the various components of a CNC machine	2
CO 5	Create a PLC program	6
CO 6	Explain the robotic sensors and vision system	2

Mapping of course outcomes with program outcomes

	PO 1	PO 2	PO 3	PO 4	PO 5	PO 6	PO 7	PO 8	PO 9	PO 10	PO 11	PO 12
CO 1	3	2	2									
CO 2	3	3	3		3							
CO 3	3	1	1									
CO 4	3	1	1									
CO 5	3	3	3		3							
CO 6	3	1	1									

Assessment Pattern

Bloom's Category	Continuous Assessment Tests		End Semester Examination
	1	2	
Remember			
Understand	40	40	70
Apply			
Analyse			
Evaluate			
Create	10	10	30

### Mark distribution

Total Marks	CIE	ESE	ESE Duration
150	50	100	3 hours

#### Continuous Internal Evaluation Pattern:

Attendance	: 10 marks
Continuous Assessment Test (2 numbers)	: 25 marks
Assignment/Quiz/Course project	: 15 marks

End Semester Examination Pattern: There will be two parts; Part A and Part B. Part A contain 10 questions with 2 questions from each module, having 3 marks for each question. Students should answer all questions. Part B contains 2 questions from each module of which student should answer any one. Each question can have maximum 2 sub-divisions and carry 14 marks.

#### Course Level Assessment Questions

##### Course Outcome 1 (CO1):

1. Which type of sensor can be used for determining angular movement of a shaft?
2. What is the significance of grey scale in absolute encoders?
3. Which type of actuator can be used for a mechanical system?

##### Course Outcome 2 (CO2)

1. Explain the basic structure of a simple hydraulic circuit?
2. Explain the basic structure of a simple pneumatic circuit?
3. Design a hydraulic circuit for two hand operation of a hydraulic press?
4. Design a pneumatic circuit for the sequencing operation A+B+A-B-.

##### Course Outcome 3(CO3):

1. Explain the LIGA process.
2. Explain the MEMS based gyroscope?
3. Explain the deposition-based MEMS manufacturing technique?

##### Course Outcome 4 (CO4):

1. Explain the working of ant frictional guideways?
2. Demonstrate suitable methods to achieve antifriction feed drive system?
3. Demonstrate suitable non-contact type measuring system that can be used in CNC?

Course Outcome 5 (CO5):

1. Discuss About various type of range finders used in robotics?
2. Discuss about various image accusation techniques used in robotics?
3. Discuss various image processing techniques used in robotics?

Model Question Paper

MECHATRONICS - MET402

Max. Marks : 100

Duration : 3 Hours

PART – A

Answer all questions, each question carries 3 marks

1. Explain the significance of grey codes in an absolute optical encoder?
2. Explain cushioning in pneumatic actuator?
3. Explain with a neat sketch working of a poppet valve.
4. What is meant by high aspect ratio machining? List any 2 methods of manufacturing used in it.
5. Differentiate between hydrostatic and hydro dynamic bearing used in CNC machines.
6. What is meant by stick slip phenomena in a frictional guideway?
7. Explain the XOR logic using suitable ladder diagram and truth table?
8. Explain the ladder diagram for a delay on timer circuit?
9. Differentiate between CCD and CID camera used in robots?
10. Discuss the functioning of a tactile sensors?

PART -B

Answer one full question from each module.

MODULE – 1

11. List and explain in detail the static and dynamic characteristics of a sensor (10 marks)

OR

12. a) Write a note on rotary actuators. (3 marks)  
b) Explain with a suitable diagram various component of a pneumatic system. (7 marks)

MODULE – 2

13. Develop a hydraulic circuit for the sequencing operation A+B+A-B-? (10 marks)

OR

14. Explain the working of MMS based accelerometer with a neat sketch? (8 marks)

MODULE – 3

15. a) What is meant by preloading? Explain in detail about preloading methods used in a recirculating ball screw (6 marks)  
b) Explain various load acting on a CNC machine structure (4 marks)

OR

16. Develop a mathematical model for a general fluid system (10 marks)

MODULE – 4

17. Two motors are to be controlled in a sequence. The second motor starts 30 seconds after the starting of first motor by a push switch. Develop a PLC ladder diagram for the following cases and describe the circuit.

Case (A): Only one motor operates at a time.

Case (B): Both the motor gets off together after 50 seconds.3DP (10 marks)

OR

18 Explain the working of an automobile engine management system using suitable diagrams. Also explain its advantages over conventional automobile system (10 marks)

MODULE – 5

19 a) what is meant by image accusation? Illustrate the working of Charge Coupled Device for machine vision applications. (10 marks)

OR

- 20 a) Explain the histogram processing technique in image processing. (6 marks)  
b) What is meant by thresholding in image processing? (4 marks)

## SYLLABUS

### Module 1

Introduction to Mechatronics: Structure of Mechatronics system. Sensors - Characteristics - Temperature, flow, pressure sensors. Displacement, position and proximity sensing by magnetic, optical, ultrasonic, inductive, capacitive and eddy current methods. Encoders: incremental and absolute, gray coded encoder. Resolvers and synchros. Piezoelectric sensors. Acoustic Emission sensors. Principle and types of vibration sensors. Actuators: Mechanical actuators, Electrical actuators, Hydraulic and Pneumatic actuators

### Module 2

Directional control valves, pressure control valves, process control valves. Rotary actuators. Development of simple hydraulic and pneumatic circuits using standard Symbols. Micro Electro Mechanical Systems (MEMS): Fabrication: Deposition, Lithography, Micromachining methods for MEMS, Deep Reactive Ion Etching (DRIE) and LIGA processes. Principle, fabrication and working of MEMS based pressure sensor, accelerometer and gyroscope.

### Module 3

Mechatronics in Computer Numerical Control (CNC) machines: Design of modern CNC machines - Mechatronics elements - Machine structure: guide ways, drives. Bearings: anti-friction bearings, hydrostatic bearing and hydrodynamic bearing. Re-circulating ball screws, pre-loading methods. Re-circulating roller screws. Measuring system for NC machines - direct and indirect measuring system. System modeling - Mathematical models and basic building blocks of general mechanical, electrical, fluid and thermal systems.

### Module 4

Typical elements of open and closed loop control systems. Adaptive controllers for machine tools. Programmable Logic Controllers (PLC) –Basic structure, input/ output processing. Programming: Timers, Internal Relays, Counters and Shift registers. Development of simple ladder programs for specific purposes. Case studies of Mechatronics systems: Automatic camera, bar code reader, pick and place robot, automatic car park barrier system, automobile engine management system.

### Module 5

Mechatronics in Robotics-Electrical drives: DC, AC, brushless, servo and stepper motors. Harmonic drive. Force and tactile sensors. Range finders: ultrasonic and light-based range finders. Robotic vision system - Image acquisition: Vidicon, charge coupled device (CCD) and charge injection device (CID) cameras. Image processing techniques: histogram processing: sliding, stretching, equalization and thresholding.

### Text Books

1. Bolton W., Mechatronics: Electronic Control Systems in Mechanical and Electrical Engineering, Person Education Limited, New Delhi, 2007
2. Ramachandran K. P., G. K. Vijayaraghavan, M. S. Balasundaram, Mechatronics: Integrated Mechanical Electronic Systems, Wiley India Pvt. Ltd., New Delhi, 2008.
3. Saeed B. Niku, Introduction to Robotics: Analysis, Systems, Applications, Person Education, Inc., New Delhi, 2006.



## Reference Books

1. David G. Aldatore, Michael B. Hstand, Introduction to Mechatronics and Measurement Systems, McGraw-Hill Inc., USA, 2003.
2. Gordon M. Mair, Industrial Robotics, Prentice Hall International, UK, 1998.
3. HMT, Mechatronics, Tata McGraw-Hill Publishing Company Ltd., New Delhi, 2004.
4. Vijay K. Varadan, K. J. Vinoy, S. Gopalakrishnan, Smart Material Systems and MEMS: Design and Development Methodologies, John Wiley & Sons Ltd., England, 2006.

## Course Contents and Lecture Schedule

No	Topic	No. of Lectures
<b>MODULE 1</b>		
1.1	Introduction to Mechatronics: Structure of Mechatronics system. Sensors - Characteristics	1
1.2	Temperature, flow, pressure sensors. Displacement, position and proximity sensing by magnetic, optical, ultrasonic, inductive, capacitive and eddy current methods.	2
1.3	Encoders: incremental and absolute, gray coded encoder.	1
1.4	. Resolvers and synchros. Piezoelectric sensors. Acoustic Emission sensors. Principle and types of vibration sensors.	1
1.5	Actuators: Mechanical actuators, Electrical actuators, Hydraulic and Pneumatic actuators	2
<b>MODULE 2</b>		
2.1	Directional control valves, pressure control valves, process control valves. Rotary actuators.	2
2.2	Development of simple hydraulic and pneumatic circuits using standard Symbols.	2
2.3	Micro Electro Mechanical Systems (MEMS): Fabrication: Deposition, Lithography, Micromachining methods for MEMS,	2
2.4	Deep Reactive Ion Etching (DRIE) and LIGA processes.	1
2.5	Principle, fabrication and working of MEMS based pressure sensor, accelerometer and gyroscope.	2
<b>MODULE 3</b>		
3.1	Mechatronics in Computer Numerical Control (CNC) machines: Design of modern CNC machines - Mechatronics elements - Machine structure: guide ways, drives. Bearings: anti-friction bearings, hydrostatic bearing and hydrodynamic bearing.	2
3.2	Re-circulating ball screws, pre-loading methods. Re-circulating roller screws. Measuring system for NC machines - direct and indirect measuring system.	2
3.3	System modeling - Mathematical models and basic building blocks of general mechanical & electrical system	1
3.4	Mathematical models and basic building blocks of general fluid and thermal systems	1

MODULE 4		
4.1	Typical elements of open and closed loop control systems. Adaptive controllers for machine tools. Programmable Logic Controllers (PLC) – Basic structure, input/ output processing.	2
4.2	Programming: Timers, Internal Relays, Counters and Shift registers. Development of simple ladder programs for specific purposes	2
4.3	Case studies of Mechatronics systems: Automatic camera, bar code reader, pick and place robot, automatic car park barrier system, automobile engine management system.	2
MODULE 5		
5.1	Mechatronics in Robotics-Electrical drives: DC, AC, brushless, servo and stepper motors. Harmonic drive.	2
5.2	Force and tactile sensors. Range finders: ultrasonic and light-based range finders	2
5.3	Robotic vision system - Image acquisition: Vidicon, charge coupled device (CCD) and charge injection device (CID) cameras.	2
5.4	Image processing techniques: histogram processing: sliding, stretching, equalization and thresholding.	2

COURSE CODE	COURSE NAME	CATEGORY	L	T	P	CREDITS
22MEV805	COMPREHENSIVE VIVA VOCE	V	1	0	0	1

Preamble: The objective of this Course viva is to ensure the basic knowledge of each student in the most fundamental core courses in the curriculum. The viva voce shall be conducted based on the core subjects studied from third to eighth semester. This course helps the learner to become competent in placement tests and other competitive examinations.

#### Guidelines

1. The course should be mapped with a faculty and classes shall be arranged for practicing questions based on the core courses listed in the curriculum.
2. The viva voce will be conducted by the same three member committee assigned for final project phase II evaluation. It comprises of Project coordinator, expert from Industry/research Institute and a senior faculty from a sister department.
3. The pass minimum for this course is 25.
4. The mark will be treated as internal and should be uploaded along with internal marks of other courses.
5. Comprehensive Viva should be conducted along with final project evaluation by the three member committee.

#### Mark Distribution

Total marks: 50, only CIE, minimum required to pass : 25 Marks

COURSE CODE	COURSE NAME	CATEGORY	L	T	P	CREDITS
22MEP806	PROJECT PHASE II	P	0	0	12	4

Preamble: The course ‘Project Work’ is mainly intended to evoke the innovation and invention skills in a student. The course will provide an opportunity to synthesize and apply the knowledge and analytical skills learned, to be developed as a prototype or simulation. The project extends to 2 semesters and will be evaluated in the 7th and 8th semester separately, based on the achieved objectives. One third of the project credits shall be completed in 7th semester and two third in 8th semester. It is recommended that the projects may be finalized in the thrust areas of the respective engineering stream or as interdisciplinary projects. Importance should be given to address societal problems and developing indigenous technologies.

### Course Objectives

- To apply engineering knowledge in practical problem solving.
- To foster innovation in design of products, processes or systems.
- To develop creative thinking in finding viable solutions to engineering problems.

Course Outcomes [COs]: After successful completion of the course, the students will be able to:

CO1	Model and solve real world problems by applying knowledge across domains (Cognitive knowledge level: Apply).
CO2	Develop products, processes or technologies for sustainable and socially relevant applications (Cognitive knowledge level: Apply).
CO3	Function effectively as an individual and as a leader in diverse teams and to comprehend and execute designated tasks (Cognitive knowledge level: Apply).
CO4	Plan and execute tasks utilizing available resources within timelines, following ethical and professional norms (Cognitive knowledge level: Apply).
CO5	Identify technology/research gaps and propose innovative/creative solutions (Cognitive knowledge level: Analyze).
CO6	Organize and communicate technical and scientific findings effectively in written and oral forms (Cognitive knowledge level: Apply).

### Mapping of course outcomes with program outcomes

	PO1	PO2	PO3	PO4	PO5	PO6	PO7	PO8	PO9	PO10	PO11	PO12
CO1	2	2	2	1	2	2	2	1	1	1	1	2
CO2	2	2	2		1	3	3	1	1		1	1
CO3									3	2	2	1
CO4					2			3	2	2	3	2
CO5	2	3	3	1	2							1
CO6					2			2	2	3	1	1

Abstract POs defined by National Board of Accreditation			
PO #	Broad PO	PO#	Broad PO
PO1	Engineering Knowledge	PO7	Environment and Sustainability
PO2	Problem Analysis	PO8	Ethics
PO3	Design/Development of solutions	PO9	Individual and team work
PO4	Conduct investigations of complex problems	PO0	Communication
PO5	Modern tool usage	PO11	Project Management and Finance
PO6	The Engineer and Society	PO12	Lifelong learning

## PROJECT PHASE II

### Phase 2 Targets

- In depth study of the topic assigned in the light of the report prepared under Phase - I;
- Review and finalization of the approach to the problem relating to the assigned topic.
- Preparing a detailed action plan for conducting the investigation, including teamwork.
- Detailed Analysis/ Modeling / Simulation/ Design/ Problem Solving/Experiment as needed.
- Final development of product/ process, testing, results, conclusions and future directions.
- Preparing a paper for Conference Presentation/ Publication in Journals, if possible.
- Presenting projects in Project Expos conducted by the University at the cluster level and/ or state level as well as others conducted in India and abroad.
- Filing Intellectual Property Rights (IPR) if applicable.
- Preparing a report in the standard format for being evaluated by the Department Assessment Board.
- Final project presentation and viva voce by the assessment board including the external expert.

### Evaluation Guidelines & Rubrics

Total: 150 marks (Minimum required to pass: 75 marks).

- Project progress evaluation by guide: 30 Marks.
- Two interim evaluations by the Evaluation Committee: 50 Marks (25 marks for each evaluation).
- Final evaluation by the Final Evaluation committee: 40 Marks
- Quality of the report evaluated by the evaluation committee: 30 Marks

(The evaluation committee comprises HoD or a senior faculty member, Project coordinator and project supervisor. The final evaluation committee comprises of Project coordinator, expert from Industry/research/academic Institute and a senior faculty from a sister department).

## Evaluation by the Guide

The guide/supervisor must monitor the progress being carried out by the project groups on regular basis. In case it is found that progress is unsatisfactory it should be reported to the Department Evaluation Committee for necessary action. The presence of each student in the group and their involvement in all stages of execution of the project shall be ensured by the guide. Project evaluation by the guide: 30 Marks. This mark shall be awarded to the students in his/her group by considering the following aspects:

Project Scheduling & Distribution of Work among Team members: Detailed and extensive Scheduling with timelines provided for each phase of project. Work breakdown structure well defined. (5)

Literature survey: Outstanding investigation in all aspects. (4)

Student's Diary/ Daily Log: The main purpose of writing daily diary is to cultivate the habit of documenting and to encourage the students to search for details. It develops the students' thought process and reasoning abilities. The students should record in the daily/weekly activity diary the day to day account of the observations, impressions, information gathered and suggestions given, if any. It should contain the sketches & drawings related to the observations made by the students. The daily/weekly activity diary shall be signed after every day/week by the guide. (7)

Individual Contribution: The contribution of each student at various stages. (9)

Completion of the project: The students should demonstrate the project to their respective guide. The guide shall verify the results and see that the objectives are met. (5)

**EVALUATION RUBRICS for PROJECT Phase II: Interim Evaluation - 1**

No.	Parameters	Marks	Poor	Fair	Very Good	Outstanding
2-a	Novelty of idea, and Implementation scope [CO5] [Group Evaluation]	5	The project is not addressing any useful requirement. The idea is evolved into a non-implementable one. The work presented so far is lacking any amount of original work by the team.	Some of the aspects of the proposed idea can be implemented. There is still lack of originality in the work done so far by the team. The project is a regularly done theme/topic without any freshness in terms of specifications, features, and/or improvements.	Good evidence of an implementable project. There is some evidence for the originality of the work done by the team . There is fresh specifications/features/improvements suggested by the team. The team is doing a design from fundamental principles, and there is some independent learning and engineering ingenuity.	The project has evolved into incorporating an outstandingly novel idea. Original work which is not yet reported anywhere else. Evidence for ingenious way of innovation which is also Implementable. Could be a patentable / publishable work.
			(0 – 1 Marks)	(2 – 3 Marks)	(4 Marks)	(5 Marks)
2-b	Effectiveness of task distribution among team members. [CO3] [Group Evaluation]	5	No task distribution of any kind. Members are still having no clue on what to do.	Task allocation done, but not effectively, some members do not have any idea of the tasks assigned. Some of the tasks were identified but not followed individually well.	Good evidence of task allocation being done, supported by project journal entries, identification of tasks through discussion etc. However, the task distribution seems to be skewed, and depends a few members heavily than others. Mostly the tasks are being followed by the individual members.	Excellent display of task identification and distribution backed by documentary evidence of team brainstorming, and project journal entries. All members are allocated tasks according to their capabilities, and as much as possible in an equal manner. The individual members are following the tasks in an excellent manner.
			(0 – 1 Marks)	(2 – 3 Marks)	(4 Marks)	(5 Marks)
2-c	Adherence to project schedule. [CO4] [Group Evaluation]	5	Little or no evidence of continued planning or scheduling of the project. The students did not stick to the plan what they were going to build nor plan on what materials / resources to use in the project. The students do not have any idea on the budget required even after the end of phase - I. No project journal kept or the journal.	There is some improvement in the primary plan prepared during phase I. There were some ideas on the materials /resources required, but not really thought out. The students have some idea on the finances required, but they have not formalized a budget plan. Schedules were not prepared. The project journal has no useful details on the project.	Good evidence of planning done and being followed up to a good extent after phase I. Materials were listed and thought out, but the plan wasn't followed completely. Schedules were prepared, but not detailed, and needs improvement. Project journal is presented but it is neither complete nor updated regularly.	Excellent evidence of enterprising and extensive project planning and follow-up since phase I. Continued use of project management/version control tool to track the project. Material procurement if applicable is progressing well. Tasks are updated and incorporated in the schedule. A well-kept project journal showed evidence for all the above, in addition to the interaction with the project guide.
			(0 - 1 Marks)	(2 - 3 Marks)	(4 Marks)	(5 Marks)

2-d	Interim Results. [CO6] [Group assessment]	5	There are no interim results to show.	The team showed some interim results, but they are not complete / consistent to the current stage, Some corrections are needed.	The interim results showed were good and mostly consistent/correct with respect to the current stage. There is room for improvement.	There were significant interim results presented which clearly shows the progress.
			(0 - 1 Marks)	(2 - 3 Marks)	(4 Marks)	(5 Marks)
2-e	Presentation [Individual assessment]	5	Very poor presentation and there is no interim results. The student has no idea about the project proposal.	Presentation is average, and the student has only a feeble idea about the team work.	Good presentation. Student has good idea about the team's project. The overall presentation quality is good.	Exceptionally good presentation. Student has excellent grasp of the project. The quality of presentation is outstanding.
			(0 - 1 Marks)	(2 - 3 Marks)	(4 Marks)	(5 Marks)
Phase-II Interim Evaluation - 1 Total Marks: 25						



**EVALUATION RUBRICS for PROJECT Phase II: Interim Evaluation – 2**

No	Parameters	Marks	Poor	Fair	Very Good	Outstanding
2-f	Application of engineering knowledge [CO1] [Individual Assessment]	10	The student does not show any evidence of applying engineering knowledge on the design and the methodology adopted. The student's contribution in application of engineering knowledge in the project is poor.	The student appears to apply some basic knowledge, but not able to show the design procedure and the methodologies adopted in a comprehensive manner.	The student is able to show some evidence of application of engineering knowledge in the design and development of the project to good extent.	Excellent knowledge in design procedure and its adaptation. The student is able to apply knowledge from engineering domains to the problem and develop solutions.
			(0 – 3 Marks)	(4 – 6 Marks)	(7 - 9 Marks)	(10 Marks)
2-g	Involvement of individual members [CO3] [Individual Assessment]	5	No evidence of any Individual participation in the project work.	There is evidence for some amount of individual contribution, but is limited to some of the superficial tasks.	The individual contribution is evident. The student has good amount of involvement in core activities of the project.	Evidence available for the student acting as the core technical lead and has excellent contribution to the project.
			(0 - 1 Marks)	(2 - 3 Marks)	(4 Marks)	(5 Marks)
2-h	Results and inferences upon execution [CO5] [Group Assessment]	5	None of the expected outcomes are achieved yet. The team is unable to derive any inferences on the failures/issues observed. Any kind of observations or studies are not made.	Only a few of the expected outcomes are achieved. A few inferences are made on the observed failures/issues. No further work suggested.	Many of the expected outcomes are achieved. Many observations and inferences are made, and attempts to identify the issues are done. Some suggestions are made for further work.	Most of the stated outcomes are met. Extensive studies are done and inferences drawn. Most of the failures are addressed and solutions suggested. Clear and valid suggestions made for further work.
			(0 - 1 Marks)	(2 - 3 Marks)	(4 Marks)	(5 Marks)
2-i	Documentation and presentation. [CO6] [Individual assessment]	5	The individual student has no idea on the presentation of his/her part. The presentation is of poor quality.	Presentation's overall quality needs to be improved.	The individual's presentation performance is satisfactory.	The individual's presentation is done professionally and with great clarity. The individual's performance is excellent.
			(0 - 1 Marks)	(2 - 3 Marks)	(4 Marks)	(5 Marks)

Phase-II Interim Evaluation - 2 Total Marks: 25

**EVALUATION RUBRICS for PROJECT Phase II: Final Evaluation**

No	Parameters	Marks	Poor	Fair	Very Good	Outstanding
2-j	Engineering knowledge. [CO1] [Group Assessment]	10	The team does not show any evidence of applying engineering knowledge on the design and the methodology adopted.	The team is able to show some of the design procedure and the methodologies adopted, but not in a comprehensive manner.	The team is able to show evidence of application of engineering knowledge in the design and development of the project to good extent. There is scope for improvement.	Excellent knowledge in design procedure and its adaptation. The team is able to apply knowledge from engineering domains to the problem and develop an excellent solution.
			(0 – 3 Marks)	(4 – 6 Marks)	(7 - 9 Marks)	(10 Marks)
2-k	Relevance of the project with respect to societal and/or industrial needs. [Group Assessment] [CO2]	5	The project as a whole do not have any societal / industrial relevance at all.	The project has some relevance with respect to social and/or industrial application. The team has however made not much effort to explore further and make it better.	The project is relevant to the society and/or industry. The team is mostly successful in translating the problem into an engineering specification and managed to solve much of it.	The project is exceptionally relevant to society and/or industry. The team has made outstanding contribution while solving the problem in a professional and/or ethical manner.
			(0 - 1 Marks)	(2 - 3 Marks)	(4 Marks)	(5 Marks)
2-i	Innovation / novelty / Creativity [CO5] [Group Assessment]	5	The project is not addressing any useful requirement. The idea is evolved into a non-implementable one. The work presented so far is lacking any amount of original work by the team.	Some of the aspects of the proposed idea appears to be practical. There is still lack of originality in the work done. The project is a regularly done theme/topic without any freshness in terms of specifications, features, and/or improvements.	Good evidence of an implementable project. There is some evidence for the originality of the work done by the team. There is fresh specifications/features/improvements suggested by the team. The team is doing a design from fundamental principles, and there is some independent learning and engineering ingenuity. Could be translated into a product / process if more work is done.	The project has evolved into incorporating an outstandingly novel idea. Original work which is not yet reported anywhere else. Evidence for ingenious way of innovation which is also Implementable. Could be a patentable publishable work.
			(0 - 1 Marks)	(2 - 3 Marks)	(4 Marks)	(5 Marks)
2-m	Quality of results / conclusions / solutions. [CO1] [Group Assessment]	10	None of the expected outcomes are achieved. The team is unable to derive any inferences on the failures/issues observed. Any kind of observations or studies is not made.	Only a few of the expected outcomes are achieved. A few inferences are made on the observed failures/issues. No further work suggested.	Many of the expected outcomes are achieved. Many observations and inferences are made, and attempts to identify the issues are done. Some suggestions are made for further work.	Most of the stated outcomes are met. Extensive studies are done and inferences drawn. Most of the failures are addressed and solutions suggested. Clear and valid suggestions made for further work.
			(0 – 3 Marks)	(4 – 6 Marks)	(7 - 9 Marks)	(10 Marks)

2-n	Presentation - Part I Preparation of slides. [CO6] [Group Assessment].	5	The presentation slides are shallow and in a clumsy format. It does not follow proper organization.	Presentation slides follow professional style formats to some extent. However, its organization is not very good. Language needs to be improved. All references are not cited properly, or acknowledged. Presentation slides needs to be more professional.	Presentation slides follow a good style format and there are only a few issues. Organization of the slides is good. Most of references are cited properly. The flow is good and team presentation is neatly organized. Some of the results are not clearly shown. There is room for improvement.	The presentation slides are exceptionally good. Neatly organized. All references cited properly. Diagrams/Figures, Tables and equations are properly numbered, and listed. Results/ inferences clearly highlighted and readable.
			(0 - 1 Marks)	(2 - 3 Marks)	(4 Marks)	(5 Marks)
	Presentation - Part II: Individual Communication [CO6] [Individual Assessment].	5	The student is not communicating properly. Poor response to questions.	The student is able to explain some of the content. The student requires a lot of prompts to get to the idea. There are language issues.	Good presentation/ communication by the student. The student is able to explain most of the content very well. There are however, a few areas where the student shows lack of preparation. Language is better.	Clear and concise communication exhibited by the student. The presentation is outstanding. Very confident and tackles all the questions without hesitation. Exceptional traits of communicator.
			(0 - 1 Marks)	(2 - 3 Marks)	(4 Marks)	(5 Marks)

Phase-II Final Evaluation, Marks: 40

EVALUATION RUBRICS for PROJECT Phase II: Report Evaluation

Sl. No.	Parameters	Marks	Poor	Fair	Very Good	Outstanding
2-o	Report [CO6]	30	The prepared report is shallow and not as per standard format. It does not follow proper organization. Contains mostly unacknowledged content. Lack of effort in preparation is evident. References are not cited. Unprofessional and inconsistent formatting.	Project report follows the standard format to some extent. However, its organization is not very good. Language needs to be improved. All references are not cited properly in the report. There is lack of formatting consistency.	Project report shows evidence of systematic documentation. Report is mostly following the standard style format and there are only a few issues. Organization of the report is good. Mostly consistently formatted. Most of references/sources are cited, acknowledged properly.	The report is exceptionally good. Neatly organized. All references cited properly. Diagrams/Figures, Tables and equations are properly numbered, and listed and clearly shown. Language is excellent and follows professional styles. Consistent formatting and exceptional readability.
			(0 - 11 Marks)	(12 - 18 Marks)	(19 - 28 Marks)	(29 - 30 Marks)
Phase - II Project Report Marks: 30						

---

**SEMESTER VIII**

---

**PROGRAM ELECTIVE III**

---

COURSE CODE	COURSE NAME	CATEGORY	L	T	P	CREDITS
22MEE802.1	QUALITY MANAGEMENT	PROGRAM ELECTIVE III	2	1	0	3

Preamble: This course is designed to facilitate the students to understand the concept and culture of total quality management. It empowers the students by inculcating the skills to use quality control techniques and other quality tools in solving quality-related problems and apply these principles in an industry. This course will also amalgamate their knowledge about the importance of customer satisfaction through desired quality at a competitive price.

Prerequisite: NIL

Course Outcomes: After the completion of the course the student will be able to

CO 1	To be conversant with important terms for quality management in organisations
CO 2	Have a complete theoretical and practical understanding of the contributions of Quality Gurus
CO 3	Demonstrate knowledge of the underlying principles of strategic quality management
CO 4	Identify various human dimensions of TQM
CO 5	Implement different tools and techniques in TQM
CO 6	Identify core and extended modules of ISO 9000 family of standards

Mapping of course outcomes with program outcomes

	PO 1	PO 2	PO 3	PO 4	PO 5	PO 6	PO 7	PO 8	PO 9	PO 10	PO 11	PO 12
CO 1	3					2					3	3
CO 2	2										2	2
CO 3	2	2	2						3		3	3
CO 4	3					3			3		3	3
CO 5	2	3	3	2	2				2		3	2
CO 6					2	2	1	1	2	3	3	1

Assessment Pattern

Bloom's Category	Continuous Assessment Tests		End Semester Examination (in %)
	1 (in %)	2 (in %)	
Remember	20	20	20
Understand	60	40	40
Apply	20	40	40
Analyse			
Evaluate			
Create			

### Mark distribution

Total Marks	CIE Marks	ESE Marks	ESE Duration
150	50	100	3 hours

#### Continuous Internal Evaluation Pattern:

Attendance	: 10 marks
Continuous Assessment Test (2 numbers)	: 25 marks
Assignment/Quiz/Course project	: 15 marks

End Semester Examination Pattern: There will be two parts; Part A and Part B. Part A contain 10 questions with 2 questions from each module, having 3 marks for each question. Students should answer all questions. Part B contains 2 questions from each module of which student should answer any one. Each question can have maximum 2 sub-divisions and carry 14 marks.

#### Course Level Assessment Questions

##### Course Outcome 1 (CO1):

1. Distinguish between quality control and inspection.
2. What are the TQM axioms?
3. What are the enablers of total quality?

##### Course Outcome 2 (CO2)

1. Describe the Deming approach to TQM.
2. List out Crosby's fourteen steps for quality improvement.
3. Describe Juran's quality trilogy.

##### Course Outcome 3(CO3):

1. Define strategic quality management.
2. With examples, describe the classification of quality costs.
3. Describe the concepts of Kaizen approach.

##### Course Outcome 4(CO4):

1. What is meant by employee empowerment with respect to total quality management?
2. What are self managing teams?

3. Describe the importance of leadership in TQM

Course Outcome 5 (CO5):

1. "X and R charts always go hand in hand". Elaborate.
2. What are the measures of Central tendency and dispersion?
3. Describe the principles of cause and effect diagram.

Course Outcome 6 (CO6):

1. Enumerate the benefits of ISO certification.
2. What are the benefits of quality auditing?
3. Enumerate the steps to be followed by a manufacturing organization to obtain ISO 9001 certification

Model Question Paper

EIGHTH SEMESTER B.TECH DEGREE  
EXAMINATION

Course Code: MET414

Course Name: QUALITY MANAGEMENT

Max. Marks: 100

Duration: 3 Hours

PART A

Answer ALL questions, each carries 3 marks.

1. Define the term "Quality control".
2. What are the enablers of total quality?
3. Describe the concept of Quality Function Deployment
4. What are the obstacles to achieving successful strategic quality management?
5. What is meant by employee empowerment?
6. Describe the importance of leadership in TQM
7. Describe the principles of cause and effect diagram.
8. Describe the procedure to be followed in a brain storming meeting.
9. Explain the clause in ISO 9001 associated with resource management.
10. What are the benefits of quality auditing?



PART B

(Answer one full question from each module, each question carries 14 marks)

Module-1

11. a) Compare Juran and Deming approaches (7)

b) Explain the characteristics of Total Quality Management. (7)

OR

12 a) Explain the three TQM axioms. (12)

b) Define Quality Planning. (2)

Module-2

13. Describe the steps to be followed to integrate quality into strategic management journey of an organization. (14)

OR

14. (a) Enumerate the objectives and key principles of lean manufacturing paradigm. (7)

(b) Compare traditional and lean manufacturing paradigms. (7)

Module-3

15. What are self managing teams? What are the benefits and problems associated with them? Indicate the key steps to be followed to implement them in organizations. (14)

OR

16. What are the ingredients for success for a quality director? What are the activities to be carried out by a quality director towards assisting upper management with strategic management (14)

Module-4

17. With the aid of an example, describe the principles of cause and effect diagram. (14)

OR

18. Following are the data on the quality costs incurred in a manufacturing company in a month:

Title of the quality cost	Amount in Rupees
Product audits	1,000

Scrap Disposal	50,000
Concessions and Downgrading	40,000
Calibration	2,000
Quality planning	500
Manufacturing losses	30,000
System failure	40,000
Test materials	5,000
Training	2,000
Customer returns	25,000

Classify the above quality costs into preventive, appraisal and failure costs. Conduct Pareto analysis and comment on the results. Suggest a proposal with anticipation on the quality costs observable in future. (14)

Module-5

19. Describe the steps to be followed for conducting a quality audit. (14)

OR

20. Enumerate the steps to be followed by a manufacturing organization to obtain ISO 9001 certification. (14)

## Syllabus

### Module 1

Introduction to Quality Engineering - Definitions of the terms - quality, quality planning, quality control, quality assurance, quality management, Total Quality Management (TQM)- overview on TQM - the TQM axioms - consequences of total quality- Barriers to TQM- Deming approach to TQM – Juran’s quality trilogy- Crosby's fourteen steps for quality improvement

### Module 2

Strategic Quality Management: Cost of Quality- Customer satisfaction- Quality Function Deployment (QFD)- Integrating quality into strategic management - quality and the management cycle- obstacles to achieving successful strategic quality management- supplier selection- Concepts of 5S, Six Sigma, Lean, Kaizen

### Module 3

Human dimensions of TQM – Top management commitment- Leadership for TQM- Change management- resources for quality activities - training for quality –Employee involvement, motivation empowerment- teamwork- self managing teams - role of the quality director

### Module 4

Supporting Tools, Activities And Techniques in TQM Projects : Affinity diagram - brainstorming - cause and effect analysis - process flow chart – check sheets- Scatter diagram - Pareto chart- Histogram and fundamentals of statistics - Control charts for improving process capability- Taguchi’s robust design- Total Productive maintenance- Failure Mode and Effect Analysis

### Module 5

Quality System: ISO 9000 family of standards- ISO 9001:2000 model, quality management system- management responsibility- resource management- product realisation- measurement analysis and improvements- ISO 14000 family of standards- Quality auditing- types and benefits.

### Text Books

1. Besterfield Dale H. , Besterfield Carol, Besterfield Glen H., Besterfield Mary, Urdhwareshe Hemant, Urdhwareshe Rashmi, “Total Quality Management (TQM) 5e”, Pearson Education, 2018.
2. Subburaj Ramasamy, “Total Quality Management”, McGraw Hill Education,, 2017.
3. Dr. K.C. Arora, “Total Quality Management”, S K Kataria and Sons, 2013.
4. Suganthi, L and Anand A Samuel, “Total Quality Management”, Prentice Hall India Learning Private Limited, 2009.

5. Juran J M and Gryna, F M, "Quality Planning and Analysis - From Product Development through Use", Tata McGraw Hill Publishing Limited, New Delhi, Third Edition, 2004.

#### Reference Books

1. Logothetics N, "Managing for Total Quality - From Deming to Taguchi and SPC", Prentice Hall Ltd., New Delhi, 1997.
2. Deming W E, "Out of the Crisis," MIT Press, Cambridge, MA, 1982.
3. Juran J M and Juran on "Leadership for Quality" An Executive Handbook, The Free Press, New York, 1989.
4. Salor JH, "TQM-Field Manual," McGraw Hill, New York, 1992.
5. Crosby P B, "Quality is Free" McGraw Hill, New York, 1979.

#### Course Contents and Lecture Schedule

No	Topic	No. of Lectures
1	Introduction to Quality Engineering	
1.1	Definitions of the terms - quality, quality planning, quality control, quality assurance, quality management	2
1.2	Total Quality Management (TQM)- overview on TQM - the TQM axioms - consequences of total quality- Barriers to TQM	2
1.3	Deming approach to TQM - Juran quality trilogy- Crosby's fourteen steps for quality improvement	3
2	Strategic Quality Management	
2.1	Cost of Quality- Customer satisfaction- Quality Function Deployment (QFD)	2
2.2	Integrating quality into strategic management - quality and the management cycle- obstacles to achieving successful strategic quality management	2
2.3	Supplier selection	1
2.4	Concepts of 5S, Six Sigma, Lean, Kaizen	3
3	Human dimensions of TQM	
3.1	Top management commitment- Leadership for TQM- Change management	2
3.2	Resources for quality activities - training for quality	1
3.3	Employee involvement, motivation, empowerment	3
3.3	Teamwork- self managing teams - role of the quality director	1
4	Supporting Tools, Activities And Techniques in TQM Projects	
4.1	Affinity diagram - brainstorming	1
4.2	Cause and effect analysis - process flow chart – check sheets- Scatter diagram - Pareto chart	3
4.3	Histogram and fundamentals of statistics -	1
4.4	Control charts for improving process capability-	2
4.5	Taguchi's robust design- Total Productive maintenance- Failure	2

	Mode and Effect Analysis	
5	Quality System	
5.1	ISO 9000 family of standards	1
5.2	ISO 9001 model, quality management system- management responsibility- resource management- product realisation- measurement analysis and improvements	2
5.3	ISO 14000 family of standards	1
5.4	Quality auditing- types and benefits	1

COURSE CODE	COURSE NAME	CATEGORY	L	T	P	CREDITS
22MEE802.2	INDUSTRIAL HYDRAULICS	PROGRAM ELECTIVE III	2	1	0	3

Preamble: This course covers the fundamentals of operating principles, configuration features, functionalities, and applications of various elements in typical hydraulic systems

Prerequisite: NIL

Course Outcomes: After the completion of the course the student will be able to

CO 1	Identify the basic elements of a fluid power system
CO 2	Describe the properties of a hydraulic fluid
CO 3	Distinguish between different types of pumps
CO 4	Explain the operation and features of various hydraulic actuators
CO 5	Describe the purpose, construction and operation of various control valves
CO 6	Develop a hydraulic circuit to perform a desired function

Mapping of course outcomes with program outcomes

	PO 1	PO 2	PO 3	PO 4	PO 5	PO 6	PO 7	PO 8	PO 9	PO 10	PO 11	PO 12
CO 1	3	2										
CO 2	3	2										
CO 3	3	2										
CO 4	3	2										
CO 5	3	2										
CO 6	3	2										

Assessment Pattern

Bloom's Category	Continuous Assessment Tests		End Semester Examination
	1	2	
Remember	10	10	10
Understand	20	20	20
Apply	20	20	70
Analyse			
Evaluate			
Create			

### Mark distribution

Total Marks	CIE	ESE	ESE Duration
150	50	100	3 hours

### Continuous Internal Evaluation Pattern:

Attendance	: 10 marks
Continuous Assessment Test (2 numbers)	: 25 marks
Assignment/Quiz/Course project	: 15 marks

End Semester Examination Pattern: There will be two parts; Part A and Part B. Part A contain 10 questions with 2 questions from each module, having 3 marks for each question. Students should answer all questions. Part B contains 2 questions from each module of which student should answer any one. Each question can have maximum 2 sub-divisions and carry 14 marks.

### Course Level Assessment Questions

#### Course Outcome 1 (CO1):

1. Differentiate between hydraulic and pneumatic system
2. Discuss the advantages of fluid power
3. Describe key applications of fluid power
4. Identify the graphical symbols used for various components of fluid power system

#### Course Outcome 2 (CO2):

1. Describe the properties of hydraulic fluids
2. Discuss the primary functions of hydraulic fluid

#### Course Outcome 3 (CO3):

1. Explain various types of pumps
2. Compare the various performance factors of gear, vane and piston pumps
3. Explain pressure intensifiers
4. Describe various types of accumulators

#### Course Outcome 4(CO4):

1. Describe the construction and design features of hydraulic cylinders
2. Identify the various types of hydraulic cylinder cushioning and mountings
3. Explain various types of hydraulic motors

#### Course Outcome 5 (CO5):

1. Explain the construction, working and applications of various hydraulic control valves

2. Discuss the construction features and functions of conductors

Course Outcome 6 (CO6):

1. Illustrate different hydraulic circuits
2. Describe the applications of accumulator

Model Question Paper

Total Pages:

Reg No.: \_\_\_\_\_ Name: \_\_\_\_\_

EIGHTH SEMESTER B.TECH MINOR DEGREE  
EXAMINATION, COURSE CODE: MET424  
COURSE NAME: INDUSTRIAL HYDRAULICS

Max. Marks: 100

Duration: 3 Hours

PART A

*(Answer all questions; each question carries 3 marks)*

		Marks
1	Comment on the differences between pneumatic and hydraulic fluid power systems	3
2	Differentiate between viscosity and viscosity index. Under what conditions is viscosity index important?	3
3	Derive an expression for the actual volumetric displacement of the vane pump in terms of the dimensions of the pump components	3
4	Discuss about the influence of pressure, size and speed on pump noise level	3
5	Sketch and explain Tandem cylinder	3
6	List the advantages of a hydraulic motor over an electric motor	3
7	Discuss why all fluid power systems are fitted with a pressure relief valve	3
8	Explain the construction features and function of flexible hoses	3
9	Explain the purpose of a regenerative circuit	3
10	Write a note on accumulator as hydraulic shock absorber	3

PART B

*(Answer one full question from each module, each question carries 14 marks)*

Module -1

11	a) With the help of a neat sketch, explain the basic components of a hydraulic system	8
	b) Explain the advantages and disadvantages of a hydraulic system	6
12	a) Explain the desirable properties of hydraulic fluids	6
	b) Sketch and describe a rectangular flat-topped reservoir fitted with basic accessories.	8

Module -2

13	a) Explain with a neat sketch, the working of a gear pump. Also obtain an expression for its volumetric efficiency	8
----	--	---



- b) With a neat sketch, explain the working of a lobe pump. 6
- 14 a) With neat sketch, explain how vane pump can be made to work as a variable displacement pump without changing the speed of the prime mover 7
- b) Explain the construction and operation of piston-type accumulators 7

#### Module -3

- 15 a) Describe end cushion provided in hydraulic cylinder with neat sketch
- b) With the help of a neat sketch, explain the construction and working of a balanced vane motor. Give its main advantage over vane motor.
- 16 a) Sketch a semi-rotary vane motor. Derive an expression for its torque capacity 6
- b) With a neat diagram, explain the construction and working of in line piston motor (Bent axis design). 8

#### Module -4

- 17 a) Give the classification of check valves and explain the construction and working of pilot-operated check valve, giving the necessary drawing. 7
- b) Explain with neat sketch, how three way and four way direction control valve operate 7
- 18 a) With a neat sketch, explain the construction and working of pressure reducing valve 7
- b) With a neat sketch, explain spool type direction control valve used to control double acting cylinder 7

#### Module -5

- 19 a) Describe with a neat circuit diagram, fail-safe system that provide overload protection for system components. 6
- b) Draw the sequencing circuit for operating two double acting cylinders in a sequence in both strokes. Use appropriate component for the circuit & explain its working for a hydraulic system 8
- 20 a) With a neat circuit diagram, explain the working of a meter out circuit for controlling the speed of a cylinder 6
- b) The table of a surface grinding machine needs automatic reciprocating motion. Draw a hydraulic circuit to achieve this motion 8

## Syllabus

### Module 1

Introduction to fluid power: - Classification of fluid power systems- Basic components, Symbols & circuits of a hydraulic and pneumatic system, Properties of fluids

Hydraulic fluids and fluid handling components: - Fluid for hydraulic systems- Hydraulic fluids reservoirs- Hydraulic seals- Filters and Strainers

### Module 2

Hydraulic pumps:- Classification and pumping theory- Principle of working and constructional details of vane pump, gear pumps, radial and axial plunger pumps- Pump performance

Hydraulic pressure intensifiers, Power storage devices –Accumulators

### Module 3

Hydraulic actuators:- Linear hydraulic actuators-Types, Cylinder cushions, Rotary actuators – Classification, construction and working of gear, vane, axial and radial piston motors- Limited rotation hydraulic actuators- Hydraulic motor performance

### Module 4

Hydraulic control valves:-Classification of control valves- Directional control valves- Pressure control valves- Flow control valves- Servo valves

Hydraulic conductors

### Module 5

Hydraulic circuits:- Control of single and double -acting hydraulic cylinder, Regenerative circuit- Pump-unloading circuit, Double-pump hydraulic system, Pressure intensifier circuit, Counter balance valve application, Hydraulic cylinder sequencing circuits, Automatic cylinder reciprocating system, Locked cylinder using pilot check valves, Cylinder synchronizing circuits- Speed control of a hydraulic cylinder, Bleed-off flow control circuit- Fail-safe circuits- Hydraulic motor braking system, Hydraulic circuit examples with accumulator

### Text Books

Anthony Esposito, Fluid Power with Applications, Pearson Education India, 2013 NIL

### Reference Books

1. J. J. Pipenger, Tyler Gregory Hicks, Industrial Hydraulics, McGraw Hill, 1979
2. Herbert E. Merritt, Hydraulic Control Systems, John Wiley & Sons, 1967

3.S R Majumdar, Oil hydraulic systems: Principles and Maintenance, McGraw Hill Education, 2017

4. Qin Zhang, Basics of hydraulic systems, CRC Press, 2018

#### Course Contents and Lecture Schedule

No	Topic	No. of Lectures
1	Introduction to fluid power systems	
1.1	Introduction to fluid power – Classification of fluid power systems, Hydraulics and pneumatics systems, Hydrostatic and hydrodynamic Systems, Advantages, disadvantages and applications of fluid power	1
1.2	Basic components, symbols & circuits of a hydraulic and pneumatic system, Comparison between hydraulic and pneumatic systems, Comparison of different power systems	2
1.3	Properties of fluids- Density, Specific weight, Specific volume and Specific gravity- Pressure, head and force- Pascal’s law and its applications-Bulk modulus-Viscosity and viscosity index	1
1.4	Hydraulic fluids and fluid-handling components:-Fluid for hydraulic systems-Functions of hydraulic fluid, desired properties of hydraulic fluid, Types of hydraulic fluids, Additives and their purposes, Factors influencing the selection of a fluid	1
1.5	Hydraulic fluids reservoirs- Functions, Design and constructional features, Sizing of the reservoir	1
1.6	Hydraulic seals- O-rings, Compression packings, piston cup packings, piston rings and wiper rings, Seal materials-Filters and Strainers - Types of filters, Beta Ratio of filters	1
2	Hydraulic pumps	
2.1	Hydraulic pumps: Classification and pumping theory, Gear pump- Construction and working of external gear pump, Advantages and disadvantages, Theoretical flow rate	1
2.2	Construction and working of Internal gear pump, Lobe pump, Gerotor pumps and Screw pump	1
2.3	Construction and working of Vane pump, Advantages and disadvantages ,Theoretical flow rate, Variable displacement vane pump- Balanced vane pump, Advantages and disadvantages	1
2.4	Piston pump- Axial and radial design, Axial piston pump (Bent-axis design, Swash-plate-type piston pump, and Radial piston pump	1
2.5	Pump performance-Volumetric efficiency, Mechanical efficiency and Overall efficiency, Pump performance curve, Pump noise and Pump selection	1
2.6	Hydraulic pressure intensifier:-axial-piston style single and	1

	double-acting hydraulic pressure intensifiers	
2.7	Power storage devices -Accumulators: Types-Weight loaded or gravity type, Spring loaded type and Gas loaded (Nonseparator and separator) type	1
3	Hydraulic actuators	
3.1	Linear hydraulic actuators-Types-Single acting and double acting cylinders, Ram cylinders, Telescopic cylinders and Tandem cylinders	1
3.2	Cylinder cushions, Cushioning pressure, Cylinder force, Velocity and Power, Acceleration and deceleration of cylinder loads	1
3.3	Cylinder mountings, Mechanics of hydraulic cylinder loadings-First class, Second class and Third class lever systems	1
3.4	Rotary actuators – Classification, Construction and working of gear, vane, balanced vane, axial (Swash plate and Bent-axis design) and radial piston motors, Limited rotation hydraulic actuators	2
3.5	Theoretical torque, power, flow rate, hydraulic motor performance- volumetric efficiency, mechanical efficiency and overall efficiency, Performance characteristics of hydraulic motor, Comparison of gear, vane and piston motor, Simple numerical problems	2
4	Hydraulic control valves	
4.1	Hydraulic control valves-Classification of control valves, Directional control valves-symbolic representation, constructional features of poppet, sliding spool, rotary spool valves, Manual, mechanical, solenoid and pilot operated DCV, shuttle valve, and check valves-Two way, Three way, and Four way valves-Applications	2
4.2	Pressure control valves – types, Simple pressure-relief valve, Compound pressure-relief valve, Pressure-reducing valve, Unloading valve, Counterbalance valve and Pressure-sequence valve- Applications	2
4.3	Flow control valves – Functions of flow control valves, Factors that determine the flow rate across an orifice or a restrictor, compensated and non-compensated FCV, needle valve, temperature compensated, pressure compensated, pressure and temperature compensated FCV, symbolic representation.	1
4.4	Servo valves-Mechanical-hydraulic servo valve, Electrohydraulic servo valve, Proportional control valves	1
4.5	Hydraulic conductors- Conductor sizing, Pressure rating of conductors, Steel pipes, Steel tubing, Plastic conductors and Flexible hoses, Pressure losses in hydraulic conduits	1
5	Hydraulic circuits	
5.1	Control of single and Double -acting hydraulic cylinder,	1

	Regenerative circuit- Expression for the cylinder extending speed	
5.2	Pump-Unloading Circuit, Double-pump hydraulic system, Pressure intensifier circuit, Counter balance valve application	1
5.3	Hydraulic cylinder sequencing circuits, Automatic cylinder reciprocating system	1
5.4	Locked cylinder using pilot check valves, Cylinder synchronizing circuits- Parallel and series	1
5.5	Speed control of a hydraulic cylinder-meter-in and meter-out circuit, Meter-in and meter-out flow control of both strokes, Bleed-off flow control circuit	1
5.6	Fail-Safe circuits- Protection from inadvertent cylinder extension and fail-safe overload protection	1
5.7	Hydraulic motor braking system, Hydraulic circuit examples with accumulator- Accumulator as an auxiliary power source, Accumulator as a leakage compensator, Accumulator as an emergency power source, Accumulator as a shock absorber	1



### Assessment Pattern

Bloom's Category	Continuous Assessment Tests		End Semester Examination
	1	2	
Remember			
Understand	20	20	30
Apply	30	30	70
Analyse			
Evaluate			
Create			

### Mark distribution

Total Marks	CIE	ESE	ESE Duration
150	50	100	3 hours

### Continuous Internal Evaluation Pattern:

Attendance	: 10 marks
Continuous Assessment Test (2 numbers)	: 25 marks
Assignment/Quiz/Course project	: 15 marks

End Semester Examination Pattern: There will be two parts; Part A and Part B. Part A contain 10 questions with 2 questions from each module, having 3 marks for each question. Students should answer all questions. Part B contains 2 questions from each module of which student should answer any one. Each question can have maximum 2 sub-divisions and carry 14 marks.

### Course Level Assessment Questions

#### Course Outcome 1 (CO1):

1. Derive the expression for membrane stresses in axisymmetric shell structure under internal pressure
2. Derive the expression for dilation in cylindrical and spherical pressure vessels under internal pressure
3. Explain the conditions for buckling in ellipsoidal shells and discuss the remedies

#### Course Outcome 2 (CO2)

1. Derive the Lamé's equations of stresses in thick cylinder under internal pressure
2. Find out the stress pattern developed in case of built up cylinders under a given interference

after assembly

3. What are thermal stresses in a pressure vessel and how they are evaluated

Course Outcome 3(CO3):

1. Explain the design steps in the design of tall cylindrical vessel under wind load
2. Explain with neat sketches the supports used in the case of vertical tall self-supported cylindrical vessels
3. Explain with sketches, various stresses developed in a saddle supported horizontal pressure vessel

Course Outcome 4 (CO4):

1. Derive the expression for critical buckling pressure for cylinder under external pressure
2. Explain with sketches the support design for pipes under external pressure
3. Explain the design curves for design of cylinders under both external pressure and compressive axial loading

Course Outcome 5 (CO5):

1. Explain the flexibility analysis of piping system
2. what is meant by modes of fracture? What is stress intensity factor
3. Explain failure assessment diagram and its usage

Model Question Paper

APJ ABDUL KALAM TECHNOLOGICAL UNIVERSITY  
EIGHTH SEMESTER B. TECH DEGREE EXAMINATION  
Course Code: MET 434  
Course Name: PRESSURE VESSEL AND PIPING DESIGN

Max. Marks: 100

Duration: 3 Hours

PART – A

(ANSWER ALL QUESTIONS, EACH QUESTION CARRIES 3 MARKS)

Part-A

1. Explain the stresses developed in a conical cylinder under internal pressure?
2. Derive the expression for dilation of a spherical shell under internal pressure?
3. Explain with sketches the stress pattern in a built-up cylinder after assembly?
4. Derive the expression for internal pressure for the full cross section yielding of a cylinder?
5. Explain with sketches, any two types of supports used for tall cylindrical vessels?
6. What are the different sections of ASME pressure vessel code?
7. Explain with sketches, stiffener support for pipe under external pressure?
8. Explain the design curves for pipe under both external and axial compressive loading?



9. What is meant by flexibility analysis?  
10. What is meant by modes of fracture?

(10X3=30)

PART – B

(ANSWER ONE FULL QUESTION FROM EACH MODULE)

MODULE – 1

11. (a) Derive the general expression for stress equilibrium in an axisymmetric shell under internal pressure (6 marks)
- (b) Derive the expression for membrane stresses in an elliptical shell and bring out the condition for local buckling (8 marks)
- OR
12. (a) Derive the expression for stresses developed in a thin cylinder under internal pressure (6 marks)
- (b) Derive the expression for membrane stresses developed in a torus under internal pressure (8 marks)

MODULE – 2

13. (a) A short Thick cylinder with 1000 mm internal diameter and 1300mm outside diameter subjected to an internal pressure of 40 MPa. Determine the location and magnitude of maximum tangential, radial, shear stresses induced. Find also the dilation of its inner and outer radii. (10 marks)
- (b) Sketch the variation of stresses across the thickness of thick cylinder under internal pressure (4 marks)

OR

14. (a) A steel tube of 240 mm external diameter is shrunk on another steel tube of 80 mm internal diameter. Diameter of junction is 160mm. The interference before shrinking is 0.08 mm. Find the tangential stress at outer surface of inner tube (ii) the tangential stress at the inner surface of the outer tube and (iii) radial stress at the junction after assembly.  $E=200$  GPa (6 marks)
- (b) Derive the expression for the internal pressure for intermittent yielding of cylindrical pressure vessels? (8 marks)

MODULE – 3

15. (a) Explain the design procedure of a tall vessel under wind load as per ASME code? (8 marks)

- (b) Explain with sketches, various supports used in case of tall vessel? (6 marks)

OR

16. (a) Explain the procedure followed in the case of tall vessel under seismic load? (8 marks)  
(b) Explain with sketches, various supports used in case of horizontal pressure vessels under internal pressure? (6 marks)

MODULE – 4

17. (a) Derive the critical buckling pressure for a circular ring under external pressure? (8 marks)  
(b) Explain the procedure for pipe sizing under external pressure? (6 marks)

OR

18. (a) Discuss the classification of cylinders for design for buckling as per ASME code. (6 marks)  
(b) Explain the following terms (i) factors A & B for vacuum design (ii) Buckling coefficients (iii) effect of imperfections on buckling strength ? (8 marks)

MODULE – 5

19. (a) Discuss various methods to increase flexibility in a piping system. (6 marks)  
(b) A thick walled cylinder with 300 MPa internal pressure, internal diameter 300mm external diameter 600 mm is having a semi elliptical defect 10mm deep on the inside surface. The aspect ratio of the flaw is 0.1. Check whether vessel is satisfactory from fracture point of view.  $K_{IC} = 180 \text{ MPa}\sqrt{m}$ . (8 marks)

OR

- 20.(a) Explain the following (i) Displacement stress range (ii) stress range reduction factor (ii) Sustained and occasional loads. (7 marks)  
(b) Explain (i) fracture toughness (ii) leak before break (iii) through thickness/surface flaws. (7 marks)

## Syllabus

### Module 1

Pressure vessel – Terminology – Types of loads – Types of pressure- Stresses in pressure vessels – Dilation of pressure vessels – Membrane stress analysis of vessel shell components  
Cylindrical shells, spherical shells, torus, conical head, elliptical head  
Bending of circular plates under uniform pressure load with simply supported and clamped edges (no derivation)

### Module 2

Stresses in thick walled cylinders – Lamé's equation for internal and external pressure  
Shrink-fit stresses in Built up cylinders, autofrettage of thick cylinders, Thermal stresses and their significance

### Module 3

Design of pressure vessels- shell and support design of tall vessel under wind and seismic load  
Shell and support design of horizontal vessels  
Familiarization with relevant ASME codes and standard practices in pressure vessel design

### Module 4

Buckling -Elastic buckling of cylinders or pipes under external pressure- Pipe sizing under external pressure- Design of Stiffeners  
Buckling under combined compressive pressure and axial load

### Module 5

Pipe stress Analysis -allowable displacement stress range for expected cyclic life-stress intensification factor and flexibility factor-Flexibility Analysis (Analysis as per clause 119.7.1 in Code ASME B31.1/clause 319.4.1 in ASME B31.3 only)  
Fracture based design of pressure vessels- modes of fracture-stress intensity factor -through thickness and surface cracks in pressure vessels (mode-I only)-fracture toughness-leak before break-failure assessment diagram

### Text Books

1. John F. Harvey, "Theory and Design of Pressure Vessels" CBS Publisher and Distributors
2. Brownell, L. E., and Young, E. H., "Process Equipment Design", John Wiley and Sons
3. Somnath Chathopadhyay, "Pressure Vessels Design and practice", C. R. C Press
4. Prashant Kumar, "Elements of fracture mechanics", McGraw Hill Education India

### Reference Books

1. Henry H. Bender, "Pressure Vessels Design hand book"
2. ASME Pressure Vessel Codes Section VIII, 2006
3. Dennis Moss,"Pressure Vessel Design Manual" Gulf publishing, 2003

4. J. Phillip Ellenberger, "Pressure Vessels: ASME Code Simplified", ASME
5. "American standard code for pressure piping, B 31.1", ASME.
6. Smith P, "Fundamentals of Piping Design", Elsevier
7. ASME Pressure Vessel and Boiler code, Section VIII Div. 1, 2, and 3", ASME
8. T. L Anderson "Fracture Mechanics: Fundamentals and applications" Taylor & Francis
9. D. Broek, "Elementary Engineering Fracture Mechanics", Kluwer Academic Publications

#### Course Contents and Lecture Schedule

No	Topic	No. of Lectures
1	Design of thin pressure vessels	
1.1	Membrane stresses in general axisymmetric shell under internal pressure	3
1.2	Stresses and dilation in various kinds of components	2
1.3	Bending plates	2
2	Design of thick pressure vessels	
2.1	Stresses in thick walled cylinders – Lamé's equation - Shrink fit stresses in built up cylinders in Built up cylinders	3
2.2	Autofrettage in cylinders	2
2.3	Thermal stresses and significance	2
3	Vertical and horizontal vessel design	
3.1	Design of tall vertical shell structure and its supports	3
3.2	Design of shell and supports for horizontal vessels	3
3.3	Familiarization with standards and codes	2
4	Buckling Analysis	
4.1	Derivation of critical buckling pressure under external pressure	2
4.2	Pipe sizing and stiffener support design	3
4.3	Combined circumferential and axial buckling design	2
5	Flexibility analysis and fracture design	
5.1	Pipe stress and flexibility analysis	2
5.2	Fracture fundamentals	2
5.3	SIFs, leak before break and failure assessment diagram	3

COURSE CODE	COURSE NAME	CATEGORY	L	T	P	CREDITS
22MEE802.4	DATA ANALYTICS FOR ENGINEERS	PROGRAM ELECTIVE III	2	1	0	3

Preamble: The student will understand the techniques to analyse different types of data, characterize it and can apply them to make decision modelling process more intelligent.

Prerequisite: *Nil*

Course Outcomes: After the completion of the course the student will be able to

CO 1	Explain different data analysis techniques
CO 2	Discuss the concepts behind the descriptive analytics and predictive analytics of data
CO 3	Familiarize with Big Data and its sources
CO 4	Illustrate different visualization techniques in data analysis

Mapping of course outcomes with program outcomes

	PO 1	PO 2	PO 3	PO 4	PO 5	PO 6	PO 7	PO 8	PO 9	PO 10	PO 11	PO 12
CO 1	3	3	3	1					1			2
CO 2	3	3	3	3					1			1
CO 3	3	3	3	1		1			1			1
CO 4	3	3	3	3								

Assessment Pattern

Bloom's Category	Continuous Assessment Tests		End Semester Examination
	1	2	
Remember	10	10	30
Understand	30	30	40
Apply	10	10	30
Analyse			
Evaluate			
Create			

## Mark distribution

Total Marks	CIE	ESE	ESE Duration
150	50	100	3 hours

### Continuous Internal Evaluation Pattern:

Attendance	: 10 marks
Continuous Assessment Test (2 numbers)	: 25 marks
Assignment/Quiz/Course project	: 15 marks

End Semester Examination Pattern: There will be two parts; Part A and Part B. Part A contain 10 questions with 2 questions from each module, having 3 marks for each question. Students should answer all questions. Part B contains 2 questions from each module of which student should answer any one. Each question can have maximum 2 sub-divisions and carry 14 marks.

### Course Level Assessment Questions

#### Course Outcome 1 (CO1):

1. Explain the different types of prediction errors.
2. What is the need for sampling? Explain about different sampling methods.
3. Compare and contrast analysis and reporting in data analytics with suitable example

#### Course Outcome 2 (CO2)

1. Differentiate descriptive and predictive analysis technique.
2. Explain how attribute selection is carried out in decision tree induction.
3. Write different steps in Apriori algorithm used for finding frequent item sets.

#### Course Outcome 3(CO3):

1. Explain 3V's in big data analytics
2. List the different sources of bigdata.
3. With suitable example, give the difference between Business intelligence and data analytics.

#### Course Outcome 4 (CO4):

1. Discuss file system used for big data analysis.
2. Explain how recommender systems help in big data analysis.
3. Explain different techniques used for data visualization,

Model Question Paper

VIII SEMESTER B.TECH EXAMINATION

MET444 DATA ANALYTICS FOR ENGINEERS

PART A

Answer all questions, each carries 3 marks

1. Explain how significance level affects inferences drawn from data.
2. Define the term correlation between data points.
3. Differentiate classification and prediction.
4. State the different activation functions used in neural networks.
5. Give a brief description about how to perform descriptive analysis in a dataset.
6. Explain frequent item sets in association rule mining with example ?
7. Define bigdata.
8. List the challenges in big data acquisition
9. Explain the term social media analytics.
10. What is the significance of scatter plot matrix?

PART B

Answer any one Question from each module. Each question carries 14 Marks

Module I

11. Give the significance of resampling technique. Explain the different types of resampling techniques.
12. Describe the process of hypothesis technique with the help of a suitable example.

Module II

13. Illustrate regression analysis in predictive modelling.
14. Explain how principal components are extracted using PCA.

Module III

15. Differentiate K-means and hierarchical clustering techniques with suitable example.
16. Describe market-based model used in descriptive analysis.

## Module IV

17. With the help of a neat diagram, describe data analytics lifecycle.
18. a. Describe the characteristics of Big data?  
b. Summarize the challenges and applications of big data analytics

## Module V

19. What is HDFS? How does it handle Big Data?
20. Illustrate and explain the concept of Map Reduce framework

## Syllabus

### Module 1 (7 hours)

Introduction to Data Analysis - Evolution of Analytic scalability, analytic processes and tools, Analysis vs reporting - Modern data analytic tools. Statistical concepts: Sampling distributions, re-sampling, statistical inference, prediction error.

### Module 2 (7 hours)

Predictive Analytics – Regression, Decision Tree, Neural Networks. Dimensionality Reduction - Principal component analysis

### Module 3 (7 hours)

Descriptive Analytics - Mining Frequent item sets - Market based model – Association and Sequential Rule Mining - Clustering Techniques – Hierarchical – K- Means

### Module 4 (6 hours)

Introduction to Big data framework - Fundamental concepts of Big Data management and analytics - Current challenges and trends in Big Data Acquisition

### Module 5 (8 hours)

Popular Big Data Techniques and tools- Map Reduce paradigm and the Hadoop system- Applications Social Media Analytics, Recommender Systems- Fraud Detection

### Text Books

1. EMC Education Services, Data Science and Big Data Analytics: Discovering, Analyzing, Visualizing and Presenting Data. John Wiley & Sons, 2015.
2. Jaiwei Han, Micheline Kamber, “Data Mining Concepts and Techniques”, Elsevier, 2006.
3. Michael Berthold, David J. Hand, Intelligent Data Analysis, Springer, 2007.2.



## Reference Books

1. Bart Baesens," Analytics in a Big Data World: The Essential Guide to Data Science and its Business Intelligence and Analytic Trends", John Wiley & Sons, 2013  
Challenges and Future Prospects, Springer, 2014.

## Course Contents and Lecture Schedule

No	Topic	No. of Lectures
	Module 1	
1.1	Introduction to Data Analysis - Evolution of Analytic scalability	1
1.2	Analytic processes and tools	2
1.3	Analysis vs reporting - Modern data analytic tools	2
1.4	Statistical concepts: Sampling distributions, re-sampling, statistical inference, prediction error.	2
	Module 2	
2.1	Predictive Analytics – Regression	2
2.2	Decision Tree	2
2.3	Neural Networks	1
2.4	Dimensionality Reduction - Principal component analysis	2
	Module 3	
3.1	Descriptive Analytics - Mining Frequent item sets	2
3.2	Market based model	2
3.3	Association and Sequential Rule Mining	1
3.4	Clustering Techniques – Hierarchical	1
3.5	K- Means	1
	Module 4	
4.1	Introduction: Fundamental concepts of Big Data management and analytics	1
4.2	Data Analytics Lifecycle Overview	2
4.3	Current challenges and trends in Big Data Acquisition	2
	Module 5	
5	Popular Big Data Techniques and tools	1
5.1	Map Reduce paradigm	2
5.2	Hadoop system	2
5.3	Applications Social Media Analytics, Recommender Systems- Fraud Detection	2
5.4	Data Visualization techniques-overview	1

COURSE CODE	COURSE NAME	CATEGORY	L	T	P	CREDITS
22MEE802.5	INDUSTRIAL TRIBOLOGY	PROGRAM ELECTIVE III	2	1	0	3

Preamble: The need for structural integrity of the surfaces of components is an essential requirement from the point of view of reliability of industrial components. Surfaces need to possess special properties so to prevent material loss, and to perform with minimal energy losses by way of friction. Surface treatment methods and prudent lubrication strategies coupled with testing-equipment/probes for conducting the tribological investigations form the basic aspects of tribological management in an industry. This course is meant to introduce the basic aspects of tribology, which a practising engineer or an engineer-analyst working in this area would require.

Prerequisite: Nil

Course Outcomes: After the completion of the course the student will be able to

CO 1	Apply Surface characterisation techniques for tribological investigations
CO 2	Explain theories of friction.
CO 3	Apply theories of wear for industrial problems.
CO 4	Explain Lubrication methods employed in Industrial scenarios.
CO 5	Explain Surface Coating techniques for industrial applications.

Mapping of course outcomes with program outcomes

	PO 1	PO 2	PO 3	PO 4	PO 5	PO 6	PO 7	PO 8	PO 9	PO 10	PO 11	PO 12
CO 1	3	2	1		3							
CO 2	3	2	1									
CO 3	3	2	1									
CO 4	3	2					1					
CO 5	3	2	1									

Assessment Pattern

Bloom's Category	Continuous Assessment Tests		End Semester Examination
	1	2	
Remember			
Understand	30	30	80
Apply	20	20	20
Analyse			
Evaluate			
Create			

### Mark distribution

Total Marks	CIE	ESE	ESE Duration
150	50	100	3 hours

#### Continuous Internal Evaluation Pattern:

Attendance	: 10 marks
Continuous Assessment Test (2 numbers)	: 25 marks
Assignment/Quiz/Course project	: 15 marks

End Semester Examination Pattern: There will be two parts; Part A and Part B. Part A contain 10 questions with 2 questions from each module, having 3 marks for each question. Students should answer all questions. Part B contains 2 questions from each module of which student should answer any one. Each question can have maximum 2 sub-divisions and carry 14 marks.

#### Course Level Assessment Questions

##### Course Outcome 1 (CO1):

1. Realize the importance of tribology in mechanical engineering design.
2. Introduce tribology as a Surface Science.
3. Introduce the student to surface characterisation.
4. Learn some specific methods for physical and chemical characterisation of surfaces.

##### Course Outcome 2 (CO2)

1. Define coefficient of friction.
2. Learn an equipment to measure friction at the interface of a tribological pair.
3. Analyse different regimes of lubrication in terms of the Stribeck curve.
4. Learn some aspects of the theory of hydrodynamic lubrication
5. Learn the plowing and adhesion theories of friction

##### Course Outcome 3(CO3):

1. Define Wear, and methods of quantifying wear.
2. Learn theories of wear.

3. Learn about (i) Four Ball Tester and (ii) Pin-on-disk tester equipment to quantify wear.
4. Discuss wear and friction aspects, in common mechanical engineering scenarios.

Course Outcome 4 (CO4):

1. Introduce methods of classifying lubricants.
2. Learn the use of different lubricants for different industrial applications.
3. Learn about additives in industrial lubricants.
4. Create awareness related to environmental aspects while using lubricants.

Course Outcome 5 (CO5):

1. Introduction to surface treatments for better tribological performance.
2. Learn some specific methods employed in surface engineering for industrial applications.
3. Introduction to maintenance of tribological components and diagnostic methods for health assessment of bearings.

Model Question Paper

MODEL QUESTION PAPER  
EIGHTH SEMESTER B.TECH DEGREE  
EXAMINATION

COURSE CODE : MET454

COURSE NAME : INDUSTRIAL TRIBOLOGY

MAX. MARKS : 100

DURATION : 3 HOURS

PART – A

(ANSWER ALL QUESTIONS, EACH QUESTION CARRIES 3 MARKS)

1. Write a short note on surface failure modes of machine components.
2. Enumerate few roughness parameters and their significance.
3. Explain the Stribeck diagram with the aid of a typical sketch.
4. Explain the *film-thickness-parameter* used to demarcate boundary lubrication regime.
5. Differentiate between fatigue wear and fretting wear.
6. What is running-in? How is it taken care of in the case of new automobiles?
7. What are extreme pressure lubricants? Make a short note on one method of testing their effectiveness.
8. Write a short note on SAE classification of lubricants.
9. Make a short note on coatings for metal cutting tools.
10. Write a short note on the tribological maintenance of roller chains and wire ropes in industry.

PART – B

(ANSWER ONE FULL QUESTION FROM EACH MODULE)

MODULE – 1

11. (a) Differentiate between (i) backscattered and (ii) secondary images as obtained from a SEM and when is one imaging type preferred over the other? If you want to image surface relief on a surface undergone wear, which type would you use? Why? (7 Marks)
- (b) On the same surface, if you want to analyse the distribution of phases on it, which of the above modes should be used? If an element-wise gross estimation of the metallic composition of the transfer layer formed on the surface is to be obtained, can it be made possible within a SEM? How is it realized? Explain the phenomena. (7 Marks)

OR

12. (a) Compare finding the chemical composition of the surface layer using (I) Energy Dispersive X-ray (EDX) analysis and (ii) X-ray photo-electron spectroscopy. When will you prefer one method over the other? (5 Marks)

(b) Compare roughness characterization using (i) mechanical stylus interferometry and (ii) optical interferometry. Discuss the merits and de-merits of each method. (5 Marks)

(c) Write short notes on Fractal characterisation of surfaces (ii) Bearing- area-curve (4 Marks)

#### MODULE – 2

13. Derive the Reynolds' one dimensional bearing lubrication equation which expresses the pressure-gradient in terms of entraining velocity and film thickness factors. What are the simplifying assumptions involved in the derivation? How can this equation be used to determine the load carrying capacity of a hydrodynamic bearing? Plot the radial pressure distribution in the case of a cylindrical journal in a long hydrodynamic bearing. (14 Marks)

OR

14. (a) Compare theories of friction. (5 Marks)

(b) Describe method to visualize and lubricant film and make measurements, in a laboratory experiment. (7 Marks)

(c) Viscosity of the lubricant is not a significant parameter under boundary lubrication conditions-discuss. (2 Marks)

#### MODULE – 3

15. (a) Derive the Archard's wear equation. What is the usual range of values for Archard's wear coefficient? (5 Marks)

(b) Discuss methods of quantifying wear (2 Marks)

(c) Compare wear theories (7 marks)

OR

16. (a) Are friction and wear always correlated? Discuss (4 Marks)

(b) Compare and contrast pin-on-disk testing and four-ball-wear-testing (6 Marks)

(c) Write a short note on improving wear resistance of cylinder liners in engines. (4 Marks)

#### MODULE – 4

17. (a) Make short notes on the following terms in the context of liquid lubricants: (i) Viscosity Index (ii) ISO viscosity grades (iii) SAE viscosity grades (iv) pour point depressants (v) Anti Wear (AW) and Extreme pressure (EP) additives (vi) Bio-degradability (vii) Eco-toxicity (14 Marks)

OR

18. (a) Metal working fluids have functions different from that of usual tribological fluids used in industry- discuss. (3 Marks)
- (b) What are the factors limiting the applicability of vegetable oils for tribological applications in automobiles. (2 Marks)
- (c) Discuss methods for engine oil testing (3 Marks)
- (d) Explain Environmental impact assessment related to lubricating oils (3 Marks)
- (e) Explain the classification of engine oils (3 Marks)

MODULE – 5

- 19 (a) Explain different methods used for testing of coatings (4 Marks)
- (b) Briefly describe about the application of engineering coatings in aircraft industry (4 Marks)
- (c) Differentiate between PVD and CVD processes with practical examples from industry applications (6 Marks)

OR

- 20 (a) What are signs of bearing failure? Explain a diagnostic method of monitoring bearing health? (7 Marks)
- (b) Discuss improvements in Cylinder-liner technologies for improved tribological performance in IC engines. (7 Marks)

## Syllabus

### Module 1 (7 Hours)

Tribology as a Surface Science- Tribological considerations in design of machine elements, and industrial maintenance - surface failure of machine components-Physical and chemical characterization of surfaces-Surface roughness- tools for roughness characterization-Industrial norms in roughness quantification/characterization-surface finish symbols-Characterization of surface morphology – The Scanning Electron Microscope- backscattered and secondary imaging- X-ray dispersive analysis-. X-ray photo-electron spectroscopy and chemical characterization of surface films.

### Module 2 (7 Hours)

Friction-coefficient of friction- Stribeck curve-Lubrication regimes- Film thickness parameter- Fundamentals of hydrodynamic lubrication - Hydrodynamic pressure profile-Visualization and Measurement of film thickness in well lubricated contacts. Boundary lubrication-plowing and adhesion components-Pin-on-plate arrangement to measure friction. Theories of friction

### Module 3 (7 Hours)

Wear – wear of metals-wear of polymers- Types of wear: adhesive wear-abrasive wear-corrosive wear-fretting wear- quantification of wear- wear debris analysis. Pin-on-disk machine and the Four Ball Tester. Friction and wear in the context of internal combustion engines, Bearings, Gears, cams and tappets, and in metal machining.

### Module 4 (8 Hours)

Lubricants: Classification according to Carbon distribution-Viscosity Index-Viscosity Grades and their choice for various applications-Engine oil viscosity classification. Selection of industrial Lubricating oils. Metal working lubricants. Types of additives in lubricants for improved tribological performance. Environmental aspects and sustainability aspects related to use and disposal of lubricating oils, recycling.

### Module 5 (7 Hours)

Surface Engineering: Thermal Diffusion Methods(carburizing,Nitriding, Nitro-carburising, boriding, chromizing) –Methodical Methods for coating development-PVD Methods-CVD Methods-Electrochemical deposition-Thermal spraying.

Bearings-Classification of Bearings-Bearing materials-Bearing maintenance, diagnostic maintenance of Tribological components and considerations in IC engines and automobile parts, roller chains and wire ropes.

### Text Books

1. Prasanta Sahoo, “Engineering Tribology”, PHI, New Delhi, 2005.
2. John Williams, “Engineering Tribology”, Illustrated edition, Cambridge University Press, 2005.



3. R.D. Arnell, P. B. Davies, J. Halling, T. L. Whomes, “Tribology: Principles and Design Applications “, 1991.

#### Reference Books

1. Theo Mang, Kirsten Bobzin, and Thorsten Bartels, “Industrial Tribology- Tribosystems, Friction, Wear and Surface Engineering, Lubrication”, Wiley-VCH; First edition, 2011.

2. B. Bhushan,” Principles and Application of Tribology”, Wiley, Second Edition, 2013.

3. G. W. Stachowiak and A. W. Batchelor, “Engineering Tribology”, Butterworth-Heinemann, Second revised edition, 2000.

#### Course Contents and Lecture Schedule

No	Topic	No. of Lectures
1	Module-1	7
1.1	Importance of Tribology in design of machine elements	1 Hour
1.2	Surface roughness- Industrial norms in roughness quantification- surface finish symbols	1 Hour
1.3	Tools for roughness characterization-	1 Hour
1.4	The Scanning Electron Microscope-	1 Hours
1.5	backscattered and secondary imaging- X-ray dispersive analysis	1 Hours
1.6	X-ray photo-electron spectroscopy and chemical characterization and surface films.	2 hours
2	Module-2	7
2.1	Coefficient of friction and Pin-on-plate arrangement to measure friction.	1 Hour
2.2	Stribeck curve-Lubrication regimes- Film thickness parameter	1 Hour
2.3	Fundamentals of hydrodynamic lubrication - Hydrodynamic pressure profile	2 Hours
2.4	Visualization and Measurement of film thickness in well lubricated contacts	1 Hour
2.5	Boundary lubrication-plowing and adhesion components	1 Hour
2.6	Theories of friction	1 Hour
3	Module-3	7
3.1	Wear of metals	1 Hour
3.2	Types of wear	1 Hours
3.3	Quantification of wear	1 Hour
3.4	Wear of polymers	1 Hour

3.5	Pin-on-disk machine and the Four Ball Tester.	1 Hour
3.6	Friction and wear in the context of internal combustion engines, Bearings, Gears, cams and tappets, and in metal machining.	2 Hours
4	Module-4	8
4.1	Classification of liquid lubricants according to Carbon distribution-	1 Hour
4.2	Viscosity Index-Viscosity Grades and their choice for various applications	2 Hours
4.3	Engine oil viscosity classification	1 Hour
4.4	Selection of industrial Lubricating oils. Metal working lubricants.	2 Hours
4.5	Types of additives in lubricants for improved tribological performance	1 Hour
4.6	Environmental aspects related to use and disposal of lubricating oils, recycling.	1 Hour
5	Module-5	7
5.1	Carburizing, Nitriding, Nitro-carburising, boriding, chromizing	2 Hours
5.2	PVD-CVD-Electrochemical deposition-Thermal spraying	2 Hours
5.3	Bearings-Classification of Bearings-Bearing materials-	1 Hour
5.4	Diagnostic maintenance of Tribological components	1 Hour
5.5	Maintenance of gear boxes, roller chains and wire ropes.	1 Hour

COURSE CODE	COURSE NAME	CATEGORY	L	T	P	CREDITS
22MEE802.6	MICRO AND NANO MANUFACTURING	PROGRAM ELECTIVE III	2	1	0	3

Preamble: This course serves to enable the learners to understand the underlying principles, processes and applications with regard to broader areas of micro manufacturing and nanotechnology. It also covers dimensional metrology aspects and tools for micro and nanoscale manufacturing.

Prerequisite: Nil

Course Outcomes: After the completion of the course the student will be able to:

CO 1	Explain different techniques used in micro and nano manufacturing
CO 2	Describe conventional techniques used in micro manufacturing.
CO 3	Describe non-conventional micro-nano manufacturing approaches.
CO 4	Outline the working principle and applications of micro and nano finishing processes
CO 5	Explain the basics of micro and nano fabrication techniques.
CO 6	Apply and select metrology systems in micro and nano manufacturing.

Mapping of course outcomes with program outcomes:

	PO 1	PO 2	PO 3	PO 4	PO 5	PO 6	PO 7	PO 8	PO 9	PO 10	PO 11	PO 12
CO 1	3	-	-	-	-	-	1	-	2	1	1	-
CO 2	2	-	-	-	-	-	1	-	2	1	1	-
CO 3	2	-	-	2	-	-	1	-	2	1	1	-
CO 4	3	-	-	-	-	-	1	-	2	1	1	-
CO 5	2	-	-	-	-	-	1	-	2	1	1	-
CO 6	3	-	-	-	1	-	2	-	2	1	2	1

Assessment Pattern

Bloom's Category	Continuous Assessment Tests		End Semester Examination (marks)
	1 (marks)	2 (marks)	
Remember	20	20	40
Understand	20	20	40
Apply	10	10	20
Analyse	-	-	-
Evaluate	-	-	-
Create	-	-	-

### Mark distribution

Total Marks	CIE	ESE	ESE Duration
150	50	100	3 hours

### Continuous Internal Evaluation Pattern

Attendance	: 10 marks
Continuous Assessment Test (2 numbers)	: 25 marks
Assignment/Quiz/Course project	: 15 marks

End Semester Examination Pattern: There will be two parts; Part A and Part B. Part A contains 10 questions with 2 questions from each module, having 3 marks for each question. Students should answer all questions. Part B contains 2 questions from each module, of which student should answer any one. Each question can have maximum 2 sub-divisions and carry 14 marks.

### Course Level Assessment Questions

#### Course Outcome 1 (CO1):

1. Explain different techniques used in micro and nano manufacturing.
2. Explain typical fabrication process for an Integrated Chip.
3. Describe 3 basic regimes of fabrication at microscale.

#### Course Outcome 2 (CO2):

1. Discuss application areas of micro-turned components.
2. Point out limitations and challenges of micro-extrusion process.
3. List out any 4 application areas of micro-milling process.

#### Course Outcome 3 (CO3):

1. How are micromolds designed?
2. Discuss the principle and process of micro-EDM.
3. Discuss the principle and process of micro-LBM.

#### Course Outcome 4 (CO4):

1. With the help of a suitable diagram, explain the principle of Magnetorheological finishing process.
2. Describe Magnetic Float Polishing.

3. Draw the schematic of Elastic Emission Machining and explain.

Course Outcome 5 (CO5):

1. Explain how an elastic stamp is manufactured using soft lithographic techniques.
2. Describe the structure and properties of CN tubes.
3. What are the different approaches to deposition of diamond in a CVD Diamond process. Explain.

Course Outcome 6 (CO6):

1. Explain Scanning white-light interferometry with the help of a suitable diagram.
2. Outline unique metrological challenges faced in micro-nano manufacturing?
3. Explain Scanning Electron Microscopy in detail.

Model Question Paper

MET464 MICRO AND NANOMANUFACTURING

Max. Marks: 100

Duration: 3 hours

Part–A

Answer all questions. Each question carries 3 marks

1. Define microgrinding.
2. Point out any 3 differences between macroturning and microturning.
3. Why are high speed air turbine spindles useful for micromachining?
4. What is hot embossing? Why is it particularly suited for manufacturing of optical components?
5. Draw the schematic of Chemical Mechanical Polishing process.
6. Illustrate the mechanism of material removal in Ion beam machining.
7. List out various materials used in semi-conductor industry.
8. Show by a schematic how an elastic stamp is manufactured using soft lithography?
9. Draw the schematic of typical scanning white light interferometry set up.
10. What are the merits and demerits of On-machine metrology?

Part–B

Answer one full question from each module.

Module I

11. Discuss in detail the design requirements of microturning machines. (14 marks)

OR

12. Discuss the outcomes of microgrinding of ceramic materials. (14 marks)

Module II

13. Discuss the Focused Ion Beam system. (14 marks)

OR

14. Discuss various methods available for manufacturing of micromolding tools. (14 marks)

Module III

15. Describe Magnetic float polishing with a neat diagram. (14 marks)

OR

16. Discuss the principles of MRAFF process with a suitable diagram. (14 marks)

Module IV

17. Explain how a Field effect transistor is fabricated by the process of soft lithography?  
(14 marks)

OR

18. Describe all properties of Carbon Nanotubes. (14 marks)

Module V

19. Explain the operation of scanning tunneling microscope. (14 marks)

OR

20. What is Atomic force microscope? Explain its modes of operation. (14 marks)

## Syllabus

### Module 1

Introduction to principles of micro and nano fabrication techniques- microfabrication of semiconductor devices-standard micro machining flow chart- basics of micro fabrication-manipulative techniques. Introduction to mechanical micro machining: Micro drilling-process, tools and applications, Micro turning- principle, process, tools and applications, Diamond micro turning- principle, process, tools and applications, Micro milling and Micro grinding-processes, tools and applications, Micro extrusion- principle, process and applications.

### Module 2

Introduction to Non-conventional micro-nano manufacturing: Abrasive Jet Micro-machining, WAJMM- principle, process and applications. Micro EDM, Micro WEDM, Micro EBM- principle, process and applications. Micro ECM, Micro LBM, Focused Ion Beams- process, principle and applications. Micro moulding processes: Injection moulding, Reaction injection moulding, hot embossing, injection compression moulding- micromolding tools-applications.

### Module 3

Introduction to micro-nano finishing processes: Magnetorheological Finishing (MRF) processes, Magneto-rheological Abrasive Flow Finishing (MRAFF) processes- Principle, equipment and applications- Force analysis for MRAFF process. Magnetic float polishing (MFP), Elastic Emission machining (EEM), Ion Beam Machining (IBM), Chemical Mechanical Polishing (CMP)- principle, equipment and applications

### Module 4

Introduction to Nano Fabrication: Nano fabrication using soft lithography- principle and applications. Introduction to Carbon nano materials- CN tubes- properties and applications. CN tube transistors-Diamonds- properties and applications- CVD Diamond technology- LIGA process. Laser micro welding- Electron Beam Micro welding.

### Module 5

Introduction to micro-nano inspection and metrology: Scanning electron microscopy, Scanning white light interferometry, Optical Microscopy, Scanning probe Microscopy, Scanning tunnelling microscopy, Confocal microscopy, Atomic force microscopy. Introduction to On-machine metrology.

## Text Books and References

1. Mark J. Jackson, Micro and Nanomanufacturing, Springer, 2007.
2. N.P.Mahalik, Micromanufacturing and nanotechnology, Springer, 2006.
3. Mark J. Jackson, Microfabrication and Nanomanufacturing, Taylor and Francis-CRC press, 2006.
4. V.K. Jain, Micromanufacturing Processes, Taylor and Francis- CRC press, 2012.

## Course Contents and Lecture Schedule

No.	Topic	No. of Lectures	COs
1.1	Introduction to micro-nano fabrication techniques- principles and evolution.	1	CO1
1.2	Overview of microfabrication of semiconductor devices- example- Integrated Chip.	1	CO1
1.3	Standard micro machining flow chart and basics of microfabrication-manipulative techniques.	2	CO1
1.4	Introduction to mechanical micro machining. Micro drilling-principle, process, description and applications.	1	CO2
1.5	Micro turning- principle, process, description and applications.	1	CO2
1.6	Diamond micro turning- principle, process, description and applications.	1	CO2
1.7	Micro milling and Micro grinding- principle, process, description and applications.	1	CO2 CO5
1.8	Micro grinding- principle, process, description and applications.	1	CO2
1.9	Micro extrusions- principle, process, description and applications.	1	CO2 CO5
2.1	Introduction to non-conventional micro-nano manufacturing- Abrasive jet micro machining, WAJMM- principle, process, description and applications.	2	CO3
2.2	Micro EDM, Micro WEDM, Micro EBM- process, principle, description and applications.	2	CO3
2.3	Micro ECM, Micro LBM- process, principle, description and applications.	1	CO3
2.4	Focused Ion Beams-process, principle and applications.	1	CO3
2.5	Micromolding process- Injection molding, reaction Injection molding-process, principle, description and applications.	1	CO3
2.6	Hot embossing, injection compression molding- description	1	CO3
2.7	Micromolding tools- applications.	1	CO3
3.1	Introduction to micro-nano finishing processes- magnetorheological finishing (MRF)- process, principle, description, application.	1	CO4
3.2	Magnetorheological abrasive flow finishing (MRAFF)- process, principle- Force analysis- description and applications.	1	CO4
3.3	Magnetic float polishing (MFP)- process, principle, description and applications.	1	CO4



3.4	Elastic emission machining (EEM), Ion beam machining (IBM)- process, principle, description and applications.	1	CO4
3.5	Chemical mechanical polishing (CMP)- process, principle, description and applications.	1	CO4
4.1	Introduction to Nanofabrication- Nanofabrication using soft lithography- principle and applications- examples- field effect transistor, elastic stamp.	1	CO5
4.2	Manipulative techniques- principle and description, applications.	1	CO5
4.3	Introduction to Carbon nano materials- CN tubes- properties and applications- CN tube transistors.	1	CO5
4.4	Diamonds- properties and applications- CVD diamond technology.	2	CO5
4.5	LIGA process.	1	CO5
4.6	Laser micro welding- Electron beam micro welding.	1	CO5
5.1	Introduction to micro-nano inspection and metrology- Scanning electron microscopy- principle and description.	1	CO6
5.2	Scanning white light interferometry- principle and description.	1	CO6
5.3	Optical microscopy- principle and description.	1	CO6
5.4	Scanning probe microscopy, Scanning tunnelling microscopy- principle, description and applications.	1	CO6
5.5	Confocal microscopy, Atomic force microscopy- principle and description.	1	CO6
5.6	Introduction to On-machine metrology.	1	CO6

COURSE CODE	COURSE NAME	CATEGORY	L	T	P	CREDITS
22MEE802.7	HEATING AND VENTILATION SYSTEMS	PROGRAM ELECTIVE III	2	1	0	3

Preamble: The objectives of the course are:

- The course aims at exposing the students to the areas of heating ventilation and air conditioning systems and their applications.
- The students will be capable to select suitable system for an application.
- The students will be equipped with the basic technical knowledge regarding the subject, present trends and sustainable practices.

Pre-requisite: MET473 Refrigeration and Air conditioning.

Course Outcomes: After the completion of the course the student will be able to

CO 1	Explain the quality of air to be supplied for comfort and healthy condition.
CO 2	Compare different HVAC systems for an application.
CO 3	Design a HVAC system by selecting suitable components and environmentally safe refrigerant.
CO 4	Evaluate the cooling load and capacity requirement of ac machine
CO 5	Design the duct for HVAC and make the drawing.

Mapping of course outcomes with program outcomes

	PO 1	PO 2	PO 3	PO 4	PO 5	PO 6	PO 7	PO 8	PO 9	PO 10	PO 11	PO 12
CO 1	1											1
CO 2	1											1
CO 3	3		3				3					1
CO 4	3	3	3	3								1
CO 5	3	3		3								1

Assessment Pattern

Bloom's Category	Continuous Assessment			End Semester Examination
	Assignment (%)	Test 1 (%)	Test 2 (%)	
Remember	25	20	20	10
Understand	25	40	40	20
Apply	25	40	40	70
Analyse	25			
Evaluate				
Create				

### Mark distribution

Total Marks	CIE	ESE	ESE Duration
150	50	100	3 hours

#### Continuous Internal Evaluation Pattern:

Attendance	: 10 marks
Continuous Assessment Test (2 numbers)	: 25 marks
Assignment/Quiz/Course project	: 15 marks

#### End Semester Examination Pattern:

There will be two parts; Part A and Part B. Part A contain 10 questions with 2 questions from each module, having 3 marks for each question. Students should answer all questions. Part B contains 2 questions from each module of which student should answer any one. Each question can have maximum 2 sub-divisions and carry 14 marks.

#### Course Level Assessment Questions

##### Course Outcome 1 (CO1):

1. What is the need of mixing return air to outdoor air?
2. Explain different types of air filters used and their specification?
3. Explain the % outdoor air requirements for different application?

##### Course Outcome 2 (CO2)

1. Explain VRF system and its advantages?
2. Explain terminal reheat system and its merits?
3. Explain all water system of refrigeration and its draw backs?

##### Course Outcome 3 (CO3):

1. Describe different types of refrigerants and their relative ODP and GWP?
2. Differentiate between scroll type compressor and reciprocating compressor?
3. What is cooling tower and explain its working principle?

##### Course Outcome 4 (CO4):

1. An Auditorium has seating capacity 800 people is to be maintained at 23°C DBT and 50% RH. The outdoor conditions are 40°C DBT and 27°C WBT. The various loads in the office are: Solar heat gain 10KW, sensible heat gain per occupant 80W, Latent heat per occupant 70W, Lighting load 5KW, Sensible heating load from other

sources 12KW, Infiltration load  $0.3\text{m}^3/\text{sec}$ . Outdoor air and return air is mixed in the ratio of 1: 6 ,before cooling coil (processing unit) and then supplied to room. The supply temperature cannot be lower than  $12^{\circ}\text{C}$  .find capacity of the plant required, mass flow rate of air.

2. What are ESR, ISEER, GSHF and RSHF? Explain.

3. Explain the method of basement ventilation Systems?

Course Outcome 5 (CO5):

1. What are the general aspects to be considered while designing a duct system?

2. Explain equal friction method of determination of duct size?

3. Write any five notations, legends, symbols used in HVAC drawing.

Model Question Paper

#### HEATING AND VENTILATION SYSTEMS–MET474

MAXIMUM: 100 MARKS

DURATION: 3 HOURS

#### PART A

Answer all questions. Each question carries 3 marks

1. What is HEPA filter? Where it is used?
2. What is the need of mixing return air to outdoor air??
3. What is the need of air water system of air conditioning system?
4. What is the difference between CAV and VAV system of air conditioning?
5. What are ODP and GWP of a refrigerant?
6. What are the disadvantages of hydrocarbon reorients?
7. What is IPLV of an ac system?
8. Explain the method of basement ventilation Systems?
9. Write any five notations, legends, symbols used in HVAC drawing.
10. What is throw of air?

(10 X 3 = 30 Marks)

## PART B

Answer one full question from each module

### MODULE 1

11. a. Explain the % outdoor air requirements for different application? 7 marks  
b. Explain comfort chart? How to locate comfort region for all-round air conditioning? 7 marks
12. a. Explain effective temperature? What are the factors effecting effective temperature? 7 marks  
b. Explain any two methods of dehumidification and represent it as line diagram in psychrometric chart. 7 marks

### MODULE II

13. a. Explain Dual duct system with the help of neat sketch? 7 marks  
b. Explain VRF system and its advantages over the conventional system? 7 marks
14. a. Explain all air system of air conditioning with the help of neat sketch? 7 marks  
b. Explain the air conditioning system suitable for an auditorium, restaurant and bed room with proper justifications? 7 marks

### MODULE III

15. a. Explain CFC, HCFC, and HFC, HC refrigerants with suitable examples and relative merits and demerits. 7 marks  
b. What are the methods to check leak and ensure capacity during commissioning of an ac system? 7 marks
16. a. Explain scroll type compressor with the help of a neat sketch? 7 marks  
b. What is the use of a cooling tower? Explain the working with the help of a neat sketch. 7 marks

### MODULE IV

17. a. An Auditorium has seating capacity 800 people is to be maintained at 23°C DBT and 50% RH. The outdoor conditions are 40°C DBT and 27°C WBT. The various loads in the office are: Solar heat gain 10KW, sensible heat gain per occupant 80W, Latent heat per occupant 70W, Lighting load 5KW, Sensible heating load from other sources 12KW, Infiltration load 0.3m<sup>3</sup>/sec. Outdoor air and return air is mixed in the ratio of 1: 6 ,before cooling coil (processing unit) and then supplied to room. The supply temperature cannot be lower than 12°C .find capacity of the plant required, mass flow rate of air. 10 marks  
b. Explain different thermal insulation materials used in ac system. 4 marks

18.a. Explain various heating loads in an auditorium? How infiltration load accounted while calculating RSHF 7 marks

b. explain bypass factor. Represent the bypass factor in a psychrometric chart for a cooling coil. 7 marks

MODULE V

19 a. A packaged air conditioner serves four rooms in an apartment. The schematic layout of the duct system together with the volume flow rate to each room is shown in Figure. The duct shall be of standard round sections. The air velocity in the first section is not to exceed 25 m/s. There is a pressure drop of 5 Pa at each of the outlet grilles at F,H,M and K. Assume the resistance due to the fittings as below. Assume pressure drop at Elbow 2 pa, pressure drop at Tee joint= 1Pa. Determine the size of the duct system using the equal-friction method. Estimate the static pressure drop in each line

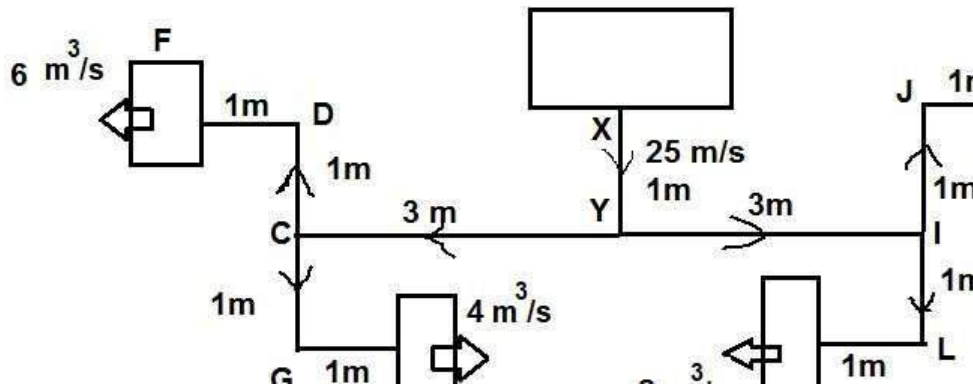

12 marks

b. What is spread of air? 2 marks

20 a. Explain Principles of air distribution. 7 marks

b. draw a simple drawing of an air conditioning system for a conference hall of seating capacity 50 people? 7 marks

## Syllabus

### Module 1- Introduction to HVAC

Importance of HVAC systems. Standard requirements of ventilation air for different applications. Air changes per hour -Conditions for comfort –comfort chart, effective temperature. Factors effecting effective temperature, Methods of dehumidification, humidification, and temperature control. Mixing of air stream. Type of air filters and their specification, HEPA filters.

### Module 2 Air conditioning systems.

Unitary system, window , split system, central station system, all air system, all water system, air-water system, VAV system , CAV systems Terminal reheat system, Dual duct system, Multi- zone system, Fan Coil units , relative merits and demerits – selection of particular system for an application. Cassette ac system. VRF system and inverter AC - relative merits.

### Module 3 Components of HVAC

Type of Compressors used- rotary, reciprocating, scroll type- cooling and heating coil. Environment friendly refrigerants.CFC, HCFC, HFC, HC refrigerants.Ozone depletion potential(ODP), global warming potential(GWP), use of boilers in HVAC, ducts, electrical systems for HVAC, air distribution system -types of outlets- diffusers- condensers, cooling tower, air handling unit, pumps, air dampers. Hot water generator and chilled condenser water piping. Testing and maintenance on ducts and pipes. Refrigerant leak detection methods.

### Module 4 Systems and Applications

Capacity determination of an ac machine. COP, EER, IEER, IPLV, star rating, specification of capacity TONs, HP, Cooling load calculation, sensible heat loads, latent heat loads, SHF, RSHF, GSHF, infiltration, bypass factor, Numerical examples. Methods to check the capacity during commissioning of new ac machine. Passive techniques to reduce cooling loads or heating loads in building. Insulation materials.

Basement ventilation Systems, Basement ventilation. Car park ventilation, Toilet, pantry ventilation.

### Module 5 Duct design

General consideration of duct design. Duct size determination. Equal friction method, balanced capacity method, Static regains method assumed velocity method. Location with due consideration for reduction of heat gain. Layout of supply and return air ducts. General considerations in air duct design layout. Throw of air, Spread of air, Entrainment ratio, Principles of air distribution, Sound and Vibration control techniques.

HVAC drawings, understanding notations, legends, symbols used in HVAC drawing.

### Text Books

1. Refrigeration and Air Conditioning, Arora C.P, Tata McGraw hill.
2. A Course in Refrigeration and air conditioning Arora S. C. and S. Domkundwar, Dhanpat Rai and Company. 2002
3. A text book of Refrigeration and air conditioning – R.K .Regiput, Katson books.
4. Refrigeration and air conditioning - Ahamadul Ameen Eastern economy addition.
5. Heating, Ventilating, and Air Conditioning: Analysis and Design, Faye C. Mcquiston, Jerald D. Parker, Jeffrey D. Spitler, John Wiley and sons. New York

### Data books

1. Refrigeration tables and charts including air conditioning data, C P Kothandaraman, New Age International.
2. Refrigeration and air conditioning data book, Domkunduwar and Domkundwar, Dhanpat Rai & co.

### Reference books

1. ASHRAE Handbook 201(Volume 1, 2, 3)
2. Principles of heating ventilation and air conditioning in building, john Dixon, Delmar learning
3. Analysis and design of heating ventilation and air conditioning system, Herbert W Stanford and Adam F spach, CRC press -Taylor and Francis.

### Course Contents and Lecture Schedule

MODULE	TOPICS	HOURS ALLOTTED
1	Importance of HVAC systems. Standard requirements of ventilation air for different applications. Air changes per hour	2-1-0
	Conditions for comfort –comfort chart, effective temperature. Methods of dehumidification, humidification, and temperature control. Mixing of air stream.	2-0-0
	Type of air filters and their specification, HEPA filters.	1-0-0
2	Unitary system, window , split system, central station system, all air system, all water system, air-water system, VAV system , CAV systems Terminal reheat system, Dual duct system, Multi-zone system, Fan Coil units , relative merits and demerits – selection of particular system for an application. Cassette ac system. VRF system and inverter AC - relative merits.	3-1-0
	Type of Compressors used- rotary, reciprocating, scroll type,	



3	cooling and heating coil. Environment friendly refrigerants.CFC, HCFC, HFC, HC refrigerants.Ozone depletion potential(ODP), global warming potential(GWP), use of boilers in HVAC, ducts, electrical systems for HVAC, air distribution system -types of outlets- diffusers- condensers, cooling tower, air handling unit, pumps, air dampers. Hot water generator and chilled condenser water piping. Testing and maintenance on ducts and pipes. Refrigerant leak detection methods.	4-2-0
4	Capacity determination of an ac machine. COP, EER, IEER, IPLV, star rating, specification of capacity TONs, HP, Cooling load calculation, sensible heat loads, latent heat loads, SHF, RSHF, GSHF, infiltration, bypass factor, Numerical examples	4-2-0
	Methods to check the capacity during commissioning of new ac machine. Passive techniques to reduce cooling loads or heating loads in building. Insulation materials.	2-1-0
	Basement ventilation Systems, Basement ventilation. Car park ventilation, Toilet, pantry ventilation.	2-0-0
5	General consideration of duct design. Duct size determination. Equal friction method, balanced capacity method, Static regains method assumed velocity method. Location with due consideration for reduction of heat gain. Layout of supply and return air ducts. General considerations in air duct design layout. Throw of air; Spread of air, Entrainment ratio, Principles of air distribution, Sound and Vibration control techniques.	3-1-0
	HVAC drawings, understanding notations, legends, symbols used in HVAC drawing. Simple drawing of a ac system for an auditorium and conference room	3-1-0

---

**SEMESTER VIII**

---

**PROGRAM ELECTIVE IV**

---



### Assessment Pattern

Bloom's Category	Continuous Assessment Tests		End Semester Examination
	1	2	
Remember	25	25	25
Understand	15	15	15
Apply	30	30	30
Analyse	10	10	10
Evaluate	10	10	10
Create	10	10	10

### Mark distribution

Total Marks	CIE	ESE	ESE Duration
150	50	100	3 hours

#### Continuous Internal Evaluation Pattern:

Attendance	: 10 marks
Continuous Assessment Test (2 numbers)	: 25 marks
Assignment/Quiz/Course project	: 15 marks

#### End Semester Examination Pattern:

There will be two parts; Part A and Part B. Part A contain 10 questions with 2 questions from each module and having 3 marks for each question. Students should answer all questions. Part B contains 2 questions from each module of which student should answer any one. Each question carries 14 marks and can have a maximum of 2 subdivisions.

#### Course Level Assessment Questions

##### Course Outcome 1 (CO1):

- 1 Explain about history of evolution of composites
- 2 Explain about the function of reinforcement and matrix in composite
- 3 Classify the composite according to type of matrix and reinforcement
- 4 What are the advantages and disadvantages of composites
- 5 Discuss about smart composites
- 6 Explain about types of bonding at interface
- 7 Explain about wettability of composites

##### Course Outcome 2 (CO2)

- 1 Compare between natural fibers and synthetic fibers
- 2 Explain the procedure of boron fiber fabrication
- 3 Explain Ex-Pan carbon fiber and Ex-Pitch carbon fiber fabrication
- 4 With neat sketched explain Ex-cellulose carbon fiber.
- 5 Discuss about aramid fiber fabrication
- 6 Explain whiskers with examples.

Course Outcome 3(CO3):

- 1 Discuss about thermoset, thermoplastic and elastomeric polymeric materials
- 2 Explain different hand lay methods
- 3 Explain different moulding methods for PMC

Course Outcome 4 (CO4):

- 1 How the metal matrix composites are classified
- 2 Explain the role of intermetallics in MMC
- 3 What are the properties, characteristics and applications of MMC
- 4 Explain different production techniques of MMC

Course Outcome 5 (CO5):

- 1 How CMC are classified and their potential role as matrices material.
- 2 What are the properties, characteristics and applications of CMC.
- 3 Explain conventional techniques for the production of CMC.
- 4 Explain maximum stress and strain criterion related to micromechanics of composites
- 5 Derive expression for Tsai-Hill and Tsai-Wu failure criterion.

Model Question Paper

APJ ABDUL KALAM TECHNOLOGICAL UNIVERSITY

EIGHTH SEMESTER B.TECH DEGREE EXAMINATION

Course Code : MET416

Course Name : COMPOSITE MATERIALS

Max. Marks : 100

Duration : 3 Hours

PART – A

(ANSWER ALL QUESTIONS, EACH QUESTION CARRIES 3 MARKS)

- 1) What are the conditions to be satisfied for a material to be called as a composite material.
- 2) Define wettability in fiber-matrix bonding and its importance in composite properties.
- 3) What are the important application of aramid fibers.
- 4) Write a short note on Boron fibers.
- 5) Compare thermosetting and thermoplastic matrix material.
- 6) List the function of components in pultrusion technique used in PMCs.

- 7) What are the modifications required in casting process for improving the properties of metal matrix composites.
- 8) Name the metals and their properties used in metal matrix composites.
- 9) With the aid of neat sketch explain lanxide process.
- 10) What are the different failure modes of fiber composites?

PART – B

(ANSWER ONE FULL QUESTION FROM EACH MODULE)

MODULE – 1

11. (a) Classify the composite materials based on the geometry of the reinforcement and matrix. ( 7 Marks)
- (b) Explain the different types of bonding interfaces in composites with sketches. ( 7 Marks )

OR

12. (a) What are the advantages of composite materials over the conventional engineering materials? (6 marks)
- (b) Explain about 1) Fiber pull out 2) Delamination 3) Fiber bridging 4) Debonding ( 8 Marks )

MODULE – 2

13. (a) How the carbon fibers are produced from PAN? (7 marks)
- (b) Describe the filament winding process in polymer matrix composites. (7 marks)

OR

14. (a) Explain different types of whiskers with examples. (7 marks)
- (b) Write a short note on wet jet spinning process for producing aramid fibers (7 marks)

MODULE – 3

15. (a) With neat sketch, explain the hand lay-up process? (7 marks)
- (b) With neat sketches explain manufacturing of laminated composite using prepreg (7 marks)

OR

16. (a) Explain the significance of various polymer materials used for PMC production? (7 marks)
- (b) With neat sketch, explain the bag moulding process? (7 marks)

MODULE – 4

17. (a) With neat sketches explain about In situ process by unidirectional solidification (7 marks)

(b) With the aid of neat sketch explain Squeeze casting method for MMC? (7 marks)

OR

18. (a) Explain application of precipitation-hardenable alloy materials used in the manufacture of metal matrix composites (7 marks)

(b) Write a short note about diffusion bonding. (7 marks)

MODULE – 5

19. (a) With neat sketches explain liquid infiltration process in ceramic matrix composites (7 marks)

(b) State and explain the maximum- stress theory for predicting the composite failure (7 marks)

OR

20. (a) Explain the in-situ chemical reaction techniques for CMC production? (7 marks)

(b) Describe the Tsai-Hill failure criteria for composites. (7 marks)

## SYLLABUS

### Module 1

Composite : Introduction, definition, characteristics, functions, classification of composites based on structure and matrix , smart composites, advantages and limitations, history, industrial scene and applications, Interfaces: wettability and bonding interface in composites. types of bonding at interface.

### Module 2

Fibers : Introduction, types of fibers, natural fibers, glass fiber fabrication, structure, properties and applications, boron fiber fabrication, structure, properties and applications, carbon fiber, Ex-Pan carbon fiber, Ex cellulose carbon fiber, Ex-Pitch carbon, carbon fiber structure, properties and applications, aramid fiber fabrication, structure, properties and applications, whiskers: characteristics, properties and applications.

### Module 3

Polymer matrix composites (PMC) : thermoset, thermoplastic and elastomeric polymers, properties, characteristics and applications as matrix materials, processing of polymer matrix composites: hand methods, Lay up method, spray up method, moulding methods, pressure bagging and bag moulding methods, Autoclave-based processing with prepregs, pultrusion and filament winding process.

### Module 4

Metal matrix composites (MMC) : classification of metals, intermetallics, alloys and their potential role as matrices in composites, properties, characteristics and applications of metals as matrix materials, production techniques: powder metallurgy, diffusion bonding, melt stirring, squeeze casting, liquid infiltration under pressure, insitu process.

### Module 5

Ceramic matrix composites (CMC) : classification of ceramics and their potential role as matrices, properties, characteristics and applications of ceramics as matrix materials, conventional techniques : cold pressing and sintering, hot pressing, reaction bonding, liquid infiltration, pultrusion. lanxide process, insitu chemical technique, sol-gel technique, Micromechanics of composites: maximum stress and strain criterion (derivations only). Tsai-Hill and Tsai-Wu failure criterion (derivations only). mechanics of load transfer from matrix to fiber (description)

### Text Books

1. K. K. Chawla, Composite Materials : Science and Engineering, Springer, 3e, 2013.
2. P.K.Mallicak, Fiber-reinforced composites , Monal Deklar Inc., New York, 1988.
3. Reddy J N (Ed.), Mechanics of Composite Materials; Selected Works of Nicholas J. Pagano, Springer, 1994
4. Robert M. Jones, Mechanics of Composite Materials, CRC Press, 1998



## Reference Books

1. F.L.Matthews & R.D.Rawlings, Composite Materials, Engineering and Sciences, Chapman & hall, London, 1994
2. Hand Book of Composites, George Lubin. Van Nostrand, Reinhold Co. 1982
3. Micael hyer, Stress Analysis of Fiber - Reinforced Composite Materials , Tata McGraw Hill, 1998.

## Course Contents and Lecture Schedule:

No	Topic	No of lectures + Tutorial
1	Module 1: Introduction to composites	7 hours
1.1	Composite : Introduction, definition, characteristics, functions	1L
1.2	Classification of composites based on structure and matrix: History, industrial scene and applications	1L
1.3	Smart composites, advantages and limitations	1L+1L
1.4	Interfaces: wettability and bonding interface in composites	1L
1.5	Types of bonding at interface.	1L + 1T
2	Module 2: Types of fibers/ whiskers used in composites	7 hours
2.1	Fibers : Introduction, types of fibers, natural fibers	1L
2.2	Fiberization, stabilization, carbonization, graphitization, glass fiber Fabrication, structure, properties and applications	1L
2.3	Boron fiber fabrication, structure, properties and applications	1L
2.4	Carbon fiber, Ex-Pan carbon fiber, Ex-Pitch carbon, Ex cellulose carbon fiber	1L + 1T
2.5	Aramid fiber fabrication, structure, properties and applications	1L
2.6	Whiskers: characteristics, properties and applications.	1L
3	Module 3: Polymer matrix composites	6 hours
3.1	Polymer matrix composites (PMC) : thermoset, thermoplastic and Elastomeric polymers	1L
3.2	Properties, characteristics and applications as matrix materials	1L
3.3	Processing of polymer matrix composites: hand methods, Lay up method, spray up method	1L
3.4	Moulding methods, pressure bagging and bag moulding methods, Autoclave-based processing with prepregs	1L + 1T
3.5	Pultrusion and filament winding process.	1L

4	Module 4: Metal matrix composites	7 hours
4.1	Classification of metals, intermetallics, alloys and their potential role as matrices in composites	2L
4.2	Properties, characteristics and applications of metals as matrix materials	1L
4.3	Production techniques: powder metallurgy, diffusion bonding, melt stirring	1L + 1T
4.4	Squeeze casting, liquid infiltration under pressure, insitu process.	1L + 1T
5	Module 5: Ceramic matrix composites & Micromechanics of composites	8 hours
5.1	Classification of ceramics and their potential role as matrices	1L
5.2	Properties, characteristics and applications of ceramics as matrix materials	1L
5.3	Conventional techniques : cold pressing and sintering, hot pressing, Reaction bonding, liquid infiltration, pultrusion.	1L
5.4	Lanxide process, insitu chemical technique, sol-gel technique	1L
5.5	Micromechanics of composites: maximum stress and strain criterion (derivations only)	1L + 1T
5.6	Tsai-Hill and Tsai-Wu failure criterion (derivations only)	1L
5.7	Mechanics of load transfer from matrix to fiber (description only)	1L

COURSE CODE	COURSE NAME	CATEGORY	L	T	P	CREDITS
22MEE803.2	ARTIFICIAL INTELLIGENCE AND MACHINE LEARNING	PROGRAM ELECTIVE IV	2	1	0	3

Preamble: This course is specifically designed for Mechanical Engineers to get acquainted with essential mathematical concepts, brush up on their statistics and the fundamentals of ML and AI

Prerequisite: NIL

Course Outcomes: After the completion of the course the student will be able to

CO Nos	Course Outcomes	Level of learning domain
CO 1	Illustrate the basic mathematics of artificial intelligence and Machine learning	2
CO 2	Explain the concepts of artificial intelligence	2
CO 3	Explain machine learning techniques and computing environment that are suitable for the applications under consideration	2
CO 4	Develop scaling up machine learning techniques and associated computing techniques and technologies for various applications	3
CO 5	Explain data analytics and Machine learning Applications	2

Mapping of course outcomes with program outcomes

	PO 1	PO 2	PO 3	PO 4	PO 5	PO 6	PO 7	PO 8	PO 9	PO 10	PO 11	PO 12
CO 1	3	2			2							1
CO 2	3	2			2							1
CO 3	3	2			2							1
CO 4	3	2			2							1
CO 5	3	2			2							1

Assessment Pattern

Bloom's Category	Continuous Assessment Tests		End Semester Examination
	1	2	
Remember			
Understand	40	40	70
Apply	10	10	30
Analyse			
Evaluate			
Create			

## Mark distribution

Total Marks	CIE	ESE	ESE Duration
150	50	100	3 hours

### Continuous Internal Evaluation Pattern:

Attendance	: 10 marks
Continuous Assessment Test (2 numbers)	: 25 marks
Assignment/Quiz/Course project	: 15 marks

End Semester Examination Pattern: There will be two parts; Part A and Part B. Part A contain 10 questions with 2 questions from each module, having 3 marks for each question. Students should answer all questions. Part B contains 2 questions from each module of which student should answer any one. Each question can have maximum 2 sub-divisions and carry 14 marks.

### Course Level Assessment Questions

#### Course Outcome 1 (CO1):

1. Define Maximum error estimate
2. Define simple correlation and write formula for simple correlation coefficient
3. Write the expression for the control line and three sigma for mean Chart

#### Course Outcome 2 (CO2)

1. What is Artificial Intelligence?
2. Application of Artificial Intelligence
3. Explain about neural networks?

#### Course Outcome 3(CO3):

1. Machine learning concepts with examples.
2. Discuss supervised and unsupervised learning?
3. Write a program using python

#### Course Outcome 4 (CO4):

1. Explain KNN?
2. What is web scraping?
3. Discuss about Natural Language processing

#### Course Outcome 5 (CO5):

1. What are the benefits of Data science for Mechanical Engineers?
2. Explain about Numpy and pandas
3. Write about the potential applications of Machine learning in manufacturing sector?

Model Question Paper

MET 426 - ARTIFICIAL INTELLIGENCE AND MACHINE LEARNING

Max. Marks : 100

Duration : 3 Hours

Part – A

Answer all questions, each question carries 3 marks

1. Define Maximum error estimate
2. Write the normal equations for the least square curve of the form  $y = ab^x$
3. What are the Problem Characteristics of Artificial Intelligence?
4. What is a Rule based programming?
5. Define machine learning.
6. Discuss any four examples of machine learning applications
7. Write down the major differences between K-means clustering and hierarchical clustering
8. Explain the different string formats available in Python with examples
9. What is data science and its benefits?
10. What are the goals of data science?

PART -B

Answer one full question from each module.

MODULE – 1

11. Find moment generating function for binomial distribution and hence find its mean and variance (14 marks)

OR

12. Samples of size 2 are taken from the population 4,8,12,16,20,24 with replacement. Find
- a) The mean of the population
  - b) The standard deviation of the population
  - c) Mean of the sampling distribution of means
  - d) The standard deviation of the sampling distribution of mean. (14 marks)

MODULE – 2

13. Give details of the year-wise development of AI. How AI is being used in the area of Mechanical engineering research (14 marks)

OR

14. (a) Differentiate between the various learning methods: neural networks, reinforcement learning and genetic algorithm (8 marks)
- (b) What are the various heuristic techniques .Explain how they are different from the solution guaranteed techniques (6 marks)

MODULE – 3

15. Distinguish between supervised learning and Reinforcement learning. Illustrate with an example (14 marks)

OR

16. (a) Write a program to print the sum of the following series  $1 + 1/2 + 1/3 + \dots + 1/n$  (8 marks)
- b) Explain the need for continue and break statements. Write a program to check whether a number is prime or not. Prompt the user for input. (6 marks)

MODULE – 4

17. Explain about web scraping and discuss about the possibility of usage (14 marks)

OR

18. (a) Explain about Semantic Analysis? (4 marks)

b) What do you understand by Natural Language Processing? List any two real-life applications of Natural Language Processing. (10 marks)

MODULE – 5

19. (a) Illustrate with an example different stages of data science project. (8 marks)

b) How the AI technology used in automobile industry (6 marks)

OR

20. Explain the importance of Machine learning concepts in manufacturing sector (14 marks)

Syllabus

Module 1

Fundamentals of probability and statistics – Probability theory- sample and population – statistical interference – random process – logical relations – conditional probability – density function – distributions – regressions – parametric estimation – non parametric – statistical test.

Module 2

Introduction to artificial intelligence - Typical Applications, Keras API, Artificial Neural Networks (ANNs): Concept, Activation Functions, Feed Forward Neural Networks and Back Propagation-Working of CNN, Convolutional Layer, Pooling, Flatten, Image recognition techniques and feature Extraction fundamentals

Module 3

Machine learning: Introduction, Types of Machine Learning: Supervised, Unsupervised and Reinforcement learning, Applications, Classification vs Prediction Problems, Linear Regression Algorithm, Python Basics – string, number, list, tuple, Dictionary, functions, conditional statement, Loop statements, simple programming exercises using python

Module 4

Introduction to KNN (K Nearest Neighbor), Working of KNN, Decide the value of K, Confusion Matrix, Accuracy Score, Web Scraping Basics- Need of Web Scraping, Natural Language Processing: Introduction, Stages in natural language Processing, Application of NLP in Real world applications

Module 5

Introduction to Data Science, Flow of Data Science, Numpy, Pandas, Matplotlib. Machine Learning Applications across Industries.

## Text Books

1. T.K.V. Iyengar “Probability & Statistics”, S.Chand (G/L) & Company Ltd, 2008
2. Schalkoff, R.J., “Artificial Intelligence: An Engineering Approach”, McGraw-Hill, 1990
3. Stuart Russell and Peter Norvig, “Artificial Intelligence: A modern approach”. Prentice Hall, New Jersey, 1995
4. Ethem Alpaydin, Introduction to Machine Learning, 2nd edition, MIT Press 2010
5. Tom Mitchell, Machine Learning, McGraw-Hill, 1997

## Reference Books

1. Nilson, N. J., “Principles of Artificial Intelligence”, Springer Verlag, Berlin, 1980
2. Eugene Charniak and Drew McDermot, “Introduction to Artificial Intelligence”, Addison Wesley Longman Inc., 1998
3. Trevor Hastie, Robert Tibshirani, Jerome Friedman, The Elements Of Statistical Learning, Second edition Springer 2007
4. Shai Shalev-Shwartz and Shai Ben-David., Understanding Machine Learning , Cambridge University Press. 2017

## Course Contents and Lecture Schedule

No	Topic	No. of Lectures
MODULE 1		
1.1	Probability theory- sample and population – statistical interference	2
1.2	random process – logical relations	2
1.3	conditional probability – density function – distributions	2
1.4	Parametric estimation – non parametric – statistical test.	1
MODULE 2		
2.1	Introduction to artificial intelligence - Typical Applications	1
2.2	Keras, API	1
2.3	Artificial Neural Networks (ANNs): Concept, Activation Functions	2
2.4	Feed Forward Neural Networks and Back Propagation-	1
2.5	Working of CNN, Convolutional Layer, Pooling, Flatten, Image recognition techniques	2
MODULE 3		
3.1	Machine learning: Introduction	1
3.2	Supervised, Unsupervised and Reinforcement learning,	2
3.3	Classification vs Prediction Problems, Linear Regression Algorithm	2
3.4	Python Basics, simple programming exercises using python	2
MODULE 4		
4.1	Introduction to KNN (K Nearest Neighbor), Working of KNN	2

4.2	Confusion Matrix, Accuracy Score	2
4.3	Web Scraping Basics- Need of Web Scraping	2
4.4	Natural Language Processing: Introduction, Stages in natural language Processing	1
MODULE 5		
5.1	Introduction to Data Science	2
5.2	Flow of Data Science	2
5.3	Numpy, Pandas, Matplotlib	2
5.4	Machine Learning Applications across Mechanical Industries	2



COURSE CODE	COURSE NAME	CATEGORY	L	T	P	CREDITS
22MEE803.3	ACOUSTICS AND NOISE CONTROL	PROGRAM ELECTIVE IV	2	1	0	3

Preamble: Course objectives:

- To understand the principles of acoustics.
- To give awareness about different acoustic measurement instruments and analysis equipment.
- To introduce the importance of noise control
- To give awareness about regulations and standards related to noise exposure.

Prerequisite: Nil

Course Outcomes: After the completion of the course the student will be able to

CO No.	Course Outcomes	Level of learning domain
CO 1	Explain various acoustic terminologies and understand the physics behind acoustic wave propagation	2
CO 2	Evaluate reflection and transmission coefficients in sound transmission through different media and understand the concept of standing waves	5
CO 3	Explain the mechanism of hearing, concept of noise, various noise criteria and standards	2
CO 4	Explain different noise measures and various noise measurement devices	2
CO 5	Apply noise control measures to different machines and devices	3

Mapping of course outcomes with program outcomes

	PO 1	PO 2	PO 3	PO 4	PO 5	PO 6	PO 7	PO 8	PO 9	PO 10	PO 11	PO 12
CO 1	3	3	2									
CO 2	3	3	3			3						
CO 3	3	3	2			3	3					
CO 4	3	3	2			3						
CO 5	3	3	3			3	3					

### Assessment Pattern

Bloom's Category	Continuous Assessment Tests		End Semester Examination
	1	2	
Remember			
Understand	20	20	30
Apply	20	20	50
Analyse			
Evaluate	10	10	20
Create			

### Mark distribution

Total Marks	CIE	ESE	ESE Duration
150	50	100	3 hours

### Continuous Internal Evaluation Pattern:

Attendance	: 10 marks
Continuous Assessment Test (2 numbers)	: 25 marks
Assignment/Quiz/Course project	: 15 marks

End Semester Examination Pattern: There will be two parts; Part A and Part B. Part A contain 10 questions with 2 questions from each module, having 3 marks for each question. Students should answer all questions. Part B contains 2 questions from each module of which student should answer any one. Each question can have maximum 2 sub-divisions and carry 14 marks.

### Course Level Assessment Questions

#### Course Outcome 1 (CO1):

1. Derive acoustic wave equation. Deduce the equation for plane acoustic wave
2. Describe about Acoustic impedance, Energy density and Sound intensity.
3. a) Discuss about different 'levels' of sound measurement  
 b) A harmonic plane wave is propagating with frequency 35 Hz in air at room temperature. The acoustic pressure at a point 1.5 m from the sound source at a time 2 s from the instant of observation is 0.2 Pa. Find the acoustic pressure at the same point at 4 s.

### Course Outcome 2 (CO2)

1. Describe about spherical waves, beam width and directivity index.
2. Sound wave is propagating from a fluid medium of density  $\rho_1$  to a fluid medium of density  $\rho_2$  at an angle of incidence  $\theta_i$ . Speed of sound in first medium is  $c_1$  and that in second medium is  $c_2$ . Obtain the pressure reflection and pressure transmission coefficient.
3. There was some concern that over-water flights of the supersonic transport would harm marine life. A plane sound wave from the aircraft in air ( $\rho = 1.1\text{kg/m}^3$ ,  $c = 347\text{ m/s}$ ) has a sound pressure of 140 dB. The sound wave strikes the surface of the sea water ( $\rho = 1022\text{kg/m}^3$ ,  $c = 1500\text{ m/s}$ ) normally. Determine the intensity of the transmitted wave in sea water and the magnitude of the rms acoustic pressure of the transmitted wave

### Course Outcome 3(CO3):

1. With the help of a neat sketch explain the hearing mechanism in human beings
2. a) Describe about speech interference level and perceived noise level  
b) Explain about threshold of hearing
3. Describe about any two noise standards

### Course Outcome 4 (CO4):

1. Brief about sound level meter and dosimeter
2. a) Explain about the working of noise analyser  
b) What are microphones?
3. How sound is measured in a reverberation chamber and in an anechoic chamber

### Course Outcome 5 (CO5):

1. Explain about absorption coefficient. What are acoustic absorbers? Brief about any one type of acoustic absorber
2. a) Suggest some measures to control the noise produced by sound source.  
b) How noise can be controlled in reciprocating machines?
3. What are possible causes for noise in a rotating machinery? Explain some measures to control such noise

Model Question Paper

EIGHTH SEMESTER B. TECH DEGREE  
EXAMINATION Course Code: MET436  
Course Name: ACOUSTICS AND NOISE CONTROL

Max. Marks: 100

Duration: 3 Hours

PART – A

(Answer all questions, each question carries 3 marks)

1. What are plane acoustic waves?
2. Explain about sound pressure level?
3. A fan alone produces a sound intensity level of 80 dB. A pump and a fan together produce an intensity level of 86.2 dB. Determine the intensity level of the sound produced by the pump.
4. What are Helmholtz resonators?
5. Describe about plenum chambers.
6. Discuss about phon.
7. How standing waves are generated?
8. Brief about spherical waves
9. Describe about frequency weighting
10. Discuss about Number noise index

PART – B

(ANSWER ONE FULL QUESTION FROM EACH MODULE)

Module – 1

11. a) Derive acoustic wave equation. Deduce the equation for plane acoustic wave  
(9 Marks)  
b) A harmonic plane wave is propagating with frequency 35 Hz in air at room temperature. The acoustic pressure at a point 1.5 m from the sound source at a time 2 s from the instant of observation is 0.2 Pa. Find the acoustic pressure at the same point at 4 s.  
(5 Marks)
12. a) Elaborate about particle velocity and phase velocity  
(4 Marks)  
b) Obtain the D'Alembert's solution of plane acoustic wave equation  
c) Calculate the speed of sound in air having a density of  $1.225 \text{ kg/m}^3$  and pressure of 101 kPa. Take the adiabatic constant as 1.44.  
(3 Marks)

Module 2

13. a) A plane wave is incident at the boundary between air and helium at 20 degree C. Given that at 20degree C air density is  $1.2041 \text{ kg/m}^3$  , speed of sound in air is 343

m/s, helium density is  $0.179 \text{ kg/m}^3$  and speed of sound in helium is  $972 \text{ m/s}$ . Find the reflection coefficient, transmission coefficient and absorption coefficient (7 marks)

b) Brief about beam width and directivity index. (5 Marks)

c) What are resonators? (2 Marks)

14. a) Obtain the pressure reflection and pressure transmission coefficient for the oblique incidence of sound on a medium boundary. (10 marks)

b) Obtain the acoustic pressure developed in a pipe of length  $L$  whose one end is closed. Sound source is a vibrating piston attached to the open end of the pipe.

(4 Marks)

### Module 3

15. a) With suitable figure, explain the hearing mechanism in human ear. (8 Marks)

b) With suitable example describe about perceived noise level and speech interference level (6 Marks)

16. a) Human react differently to different sounds. With suitable instances describe about human reactions to various sounds and noises (8 Marks)

b) Brief about OSHA noise exposure criteria (6 Marks)

### Module 4

17. a) Brief about reverberation chambers and anechoic chambers. Describe in detail about how measurements are done in them (10 marks)

b) Explain the working of dosimeter (4 Marks)

18. a) With the help of a neat diagram, explain the working of sound level meter (8 marks)

b) What are microphones. Brief about any one type (6 marks)

### Module 5

19. a) Describe about (8 Marks)

(i) Mufflers

(ii) Acoustic filters

b) Brief about acoustic absorbers (6 Marks)

20. a) What are bafflers. Explain how noise reduction is attained through baffler (7 Marks)

b) Discuss the ways by which noise produced by rotating machines can be controlled (7 marks)

## Syllabus

### Module 1

Introduction – Basic acoustic principles, sound pressure, acoustic velocity, particle velocity, acoustic wave equation, Plane acoustic wave, harmonic solution.

Frequency, wavelength, acoustic impedance, sound power, sound intensity, Energy density, Decibel scale – relationship between pressure, intensity and power

### Module 2

Spherical waves – radiation – simple source – hemispherical source- radiating piston – pressure intensity distribution – Beam width and directivity index

Transmission through one, two and three media – Transmission through pipes – branched and unbranched, resonators – Transmission loss- reflection at plane surface, standing waves, standing wave apparatus.

### Module 3

Ear its structure and function, Hearing Thresholds, Loudness of Sound, and Sound Adaptation, Human reaction to sound – definitions of speech interference level, perceived noise level, phon and sone, hearing loss. Noise criteria and standards – noise and number index guide lines for designing quieter equipments

### Module 4

Noise measurement- microphones, sound level meters, sound intensity probes, dosimeters, noise analyzer and graphic level recorder, spectrum Analysis, Measurement in anechoic and reverberation chambers

### Module 5

Principles of noise control, control at source, during transmission and at receiver- protection of receiver, Acoustic insulation – acoustic materials – acoustic filter and mufflers – plenum chamber, advanced acoustic absorbers

Principles of noise control in machinery such as pumps, rotating machines, reciprocating machines etc

### Text Books

1. Kinsler and frey – Fundamentals of Acoustics
2. I. L. Ver, L. L. Beranek– Noise and Vibration Control Engineering
3. Grad – Industrial noise and vibration

### Reference Books

1. Malcom J Crocker , Handbook of noise and vibration control, John Wiley & Sons, Inc.

2. Heinrich Kuttruff, Acoustics an introduction, Taylor & Francis
3. David-A Bies. Collin H Hansen, Engineering Noise control- Theory and Practice, Fourth edition, Spon press, London
4. Michael Moser, Engineering Acoustics, Springer

#### Course Contents and Lecture Schedule

No	Topic	No. of Lectures
1	Module 1	
1.1	Introduction – Basic acoustic principles, sound pressure, acoustic velocity, particle velocity	1
1.2	Acoustic wave equation, Plane acoustic wave, harmonic solution	3
1.3	Frequency, wavelength, acoustic impedance, sound power, sound intensity, Energy density, Decibel scale – relationship between pressure, intensity and power	3
2	Module 2	
2.1	Spherical waves – radiation – simple source – hemispherical source- radiating piston – pressure intensity distribution – Beam width and directivity index	1
2.2	Transmission through one, two and three media	3
2.3	Transmission through pipes – branched and unbranched, resonators – Transmission loss- reflection at plane surface, standing waves, standing wave apparatus.	3
3	Module 3	
3.1	Ear its structure and function, Hearing Thresholds, Loudness of Sound, and Sound Adaptation	2
3.2	Human reaction to sound – definitions of speech interference level, perceived noise level, phon and sone, hearing loss	2
3.3	Noise criteria and standards – noise and number index guide lines for designing quieter equipments	3
4	Module 4	
4.1	Noise measurement- microphones, sound level meters, sound intensity probes, dosimeters, noise analyzer and graphic level recorder, spectrum Analysis	5
4.2	Measurement in anechoic and reverberation chambers	3
5	Module 5	
5.1	Principles of noise control, control at source, during transmission and at receiver- protection of receiver, Acoustic insulation –	4

	acoustic materials – acoustic filter and mufflers – plenum chamber, advanced acoustic absorbers	
5.2	Principles of noise control in machinery such as pumps, rotating machines, reciprocating machines etc	3



COURSE CODE	COURSE NAME	CATEGORY	L	T	P	CREDITS
22MEE803.4	HEAT TRANSFER EQUIPMENT DESIGN	PROGRAM ELECTIVE IV	2	1	0	3

Preamble: The course is designed to provide a complete design knowledge of various heat transfer equipments which are invariably used in most of the chemical process industries.

Prerequisite: MET204 Thermodynamics, MET302 Heat and Mass Transfer

Course Outcomes: After the completion of the course the student will be able to

CO 1	Analyse thermal performance of heat exchangers
CO 2	Explain performance of cooling towers
CO 3	Design heat pipes for different applications

Mapping of course outcomes with program outcomes

	PO 1	PO 2	PO 3	PO 4	PO 5	PO 6	PO 7	PO 8	PO 9	PO 10	PO 11	PO 12
CO 1	✓	✓	✓									
CO 2	✓	✓	✓									
CO 3	✓	✓	✓									

Assessment Pattern

Bloom's Category	Continuous Assessment Tests		End Semester Examination
	1	2	
Remember	10	10	20
Understand	30	30	60
Apply	10	10	20
Analyse			
Evaluate			
Create			

Mark distribution

Total Marks	CIE	ESE	ESE Duration
150	50	100	3 hours

#### Continuous Internal Evaluation Pattern:

Attendance	: 10 marks
Continuous Assessment Test (2 numbers)	: 25 marks
Assignment/Quiz/Course project	: 15 marks

End Semester Examination Pattern: There will be two parts; Part A and Part B. Part A contain 10 questions with 2 questions from each module, having 3 marks for each question. Students should answer all questions. Part B contains 2 questions from each module of which student should answer any one. Each question can have maximum 2 sub-divisions and carry 14 marks.

#### Course Level Assessment Questions

##### Course Outcome 1 (CO1):

1. How double pipe heat exchangers are classified
2. Explain the concept of true temperature difference in a 1-2 heat exchanger.

##### Course Outcome 2 (CO2)

1. Illustrate and explain the functions of cooling tower.
2. Explain briefly how performance evaluation of cooling towers are done .

##### Course Outcome 3(CO3):

1. Explain the working principle of heat pipes
2. Explain briefly the heat pipe design procedure.

Model Question Paper

EIGHTH SEMESTER B.TECH DEGREE EXAMINATION

COURSE CODE: MET446

COURSE NAME: HEAT TRANSFER EQUIPMENT DESIGN

Max. Marks: 100

Duration: 3 Hours

PART – A

(Answer all questions, each question carries 3 marks)

1. What do you mean by compact heat exchanger and write the importance of area density in it.
2. Under what condition, the effectiveness NTU method is preferred over LMTD method as a method of analysis of Heat exchanger.
3. Are we really getting extra advantage by providing Baffles in Shell and tube heat exchanger. Justify your answer.
4. What are the causes of pressure drop in shell and tube heat exchanger?
5. How size of cooling tower and wet bulb temperature are related?
6. How do you calculate evaporation loss in cooling tower?
7. Explain the term liquid pressure drop as applicable to heat pipes
8. How effective thermal conductivity of a wick structure is determined ?
9. How heat pipes work against gravity ?
10. Write short notes on micro heat pipes.

PART – B

(Answer one full question from each module)

MODULE – 1

11. a) How fouling is dealt while designing heat exchangers. ( 4 Marks )

b) A counter-flow double-pipe heat exchanger is to heat the cold fluid from 30°C to 65°C at a rate of 2 kg/s. The heating is to be accomplished by hot fluid available at 100°C at a mass flow rate of 1 kg/s. The inner tube is thin-walled and has a diameter of 1.5 cm. Specific heat of the hot fluid is 10kJ/kgK and that of the cold fluid is 5 kJ /kgK. If the overall heat transfer coefficient of the heat exchanger is 640 W/m<sup>2</sup> °C, determine the length of the heat exchanger required to achieve the desired heating. (10 Marks )

OR

12 a) Derive the effectiveness of counter flow heat exchanger ( 8 Marks )

b) What would be the effectiveness of counter flow heat exchanger if  $C_{min}/C_{max} = 0$  and  $C_{min}/C_{max}=1$  (6 Marks)

MODULE – 2

13. The condenser of a large steam power plant is a heat exchanger in which steam is condensed to liquid water. Assume the condenser to be a shell-and-tube heat exchanger consisting of a single shell and 30,000 tubes, each executing two passes. The tubes are of thin wall construction with  $D=25$  mm, and steam condenses on their outer surface with an associated convection coefficient of  $h_0=11,000$  W/m.K the heat transfer rate that must be effected by the exchanger is  $q=2 \times 10^9$  W , and this is accomplished by passing cooling water through the tubes at a rate of  $3 \times 10^4$  kg/sec. the water enters at  $20^\circ\text{C}$  while the steam condenses at  $50$  degree C. What is the temperature of the cooling water emerging from the condenser? What is the required tube length L per pass? ( 14 Marks)

OR

14. a) Draw rough sketch of temperature distribution curve for condenser and evaporator type heat exchangers. Derive the expression for overall heat transfer coefficient for shell and tube type heat exchanger (7 marks)

b) A heat exchanger is to be designed to condensate  $8$  kg/s of an organic liquid having saturation temperature  $800^\circ\text{C}$  and  $h_{fg} = 600$ kJ/kg. Cooling water is available at  $150^\circ\text{C}$  and at a flow rate of  $60$  kg/s. The overall heat transfer co-efficient is  $480$  W/m<sup>2</sup> -K. Determine: (1) The number of tubes required if tubes are to be  $2$ mm thick,  $4.85$  m in length and  $25$ mm OD. (2) No.s of tube passes if limiting velocity of cooling water is  $2$  m/s. (7 marks)

MODULE – 3

15. a) Explain different types of cooling towers (8 marks)

b) Explain the terms a) Cooling range b) Approach and c) Effectiveness as applied to a cooling tower (6 marks)

OR

16. a) Write about the importance of wet bulb temperature in cooling towers? (7 marks)

b) What is the effect of change in heat load on cooling tower performance? Explain. (7 marks)

MODULE – 4

17. Write short notes on a ) Working fluids b ) Wick Structures as applicable to heat pipes? (14 marks)

OR

18. Explain briefly capillary, sonic, entrainment and boiling limitations applied to heat pipes  
(14 marks)

#### MODULE – 5

19. Explain how fluid selection, wick selection and material selection are done in a heat pipe design.  
(14 marks)

OR

20. Write brief notes on Non conventional heat pipes  
(14 marks)

#### Syllabus

##### Module 1

Thermal performance analysis of heat exchangers - compact, cross flow, liquid to gas, and double pipe heat exchangers, film coefficients for tubes and annuli, equivalent diameter of annuli, fouling factors, caloric or average fluid temperature, true temperature difference; Design calculation of double pipe heat exchanger, double pipe exchangers in series-parallel arrangements.

##### Module 2

Shell and tube heat exchangers - tube layouts, baffle spacing, classification of shell and tube exchangers, Design calculation of shell and tube heat exchangers, shell-side film coefficients, shell-side equivalent diameter, true temperature difference in a 1-2 heat exchanger, performance analysis of 1-2 heat exchangers, flow arrangements for increased heat recovery.

##### Module 3

Direct contact heat transfer - Classification of cooling towers, wet-bulb and dew point temperatures, Lewis number, cooling-tower internals, heat balance, heat transfer by simultaneous diffusion and convection; Design and analysis of cooling towers, determination of the number of diffusion units, performance evaluation of cooling towers, influence of process conditions and operating variables on their design .

##### Module 4

Heat pipes - types and applications, operating principles, working fluids, wick structures, control techniques, pressure balance, maximum capillary pressure, liquid and vapor pressure drops, effective thermal conductivity of wick structures, capillary limitation on heat transport capability, sonic, entrainment, and boiling limitations, determination of operating conditions

##### Module 5

Heat pipe design – fluid selection, wick selection, material selection, preliminary design considerations, heat pipe design procedure, determination of heat pipe diameter, design of heat pipe containers, wick design, entrainment and boiling limitations, design problems;

Non conventional heat pipes – flat, rotating, reciprocating and disc shaped heat pipes, heat pipes in cooling microelectronics – micro and mini heat pipes.

#### Text Books

- 1 Kern, D. Q., Process Heat Transfer, Tata McGraw-Hill, 2000.
2. Chi, S. W., Heat Pipe Theory and Practice- A Source Book, McGraw-Hill, 1976
3. Fraas, A. P., Heat Exchanger Design, Second Edition, John Wiley & Sons, 1989

#### Reference Books

1. R K Shah, Fundamentals of Heat Exchanger Design, John Wiley & Sons.
2. Dunn, P. D. and Reay, D. A., Heat Pipes, Fourth Edition, Pergamon Press, 1994.
3. Das, S.K., Process heat transfer, Narosa publishing house.2005

#### Course Contents and Lecture Schedule

No	Topic	No. of Lectures
1.1	Thermal performance analysis of heat exchangers - compact, cross flow, liquid to gas, and double pipe heat exchangers,	2
1.2	Film coefficients for tubes and annuli, equivalent diameter of annuli, fouling factors, caloric or average fluid temperature, true temperature difference; Design calculation of double pipe heat exchanger	3
1.3	Double pipe exchangers in series-parallel arrangements.	2
2.1	Shell and tube heat exchangers - tube layouts, baffle spacing, classification of shell and tube exchangers, Design calculation of shell and tube heat exchangers, shell-side film coefficients, shell-side equivalent diameter, true temperature difference in a 1-2 heat exchanger,	4
2.2	performance analysis of 1-2 heat exchangers, flow arrangements for increased heat recovery.	3
3.1	Direct contact heat transfer - Classification of cooling towers, wet-bulb and dew point temperatures, Lewis number, cooling-tower internals, heat balance, heat transfer by simultaneous diffusion and convection;	3
3.2	Design and analysis of cooling towers, determination of the number of diffusion units, performance evaluation of cooling towers, influence of process conditions and operating variables on their design .	4
4.1	Heat pipes - types and applications, operating principles, working fluids, wick structures, control techniques, pressure balance, maximum capillary pressure, liquid and vapor pressure drops, effective thermal conductivity of wick structures,	3
4.2	capillary limitation on heat transport capability, sonic,	3

	entrainment, and boiling limitations, determination of operating conditions	
5.1	Heat pipe design – fluid selection, wick selection, material selection, preliminary design considerations, heat pipe design procedure, determination of heat pipe diameter, design of heat pipe containers, wick design, entrainment and boiling limitations,	5
5.2	design problems; Non conventional heat pipes – flat, rotating, reciprocating and disc shaped heat pipes, heat pipes in cooling microelectronics – micro and mini heat pipes.	3

COURSE CODE	COURSE NAME	CATEGORY	L	T	P	CREDITS
22MEE803.5	ROBOTICS AND AUTOMATION	PROGRAM ELECTIVE IV	2	1	0	3

Preamble: The objective of this course is

- To know the wide applications of Robotic technology in various domains
- To familiarize various robot sensors and their perception principles that enable a robot
- To get a basic understanding about the kinematics and dynamics of robot.

Course Outcomes: After the completion of the course the student will be able to

CO 1	Explain the concept, development and key components of robotics.
CO 2	Apply the mathematics used to describe positions and orientations in space.
CO 3	Solve numerical problems in the statics and dynamics of robotic models.
CO 4	Explain various robot sensors and their perception principles.

Mapping of course outcomes with program outcomes

	PO 1	PO 2	PO 3	PO 4	PO 5	PO 6	PO 7	PO 8	PO 9	PO 10	PO 11	PO 12
CO 1	3	3	3									2
CO 2	3	3	3									2
CO 3	3	3	3									2
CO 4	3	3	3									2

Assessment Pattern

Bloom's Category	Continuous Assessment Tests		End Semester Examination
	1	2	
Remember			
Understand	30	30	60
Apply	20	20	40
Analyse			
Evaluate			
Create			

Mark distribution

Total Marks	CIE	ESE	ESE Duration
150	50	100	3 hours



#### Continuous Internal Evaluation Pattern:

Attendance	: 10 marks
Continuous Assessment Test (2 numbers)	: 25 marks
Assignment/Quiz/Course project	: 15 marks

End Semester Examination Pattern: There will be two parts; Part A and Part B. Part A contain 10 questions with 2 questions from each module, having 3 marks for each question. Students should answer all questions. Part B contains 2 questions from each module of which student should answer any one. Each question can have maximum 2 sub-divisions and carry 14 marks.

#### Course Level Assessment Questions

##### Course Outcome 1 (CO1):

1. Describe the major elements of an industrial robot.
2. What is work volume?
3. Compare pneumatic drive robots with stepper motor drive robot.

##### Course Outcome 2 (CO2)

1. Define base and tool coordinate systems.
2. Determine the translated vector for the given vector  $v=25i+10j+20k$ , perform a translation by a distance of 8 units in "X" direction, 5 units in "Y" direction and 0 units in "Z" direction.
3. Explain any two commands associated with the programming of end effectors.

##### Course Outcome 3 (CO3):

1. Describe briefly the dynamics of a robot.
2. A single-link robot with a rotary joint is motionless at  $\theta=-50$  . It is desired to move the joint in a smooth manner to  $\theta = 80^\circ$  in 4 seconds. Find the coefficients of a cubic which accomplishes this motion and brings the arm to rest at the goal.
3. Write a critical note on forward kinematics of a 2 degrees of freedom robot.

##### Course Outcome 4 (CO4):

1. Differentiate between the sensor & transducer.
2. Explain the working principle of inductive proximity sensor.
3. What are the applications of machine vision system?

Model Question Paper

Max. Marks: 100

Duration: 3 Hours

PART A (30 marks)

*Answer all questions, each carries 3 marks.*

1. Briefly explain the need of robots in healthcare.
2. Explain the working of a UAV.
3. Differentiate between open and closed kinematic chain with the help of examples.
4. What is the difference between internal grippers and external grippers?
5. Define the singularities of a mechanism.
6. How will you obtain the dynamic model of a robot?
7. Explain the need of mapping in the kinematics of robots.
8. What is trajectory planning in robotics?
9. Briefly explain the function of a LVDT.
10. What are the applications of machine vision system?

PART B (70 marks)

*Answer any one question from each module, each carries 14 marks.*

*Module 1*

11. a) Classify the industrial robots and briefly describe it. (7)  
b) Explain the various parts of a robot with neat sketch. (7)
12. a) Explain the working of DC servo motors used in robotics. (7)  
b) Discuss about the salient features of servo motor with limitations. (7)

*Module 2*

13. a) Explain RRR and RPR mechanism. (8)  
b) Explain actuator space, joint space and Cartesian space of a manipulator. (6)
14. Explain the different types of frames used in robot motion. (14)

*Module 3*

15. a) What are the four parameters in DH representation? Explain how they are determined? (8)
- b) If the two links of a two-link planar manipulator have equal lengths, find out the expression for the homogeneous transformation matrix. (6)
16. Illustrate the forward and reverse kinematics of a robot with an example. (14)

*Module 4*

17. Obtain equations of dynamics for 2-R manipulator using lagrangian method. (14)
18. a) Explain the propagation of velocity from link to link in a manipulator. (8)
- b) Explain the joint space and cartesian space descriptions of robot trajectory (6)

*Module 5*

19. a) Describe the classification of sensors and the factors to be considered for its selection. (7)
- b) Describe force sensing with strain gauge and wrist force sensor. (7)
20. a) Explain the segmentation methods used in vision system with suitable example. (7)
- b) Describe any one algorithm for image edge detection with advantages. (7)

## Syllabus

### Module 1 (7 hours)

Introduction: History and evolution of Robotics, Industrial Robots, Field and Service Robots, Wheeled Mobile Robots, Underwater Robots, remotely operated vehicles, Autonomous Underwater Vehicle, Robotics for Healthcare, Rehabilitation Robotics, Aerial Robotics, Domestic Robots. Components of a Robot: Mechanical systems, Electrical systems. Robot drive systems: Pneumatic Drives – Hydraulic Drives – Mechanical Drives – Electrical Drives – D.C. Servo Motors, Stepper Motor, A.C. Servo Motors – Salient Features. Applications.

### Module 2 (7 hours)

Spatial description and Transformations: Description of Position and Orientation, Rotation matrix, Euler angles, Frames and Displacement mappings, Homogeneous transforms, Transformation of free vectors.

Robot Manipulator: Manipulator joints- linear and rotary, Types. Link description, Link-connection description. Robot architecture, Convention for affixing frames to links, reference frames, degree of freedom. Common body and arm configurations in industrial robots- Cartesian, polar, cylindrical, jointed arm, SCARA. Wrist assembly- end effector, Mechanical gripper.

### Module 3 (7 hours)

Robot Kinematics: Robot Coordinates- global and tool coordinates. Link and joint parameters Denavit and Hartenberg convention, DH algorithm. Typical examples of forward and Inverse Kinematics problem.

General considerations in trajectory description and generation: joint-space schemes, Cartesian-space schemes.

### Module 4 (7 hours)

Robot statics: motion of the links of a robot, velocity propagation from link to link, geometric Jacobian, Jacobian computation, kinematic singularities, static forces in manipulators, Jacobians in the force domain, Cartesian transformation of velocities and static forces.

Robot Dynamics: manipulator dynamic equations, Lagrangian formulation of manipulator dynamics, dynamical model of simple manipulator structures.

### Module 5 (7 hours)

Sensors and machine vision: Requirements of a sensor, Principles and Applications of the following types of sensors – Position of sensors (Piezo Electric Sensor, LVDT, Resolvers, Optical Encoders), Range Sensors (Triangulation Principle, Structured, Lighting Approach, Laser Range Meters).

Proximity Sensors (Inductive, Capacitive and Ultrasonic), Touch Sensors, (Binary Sensors, Analog Sensors), Wrist Sensors, Compliance Sensors, Slip Sensors. Camera, Frame Grabber, Sensing and Digitizing Image Data – Signal Conversion, Image Storage, Lighting Techniques.

### Text/Reference Books

1. Craig, J.J., Introduction to Robotics: Mechanics and Control, Pearson Education India; 3<sup>rd</sup> edition ,2008.
2. M.P.Groover, Industrial Robotics – Technology, Programming and Applications, McGraw-Hill, 2001.
3. Fu.K.S., Gonzalz.R.C. and Lee C.S.G., Robotics Control, Sensing, Vision and Intelligence, McGraw-Hill Book Co., 1987
4. Janakiraman.P.A., Robotics and Image Processing, Tata McGraw-Hill, 1995.

### Course Contents and Lecture Schedule

No	Topic	No. of Lectures
1	Introduction to robotics	
1.1	History and evolution of Robotics, Industrial Robots, Field and Service Robots.	1
1.2	Wheeled Mobile Robots, Underwater Robots, remotely operated vehicles, Autonomous Underwater Vehicle	1
1.3	Robotics for Healthcare, Rehabilitation Robotics	1
1.4	Aerial Robotics, Domestic Robots. Components of a Robot: Mechanical systems, Electrical systems.	1
1.5	Pneumatic Drives – Hydraulic Drives –Mechanical Drives – Electrical Drives	1
1.6	D.C. Servo Motors, Stepper Motor	1
1.7	A.C. Servo Motors	1
2	Robot Manipulator	
2.1	Spatial description and Transformations: Description of Position and Orientation, Rotation matrix, Euler angles.	1
2.2	Frames and Displacement mappings, Homogeneous transforms.	1
2.3	Transformation of free vectors.	1
2.4	Robot Manipulator: Manipulator joints- linear and rotary, Types. link description, link-connection description.	1
2.5	Robot architecture, convention for affixing frames to links, reference frames, degree of freedom.	1
2.6	Common body and arm configurations in industrial robots- cartesian, polar, cylindrical, jointed arm, SCARA.	1
2.7	Wrist assembly-end effector, Mechanical gripper.	1
3	Robot Kinematics	
3.1	Global and tool coordinates. Link and joint parameters.	1
3.2	Denavit and Hartenberg convention.	1

3.3	DH algorithm.	1
3.4	Examples of forward Kinematics of planar robots.	1
3.5	Inverse manipulator kinematics. Solvability. Algebraic vs Geometric Solutions	1
3.6	Inverse Kinematics of RR and RP planar manipulators	1
3.7	General considerations in trajectory description and generation: joint-space schemes, cartesian-space schemes	1
4	Robot Statics and Dynamics	
4.1	Motion of the links of a robot, velocity propagation from link to link,	1
4.2	Geometric Jacobian, Jacobian computation	1
4.3	Kinematic singularities	1
4.4	Static forces in manipulators, Jacobians in the force domain.	1
4.5	Cartesian transformation of velocities and static forces.	1
4.6	Lagrangian formulation of manipulator dynamics.	1
4.7	Dynamical model of 2 DOF planar manipulators	1
5	Sensors and machine vision system	
5.1	Requirements of a sensor, Piezo Electric Sensor, LVDT, Resolvers, Optical Encoders.	1
5.2	Range Sensors, Triangulation Principle, Structured, Lighting Approach, Laser Range Meters.	1
5.3	Proximity Sensors-Inductive, Capacitive and Ultrasonic.	1
5.4	Touch Sensors, (Binary Sensors, Analog Sensors), Wrist Sensors, Compliance Sensors, Slip Sensors.	1
5.5	Camera, Frame Grabber.	1
5.6	Sensing and Digitizing Image Data – Signal Conversion.	1
5.7	Image Storage, Lighting Techniques.	1

COURSE CODE	COURSE NAME	CATEGORY	L	T	P	CREDITS
22MEE803.6	TECHNOLOGY MANAGEMENT	PROGRAM ELECTIVE IV	2	1	0	3

Preamble: Management of innovation and technology is important an organisation. This course is designed to facilitate the students to understand the concept of technology management, Key issues in managing technology. This course will also help the students to gain a fair understanding on contemporary topics in technology and innovation management.

Prerequisite: NIL

Course Outcomes: After the completion of the course the student will be able to

CO 1	Be conversant with important terms for technology management in organisations
CO 2	Explain the need of technology forecasting
CO 3	Understand the essence of technology acquisition
CO 4	Describe the elements of technology strategy
CO 5	Outline the basics of innovation
CO 6	Identify human factors in technology management

Mapping of course outcomes with program outcomes

	PO 1	PO 2	PO 3	PO 4	PO 5	PO 6	PO 7	PO 8	PO 9	PO 10	PO 11	PO 12
CO 1	3					2					2	1
CO 2	2		2								2	2
CO 3	2					2						2
CO 4	3					2						2
CO 5	3					2					2	2
CO 6	2					2						2

Assessment Pattern

Bloom's Category	Continuous Assessment Tests		End Semester Examination (in %)
	1 (in %)	2 (in %)	
Remember	20	20	20
Understand	60	40	40
Apply	20	40	40
Analyse			
Evaluate			
Create			

## Mark distribution

Total Marks	CIE Marks	ESE Marks	ESE Duration
150	50	100	3 hours

### Continuous Internal Evaluation Pattern:

Attendance : 10 marks

Continuous Assessment Test (2 numbers) : 25 marks

Assignment/Quiz/Course project : 15 marks

End Semester Examination Pattern: There will be two parts; Part A and Part B. Part A contain 10 questions with 2 questions from each module, having 3 marks for each question. Students should answer all questions. Part B contains 2 questions from each module of which student should answer any one. Each question can have maximum 2 sub-divisions and carry 14 marks.

### Course Level Assessment Questions

#### Course Outcome 1 (CO1):

1. Distinguish between process technology and product technology
2. What are the impacts of technology on society?
3. Describe the significance of technology management.

#### Course Outcome 2 (CO2)

1. Describe the need of technology forecasting.
2. List out technology forecasting methods.
3. Describe characteristics of technology forecasting.

#### Course Outcome 3(CO3):

1. What is technology acquisition?
2. With examples, describe the process of managing acquired technology.
3. Describe the importance of technology generation.

#### Course Outcome 4 (CO4):

1. What are the constraints in technology absorption?
2. What are elements of technology strategy?



3. Describe the science and technology policy in India

Course Outcome 5 (CO5):

1. Differentiate between invention and innovation.
2. Describe the importance of innovation in product lifecycle
3. Enumerate the importance of trademarks.

Course Outcome 6 (CO6):

1. Explain the challenges of automation in India
2. What are the HR issues in R&D?
3. What are the different organisational factors to be considered in technology management.

Model Question Paper

EIGHTH SEMESTER B.TECH DEGREE

EXAMINATION

COURSE CODE: MET466      COURSE NAME: TECHNOLOGY MANAGEMENT

Max. Marks: 100

Duration: 3 Hours

PART A

Answer ALL questions, each carries 3 marks.

1. Describe the impact of technology in competition
2. Distinguish between process technology and product technology
3. What is technology acquisition?
4. Describe the need of technology forecasting.
5. How technology absorption improves competitiveness?
6. Describe the benefits of technology absorption
7. How is R&D affects production costs?
8. Describe the role of government in innovation.
9. How does organisational structure affect technology?
10. What are the HR issues in R&D?

PART B

11. What are the elements of technological innovation? Explain with examples (14)  
OR
12. Enumerate the impact of technology on society (14)
13. Describe characteristics of technology forecasting. (14)

OR

14. With examples, describe the process of managing acquired technology. (14)

15. Describe the constraints in technology absorption (14)

OR

16. What are the different elements of science and technology policy in India (14)

17. With the aid of examples, describe how innovation helps new product development (14)

OR

18. What are the different remedial measures against infringement (14)

19. Describe various human factors to be considered in technology management. (14)

OR

20. Describe the challenges of automation in India. (14)

## Syllabus

### Module 1

Technology and Technology Management - Technology- evolution and growth of technology, technology management: concepts and definitions, role and significance of technology management, impact of technology on society and business. Technology and competition, organizing technology at the enterprise level, key issues in managing technological innovation and forms of technology- process technology, product technology.

### Module 2

Technology Acquisition and Technology Forecasting - Technology acquisition, new technology, alternatives for acquiring new technologies, management of acquired technology, technology forecasting, characteristics of technology forecasting, technology forecast methods, principles of technology forecasting, technology forecasting process, need and role of technology forecasting, forecasting methods and techniques, planning and forecasting. Technology generation and development, technology generation, process, technology development, importance of technology generation and development.

### Module 3

Technology strategy and management - Need for technology strategy, technology adoption, diffusion, absorption and competitiveness, elements of technology strategy, role of technology absorption, benefits of technology absorption, constraints in technology absorption, technology package and technological dependence, Indian experience in technology absorption efforts, issues involved in the management of technology absorption and government initiatives, technology policies, science and technology policy in India.

## Module 4

Management of R&D and innovation - Importance of Research and Development (R&D), corporate research and product lifecycle, production costs and R&D, translation of R&D efforts to technology, innovation, types of innovation, difference between innovation and invention, framework for management of innovation, organizational characteristics that facilitate innovation, trademarks, copyrights, patents and their use in innovation management, remedy against infringement, the role of technology transfer in innovation and new product development, role of government in innovation, globalisation and innovations, technology and innovation management - case studies about management of R&D and innovation.

## Module 5

Human Aspects in Technology Management - Integration of people and technology, human factors to be considered in technology management - organisational factors and psychological factors, organisational structure and technology, implications of technological change, implementation of rationalization and automation in India, impact of technological change, human resource management issues in R&D and innovation, technology assessment and environmental impact analysis

### Text Books

1. P N Rastogi, Management of Technology and Innovation: Competing Through Technological Excellence, SAGE Publications, 2009
2. Tushman, M.L. and Anderson ,P., Managing Strategic Innovation & Change, Oxford University Press, New York, 2004.
3. Khurana, V. K., Management of Technology and Innovation, Ane Books New Delhi, 2012
4. Narayanan, V. K, Managing Technology and Innovation for Competitive Advantage, Pearson Education, 2002
5. Ettile, J. E, Managing Innovation: New technology, New Products and New Services in a Global Economy, A Butterworth-Heinemann Title, 2006

### Reference Books

1. Afuah, A, Innovation Management, Strategies, Implementation and Profits, Oxford University Press, 2009
2. Paul Trott, Innovation Management and New Product Development, Pearson Education, 2004.
3. Robert A Burgelman, Clayton.M.Christensen, Steven.C.Wheelright, Strategic Management of Technology and Innovation (Fifth Edition), McGraw-Hill Education, 2009

## Course Contents and Lecture Schedule

No	Topic	No. of Lectures
1	Technology and Technology Management	
1.1	Technology- evolution and growth of technology	1
1.2	Technology management: concepts and definitions, role and significance of technology management	1
1.3	Impact of technology on society and business. technology and competition, organizing technology at the enterprise level	2
1.3	Key issues in managing technological innovation	1
1.3	Forms of technology- process technology, product technology.	1
2	Technology Acquisition and Technology Forecasting	
2.1	Technology acquisition, new technology, alternatives for acquiring new technologies, management of acquired technology	2
2.2	Technology forecasting, characteristics of technology forecasting, technology forecast method, principles of technology forecasting, technology forecasting process, need and role of technology forecasting, forecasting methods and techniques, planning and forecasting.	3
2.3	Technology generation and development, technology generation-process, technology development, importance of technology generation and development.	2
3	Technology strategy and management	
3.1	Need for technology strategy, technology adoption, diffusion, absorption and competitiveness, elements of technology strategy	2
3.2	Role of technology absorption, benefits of technology absorption, constraints in technology absorption, technology package and technological dependence, Indian experience in technology absorption efforts.	3
3.3	Issues involved in the management of technology absorption, government initiatives, technology policies - science and technology policy in India.	2
4	Management of R&D and Innovation	
4.1	Importance of Research and Development (R&D), corporate research and product lifecycle, production costs and R&D, translation of R&D efforts to technology.	2
4.2	Innovation, types of innovation, difference between innovation and invention,	2
4.3	Framework for management of innovation, organizational characteristics that facilitate innovation,	1
4.4	Trademarks, copyrights, patents and their use in innovation	1

	management, remedy against infringement,	
4.5	The role of technology transfer in innovation and new product development, role of government in innovation, globalisation and innovations, technology and innovation management.	2
4.6	Case studies about management of R&D and innovation.	1
5	Human Aspects in Technology Management	
5.1	Integration of people and technology, factors to be considered in technology management, organisational factors and psychological factors	2
5.2	Organisational structure and technology, implications of technological change	2
5.3	Implementation of rationalization and automation in India, impact of technological change	1
5.4	Human resource management issues in R&D and innovation, technology assessment and environmental impact analysis	2

COURSE CODE	COURSE NAME	CATEGORY	L	T	P	CREDITS
22MEE803.7	CRYOGENIC ENGINEERING	PROGRAM ELECTIVE IV	2	1	0	3

Preamble: This course provides fundamental knowledge of types of cryogenic fluids, behavior of materials and properties at temperatures, liquefaction systems, cryogenic refrigeration, gas separation, purification, insulators, cryogenic storage, transfer and measuring instruments

Prerequisite: MET202-Engineering Thermodynamics, MET303-Thermal Engineering

Course Outcomes :After completion of the course the student will be able to

CO1	Explain the properties of cryogenic liquids and properties of material at cryogenic temperatures
CO2	Describe and analyze cryogenic liquefaction systems using first principles of thermodynamics
CO3	Describe and analyze cryogenics refrigeration using first principles of thermodynamics
CO4	Identify insulation system for cryogenic application and explain cryogenic storage vessels.
CO5	Understand gas separation and purification methods
CO6	Understand instrumentation for various measurements in cryogenic engineering.

Mapping of course outcomes with program outcomes

	PO 1	PO 2	PO 3	PO 4	PO 5	PO 6	PO 7	PO 8	PO 9	PO 10	PO 11	PO 12
CO 1	3	2	1									
CO 2	3	2										
CO 3	3	2	1									
CO 4	3	1										
CO 5	3	1										

Assessment Pattern

Bloom's Category	Continuous Assessment Tests		End Semester Examination (in %)
	1 (in %)	2 (in %)	
Remember	10	10	10
Understand	20	20	20
Apply	20	20	70
Analyse			
Evaluate			
Create			

### Mark distribution

Total Marks	CIE Marks	ESE Marks	ESE Duration
150	50	100	3 hours

### Continuous Internal Evaluation Pattern:

Attendance	: 10 marks
Continuous Assessment Test (2 numbers)	: 25 marks
Assignment/Quiz/Course project	: 15 marks

End Semester Examination Pattern: There will be two parts; Part A and Part B. Part A contain 10 questions with 2 questions from each module, having 3 marks for each question. Students should answer all questions. Part B contains 2 questions from each module of which student should answer any one. Each question can have maximum 2 sub-divisions and carry 14 marks.

### Course Level Assessment Questions:

#### Course Outcome 1 (CO1):

1. Describe in detail the variation of mechanical properties of various materials at cryogenic temperatures
2. Explain the terms i) Transition temperature and ii) Critical current of superconductors.
3. Explain the application of cryogenics in space technology.

#### Course Outcome 2 (CO2):

1. Explain the production of low temperatures using Joule-Thomson effect.
2. How the cryo coolers are classified? Explain the working of strilling cycle cryo cooler.
3. Explain about the working of a precooled Linde-Hampson system with suitable diagram for neon and hydrogen.

#### Course Outcome 3 (CO3):

1. Explain the working of Vuilleumier refrigerator with neat sketch.
2. Explain briefly the importance of refrigerator effectiveness.
3. Explain refrigerators using solids as working media.

#### Course Outcome 4 (CO4):

1. Explain about the basic design parameters of cryogenic fluid storage vessels.
2. Explain the different types and use of insulations in cryogenic applications.
3. Explain about the cryogenic fluid transfer system.

Course Outcome 5 (CO5):

1. Explain the pressure measurement system used in cryogenic applications.
2. Explain the working principle of different types of cryogenic liquid level indicators.
3. Explain different temperature measuring techniques used in cryogenic applications.

Model Question Paper

VIII SEMESTER B.TECH DEGREE EXAMINATION

MET476: CRYOGENIC ENGINEERING

Maximum: 100 Marks

Duration: 3 hours

PART A

Answer all questions, each question carries 3 marks

1. Explain the historical development of cryogenics?
2. Distinguish between Ortho Hydrogen and Para Hydrogen.
3. Explain Meissner effect?
4. Explain Joule Thomson coefficient.
5. What are the performance parameters to be considered in gas liquefaction systems?
6. Define FOM for the refrigerator.
7. What is vapour shielding in cryogenic vessels?
8. What are super insulations?
9. Write a short note on hydrostatic liquid level gauge.
10. List few heat exchangers used in cryogenic systems.

(10 X 3 = 30 marks)

PART B

Answer one full question from each module

Module 1

11. a) What is cryogenics? Mention the few areas involving cryogenic engineering  
(7 marks)  
b) Determine the thermal conductivity of air at 250 K and 101.3 kPa if the mean free path of air at this condition is 49 nm, the gas constant for air is 287 J/kg K, the specific heat ratio is 1.4 and the specific heat at constant volume is 716.5 J/kg K.  
(7 marks)
12. a) With sketches, explain the different critical components present in gas liquefaction systems.  
(7 marks)



- b) With the help of a T-s diagram explain working of a Simon Helium liquefier. (7 marks)

#### Module 2

13. a) Compare Claude Liquefaction system and Linde Hampson Liquefaction systems. (4 marks)  
b) Explain the Joule Thomson effect. Show the inversion curve of a real gas on a T-p diagram.  
Prove that an ideal gas will not experience a temperature change upon isenthalpic expansion. (10 marks)
14. a) With sketches, explain the different critical components present in gas liquefaction systems. (7 marks)  
b) With the help of a T-s diagram explain working of a Simon Helium liquefier. (7 marks)

#### Module 3

15. a) Explain the working of a dilution refrigerator with neat schematic. (7 marks)  
b) With the help of schematic and T-S diagram, explain Philips Refrigerator. Also explain briefly the importance of refrigerator effectiveness. (7 marks)
16. a) What are the gas purification methods? With sketches, explain adsorption purifier along with refrigerator purifier. (7 marks)  
b) With sketches, explain Linde single column gas separation system. (7 marks)

#### Module 4

17. a) With sketches, explain the cryogenic fluid storage vessels. (7 marks)  
b) Write about vacuum insulation and opacified powder insulation used in cryogenics. (7 marks)
18. a) Explain about cryogenic fluid transfer systems. (7 marks)  
b) With Sketch, explain the functions of different components in a Dewar vessel. (7 marks)

#### Module 5

19. a) Explain the working of a turbine flow meter. (7 marks)  
b) Write short notes on the various heat exchanger configurations used in cryogenic systems. (7 marks)

20. a) Explain the different temperature measurement techniques used in cryogenic application (7 marks)
- b) Explain different safety devices used in cryogenic liquid storage systems. (7 marks)

## Syllabus

### Module 1

Introduction to cryogenic engineering, Historical background - Major events in the development of cryogenic engineering, Low Temperature properties of Engineering Materials - Mechanical properties- Thermal properties- Electric and magnetic properties, Cryogenic fluids and their properties.

Applications of cryogenics: Applications in space, food processing, super conductivity, electrical power, biology, medicine, electronics and cutting tool industry.

### Module 2

Liquefaction systems – System performance parameters, ideal liquefaction system, Joule-Thomson expansion, Adiabatic expansion, Liquefaction systems for gases other than Neon. Hydrogen and Helium. Simple Linde - Hampson system, Claude & Cascaded System.

Liquefaction systems for Neon. Hydrogen and Helium – LN<sub>2</sub> precooled Linde Hampson and Claude systems, Ortho to Para conversion arrangement in hydrogen liquefaction system, Simon Helium liquefaction system, Collins Helium liquefaction system. Critical components of Liquefaction systems – critical components and their effect on system performance.

### Module 3

Cryogenic Refrigeration systems: Ideal isothermal and isobaric refrigeration systems- Refrigeration using liquids as refrigerant- Linde-Hampson refrigerator, Claude refrigerator. Refrigeration using gases as refrigerant- Stirling cycle cryocoolers, Philips refrigerator, Effect of regenerator effectiveness on performance of Philips refrigerator, Gifford McMahon refrigerators. Refrigerators using solids as working media-Magnetic refrigerators – Thermodynamics of magnetic refrigerators, dilution refrigerators.

### Module 4

Gas separation and purification: - Thermodynamic ideal separation system, mixture characteristics, principle of gas separation, separation of air, hydrogen and helium, gas purification methods

Cryogenic fluid storage and transfer systems:, Cryogenic fluid storage vessel, Thermal insulation and their performance at cryogenic temperatures, Super Insulations, Vacuum insulation, Powder insulation, Cryogenic fluid transfer systems, Cryo pumping.

### Module 5

Cryogenic instrumentation, Pressure measurement – McLeod gauge, Pirani gauge and Penning gauge, Flow measurement – Orifice meter, Venturi meter and Turbine flow meter. Liquid level gauges- hydrostatic, resistance gauge,, capacitance gauge and

thermodynamic gauge, Temperature measurements- ITS-90, Thermocouple, RTD, magnetic thermometers and vapor pressure thermometers, Types of heat exchangers used in cryogenic systems, Safety in cryogenic fluid handling, storage and use.

**Text Books:**

1. Randal F. Barron, Cryogenic systems, McGraw Hill, 1986
2. M Mukhopadhyay, Fundamentals of Cryogenic Engineering, PHI Learning , 2010
3. K. D. Timmerhaus and T. M. Flynn, Cryogenic Process Engineering, Springer, 2013
4. S.S Thipse, Cryogenics, Narrosa, 2012

**Reference Books:**

1. A. R. Jha, Cryogenic Technology and applications, Elsevier Science, 2011
2. R. B. Scott, Cryogenic Engineering, Van Nostrand Co., 1989
3. M. D. Atrey (Ed.) Cryocoolers: Theory and Applications, 1st ed., International Cryogenics Monograph Series, Springer International Publishing, 2020

**Course Contents and Lecture Schedule**

No.	Topic	No. of Lectures
1	Module 1	
1.1	Introduction to Cryogenic Systems, Historical development, Low Temperature properties of Engineering Materials, Mechanical properties- Thermal properties- Electric and magnetic properties –Cryogenic fluids and their properties.	4
1.21.2	Applications of Cryogenics: Applications in space, Food Processing, super conductivity, Electrical Power, Biology, Medicine, Electronics and Cutting Tool Industry. Low temperature properties of engineering materials	3
2	Module 2	
2.1	Liquefaction systems ideal system, Joule Thomson expansion, Adiabatic expansion, Linde - Hampson Cycle, Claude & Cascaded System, Magnetic Cooling, Stirling Cycle Cryo Coolers.	4
1.22.2	Gas liquefaction systems: Introduction-Production of low temperatures-General Liquefaction systems- Liquefaction systems for Neon. Hydrogen and Helium – Critical components of Liquefaction systems	4
3	Module 3	
3.1	Cryogenic Refrigeration systems: Ideal Refrigeration systems- Refrigeration using liquids and gases as refrigerant- Refrigerators using solids as working media	4

1.23.2	Gas separation and purification: Thermodynamic ideal separation system, mixture characteristics, principle of gas separation, separation of air, hydrogen and helium, gas purification methods	3
4	Module 4	
4.1	Cryogenic fluid storage and transfer systems: Cryogenic Storage vessels and Transportation, Thermal insulation and their performance at cryogenic temperatures, Super Insulations, Vacuum insulation, Powder insulation, Cryogenic fluid transfer systems, Cryo pumping.	7
5	Module 5	
5.1	Cryogenic instrumentation, Pressure flow-level and temperature measurements, Types of heat exchangers used in cryogenic systems, Safety in cryogenic fluid handling, storage and use.	7

---

SEMESTER VIII

---

PROGRAM ELECTIVE V

---

COURSE CODE	COURSE NAME	CATEGORY	L	T	P	CREDITS
22MEE804.1	RELIABILITY ENGINEERING	PROGRAM ELECTIVE V	2	1	0	3

**Preamble:**

1. To induce in students an attitude towards reliability which will ensure that they lookout for steps to avoid failures to achieve success in all assignments they take up. That will help them become true engineers.

2. To generate in students an awareness of the importance of statistical concepts, and to make them realise that engineering is also largely statistics based.

Prerequisite: MAT 202 Probability, Statistics and Numerical Methods

Course Outcomes: After the completion of the course the student will be able to:

CO 1	Explain the basic concepts of reliability, various models of reliability and failure concepts.
CO 2	Analyse mathematical models of reliability and failure modes.
CO 3	Perform the design process of reliability.
CO 4	Explain the relation between reliability, availability and maintainability.
CO 5	Explain economic aspects of reliability and Perform reliability management effectively.

**Mapping of course outcomes with program outcomes**

	PO 1	PO 2	PO 3	PO 4	PO 5	PO 6	PO 7	PO 8	PO 9	PO 10	PO 11	PO 12
CO 1	2	2	2	2	1	1						
CO 2	2	3	2	2	2							
CO 3	3	2	1	2	1						2	
CO 4	3	1	3	1	1	1						
CO 5	2	2	1	2	3	1					2	

### Assessment Pattern

Bloom's Category	Continuous Assessment Tests		End Semester Examination
	1	2	
Remember	10	10	10
Understand	20	20	20
Apply	20	20	70
Analyse			
Evaluate			
Create			

### Mark distribution

Total Marks	CIE	ESE	ESE Duration
150	50	100	3 hours

### Continuous Internal Evaluation Pattern:

Attendance	: 10 marks
Continuous Assessment Test (2 numbers)	: 25 marks
Assignment/Quiz/Course project	: 15 marks

End Semester Examination Pattern: There will be two parts; Part A and Part B. Part A contain 10 questions with 2 questions from each module, having 3 marks for each question. Students should answer all questions. Part B contains 2 questions from each module of which student should answer any one. Each question can have maximum 2 sub-divisions and carry 14 marks.

### Course Level Assessment Questions

#### Course Outcome 1 (CO1):

1. Define the term reliability? Explain the reliability function.
2. Relate Reliability and Quality.
3. What is component failure and system failure?
4. Explain Weibull distribution and Normal distribution.

#### Course Outcome 2 (CO2)

1. Describe Weakest-link Technique.

2. Explain various mathematical models of reliability.
3. Explain Redundancy optimization.
4. Explain load sharing systems and standby system.

Course Outcome 3 (CO3):

1. How quality and reliability is related?
2. Explain System safety and Fault Tree Analysis.
3. What is Tie-set and Cut-set methods?
4. Explain the use of Boolean Algebra in reliability analysis.

Course Outcome 4 (CO4):

1. Describe repair time distribution in maintainability.
2. What is relationship between reliability and availability?
3. What is achieved availability and operational availability?
4. Explain Markovian models?

Course Outcome 5 (CO5):

1. What are the costs considered in reliability engineering?
2. Describe reliability achievement cost model?
3. Explain reliability utility cost model.
4. What are the functions of reliability management groups?



Model Question Paper

VIII SEMESTER BTECH DEGREE EXAMINATION  
MET418: RELIABILITY ENGINEERING

**Maximum:100 Marks**

**Duration:3 hours**

**PART A**

*Answer all questions, each question carries 3 marks*

1. Define the term reliability? Explain the reliability function.
2. Explain the term MTTF. Also derive it with respect to reliability and CDF.
3. State k-out-of-m system redundancy?
4. What is mixed redundancy?
5. Explain the static model for constant strength and load?
6. What is a tie and cut set?
7. Explain inherent availability?
8. What is MTBF?
9. Discuss the economic issues of reliability.
10. Draw and explain reliability-cost curves of a product.

**PART B**

Answer one full question from each module

**MODULE 1**

11. a) Draw and explain Bath tub Curve. (4)  
b) The time to wear for a cutting tool is distributed normally with a mean of 2.8 hour and standard deviation of 0.6 hour. Find
  - I. The probability that the tool will wear out in 1.5 hours
  - II. Find out the reliability for 1.5 hours
  - III. How often the cutting edge of the tool must be replaced in order to keep the failure less than 10 percentage? (10)
- 12.a) Find out the system reliability for a serial and parallel configuration with 2 components. (7)

b) Find out the reliability of the following system with 1,2,3,4,5 and 6 as 0.85,0.90, 0.95,0.90,0.80 and 0.85 respectively. Find out the tie sets and cut sets (7)

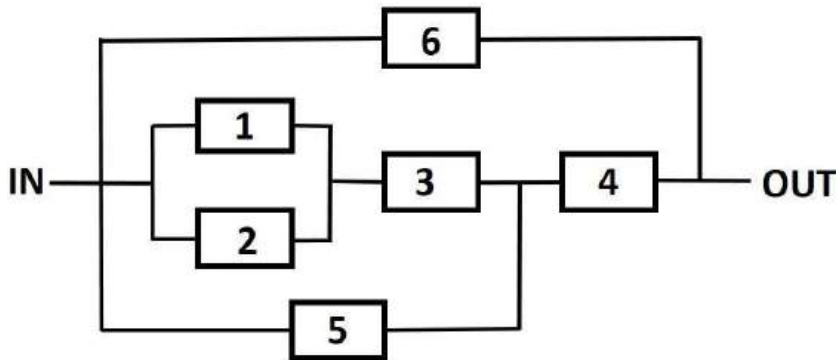

MODULE 2

13. a) Compare unit vs Component Redundancy with sketches (6)

b) Given a budget of Rs 700 and the following data on three components that must operate in series. Determine, using marginal analysis, the optimum number of redundant units. Compute the achieved reliability. (8)

Components	Reliability	Unit Cost (In rupees)
1	0.80	200
2	0.90	100
3	0.95	75

14. a) Find out the reliability using markov analysis for load sharing units? (6)

b) A manufacturing company operates two production lines when both lines are operating, the production rate on each line is 500 units per hour. At this production rate the failure rate of line 1 is 3 failures per 8-hr day (CFR) and the failure rate of line 2 is 2 failures per 8-hr day. When one line fails, the production rate of the second line must be increased in order to make production quotas. At the increased rate of 800 units per hour, the failure rate of line 1 is 6 per 8 hr day and the failure rate of line is 3 per 8-hr day. Find the reliability and the MTTF and the reliability of the production system over a 1 hr and over an 8 hr production run. (8)

### MODULE 3

15. a) With a block diagram explain the reliability design process. (5)

b) A system consists of three components in series having the following parameters. The reliability goal is 0.90 for the system. Do the reliability allocation. (9)

Components	Reliability	Unit Cost (In rupees)
1	0.85	25
2	0.80	20
3	0.90	40

16.a) Explain the steps in FMECA. (6)

b) In the context of fault tree analysis, explain the meaning of each of the following: an 'AND' gate, an 'OR' gate, a priority 'AND' gate, 'top' event, a 'basic' event, an 'undeveloped' event. In each of the case, sketch the conversional symbol used and give a practical example. (8)

### MODULE 4

17. a) Compute markov analysis of availability model for two component stand by system. (6)

b) A generator system consist of primary and a standby unit. The primary fails at a constant rate of 2 per month, and the stand by system fails only when online at a constant rate of 4 per month. Repair can begin only when both units have failed. Both units are repaired at the same time with an MTTR of 20 days. Derive the steady state equations for the state probabilities and solve for the system availability. (8)

18. a) What is inspection and repair availability model? Explain a case for it. (6)

b) Determine the upper bound for each of the following aircraft subsystems MTTRs if a system availability goal of 0.95 is desired. Assume the repair restores the subsystem to as good as new and each system has the same availability. (8)

Subsystem	Time Between failures	Parameters
Propulsion	Weibull	$\theta = 1000, \beta = 1.7$
Avionics	Exponential	$\lambda = 0.003$
Structures	Weibull	$\theta = 2000, \beta = 2.1$
Electrical	Weibull	$\theta = 870, \beta = 1.8$
Environmental	Exponential	$\lambda = 0.001$

## MODULE 5

19. Explain reliability achievement cost model (7)
20. Explain Reliability management by objectives (7)

## SYLLABUS

### Module – I

Reliability concepts: Definition of reliability, Reliability vs. Quality, Reliability function, MTTF, hazard rate function, bathtub curve, derivation of the reliability function, Failure and Failure modes, Causes of Failures and Unreliability. Reliability Models: constant failure rate model ,time dependent failure models. Weibull distribution, Normal distribution, log normal distribution. Serial configuration, parallel configuration, combined series parallel systems, K-out-of-m systems.

### Module – II

Redundancy Techniques in System design: Component vs Unit redundancy, Weakest-link Technique, Mixed redundancy, Standby redundancy, Redundancy optimization, Double failures and Redundancy. Markov analysis, load sharing systems, standby system, degraded systems, three state devices, covariate models.

### Module – III

Reliability design process, system effectiveness, economic analysis and life cycle cost, Reliability allocation, optimal allocations, ARINC, AGREE methods. System safety and Fault Tree Analysis, Tie-set and Cut-set methods, Use of Boolean Algebra in reliability analysis.

### Module – IV

Maintainability and Availability: Definitions and basic concepts, Relationship between reliability, availability and maintainability, Inherent availability, Achieved availability, Operational availability, Repairable systems, Markovian models. Reliability Allocation: for series system.

### Module – V

Economics of Reliability: Economic issues, Manufacturers cost, Customers cost, reliability achievement cost models, reliability utility cost models, depreciation cost models, availability cost model for parallel systems. Reliability management, Reliability management by objectives

Text books:

1. Balagurusamy E., *Reliability Engineering*, Tata McGraw Hill.
2. Srinath L. S., *Reliability Engineering*, East West Press.
3. Charles E. Ebeling, *Reliability and Maintainability Engineering*, Tata McGraw Hill.
4. Patrick D. T. O'Connor, *Practical Reliability Engineering*, John

Reference Books:

1. E.E. Lewis, *Introduction to Reliability Engineering*, JW.
2. NVR Naidu, et al, *Total Quality Management*, New Age International Publishers.
3. J.M. Juran and Frank M. Gryna, *Quality Planning and Analysis*, Tata McGraw Hill.

Course Contents and Lecture Schedule:

No	Topic	No. of Lectures
1.1	Definition of reliability, Reliability vs. Quality, Reliability function, MTTF, hazard rate function, bathtub curve, derivation of the reliability function	2
1.2	Failure and Failure modes, Causes of Failures and Unreliability	2
1.3	Reliability Models: constant failure rate model, time dependent failure models.	1
1.4	Weibull distribution, Normal distribution, lognormal distribution.	1
1.5	Serial configuration, parallel configuration, combined series parallel systems, K-out-of-m systems.	1
2.1	Redundancy Techniques in System design: Component vs Unit redundancy, Weakest-link Technique,	3
2.2	Mixed redundancy, Standby redundancy, Redundancy optimization Double failures and Redundancy.	3
2.3	Markov analysis, load sharing systems, standby system	1
3.1	Reliability design process, system effectiveness, economic analysis and life cycle cost	2
3.2	Reliability allocation, optimal allocations	1
3.3	ARINC, AGREE methods	1
3.4	System safety and Fault Tree Analysis, Tie-set and Cut-set methods	2
3.5	Use of Boolean Algebra in reliability analysis.	1
4.1	Maintainability and Availability: Definitions and basic concepts, Relationship between reliability, availability and maintainability	3

4.2	Inherent availability, Achieved availability, Operational availability	2
4.3	Operational availability, Repairable systems, Markovian models	2
4.4	Reliability Allocation: for series system.	1
5.1	Economics of Reliability: Economic issues, Manufacturers cost, Customers cost, reliability achievement cost models	3
5.2	reliability utility cost models, depreciation cost models, availability cost model for parallel systems	3
5.3	Reliability management, Reliability management by objectives	1

COURSE CODE	COURSE NAME	CATEGORY	L	T	P	CREDITS
22MEE804.2	PROJECT PLANNING AND MANAGEMENT	PROGRAM ELECTIVE V	2	1	0	3

Preamble: This course involves the application of principles studied in Project planning, Analysis, Selection Implementation of different project which has social cost, multiple projects, project review, financial analysis. This course also covers the financials of projects, improving and evaluating review the performance of the project. This course also helps to understand the risk analysis and capital budgeting and working capital management.

Prerequisite: Nil

Course Outcomes: After the completion of the course the student will be able to

CO 1	Overview about the Capital investment, Strategy, Generation & Screening of Project Idea, Demand analysis.
CO 2	Discuss the Technical Analysis, Product Mix, Plant Capacity, Cost of project and means finance. Cash flow, Projected Balance sheet, Trial balance, Profit and Loss account, Time value of money.
CO 3	Discus about the investment analysis, Cash flow of the project, Cost of capital, Project Risk, Multiple projects, Social Cost Benefit Analysis, Capital Budgeting.
CO 4	Rate return of projects, Project financing, Financing infrastructure projects, Financial Institutions, Working capital management. Term loan appraisal.
CO 5	Discuss the principles of Project Management, PERT, CPM, Project overview, Post audit, Critical path.

Mapping of course outcomes with program outcomes

	PO 1	PO 2	PO 3	PO 4	PO 5	PO 6	PO 7	PO 8	PO 9	PO 10	PO 11	PO 12
CO 1	3	2	2									
CO 2	2	2	3									
CO 3	3	2	2									
CO 4	3	2	2								2	
CO 5	2	2	3									

Assessment Pattern

Bloom's Category	Continuous Assessment Tests		End Semester Examination
	1	2	
Remember	10	10	10
Understand	20	20	20
Apply	20	20	70
Analyse			
Evaluate			
Create			

## Mark distribution

Total Marks	CIE	ESE	ESE Duration
150	50	100	3 hours

### Continuous Internal Evaluation Pattern:

Attendance	: 10 marks
Continuous Assessment Test (2 numbers)	: 25 marks
Assignment/Quiz/Course project	: 15 marks

End Semester Examination Pattern: There will be two parts; Part A and Part B. Part A contain 10 questions with 2 questions from each module, having 3 marks for each question. Students should answer all questions. Part B contains 2 questions from each module of which student should answer any one. Each question can have maximum 2 sub-divisions and carry 14 marks.

### Course Level Assessment Questions

#### Course Outcome 1 (CO1):

1. Types of capital investments and phases of capital budgeting. The detailed explanations of project analysis and key issues in major investment decisions.
2. Explain the grand strategy and diversification debates and SPACE.
3. What is positive NPV (net present value), explain tools for identifying investment opportunity.

#### Course Outcome 2 (CO2):

1. What is the industry specific source of secondary information and characteristics of market? Demand forecasting and trend projection.
2. What are the sources of uncertainties in demand? Describes the aspects covered in market planning.
3. Explain Plant capacity, Product mix, Location and Site? Describe the important charts and layout drawings.
4. Discuss the importance of Balance sheet and cash flow statement. Explain the means of finance.

#### Course Outcome 3(CO3):

1. What is an annuity? State the formula for the present value of an annuity?
2. What is NPV, IRR, Payback period? Explain the properties of the NPV rule?
3. Explain the principles of cash flow estimation? explain WACC and technics for risk analysis.



Course Outcome 4 (CO4):

1. Explain the portfolio theory and capital budgeting. Explain why the firms set a hurdle rate higher than the WACC.
2. How the economic life of a project determined? What is NPV and how is it calculate ?
3. Explain the public sector investment decision in India? Explain working capital management and project financing.
4. Explain capital structure? Explain key factors in determining the Debt- Equity ratio?

Course Outcome 5 (CO5):

1. Describe the PPP and its advantage and disadvantage.
2. Describe the tools of project planning and explain how the performance is analysed?
3. What are the pre-requisites for successful project implementation, explain?
4. What is essence of Project Management? Describe the notion of hierarchy of plans?
5. Explain network techniques and time estimations? Explain PERT and CPM.

Model Question Paper

APJ ABDUL KALAM TECHNOLOGICAL UNIVERSITY

VIII SEMESTER BTECH DEGREE EXAMINATION

MET428 : PROJECT PLANNING & MANAGEMENT

Maximum: 100 Marks

Duration:3 hours

PART A

Answer all questions, each question carries 3 marks

1. Explain Types of Capital Investments.
2. Explain the preliminary screening of project ideas.
3. What are the uncertainties in demand forecasting?
4. What are the factors influenced by the selection of Technology?
5. Explain Cash flow and cost of capital of a project?
6. Explain the procedure of Morse test.
7. Discuss about benefit cost ratio and IRR.
8. Explain sources, Measures and Perspectives on Risk?
9. Discuss the key factors in determining the Debt-Equity Ratio.
10. Define Network techniques for project management. Explain PERT and CPM.

(10×3=30 Marks)

## PART B

Answer one full question from each module

### MODULE 1

11. a) Explain the phases of Capital budgeting and Common weakness of Capital Budgeting? (8 marks)
- b) Derive the components of Marketing plan and key project inter-linkage? (6 marks)
12. a) Explain strategic planning and capital budgeting? Discuss the various strategies for growth strategy and contraction strategies. (8 marks)
- b) Discuss the source of positive NPV and qualities and traits required for a successful entrepreneur. (6 marks)

### MODULE 2

13. a) What is information required for preparing the project implementation schedule. Discuss the importance of considering alternative ways of transferring an idea in to a concrete project. (6 marks)
- b) Describe Cost project, Cost of Product and Means of finance ? (8 marks)
14. a) Explain cost of project, means of finance. Discuss contribution of a projected Balance sheet in a project? (6 marks)
- b) Explain Cash flow Statement, Balance sheet, Trail Balance and Profit and Loss account and Time value of Money? (8 marks)

### MODULE 3

15. a) What are the Investment Criteria? Describe NPV and IRR and properties of the NPV rule. (8 marks)
- b) Discuss the elements of Cash flow stream and basic principles of Cash flow estimation. (6 marks)
16. a) Describe the Sources, Measures and Perspectives on Risk. What are the techniques of Risk analysis and ways and means of mitigating Risk. (8 Marks)
- b) Explain Social cost and benefit differ from monetary costs and benefits. (4 marks)

### MODULE 4

17. a) Explain the Inventory management and Economic order quantity? (6 marks)
- b) Discuss the PPP and its relevance in India. Explain how financial institutions appraise a project.? (8 marks)
18. a) Explain the Working Capital Management? Discuss components of Credit policy and Impact of credit policy. (8 marks)
- b) Discuss the Cash flow process and its relevance. (6 marks)

MODULE 5

19. a) Explain PERT and CPM? Discuss the rules for the construction of Network Diagram? (6 marks)
- b) Why post audit be done? What is the advantage of conducting performance review? (4 marks)
- c) Explain the difference between Economic rate of return and Book return on Investment? (4 marks)
20. A project consisting of 12 activities and their time activities are shown

Activity.	Time (in weeks)		
	to	tm	tp
1-2	4	6	9
1-3	3	8	12
1-4	5	5	8
1-7	2	4	6
2-4	6	10	18
2-6	3	4	7
2-7	5	10	16
3-4	3	6	11
4-5	2	4	6
5-6	1	3	7
3-7	2	4	8
6-7	1	2	6

- a) Draw the Network diagram. (3 marks)
- b) Determine the Critical path. (3 marks)
- c) Calculate event slacks and activity floats. (3 marks)
- d) Find the standard Deviation of the critical path duration? (3 marks)
- e) Compute the probability of completing the project in 30 weeks. (2 marks)

## Syllabus

### Module 1

Capital Investment – importance and differences, Phases of Capital Budgeting, Decision making, Project analysis- Risks, Discounted cash flow (DCF), Financing, Earning per share (EPS), weakness in capital budgeting, Formulation of strategies, grand strategy, Diversification-risk reduction- value creation, portfolio strategy, business level strategies, screening of project idea, tools for identifying investment analysis, preliminary screening, positive net present value, demand forecasting, marketing plan, marketing survey. Demand analysis.

### Module 2

Manufacturing process/ technology, raw materials, product mix, plant capacity, location and site, plant and machinery, project chart and layout, project implementation, need for alternatives, project inter linkage, cost of project, means of finance, profitability projection, basic acceptance and principles of cash flow statement, projected balance sheet, trial balance, profit and loss account, time value of money.

### Module 3

Various investment criteria, net present value (NPV), benefit cost ratio (BCR), internal rate of return (IRR), pay back period, accounting rate of return, project cash flow – basic principle, biases in cash flow estimation, difference between company cost of capital and project cost of capital, project risk analysis, sources,-measures and perspective risk, break even analysis, scenario analysis, managing risk, social cost benefit analysis, UNIDO approach, features of capital budgeting, NPV-IRR comparison, multiple project and constrains.

### Module 4

Project financing, capital structure, key factors in determining the Debt-Equity ratio, sources of finances, equity capital, preference capital, term loan, working capital, project financing structure, financial closure, financial institutions, information and documents for term loan appraisal, project appraisal, credit risk rating, private public partnership (PPP) managing risk in private infrastructure project, working capital management, working capital policy, estimation of working capital, inventory management, purchase, optimum level of inventory, economic order quantity, just in time (JIT). Cash Management, Cash flow process. Term loan appraisal, PPP, Inventory Management, Receivable Management, Cash Management.

### Module 5

Project management, principle- forms of project organisation, project planning, project control, authority, orientation , motivation, group function, pre-requisite for successful project implementation, accounts receivable, impact of credit policy, components of credit policy, cash management, motives for holding cash, cash flow process and its relevance, principles of cash management, collection and disbursement management, cash forecasting, network techniques in project management, development of project network, rules for network construction, time estimation, determination of critical path, schedule when resources are limited, Network Technologies, PERT model, CPM model, network cost system, project review, post audit, abandonment analysis, overcome resistance, managing divestments, Project review.

### Text Books

1. Weist, J.D, and F.K. Levy, A management Guide to PERT/CPM, Prectice-Hall of India, New Delhi, 1974.
2. Pouliquen.L.Y, Risk analysis in Project aAprisal, Johns Hopkins Press, Baltimore, California. 1970.
3. Rajiv Srivastava and Anil Misra, Financial Management, Oxford University Press, New Delhi.
4. Dr.Prasanna Chandra. Project Planning, Implementation and Review. Tata McGraw Hill , NewDelhi.

### Reference Books

1. Amran M and N.Kulatilalka, Managing strategic investment in Uncertian world. HARward Business school press, Boston 2000.
2. Reghuram G Infrastructure development and financing, Macmilloan India, Delhi, 1999
3. UNIDO, Guidline for project evaluation, United nations, 1972
4. Weingartner, M.H., Mathematical programming and Analysis of capital budjeting problemes, Prentice-Hall, EnglewoodmCliffs, N.J, 1963.

### Course Contents and Lecture Schedule

No	Topic	No. of Lectures
1		
1.1	Capital Investment – importance and differences, Phases of Capital Budgeting, Decision making, Project analysis- Risks, Discounted cash flow (DCF), Financing, Earning per share (EPS), weakness in capital budgeting, Formulation of strategies, grand strategy,	3
1.2	Diversification-risk reduction- value creation, portfolio strategy, business level strategies, screening of project idea, tools for identifying investment analysis,	2
1.3	preliminary screening, positive net present value, demand forecasting, marketing plan, marketing survey, Demand analysis.	2
2		
2.1	Manufacturing process/ technology, raw materials, product mix, plant capacity, location and site, plant and machinery, project chart and layout, project implementation, need for alternatives, project inter linkage,	2
2.2	Cost of project, means of finance, profitability projection, basic acceptance and principle of cash flow statement, time value of money.	2

2.3	Projected balance sheet, trial balance, profit and loss account,	3
3		
3.1	Various investment criteria, net present value (NPV), benefit cost ratio (BCR), internal rate of return (IRR), payback period, accounting rate of return, project cash flow – basic principle, biases in cash flow estimation	3
3.2	Difference between cost of capital and project cost of capital, project risk analysis, sources, -measures and perspective risk, break even analysis, scenario analysis, managing risk.	2
3.3	social cost benefit analysis, UNIDO approach, features of capital budgeting, NPV-IRR comparison, multiple projects and constrains	2
4		
4.1	Project financing, capital structure, key factors in determining the Debt-Equity ration, sources of finances, equity capital, preference capital, term loan, working capital, project financing structure, financial closure, financial institutions,	3
4.2	information and documents for term loan appraisal, project appraisal, credit risk rating, private public partnership (PPP)managing risk in private infrastructure project, working capital management, working capital policy, estimation of working capital, Term loan appraisal, PPP.	2
4.3	Inventory management, purchase, optimum level of inventory, economic order quantity, just in time (JIT). Cash Management, cash flow process, Cash management.	2
5		
5.1	Project management, principle- forms of project organisation, project planning, project control, authority, orientation, motivation, group function, pre-requisite for successful project implementation	2
5.2	Accounts receivable, impact of credit policy, components of credit policy, cash management, motives for holding cash, cash flow process and its relevance, principles of cash management, collection and disbursement management, cash forecasting,	2
5.3	Network techniques in project management, development of project network, rules for network construction, time estimation, determination of critical path, schedule when resources are limited, PERT model, CPM model, network cost system, project review, post audit, abandonment analysis, overcome resistance, managing divestments, decision making, Project review.	3



### Assessment Pattern

Bloom's Category	Continuous Assessment Tests		End Semester Examination
	1	2	
Remember			
Understand	30	30	30
Apply	20	20	70
Analyse			
Evaluate			
Create			

### Mark distribution

Total Marks	CIE	ESE	ESE Duration
150	50	100	3 hours

### Continuous Internal Evaluation Pattern:

Attendance	: 10 marks
Continuous Assessment Test (2 numbers)	: 25 marks
Assignment/Quiz/Course project	: 15 marks

End Semester Examination Pattern: There will be two parts; Part A and Part B. Part A contain 10 questions with 2 questions from each module, having 3 marks for each question. Students should answer all questions. Part B contains 2 questions from each module of which student should answer any one. Each question can have maximum 2 sub-divisions and carry 14 marks.

### Course Level Assessment Questions

#### Course Outcome 1 (CO1):

1. Describe the historical perspective of fracture and failure studies.
2. Explain the different modes of fracture failure.
3. Explain damage tolerance approach in design.



#### Course Outcome 2 (CO2)

1. Explain the concept of crack propagation based on energy release rate and surface energy.
2. Explain change in compliance approach and change in strain energy approach in crack propagation study.
3. Explain the difference between stable and unstable crack growth using R curve.

#### Course Outcome 3(CO3):

1. Explain the advantages of Stress Intensity factor over Energy release rate in fracture studies.
2. Solve simple problems using stress Intensity factor equations for mode 1, mode 2 and mode 3 type fracture failure.
3. Derive the stress Intensity factor equations for mode 1, mode 2 and mode 3 type fracture failure.

#### Course Outcome 4 (CO4):

1. Explain the plastic zone shape for plane stress and plane strain using a neat figure
2. Explain Irwin's correction for determining plastic zone size.
3. Explain Dugdale approach to find the size of the crack tip plastic zone.

#### Course Outcome 5 (CO5):

1. Explain the conditions for rapid crack propagation and crack arrest
2. Explain Paris Law and crack closure.
3. Explain the different causes of corrosion

Model Question Paper

Maximum: 100 Marks

Duration: 3 hours

MET438 FRACTURE MECHANICS

Answer all questions. Each question carries 3 marks

(10 X 3 = 30 Marks)

1. List any six causes of mechanical failure.
2. Differentiate between brittle and ductile fracture.
3. Define Griffith's theory.
4. Explain Surface energy of a solid.
5. Explain Stress Intensity Factor.
6. What is a singularity? What kind of singularity describes a stress field near the vicinity of a crack tip in LEFM?
7. In comparison to a plane strain case, a plane stress loading gives much larger plastic zone for the same SIF? Why?
8. Explain the term 'effective crack length'.
9. Explain the effect of an overload pulse inside a constant amplitude fatigue load on crack propagation.
10. Why does the environment-assisted cracking occur mostly through inter-granular growth?

PART B

Answer one question from each module

MODULE 1

11. Explain with neat sketch the different modes of fracture failure.

OR

12. Discuss the historic overview of Fracture Mechanics.

MODULE 2

13. Derive the equation to find the energy release rate,  $G$  of a double cantilever beam (DCB), subjected to (i) constant load  $P$  and (ii) constant displacement.

OR

14. Explain the conditions for stable and unstable crack growth in a ductile material using R curve

MODULE 3

15. For a centre crack in an infinite plate loaded in Mode II, determine stress components and displacement components (plane stress) near the vicinity of a crack tip in terms of  $K_{II}$ .

OR

16. In a large plate, a crack of length  $2a$  is inclined with an angle  $\alpha$  with  $x_1$ -axis as shown in figure. The plate is loaded in  $x_2$  direction with  $\sigma_{22} = \sigma$ . (i) Find the stress intensity factors. (ii) For  $\sigma = 80$  MPa,  $2a = 20$  mm and  $\alpha = 30^\circ$ , determine  $K_I$  and  $K_{II}$ .

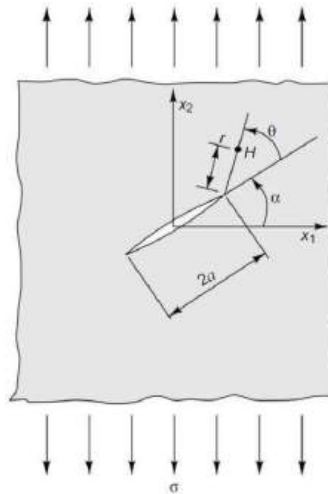

MODULE 4

17. Explain with neat sketch, the plastic zone shape for plane stress condition.

OR

18. A large plate of 5 mm thickness, made of medium carbon steel ( $\sigma_{ys} = 350$  MPa) with a through-the-thickness centre-crack of  $2a = 40$  mm length, is subjected to a stress of 150 MPa. For Mode I loading, determine the effective crack length using Irwin's correction.

MODULE 5

19. What do you mean by crack closure? What are the factors affecting crack closure? Explain its effects on crack propagation.

OR

20. Explain the major factors influencing environment-assisted fracture.

## Syllabus

### Module 1

Introduction to fracture mechanics: - Review on conventional design methodologies, Brittle and ductile fracture, Modes of fracture failure, Damage tolerance, Spectacular failures, Lessons from spectacular failures, fracture mechanics approach to design, damage tolerance approach to design (review).

### Module 2

Griffith's Dilemma – surface energy- Griffith analysis – Energy Release Rate – Double cantilever beam (DCB) with constant load, DCB with fixed grip, Energy release rate of DCB specimen.

Anelastic deformation at crack-tip, Crack resistance, stable and unstable crack growth, R-curve, Critical energy release rate (concepts only).

### Module 3

Linear Elastic Fracture Mechanics (LEFM): - stress and displacement fields in isotropic elastic materials - Stress intensity factor - Field equations - Airy's Stress Function - Biharmonic Equation, Westergaard's Approach (concepts only, no derivations, final result).

### Module 4

Anelastic Plastic Zone Shape and Size: - plastic zone shape for plane stress - plastic zone shape for plane strain. Effective Crack Length: - approximate approach - Irwin's correction – Dugdale approach.

### Module 5

J - Integral: Path independence of J - integral (concepts only), stress strain relation, Engineer approach to J – integral, Ramberg - Osgood relation (simple problem only). Fatigue Crack Propagation: - Paris Law – crack closure. Environmentally Assisted Cracking: - types of corrosion – cracking mechanism. Corrosion Fatigue (concepts only).

### Text Books

1. Prashant Kumar, Elements of Fracture Mechanics, Tata McGraw Hill, New Delhi, India, 2009

### Reference Books

1. T.L. Anderson, Fracture Mechanics – Fundamentals and Applications, 3rd Edition, Taylor and Francis Group, 2005.

2. K. Ramesh, e-Book on Engineering Fracture Mechanics, IIT Madras, 2007. URL: [http://apm.iitm.ac.in/smlab/kramesh/book\\_4.htm](http://apm.iitm.ac.in/smlab/kramesh/book_4.htm)

3. K. R.Y. Simha, Fracture Mechanics for Modern Engineering Design, Universities Press (India) Limited, 2001
4. Kare Hellan, "Introduction of Fracture Mechanics", McGraw-Hill Book Company, 1985.
5. David Broek, "Elementary Engineering Fracture Mechanics", Fifth off and Noerdhoff International Publisher, 1978.
6. Kachanov.L.M., "Foundations of Theory of Plasticity", North-Holland Publishing Co., 1971.

#### Course Contents and Lecture Schedule

No	Topic	No. of Lectures
1	Module-1	6 Hr
1.1	Introduction to fracture mechanics: - Review on conventional design methodologies	1
1.2	Brittle and ductile fracture, Modes of fracture failure	1
1.3	Damage tolerance, Spectacular failures	1
1.4	,Lessons from spectacular failures,	1
1.5	fracture mechanics approach to design	1
1.6	Damage tolerance approach to design (review).	1
2	Module-2	7 Hr
2.1	Griffith's Dilemma – surface energy-	1
2.2	Griffith analysis – Energy Release Rate –	1
2.3	Double cantilever beam (DCB) with constant load, DCB with fixed grip,	1
2.4	Energy release rate of DCB specimen	1
2.5	Anelastic deformation at crack-tip, R-curve,	1
2.6	Crack resistance, stable and unstable crack growth,	1
2.7	R-curve, Critical energy release rate (concepts only).	1
3	Module-3	8 Hr
3.1	Linear Elastic Fracture Mechanics (LEFM):	2
3.2	- stress and displacement fields in isotropic elastic materials - - ,	1
3.3	Stress intensity factor - Field equations - Airy's Stress Function	2
	Biharmonic Equation	1
3.4	Westergaard's Approach (concepts only, no derivations, final result)	2
4	Module-4	8 Hr
4.1	Anelastic Plastic Zone Shape and Size:	2
4.2	plastic zone shape for plane stress	1
4.3	Effective Crack Length: - approximate approach	1

4.4	plastic zone shape for plane strain.	2
4.5	Irwin's correction	1
4.6	Dugdale approach	1
5	Module-5	8 Hr
5.1	J - Integral: Path independence of J - integral (concepts only)	1
5.2	Stress strain relation	1
5.3	Engineer approach to J – integral	1
5.4	Ramberg - Osgood relation (simple problem only)	1
5.5	Paris Law – crack closure. Environmentally Assisted Cracking	2
5.6	Types of corrosion – cracking mechanism. Corrosion Fatigue (concepts onl	2



### Assessment Pattern

Bloom's Category	Continuous Assessment			End Semester Examination
	Assignment (%)	Test 1 (%)	Test 2 (%)	
Remember	25	20	20	10
Understand	25	40	40	20
Apply	25	40	40	70
Analyse	25			
Evaluate				
Create				

### Mark distribution

Total Marks	CIE	ESE	ESE Duration
150	50	100	3 hours

### Continuous Internal Evaluation Pattern:

Attendance	: 10 marks
Continuous Assessment Test (2 numbers)	: 25 marks
Assignment/Quiz/Course project	: 15 marks

End Semester Examination Pattern: There will be two parts; Part A and Part B. Part A contain 10 questions with 2 questions from each module, having 3 marks for each question. Students should answer all questions. Part B contains 2 questions from each module of which student should answer any one. Each question can have maximum 2 sub-divisions and carry 14 marks.

### Course Level Assessment Questions

#### Course Outcome 1 (CO1):

1. Represent Brayton cycle in PV and TS coordinates.
2. Define closed cycle and semi closed cycle gas turbines

#### Course Outcome 2 (CO2)

1. Discuss laws pertaining to Gas Turbines
2. Discuss laws pertaining to Jet Propulsion



Course Outcome 3 (CO3):

1. Discuss problems related to Gas Turbines
2. Discuss problems related to Jet Propulsion

Course Outcome 4 (CO4):

1. Discuss about the solutions related to Gas Turbine problems
2. Discuss about the solutions related to Jet Propulsion problems

Course Outcome 5 (CO5):

1. Discuss about the applications in the field

Course Outcome 6 (CO6):

1. Discuss about different techniques in rocket propulsion

Model Question Paper

APJ ABDUL KALAM TECHNOLOGICAL UNIVERSITY

GAS TURBINES AND JET PROPULSION -MET448

Maximum: 100 Marks

Duration: 3 hours

PART A

Answer all questions. Each question carries 3 marks

(10 X 3 = 30 Marks)

1. What are the applications of gas turbines?
2. List the advantages of closed cycle gas turbine system over open cycle system.
3. What are the different methods used to improve the efficiency of gas turbine
4. Explain the significance of intercooler. What is meant by perfect intercooling?
5. Why are propeller engines not commonly used nowadays in aircrafts?
6. State the difference between air breathing and non-air breathing propulsion
7. Define thrust power and propulsive power.
8. What is propellant? How are propellants classified?

9. Explain about free radical propulsion.
10. What is meant by thrust and its limiting factors?

## PART B

Answer one question from each module

### MODULE 1

11. An air nozzle is to be designed for an exit Mach number of 2. conditions of the air available in the reservoir are 700 kPa, 533 K. Estimate i) pressure ii) temperature iii) velocity of flow iv) area, at throat and exit of the nozzle. Mass flow rate through the nozzle is 10000 kg/hr.

14 marks

12. Derive the conservation of mass equation for compressible flow through control volume approach.

14 marks

### MODULE II

13. Explain constant pressure and constant volume gas turbines with diagrams

14 marks

14. Explain intercooling, reheating and their combinations

14 marks

### MODULE III

15. Explain the operation of single stage reciprocating compressor

14 marks

16. Explain centrifugal compressors and axial flow compressors

14 marks

### MODULE IV

17. Explain factors affecting combustion chamber design

14 marks

18. Explain gas turbine combustion chamber performance

14 marks

### MODULE V

19. Explain air breathing propulsion system

14 marks

20. Explain rocket propulsion system

14 marks

Note: Problems also can be asked from module 2 and 3. Each question can have maximum two sub divisions

## Syllabus

Module 1- Compressible Flow: Wave propagation and sound velocity; Mach number and compressible flow regimes; basic equations for one-dimensional compressible flow, isentropic flow relations; area-velocity relation; normal shock waves, relation between upstream and downstream flow parameters.

Module 2- Gas Turbine Systems and Cycles: System of operation of gas turbines-constant volume and constant pressure gas turbines; thermodynamics of Brayton cycle; regeneration-inter-cooling, reheating and their combinations; closed cycle and semi-closed cycle gas turbines; Compare Gas turbines, I.C engines and steam turbines.

Module 3- Compressors: Classification-positive displacement and dynamic compressors, Operation of single stage reciprocating compressors; isothermal efficiency; volumetric efficiency; multi-stage compression. Centrifugal compressors; principle of operation; work done and pressure rise; diffuser; compressibility effects; non dimensional quantities for plotting compressor characteristics; compressor characteristics. Axial flow compressors; basic operation; elementary theory; factors effecting stage pressure ratio; degree of reaction; calculation of stage performance; Axial flow characteristics.

Module 4- Combustion Systems: Types, operational requirements; combustion process; factors affecting combustor design; combustion chamber performance; Gas turbine emissions.

Module 5- Air-breathing Propulsion Systems: Principle of jet propulsion; analysis and performance characteristics of turbojet, turboprop, ramjet and pulsejet; thrust power and propulsion efficiency. Rocket Propulsion: Operating principle; solid and liquid propellants, performance analysis-calculations for specific impulse and propulsive efficiency.

### Text Books

1. Gas Turbine Theory – Saravanamuttoo, Cohen and Rogers, Pearson Education Asia
2. Gas Turbines – V. Ganesan, Tata McGraw Hill

### Reference books

1. Elements of Gas Turbine Propulsion- James Mattingly, Tata McGraw Hill
2. Gas Turbine Engine Technology – Irwin E Treager, McGraw Hill Education, 2013

Course Contents and Lecture Schedule

MODULE	TOPICS	HOURS ALLOTTED
1	Compressible Flow: Wave propagation and sound velocity; Mach number and compressible flow regimes; basic equations for one-dimensional compressible flow, isentropic flow relations; area-velocity relation; normal shock waves, relation between upstream and downstream flow parameters.	4-1-0
2	Gas Turbine Systems and Cycles: System of operation of gas turbines-constant volume and constant pressure gas turbines; thermodynamics of Brayton cycle; regeneration- inter-cooling, reheating and their combinations; closed cycle and semi-closed cycle gas turbines; gas turbine v/s I.C engines and steam turbines.	4-2-0
3	Compressors: Classification-positive displacement and dynamic compressors, Operation of single stage reciprocating compressors; isothermal efficiency; volumetric efficiency; multi-stage compression. Centrifugal compressors; principle of operation; work done and pressure rise; diffuser; compressibility effects; non dimensional quantities for plotting compressor characteristics; compressor characteristics. Axial flow compressors; basic operation; elementary theory; factors effecting stage pressure ratio; degree of reaction; calculation of stage performance; Axial flow characteristics.	6-2-0
4	Combustion Systems: Types, operational requirements; combustion process; factors affecting combustor design; combustion chamber performance; Gas turbine emissions.	4-1-0
5	Air-breathing Propulsion Systems: Principle of jet propulsion; analysis and performance characteristics of turbojet, turboprop, ramjet and pulsejet; thrust power and propulsion efficiency	4-1-0
	Rocket Propulsion: Operating principle; solid and liquid propellants, performance analysis-calculations for specific impulse and propulsive efficiency.	5-1-0

COURSE CODE	COURSE NAME	CATEGORY	L	T	P	CREDITS
22MEE804.5	ADVANCED ENERGY ENGINEERING	PROGRAM ELECTIVE V	2	1	0	3

Preamble: This course provides basic ideas about various energy source and its environmental impacts.

Prerequisite : Nil

Course Outcomes :After completion of the course the student will be able to

CO1	Explain the concept of various types of power generation
CO2	Explain solar and wind power generation and its economics
CO3	Explain biomass energy sources and its economics
CO4	Explain various renewable energy sources
CO5	Explain environmental impacts of various energy generation

Mapping of course outcomes with program outcomes

	PO 1	PO 2	PO 3	PO 4	PO 5	PO 6	PO 7	PO 8	PO 9	PO 10	PO 11	PO 12
CO 1	3	1										
CO 2	3	1										
CO 3	3	1										
CO 4	3	1										
CO 5	3	1				1	1					
CO 6	3	1										

Bloom's Category	Continuous Assessment Tests		End Semester Examination
	1	2	
Remember	10	10	10
Understand	20	20	20
Apply	20	20	70
Analyse			
Evaluate			
Create			

### Mark distribution

Total Marks	CIE	ESE	ESE Duration
150	50	100	3 hours

### Continuous Internal Evaluation Pattern:

Attendance : 10 marks

Continuous Assessment Test (2 numbers) : 25 marks

Assignment/Quiz/Course project : 15 marks

End Semester Examination Pattern: There will be two parts; Part A and Part B. Part A contain 10 questions with 2 questions from each module, having 3 marks for each question. Students should answer all questions. Part B contains 2 questions from each module of which student should answer any one. Each question can have maximum 2 sub-divisions and carry 14 marks.

### Course Level Assessment Questions:

#### Course Outcome 1 (CO1):

1. Discuss the renewable energy potential of India.
2. Explain briefly global energy resources.
3. Explain the working and components of a thermal power plant with the help of a neat layout.

#### Course Outcome 2 (CO2):

1. Explain briefly about the different types of solar collectors with neat sketches.
2. Explain the working of solar photovoltaic cells.
3. List the different methods used to estimate wind speed at a location.
4. Discuss site selection for wind power plants?

#### Course Outcome 3 (CO3):

1. Which are the main sources of Biomass?
2. With a neat sketch explain the working of a fixed dome type biogas plant.
3. Explain the biochemical and thermo chemical methods of biomass conversion.

#### Course Outcome 4 (CO4):

1. Explain the working principle of MHD power generation with a sketch.
2. Explain the components and working principle of any one hybrid power plant with sketches.
3. With the help of a neat diagram explain the working principle and applications of fuel cells.

#### Course Outcome 5 (CO5):

1. Explain any three methods for controlling air pollution by thermal power plants.
2. What is cause for the loss of biodiversity and how is biodiversity protected?
3. Describe the actions to be taken for sustainability of energy.

Model Question Paper

VI SEMESTER B.TECH DEGREE EXAMINATION  
MET458: ADVANCED ENERGY ENGINEERING

Maximum: 100 Marks

Duration: 3 hours

PART A

Answer all questions, each question carries 3 marks

1. Elaborate on the current global energy supply scenario.
2. What are the renewable energy resources? Discuss their importance in India's power requirement context.
3. Explain the basic principle of wind energy conversion.
4. Distinguish between active and passive solar energy systems.
5. Explain the category of biomass resources.
6. "Energy released from biomass comes from Sun". elaborate on this point
7. Mention the impact of tidal energy power plants in the environment
8. Name the different processes used for Hydrogen production.
9. What is biodiversity?
10. List any four sources of land degradation ( 10 X 3 = 30 marks)

PART B

Answer one full question from each module

Module 1

11. (i) Sketch the layout of a diesel power plant. Explain the layout. (10 marks)
- (ii) How do Industry Nation and Globe would benefit from energy efficiency programs. (4 marks)

OR

12. Give the schematic layout of a thermal power plant and explain its working with the help of Rankine cycle (14 marks)

Module 2

- 13 Explain briefly about the different types of solar collectors with neat sketches. (14 marks)

OR

14. (i) Elaborate on the construction and working of the different types of horizontal axis wind turbine. (10 marks)
- (ii). What is the advantages of wind energy conversion systems? (4 marks)

Module 3

15. (i) Explain the biochemical and thermo chemical methods of biomass conversion (10 marks)  
(ii) What is the difference between biomass and biogas? (4 marks)

OR

16. (i).With a neat sketch explain the working of a fixed dome type biogas plant. (10 marks)  
(ii). Write a short note on gasification of biomass? (4 marks)

Module 4

17. With the help of a schematic diagram explain the closed cycle MHD and open cycle MHD (14 marks)

OR

18. With the help of a neat diagram explain the working principle and applications of fuel cells. (14 marks)

Module 5

- 19.(i).Briefly explain any four air pollutants and their effects (8 marks)  
(ii) Explain the causes and effects of eutrophication (6 marks)

OR

- 20 (i).Define Global warming. What are the reasons for Global warming? (10 marks)  
(ii). List out the environmental impact of utilizing hydroelectric power (4 marks)



## Syllabus

### Module 1

Introduction to the course, Global and Indian energy resources. Energy demand and supply. components, layout and working principles of steam, hydro, nuclear, gas turbine and diesel power plants .

### Module 2

Solar Energy- passive and active solar thermal energy, solar collectors, solar thermal electric systems, solar photovoltaic systems, economics of solar power

Wind Energy- Principle of wind energy conversion system, wind turbines, aerodynamics of wind turbines, wind power economics, Introduction to solar-wind hybrid energy

### Module 3

Biomass Energy – Biomass as a fuel, thermo-chemical, bio-chemical and agro-chemical conversion of biomass- pyrolysis, gasification, combustion and fermentation, transesterification, economics of biomass power generation, future prospects

### Module 4

Other Renewable Energy sources – Brief account of Geothermal, Tidal, Wave, MHD power generation. Fuel cells – general description, types, applications. Hydrogen energy conversion systems, hybrid systems- Economics and technical feasibility

### Module 5

Environmental impact of energy conversion – ozone layer depletion, global warming, greenhouse effect, loss of biodiversity, eutrophication, acid rain, air and water pollution, land degradation, thermal pollution, Sustainable energy, promising technologies, development pathways

### Text Books:

1. P K Nag, Power Plant Engineering, TMH, 2002
2. Jefferson W Tester, Sustainable Energy Choosing among options, PHI, 2006
3. Tiwari G N, Ghosal M K, Fundamentals of renewable energy sources, Alpha Science International Ltd., 2007

### Reference Books:

1. David Merick, Richard Marshall, Energy, Present and Future Options, Vol.I & II, John Wiley & Sons, 2001
2. Godfrey Boyle, Renewable Energy : Power for a Sustainable Future, Oxford University Press, 2012
3. Herbert E. Merritt, Hydraulic control systems, John Wiley & Sons, 2012
4. Roland Wengenmayr, Thomas Buhrke, 'Renewable Energy: Sustainable energy concepts for the future, Wiley – VCH, 2012
5. Twidell J W and Weir A D, Renewable Energy Resources, UK, E&F.N. Spon Ltd., 2006

## Course Contents and Lecture Schedule

No.	Topic	No. of Lectures
I	Introduction to the course, Global and Indian energy resources. Energy demand and supply. Components, layout and working principles of steam, hydro, nuclear, gas turbine and diesel power plants	7
II	Solar Energy- passive and active solar thermal energy, solar collectors, solar thermal electric systems, solar photovoltaic systems, economics of solar power	6
	Wind Energy-Principle of wind energy conversion system, wind turbines, aerodynamics of wind turbines, wind power economics, Introduction to solar-wind hybrid energy	5
III	Biomass Energy – Biomass as a fuel, thermo-chemical, bio-chemical and agro-chemical conversion of biomass- pyrolysis, gasification, combustion and fermentation, transesterification, economics of biomass power generation, future prospects	6
IV	Other Renewable Energy sources – Brief account of Geothermal, Tidal , Wave, MHD power generation. Fuel cells – general description, types, applications. Hydrogen energy conversion systems, hybrid systems- Economics and technical feasibility	6
V	Environmental impact of energy conversion – ozone layer depletion, global warming, greenhouse effect, loss of biodiversity, eutrophication, acid rain, air and water pollution, land degradation, thermal pollution, Sustainable energy, promising technologies, development pathways`	6

COURSE CODE	COURSE NAME	CATEGORY	L	T	P	CREDITS
22MEE804.6	ADDITIVE MANUFACTURING	PROGRAM ELECTIVE V	2	1	0	3

Preamble: This course addresses additive manufacturing principles, variety and its concept, scope of additive manufacturing and areas of application

Prerequisite: NIL

Course Outcomes: After the completion of the course the student will be able to

CO Nos	Course Outcomes	Level of learning domain
CO 1	Discuss various additive manufacturing processes	2
CO 2	Explain slicing operations in additive manufacturing	2
CO 3	Use liquid and solid based additive manufacturing system	3
CO 4	Select powder based and use of pre requirement of AM	2
CO 5	Apply rapid prototyping techniques for obtaining solutions	3

Mapping of course outcomes with program outcomes

	PO 1	PO 2	PO 3	PO 4	PO 5	PO 6	PO 7	PO 8	PO 9	PO 10	PO 11	PO 12
CO 1	2				2		2					1
CO 2	3	2			2		2					1
CO 3	2				2		2					1
CO 4	2				2		2					1
CO 5	3	2			2		2					1

Assessment Pattern

Bloom's Category	Continuous Assessment Tests		End Semester Examination
	1	2	
Remember	25	25	25
Understand	35	35	35
Apply	40	40	40
Analyse			
Evaluate			
Create			

### Mark distribution

Total Marks	CIE	ESE	ESE Duration
150	50	100	3 hours

### Continuous Internal Evaluation Pattern:

Attendance	: 10 marks
Continuous Assessment Test (2 numbers)	: 25 marks
Assignment/Quiz/Course project	: 15 marks

End Semester Examination Pattern: There will be two parts; Part A and Part B. Part A contain 10 questions with 2 questions from each module, having 3 marks for each question. Students should answer all questions. Part B contains 2 questions from each module of which student should answer any one. Each question can have maximum 2 sub-divisions and carry 14 marks.

### Course Level Assessment Questions

#### Course Outcome 1 (CO1):

1. What is additive manufacturing?
2. What is STL file?
3. What is AM process chain?

#### Course Outcome 2 (CO2)

1. What is Model Slicing?
2. What are the softwares used for Tool path generation
3. What are the softwares currently used for AM?
4. What are the limitations of Tool path generation?

#### Course Outcome 3(CO3):

1. Brief the post processing types of LENS.
2. What are process variables in FDM?
3. What are the applications of EDM?

#### Course Outcome 4 (CO4):

1. What is STL file?
2. How does 3d Printing Work?
3. What are the merits of SLM?

Course Outcome 5 (CO5):

1. What are the benefits of rapid tooling?
2. What are the applications of rapid tooling?
3. What is Rapid Tooling?

Model Question Paper

MET 468 ADDITIVE MANUFACTURING

Max. Marks : 100  
Hours

Duration : 3

Part – A

Answer all questions, each question carries 3 marks

1. Write a note on product development by AM?
2. Classify and Explain of additive manufacturing processes?
3. Brief about Support structure design?
4. What are the advantages of Part orientation?
5. Brief the LOM process.
6. What are the materials used in SLS
7. What are the strength and weakness of 3DP?
8. What are the merits of SLM?
9. What are the fundamentals of Rapid Prototyping?
10. List the types of industries that RP can be used in industrial applications?

PART -B

Answer one full question from each module.

MODULE – 1

- 11 a) Write a note on the benefits and applications of AM. (6 marks)  
b) Write a note on the impact of AM on product development. (8 marks)

OR

12. a) Write a note on the need and development of AM systems. (8 marks)  
b) Classify and explain the AM process. (6 marks)

MODULE – 2

13. a) Explain about data formats and data interfacing? (6 marks)  
b) What is part orientation? Explain with illustrations? (8 marks)

OR

14. a) Explain the need of support generation with flow charts? (8 marks)  
b) What are the steps involved in model slicing? (6 marks)

MODULE – 3

15. a) Brief about strength, Weakness and applications of SLA? (8 marks)  
b) Explain the working principle and process variables of FDM. (6 marks)

OR

- 16 a) Brief about strength, Weakness and applications of SLS? (8 marks)  
b) Explain the working principle and process variables of LOM. (6 marks)

MODULE – 4

- 17.a) Explain the working principle and process variables of 3DP (6 marks)  
b) Compare solid, liquid and powder based system of 3DP. (8 marks)

OR

- 18 a) what is STL Format? Explain any two translators used in place of STL? (8 marks)  
b) Explain the working principle and process variables of 3DP? (6 marks)

MODULE – 5

- 19 a) what are the benefits of using color in production of medical models? (6 marks)  
b) What AM materials are already approved for medical applications and for what types of application are they suitable? (8 marks)

OR

- 20 a) Discuss the steps followed in rapid prototyping process. (6 marks)  
b) What is rapid tooling and explain the applications of RPT in manufacturing and tooling. (8 marks)

## SYLLABUS

### Module 1

Introduction to Additive manufacturing: Importance of Additive Manufacturing- Basic principle of additive manufacturing- Procedure of product development in additive manufacturing. Classification of additive manufacturing processes, Materials used in additive manufacturing- Benefits & Challenges in Additive Manufacturing.

### Module 2

Basic Concept — Digitization techniques — Model Reconstruction — Data Processing for Additive Manufacturing Technology: CAD model preparation — Part Orientation and support generation — Model Slicing — Tool path Generation- Introduction to slicing softwares: Cura.

### Module 3

Principle, process parameters, advantages and applications of: Fused Deposition Modelling (FDM), Selective Laser Sintering (SLS), Stereo Lithography (SLA). Laminated Object Manufacturing (LOM), Electron Beam Melting (EBM), Laser Engineering Net Shaping (LENS),

### Module 4

Principle, process parameters, advantages and applications of: Selection Laser Melting (SLM), Jetting, 3D Printing-STL Format, STL File Problems, consequence of building valid and invalid tessellated models, STL file Repairs: Generic Solution, other Translators, Newly Proposed Formats.

### Module 5

Direct processes: - Rapid Prototyping, Rapid Tooling. Rapid Manufacturing; Indirect Processes: - Indirect Prototyping. Indirect Tooling, Indirect Manufacturing. Applications and case studies of Additive Manufacturing: –Biomedical- Manufacturing- Aerospace-Automotive- Food- Electronics.

### Text Books

1. Gibson, I, Rosen, D W., and Stucker,B., Additive Manufacturing Methodologies: Rapid Prototyping to Direct Digital Manufacturing, Springer, 2010
2. Chua C.K., Leong K.F., and Lim C.S., “Rapid prototyping: Principles and applications”, Third Edition, World Scientific Publishers, 2010
3. Chee Kai Chua, Kah Fai Leong, 3D Printing and Additive Manufacturing: Principles and Applications: Fourth Edition of Rapid Prototyping, World Scientific Publishers, 2014
4. Gebhardt A., “Rapid prototyping”, Hanser Gardener Publications, 2003

### Reference Books

1. Liou L.W. and Liou F.W., “Rapid Prototyping and Engineering applications: A tool box for prototype development”, CRC Press, 2007
2. Kamrani A.K. and Nasr E.A., “Rapid Prototyping: Theory and practice”, Springer, 2006
3. Mahamood R.M., Laser Metal Deposition Process of Metals, Alloys, and Composite Materials, Engineering Materials and Processes, Springer International Publishing AG 2018

4. Ehsan Toyserkani, Amir Khajepour, Stephen F. Corbin, "Laser Cladding", CRC Press, 2004
5. Christopher Barnatt, "3D Printing", Explaining The Future.com, 2014.
6. Paul F Jacobs, "Stereolithography and other RP&M Technologies: from Rapid Prototyping to Rapid Tooling", Society of Manufacturing Engineers and the Rapid Prototyping Association, New York, 1996.

#### Course Contents and Lecture Schedule

No	Topic	No. of Lectures
MODULE 1		
1.1	Introduction to Additive manufacturing: Importance of Additive Manufacturing	2
1.2	Basic principle of additive manufacturing- Procedure of product development in additive manufacturing.	2
1.3	Classification of additive manufacturing processes, Materials used in additive manufacturing	2
1.4	Benefits & Challenges in Additive Manufacturing.	1
MODULE 2		
2.1	Basic Concept — Digitization techniques — Model Reconstruction	1
2.2	Data Processing for Additive Manufacturing Technology:	1
2.3	CAD model preparation — Part Orientation and support generation	1
2.4	Model Slicing — Tool path Generation	1
2.5	Introduction to slicing softwares: Cura.	2
MODULE 3		
3.1	Principle, process, advantages and applications of: Fused Deposition Modelling(FDM),	1
3.2	Principle, process, advantages and applications of: Selective Laser Sintering(SLS), Stereo Lithography(SLA),	2
3.3	Principle, process, advantages and applications of: Laser Engineering Net Shaping (LENS)	2
3.4	Principle, process, advantages and applications of: Laminated Object Manufacturing (LOM), Electron Beam Melting (EBM).	2
MODULE 4		
4.1	Principle, process, advantages and applications of: Selection Laser Melting (SLM), Jetting, 3D Printing	2
4.2	Principle, process, advantages and applications of 3D Printing	2
4.3	STL Format, STL File Problems, consequence of building valid and invalid tessellated models,	2
4.4	STL file Repairs: Generic Solution, other Translators, Newly Proposed Formats.	1
MODULE 5		
5.1	Direct processes: - Rapid Prototyping, Rapid Tooling. Rapid	2



	Manufacturing	
5.2	Indirect Processes: - Indirect Prototyping. Indirect Tooling, Indirect Manufacturing.	2
5.3	Applications and case studies of Additive Manufacturing: –Biomedical- Manufacturing-	2
5.4	Applications and case studies of Additive Manufacturing: –Aerospace- Automotive- Food- Electronics.	2

COURSE CODE	COURSE NAME	CATEGORY	L	T	P	CREDITS
22MEE804.7	POWER PLANT ENGINEERING	PROGRAM ELECTIVE V	2	1	0	3

Preamble: Power Plant Engineering basically focuses on power generation principles for real world applications. This course is focused on application of energy principles and power generation cycles. The main purpose of implementing this course in curriculum is to learn about how the power is generated in a power plant and its applications

Prerequisite: MET205 THERMODYNAMICS, MET303 THERMAL ENGINEERING

Course Outcomes: After the completion of the course the student will be able to

CO 1	Explain the layout, construction and working of the components inside a thermal power plant
CO 2	Explain the layout, construction and working of the components inside a Diesel, Gas and Combined cycle power plants.
CO 3	Explain the layout, construction and working of the components inside nuclear power plants.
CO 4	Explain the layout, construction and working of the components inside Renewable energy power plants.
CO 5	Identify applications of power plants, plant economics, environmental hazards and estimate the costs of electrical energy production.

Mapping of course outcomes with program outcomes

	PO 1	PO 2	PO 3	PO 4	PO 5	PO 6	PO 7	PO 8	PO 9	PO 10	PO 11	PO 12
CO 1	2	2	2									
CO 2	2	2	2									
CO 3	2	2	2									
CO 4	2	2	2									
CO 5	2	2	2									

Assessment Pattern

Bloom's Category	Continuous Assessment Tests		End Semester Examination
	1	2	
Remember	10	10	20
Understand	30	30	60
Apply	10	10	20
Analyse			
Evaluate			
Create			

### Mark distribution

Total Marks	CIE	ESE	ESE Duration
150	50	100	3 hours

### Continuous Internal Evaluation Pattern:

Attendance	: 10 marks
Continuous Assessment Test (2 numbers)	: 25 marks
Assignment/Quiz/Course project	: 15 marks

End Semester Examination Pattern: There will be two parts; Part A and Part B. Part A contain 10 questions with 2 questions from each module, having 3 marks for each question. Students should answer all questions. Part B contains 2 questions from each module of which student should answer any one. Each question can have maximum 2 sub-divisions and carry 14 marks.

### Course Level Assessment Questions

#### Course Outcome 1 (CO1):

1. Comment on the methods used for handling of coal.
2. State the advantages and disadvantages of pulverized coal firing.
3. Illustrate and explain the functions of cooling tower.

#### Course Outcome 2 (CO2)

1. State the applications of diesel electric power plants.
2. List the components present in the diesel electric power plants.
3. Illustrate and explain working of a regenerative gas turbine and re-heater with a help of a Pv diagram.

#### Course Outcome 3(CO3):

1. List down the basic factors to be considered for the design of a nuclear power reactor
2. Give example for the components of pressurized water reactor nuclear power plan.
3. Describe the functionality of moderator.

#### Course Outcome 4 (CO4):

1. Enumerate the advantages and disadvantages of hydropower plants.
2. Comment on different types of ocean thermal energy conversion system.

3. Explain in detail about the various types of Wind energy system.

Course Outcome 5 (CO5):

1. Illustrate and explain the load duration curve.
2. A power station has two 60MW units each running for 1500 hours a year. The energy produced per year is  $700 \times 10^6$  kW-hr. Calculate the plant load factor and plant use factor.
3. Define depreciation and elaborate its role in operation of a power plant.

Model Question Paper

EIGHTH SEMESTER B.TECH DEGREE

EXAMINATION Course Code: MET478

Course Name: POWER PLANT ENGINEERING

Max. Marks: 100

Duration: 3 Hours

PART – A

(ANSWER ALL QUESTIONS, EACH QUESTION CARRIES 3 MARKS)

1. Define drift? How drift is eliminated in cooling towers?
2. Comment on the types of burner employed for pulverized coals in the thermal power plants.
3. What are the methods of cooling in a diesel engine power plant?
4. List out the difference between open cycle and closed cycle gas turbine plant.
5. Mention the advantages of nuclear power plant.
6. Define “half-life” of nuclear fuels.
7. Comment on the working of a solar cell.
8. What are the advantages and limitations of tidal power plant?
9. Define the importance of capital cost in a power plant.
10. Define load factor and list out methods for improvement in load factor.

PART – B

(ANSWER ONE FULL QUESTION FROM EACH MODULE)

MODULE – 1

11. a) Explain the analysis of pollution from thermal power plants. (7 marks)

b) How ash is handled in the power plant? Explain the ash handling system. (7 marks)

OR

12. a) Explain the principle involved in preparation of coal and what are the methods of preparation? (7 marks)

b) Illustrate and explain the working different types of cooling towers. (7 marks)

#### MODULE – 2

13. a) Give the layout of diesel engine power plant. What are the advantages and disadvantages of diesel power plants? (7 marks)

b) List out the difference between the closed cycle and open cycle gas turbine power plants (7 marks)

OR

14. a) Illustrate and explain working of a regenerative gas turbine and re-heater with help of a P-v diagram (7 marks)

b) What are the methods used for improving the efficiency of a gas turbine plant? (7 marks)

#### MODULE – 3

15. a) Explain with neat sketches and with examples difference between controlled and uncontrolled chain reaction? (7 marks)

b) Describe the boiling water reactor with the help of neat sketch and explain its chief characteristics (7 marks)

OR

16. a) Explain the working of a typical fast breeder nuclear reactor power plant, with the help of neat diagram (7 marks)

b) Define commonly used methods of nuclear waste disposal and discuss their salient features. (7 marks)

#### MODULE – 4

17. a) Explain the factors to be considered while selecting the site of a hydro power plant? (7 marks)

b) Explain the construction and working of Geo thermal power plant (7 marks)

OR

18. a) Explain with a neat diagram of wind electric generating power plant. (7 marks)
- b) Explain in detail about the various types of Wind energy system. (7 marks)

MODULE – 5

19. A central power station has annual factors as follows: Load factor = 60%, Capacity factor = 40%, Use factor = 45%, Power station has a maximum demand of 15,000 kW. Determine: Annual energy production, Reserve capacity over and above peak load, Hours per year not in service. (14 marks)

OR

20. a) What are the elements which contribute to the cost of the electricity? How can the cost power generation be reduced? (7 marks)
- b) Define power plant economics? Explain the fixed and operating cost of a power station (7 marks)

## Syllabus

### Module 1

#### COAL BASED THERMAL POWER PLANTS

Rankine cycle – improvisations, Layout of modern coal power plant, Super Critical Boilers, FBC Boilers, Turbines, Condensers, Steam & Heat rate, Subsystems of thermal power plants – Fuel and ash handling, Draught system, Feed water treatment. Binary Cycles and Cogeneration systems.

### Module 2

#### DIESEL, GAS TURBINE AND COMBINED CYCLE POWER PLANTS

Otto, Diesel, Dual & Brayton Cycle – Analysis & Optimisation. Components of Diesel and Gas Turbine power plants. Combined Cycle Power Plants. Integrated Gasifier based Combined Cycle systems.

### Module 3

#### NUCLEAR POWER PLANTS

Basics of Nuclear Engineering, Layout and subsystems of Nuclear Power Plants, Working of Nuclear Reactors : Boiling Water Reactor (BWR), Pressurized Water Reactor (PWR), CANada Deuterium- Uranium reactor (CANDU), Breeder, Gas Cooled and Liquid Metal Cooled Reactors. Safety measures for Nuclear Power plants.

### Module 4

#### POWER FROM RENEWABLE ENERGY

Hydro Electric Power Plants – Classification, Typical Layout and associated components including Turbines. Principle, Construction and working of Wind, Tidal, Solar Photo Voltaic (SPV), Solar Thermal, Geo Thermal, Biogas and Fuel Cell power systems.

### Module 5

#### ENERGY, ECONOMIC AND ENVIRONMENTAL ISSUES OF POWER PLANTS

Power tariff types, Load distribution parameters, load curve, Comparison of site selection criteria, relative merits & demerits, Capital & Operating Cost of different power plants. Pollution control technologies including Waste Disposal Options for Coal and Nuclear Power Plants.

#### Text Books

1. P.C.Sharma, “Power Plant Engineering”, S.K.Kataria Publication, 3<sup>rd</sup> Edition, 2015.
2. Arora and S. Domkundwar , “A Course in Power Plant Engineering”, Dhanpat rai & Co Publication, 5<sup>th</sup> Edition, 2016.
3. P.K. Nag, “Power Plant Engineering”, TMH Publication, 4<sup>th</sup> Edition, 2017.

## Reference Books

1. R.K. Rajput, “A Text Book of Power Plant Engineering”, Laxmi Publications, 5<sup>th</sup> Edition, 2016.
2. K. K. Ramalingam, “Power plant Engineering”, Scitech Publishers, 2<sup>nd</sup> Edition, 2015
3. G.D. Rai, “An Introduction to Power Plant Technology”, Khanna Publishers, 3<sup>rd</sup> Edition, 2011.
4. C. Elanchezhian , “Power Plant Engineering” , I.K. International Publications, 2<sup>nd</sup> Edition, 2013.

## Course Contents and Lecture Schedule

No	Topic	No. of Lectures
1	<b>COAL BASED THERMAL POWER PLANTS</b>	
1.1	Rankine cycle – improvisations	1
1.2	Layout of modern coal power plant, Super Critical Boilers, FBC Boilers	2
1.3	Turbines, Condensers, Steam & Heat rate, Subsystems of thermal power plants.	2
1.4	Fuel and ash handling, Draught system.	2
1.5	Feed water treatment. Binary Cycles and Cogeneration systems	1
2	<b>DIESEL, GAS TURBINE AND COMBINED CYCLE POWER PLANTS</b>	
2.1	Otto, Diesel, Dual & Brayton Cycle – Analysis & Optimisation.	2
2.2	Components of Diesel and Gas Turbine power plants.	2
2.3	Combined Cycle Power Plants.	2
2.4	Integrated Gasifier based Combined Cycle systems.	2
3	<b>NUCLEAR POWER PLANTS</b>	
3.1	Basics of Nuclear Engineering, Layout and subsystems of Nuclear Power Plants, Working of Nuclear Reactors	2
3.2	Boiling Water Reactor (BWR), Pressurized Water Reactor (PWR), CANada Deuterium- Uranium reactor (CANDU),	2
3.3	Breeder, Gas Cooled and Liquid Metal Cooled Reactors.	2
3.4	Safety measures for Nuclear Power plants.	2
4	<b>POWER FROM RENEWABLE ENERGY</b>	
4.1	Hydro Electric Power Plants – Classification, Typical Layout and associated components including Turbines.	2
4.2	Principle, Construction and working of Wind, Tidal, Solar Photo Voltaic (SPV), Solar Thermal, Geo Thermal, Biogas and Fuel Cell power systems.	4
5	<b>ENERGY, ECONOMIC AND ENVIRONMENTAL ISSUES OF POWER PLANTS</b>	
5.1	Power tariff types, Load distribution parameters, load curve, Comparison of site selection criteria, relative merits & demerits,	2
5.2	Capital & Operating Cost of different power plants.	2
5.3	Pollution control technologies	2



---

SEMESTER VIII

---

MINOR

---

COURSE CODE	COURSE NAME	CATEGORY	L	T	P	CREDITS
22MEMR807	MINI PROJECT	P	3	1	0	4

Preamble: Mini Project Phase I: A Project topic must be selected either from research literature or the students themselves may propose suitable topics in consultation with their guides. The object of Project Work I is to enable the student to take up investigative study in the broad field of Mechanical Engineering, either fully theoretical/practical or involving both theoretical and practical work to be assigned by the Department on a group of three/four students, under the guidance of a Supervisor. This is expected to provide a good initiation for the student(s) in R&D work. The assignment to normally include:

- ◆ Survey and study of published literature on the assigned topic;
- ◆ Preparing an Action Plan for conducting the investigation, including team work;
- ◆ Working out a preliminary Approach to the Problem relating to the assigned topic;
- ◆ Block level design documentation
- ◆ Conducting preliminary Analysis/ Modelling/ Simulation/ Experiment/ Design/ Feasibility;
- ◆ Preparing a Written Report on the Study conducted for presentation to the Department;

CO1	Identify and synthesize problems and propose solutions to them.
CO2	Prepare work plan and liaison with the team in completing as per schedule.
CO3	Validate the above solutions by theoretical calculations and through experimental
CO4	Write technical reports and develop proper communication skills.
CO5	Present the data and defend ideas.

Mapping of course outcomes with program outcomes

	PO1	PO2	PO3	PO4	PO5	PO6	PO7	PO8	PO9	PO10	PO11	PO12
CO1	3	3	3	3					3	3		2
CO2	3			3				3	3	3	3	
CO3	3	3	3	3	3					3		
CO4					3			3	3	3		1
CO5	3	3	3	3				3		3	3	1

\*1-slight/low mapping, 2- moderate/medium mapping, 3-substantial/high mapping

## Assessment Pattern

The End Semester Evaluation (ESE) will be conducted as an internal evaluation based on the product, the report and a viva- voce examination, conducted by a 3-member committee appointed by Head of the Department comprising HoD or a senior faculty member, academic coordinator for that program and project guide/coordinator. The Committee will be evaluating the level of completion and demonstration of functionality/specifications, presentation, oral examination, working knowledge and involvement.

The Continuous Internal Evaluation (CIE) is conducted by evaluating the progress of the mini project through minimum of TWO reviews. At the time of the 1<sup>st</sup> review, students are supposed to propose a new system/design/idea, after completing a thorough literature study of the existing systems under their chosen area. In the 2<sup>nd</sup> review students are expected to highlight the implementation details of the proposed solution. The review committee should assess the extent to which the implementation reflects the proposed design. A well coded, assembled and completely functional product is the expected output at this stage. The final CIE mark is the average of 1<sup>st</sup> and 2<sup>nd</sup> review marks.

A zeroth review may be conducted before the beginning of the project to give a chance for the students to present their area of interest or problem domain or conduct open brain storming sessions for innovative ideas. Zeroth review will not be a part of the CIE evaluation process.

## Marks Distribution

Total Marks	CIE	ESE
150	75	75

### Continuous Internal Evaluation Pattern:

Attendance : 10 marks

Marks awarded by Guide : 15 marks

Project Report : 10 marks

Evaluation by the Committee : 40 Marks

End Semester Examination Pattern: The following guidelines should be followed regarding award of marks.

(a) Demonstration : 50 Marks

(b) Project report : 10 Marks

(d) Viva voce : 15marks

## Course Plan

In this course, each group consisting of three/four members is expected to design and develop a moderately complex software/hardware system with practical applications. This should be a working model. The basic concept of product design may be taken into consideration.

Students should identify a topic of interest in consultation with Faculty-in-charge of miniproject/Advisor. Review the literature and gather information pertaining to the chosen topic. State the objectives and develop a methodology to achieve the objectives. Carryout the design/fabrication or develop codes/programs to achieve the objectives. Demonstrate the novelty of the project through the results and outputs. The progress of the mini project is evaluated based on a minimum of two reviews.

The review committee may be constituted by the Head of the Department. A project report is required at the end of the semester. The product has to be demonstrated for its full design specifications. Innovative design concepts, reliability considerations, aesthetics/ergonomic aspects taken care of in the project shall be given due weight.

---

# SEMESTER VIII

---

## HONOURS

---

COURSE CODE	COURSE NAME	CATEGORY	L	T	P	CREDITS
22MEHR808	MINI PROJECT	P	3	1	0	4

Preamble: Mini Project Phase I: A Project topic must be selected either from research literature or the students themselves may propose suitable topics in consultation with their guides. The object of Project Work I is to enable the student to take up investigative study in the broad field of Mechanical Engineering, either fully theoretical/practical or involving both theoretical and practical work to be assigned by the Department on a group of three/four students, under the guidance of a Supervisor. This is expected to provide a good initiation for the student(s) in R&D work. The assignment to normally include:

- ◆ Survey and study of published literature on the assigned topic;
- ◆ Preparing an Action Plan for conducting the investigation, including team work;
- ◆ Working out a preliminary Approach to the Problem relating to the assigned topic;
- ◆ Block level design documentation
- ◆ Conducting preliminary Analysis/ Modelling/ Simulation/ Experiment/ Design/ Feasibility;
- ◆ Preparing a Written Report on the Study conducted for presentation to the Department;

CO1	Identify and synthesize problems and propose solutions to them.
CO2	Prepare work plan and liaison with the team in completing as per schedule.
CO3	Validate the above solutions by theoretical calculations and through experimental
CO4	Write technical reports and develop proper communication skills.
CO5	Present the data and defend ideas.

Mapping of course outcomes with program outcomes

	PO1	PO2	PO3	PO4	PO5	PO6	PO7	PO8	PO9	PO10	PO11	PO12
CO1	3	3	3	3					3	3		2
CO2	3			3				3	3	3	3	
CO3	3	3	3	3	3					3		
CO4					3			3	3	3		1
CO5	3	3	3	3				3		3	3	1

\*1-slight/low mapping, 2- moderate/medium mapping, 3-substantial/high mapping

## Assessment Pattern

The End Semester Evaluation (ESE) will be conducted as an internal evaluation based on the product, the report and a viva- voce examination, conducted by a 3-member committee appointed by Head of the Department comprising HoD or a senior faculty member, academic coordinator for that program and project guide/coordinator. The Committee will be evaluating the level of completion and demonstration of functionality/specifications, presentation, oral examination, working knowledge and involvement.

The Continuous Internal Evaluation (CIE) is conducted by evaluating the progress of the mini project through minimum of TWO reviews. At the time of the 1<sup>st</sup> review, students are supposed to propose a new system/design/idea, after completing a thorough literature study of the existing systems under their chosen area. In the 2<sup>nd</sup> review students are expected to highlight the implementation details of the proposed solution. The review committee should assess the extent to which the implementation reflects the proposed design. A well coded, assembled and completely functional product is the expected output at this stage. The final CIE mark is the average of 1<sup>st</sup> and 2<sup>nd</sup> review marks.

A zeroth review may be conducted before the beginning of the project to give a chance for the students to present their area of interest or problem domain or conduct open brain storming sessions for innovative ideas. Zeroth review will not be a part of the CIE evaluation process.

## Marks Distribution

Total Marks	CIE	ESE
150	75	75

### Continuous Internal Evaluation Pattern:

Attendance : 10 marks  
Marks awarded by Guide : 15 marks  
Project Report : 10 marks  
Evaluation by the Committee : 40 Marks

End Semester Examination Pattern: The following guidelines should be followed regarding award of marks.

- (a) Demonstration : 50 Marks
- (b) Project report : 10 Marks
- (d) Viva voce : 15marks

## Course Plan

In this course, each group consisting of three/four members is expected to design and develop a moderately complex software/hardware system with practical applications. This should be a working model. The basic concept of product design may be taken into consideration.

Students should identify a topic of interest in consultation with Faculty-in-charge of miniproject/Advisor. Review the literature and gather information pertaining to the chosen topic. State the objectives and develop a methodology to achieve the objectives. Carryout the design/fabrication or develop codes/programs to achieve the objectives. Demonstrate the novelty of the project through the results and outputs. The progress of the mini project is evaluated based on a minimum of two reviews.

The review committee may be constituted by the Head of the Department. A project report is required at the end of the semester. The product has to be demonstrated for its full design specifications. Innovative design concepts, reliability considerations, aesthetics/ergonomic aspects taken care of in the project shall be given due weight.